



US00D635108S

(12) **United States Design Patent**
Hughes et al.

(10) **Patent No.:** **US D635,108 S**
(45) **Date of Patent:** **** Mar. 29, 2011**

(54) **AIRCRAFT SEAT UNIT**
(75) Inventors: **Mitchell Robert Edward Hughes,**
Whangaparaoa (NZ); **Jamie Stewart**
Booth, Auckland (NZ)
(73) Assignee: **Air New Zealand Limited,** Auckland
(NZ)
(**) Term: **14 Years**
(21) Appl. No.: **29/354,868**
(22) Filed: **Jan. 29, 2010**

| | | | | | |
|--------------|-----|---------|--------------|-------|-----------|
| D548,207 | S * | 8/2007 | Hsiung | | D14/129 |
| 7,252,340 | B2 | 8/2007 | Johnson | | |
| D564,991 | S * | 3/2008 | Vitito | | D14/126 |
| D597,980 | S * | 8/2009 | Vitito | | D14/129 |
| 2003/0106469 | A1 | 6/2003 | Jensen | | |
| 2003/0111888 | A1 | 6/2003 | Brennan | | |
| 2004/0007906 | A1* | 1/2004 | Park et al. | | 297/217.3 |
| 2004/0032543 | A1* | 2/2004 | Chang | | 348/837 |
| 2004/0227861 | A1* | 11/2004 | Schedivy | | 348/837 |
| 2006/0148577 | A1* | 7/2006 | Vitito | | 463/46 |
| 2006/0175882 | A1 | 8/2006 | Schweizer | | |
| 2007/0001493 | A1 | 1/2007 | Chang | | |
| 2007/0018494 | A1 | 1/2007 | Gutosky, Jr. | | |
| 2007/0283855 | A1 | 12/2007 | Pozzi | | |

(30) **Foreign Application Priority Data**
Jan. 14, 2010 (NZ) 41 321 7
(51) **LOC (9) Cl.** **14-03**
(52) **U.S. Cl.** **D14/129**
(58) **Field of Classification Search** D14/125-134,
D14/239, 371, 136, 374-377, 440, 450, 448,
D14/336, 342; 312/7.2; 348/836, 838, 180,
348/184, 325, 739; 341/12; 248/917-924,
248/465; 345/104, 133, 156, 168, 87, 173;
720/605, 669, 600, 655; 369/99, 197; 455/344,
455/347; D21/329, 515, 577, 622, 333, 433,
D21/448, 452, 450, 331; D6/477, 479, 300;
273/148 B; 446/484, 175, 356; D10/15,
D10/26
See application file for complete search history.

FOREIGN PATENT DOCUMENTS

| | | |
|----|------------|---------|
| EP | 0346299 | 5/1992 |
| EP | 1260433 | 11/2002 |
| EP | 1683719 | 7/2006 |
| WO | 2005016752 | 2/2005 |

(Continued)

Primary Examiner — Raphael Barkai
(74) *Attorney, Agent, or Firm* — Dann, Dorfman, Herrell
and Skillman, P.C.

(57) **CLAIM**
We claim the ornamental design for an aircraft seat unit, as
shown.

DESCRIPTION

FIG. 1 is a top plan view of an aircraft seat unit embodying the
design;
FIG. 2 is a front view thereof;
FIG. 3 is a left side view thereof;
FIG. 4 is a top rear perspective view thereof;
FIG. 5 is a left rear perspective view thereof;
FIG. 6 is a left front perspective view thereof;
FIG. 7 is a left front perspective view thereof with leg rest
portions of the seat unit in a raised position; and,
FIG. 8 is a close up rear perspective view thereof.
The features shown in broken lines form no part of the design.

1 Claim, 8 Drawing Sheets

(56) **References Cited**

U.S. PATENT DOCUMENTS

| | | | | | |
|-----------|-----|---------|--------------|-------|---------|
| 5,179,447 | A * | 1/1993 | Lain | | 348/837 |
| D469,413 | S * | 1/2003 | To et al. | | D14/126 |
| 6,669,143 | B1 | 12/2003 | Johnson | | |
| 6,899,397 | B2 | 5/2005 | Johnson | | |
| D515,522 | S * | 2/2006 | Vitito | | D14/126 |
| D518,004 | S * | 3/2006 | Peng | | D14/126 |
| 7,111,904 | B2 | 9/2006 | Dowty et al. | | |
| D540,283 | S * | 4/2007 | Tsai | | D14/126 |

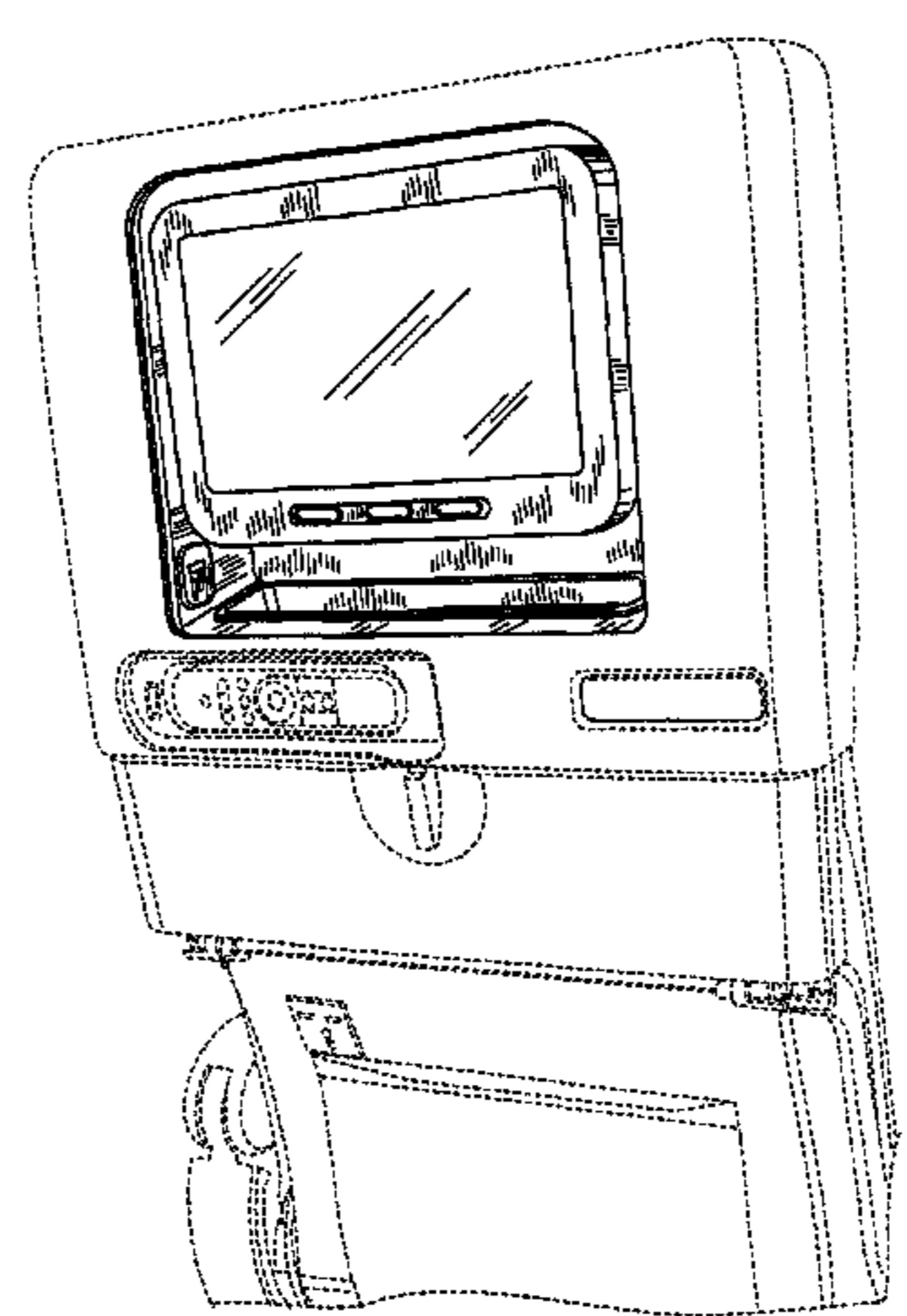

US D635,108 S

Page 2

| FOREIGN PATENT DOCUMENTS | | | | | |
|--------------------------|------------|--------|----|------------|---------|
| WO | 2005058632 | 6/2005 | WO | 2006041417 | 4/2006 |
| WO | 2005058633 | 6/2005 | WO | 2007015832 | 2/2007 |
| WO | 2005060591 | 7/2005 | WO | 2007123615 | 11/2007 |
| WO | 2005060598 | 7/2005 | WO | 2007128978 | 11/2007 |
| WO | 2005060599 | 7/2005 | WO | 2007135373 | 11/2007 |
| WO | 2005073083 | 8/2005 | | | |

* cited by examiner

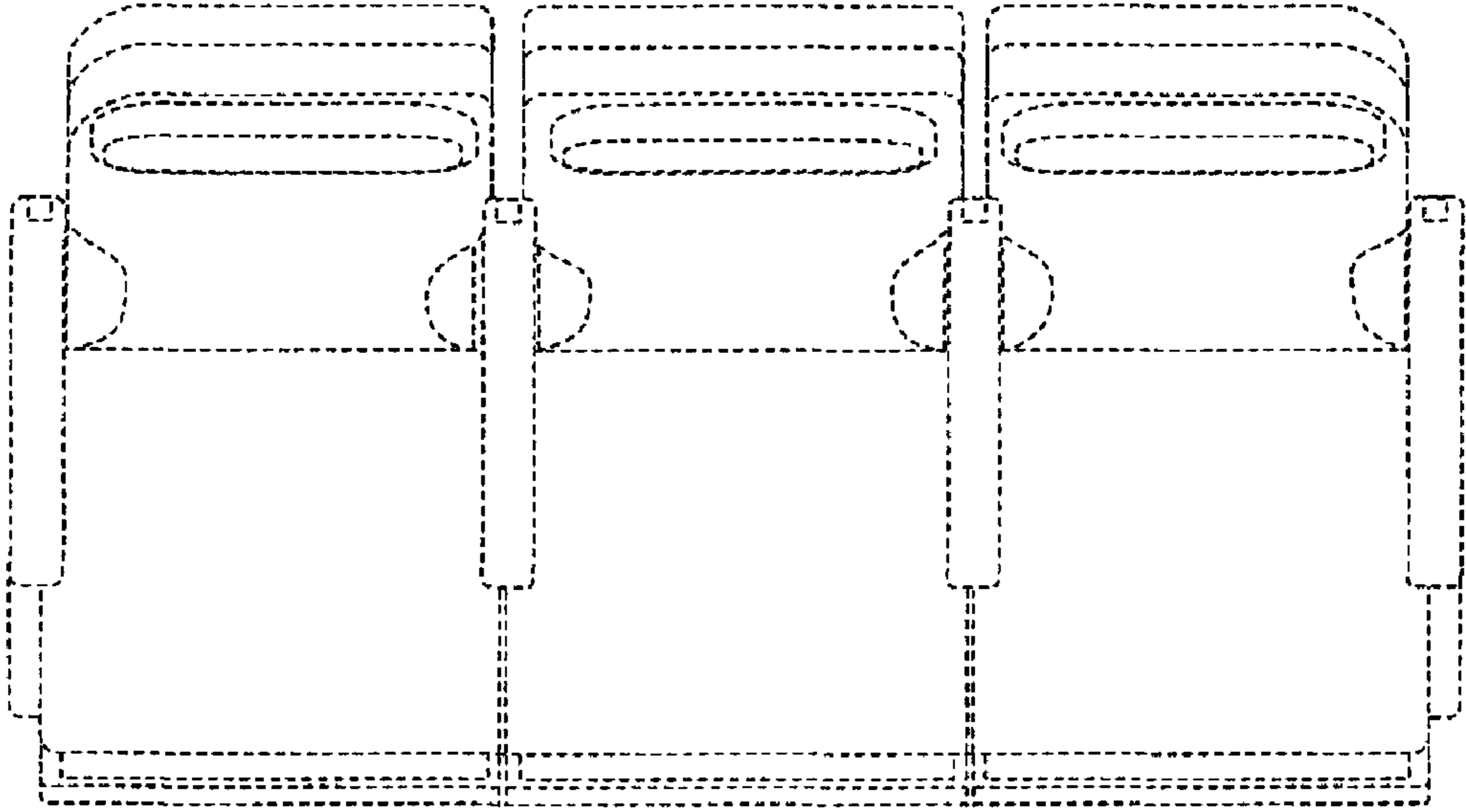

FIG. 1

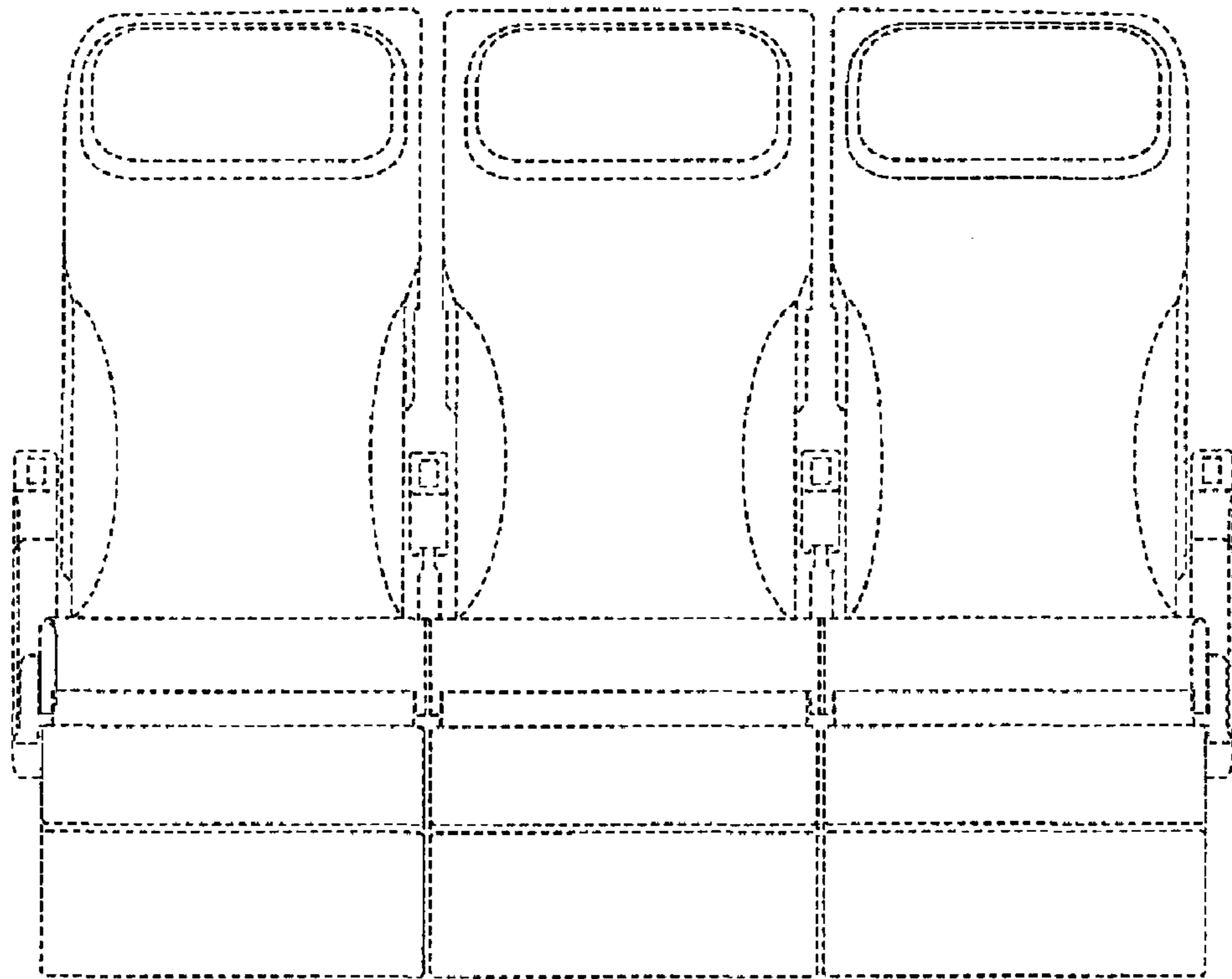

FIG. 2

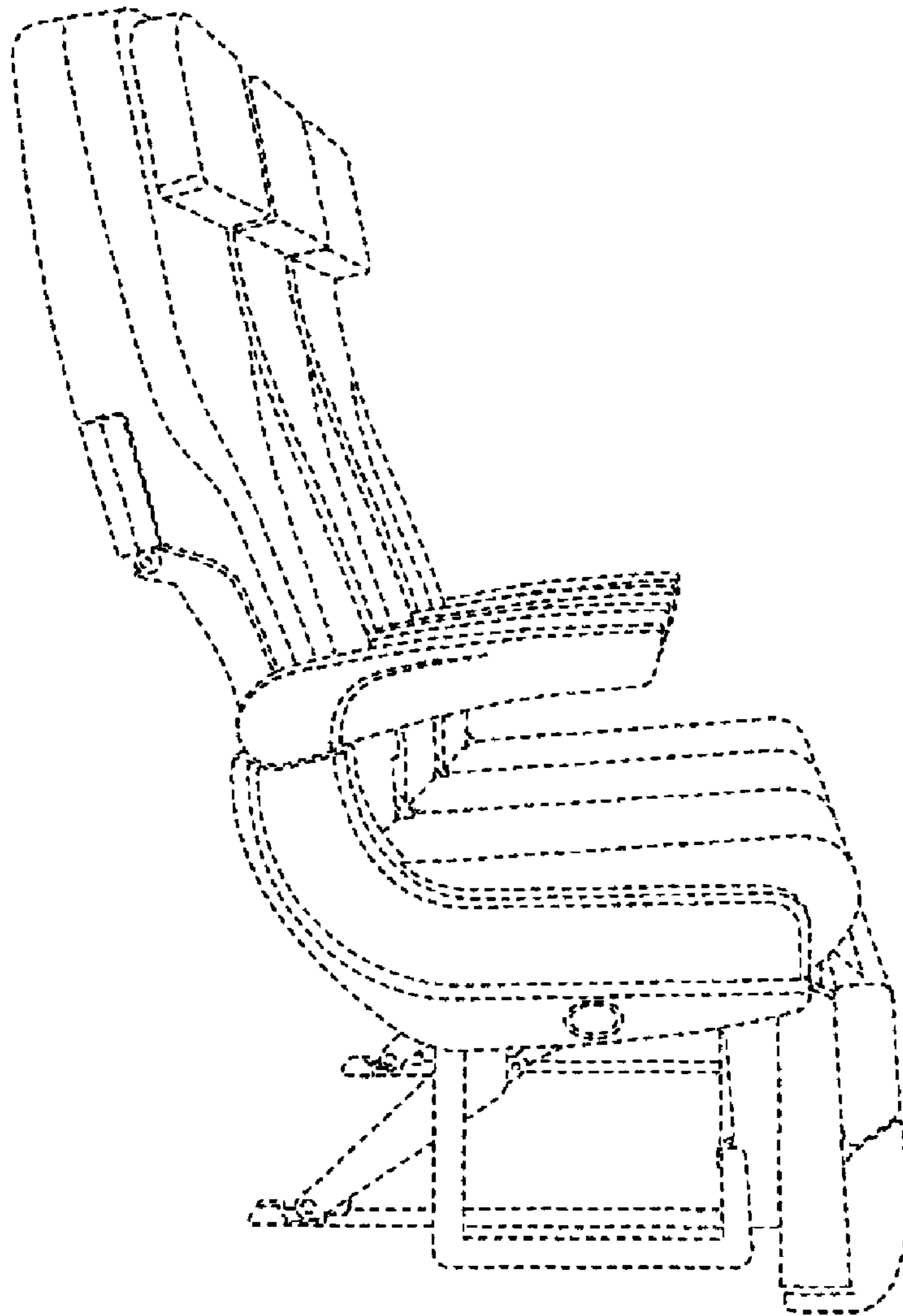

FIG. 3

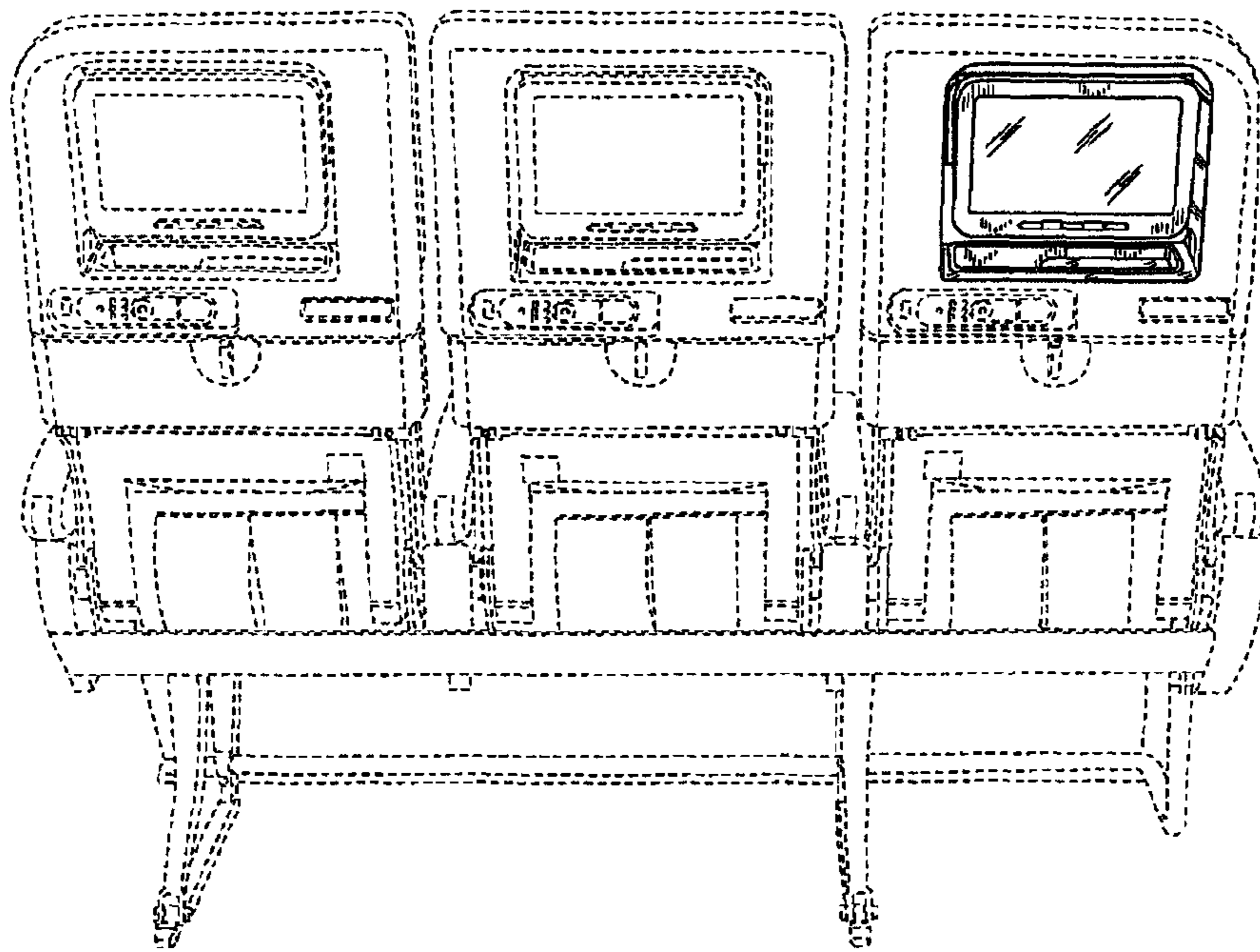

FIG. 4

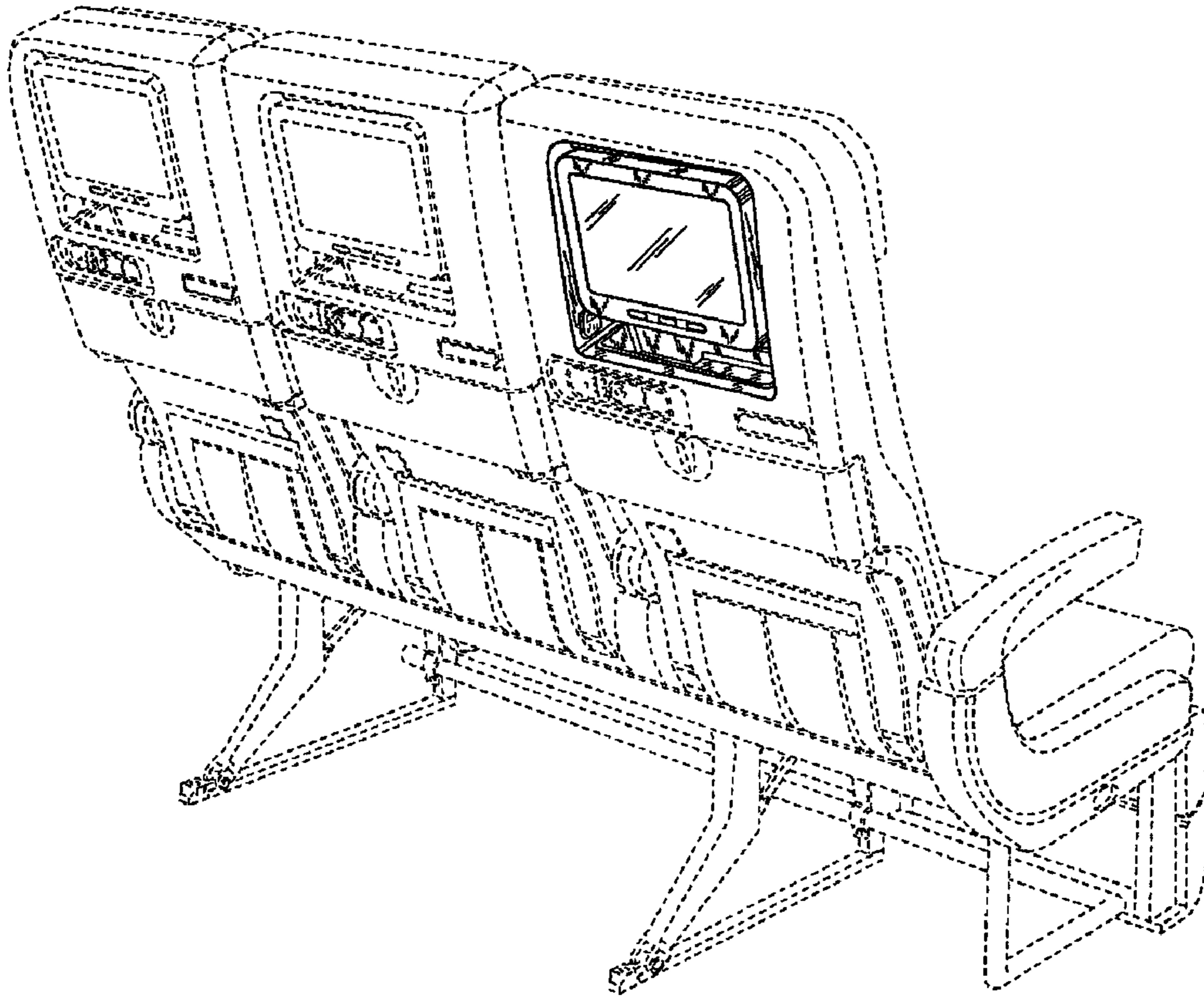

FIG. 5

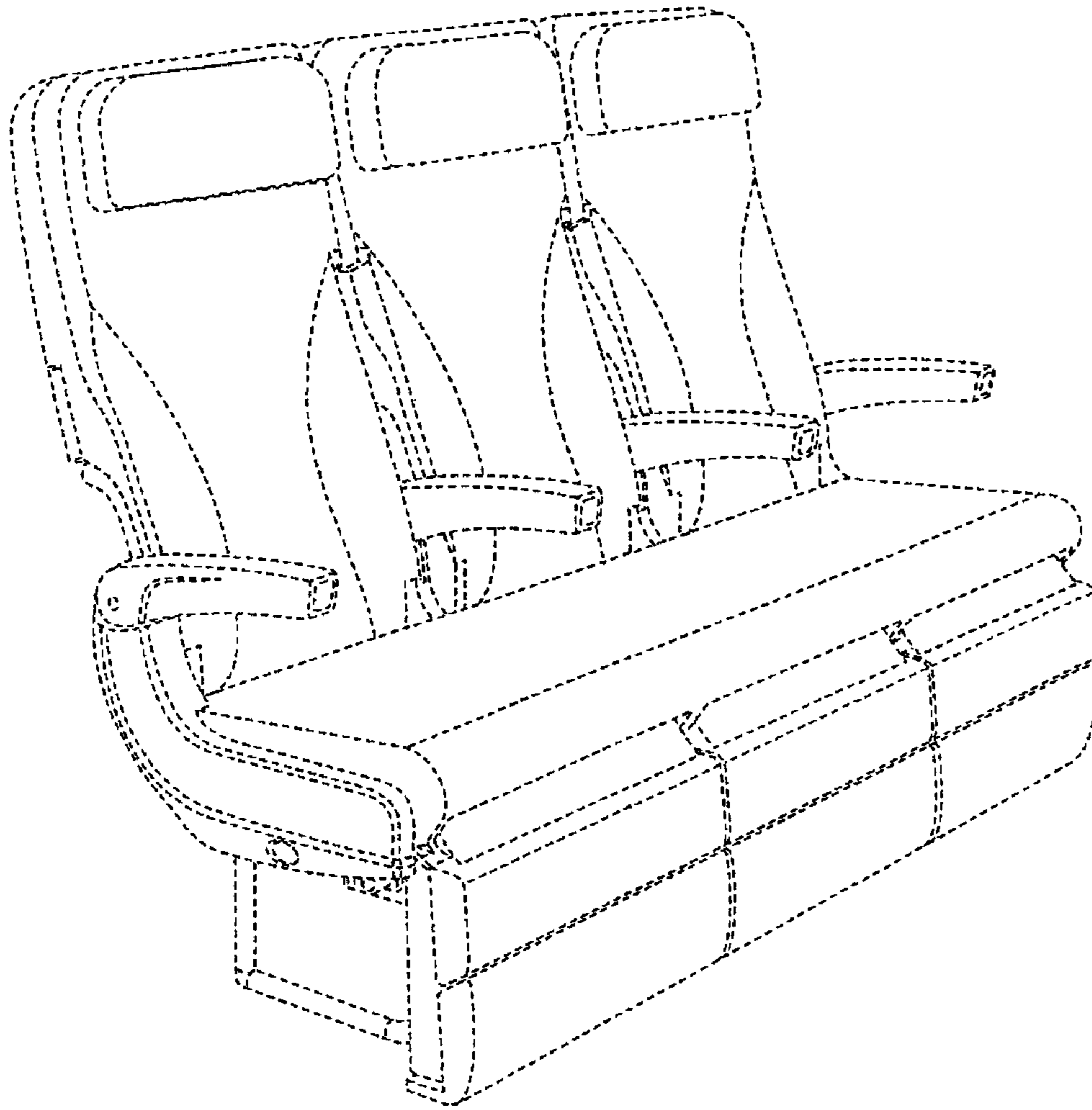

FIG. 6

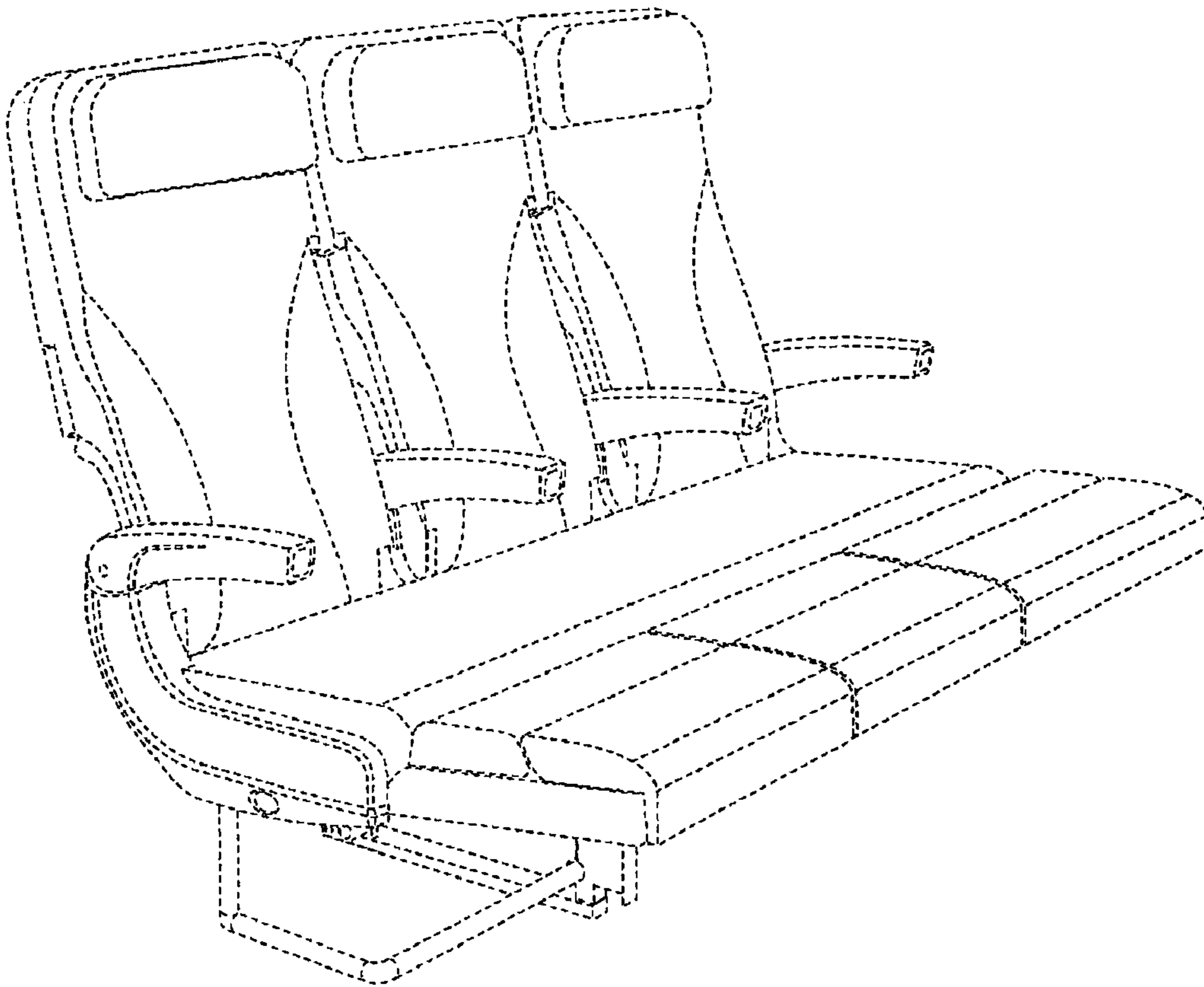

FIG. 7

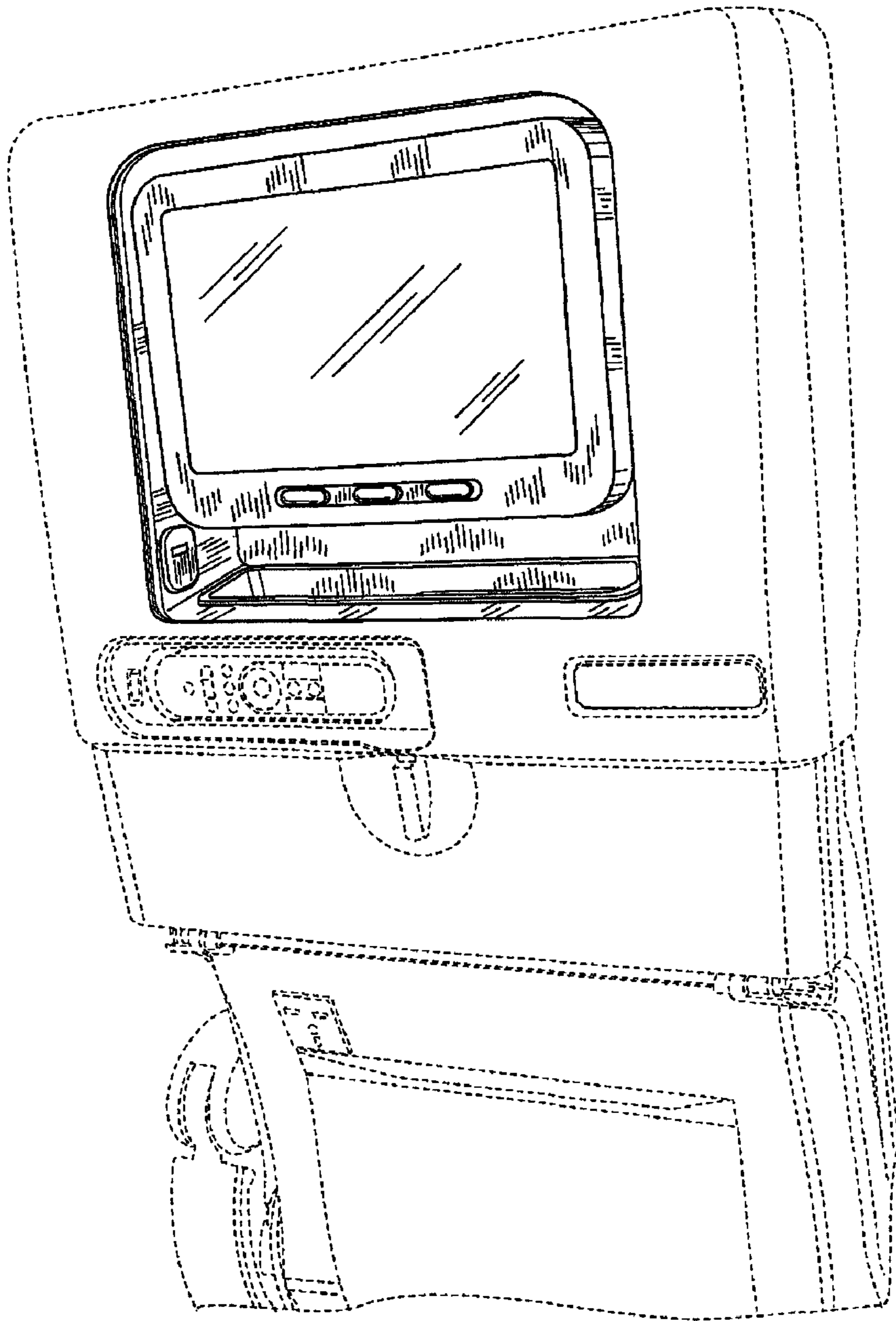

FIG. 8