



US00D635104S

(12) **United States Design Patent**
Louise et al.

(10) **Patent No.:** **US D635,104 S**
(45) **Date of Patent:** **** Mar. 29, 2011**

(54) **BUTTON FOR AN AIRCRAFT CONTROL DEVICE**

(75) Inventors: **Pascale Louise**, Toulouse (FR); **Fabien Silly**, Cugnaux (FR); **Christian Serieyssol**, Pibrac (FR)

(73) Assignee: **Airbus Operations S.A.S.**, Toulouse Cedex (FR)

(**) Term: **14 Years**

(21) Appl. No.: **29/353,382**

(22) Filed: **Jan. 7, 2010**

(51) **LOC (9) Cl.** **13-03**

(52) **U.S. Cl.** **D13/174**

(58) **Field of Classification Search** D13/174;
D8/310, 311, DIG. 2; D23/250-252; D12/192;
16/441; 116/309; 200/11 R, 316, 336; 244/99.2,
244/197, 220, 221, 234; 74/553
See application file for complete search history.

(56) **References Cited**

U.S. PATENT DOCUMENTS

D132,433	S *	5/1942	Pellegrin	D8/311
D141,840	S *	7/1945	Stewart	D8/307
2,420,985	A *	5/1947	Simpson	74/553
2,537,782	A *	1/1951	Meyers	116/309
2,957,447	A *	10/1960	Pearce	116/332
4,584,510	A *	4/1986	Hollow	318/584
D297,726	S *	9/1988	Araki	D13/174
5,359,165	A *	10/1994	Leveque et al.	200/317
5,687,834	A *	11/1997	Simon et al.	200/336
D400,778	S *	11/1998	Holbrook, Jr.	D8/311
D438,846	S *	3/2001	Bonn	D13/174
D450,997	S *	11/2001	Brady	D8/311
D457,416	S *	5/2002	Caspersz	D8/311
6,423,912	B1 *	7/2002	Arenz et al.	200/43.08
6,518,526	B2 *	2/2003	Hamada et al.	200/330
7,222,979	B1 *	5/2007	Popowich et al.	362/26
7,307,232	B2 *	12/2007	Altmann et al.	200/564

D559,206	S *	1/2008	Neveu	D13/174
D564,980	S *	3/2008	Browne et al.	D13/174
D581,298	S *	11/2008	Beaujard et al.	D10/67
D613,698	S *	4/2010	Radau	D13/169
2004/0107545	A1 *	6/2004	Worrell	16/441
2005/0241112	A1 *	11/2005	Worrell	16/433

* cited by examiner

Primary Examiner — Selina Sikder

(74) *Attorney, Agent, or Firm* — Osler, Hoskin & Harcourt LLP

(57) **CLAIM**

The ornamental design for a button for an aircraft control device, as shown and described.

DESCRIPTION

FIG. 1 is a front, right perspective view showing a button for an aircraft control device according to our design; FIG. 2 is a rear, left perspective view thereof; FIG. 3 is a top plan view thereof; FIG. 4 is a bottom plan view thereof; FIG. 5 is a left side elevation view thereof; FIG. 6 is a right side elevation view thereof; FIG. 7 is a front elevation view thereof; FIG. 8 is a rear elevation view thereof; FIG. 9 is a front, left perspective view of the button for an aircraft control device of FIG. 1, shown on an aircraft control device shown in broken lines; and, FIG. 10 is a front, right perspective view of the button for an aircraft control device of FIG. 1, shown with a hand of a user in broken lines interacting with the button. Throughout the Figures, where shown: (i) the dotted lines showing additional structure of the button for an aircraft control device or environment are for illustrative purposes only and form no part of the claimed design; (ii) the unshaded surfaces do not form part of the claimed design; and (iii) the dash-dot lines illustrate unclaimed boundaries of surfaces claimed as part of the design.

1 Claim, 10 Drawing Sheets

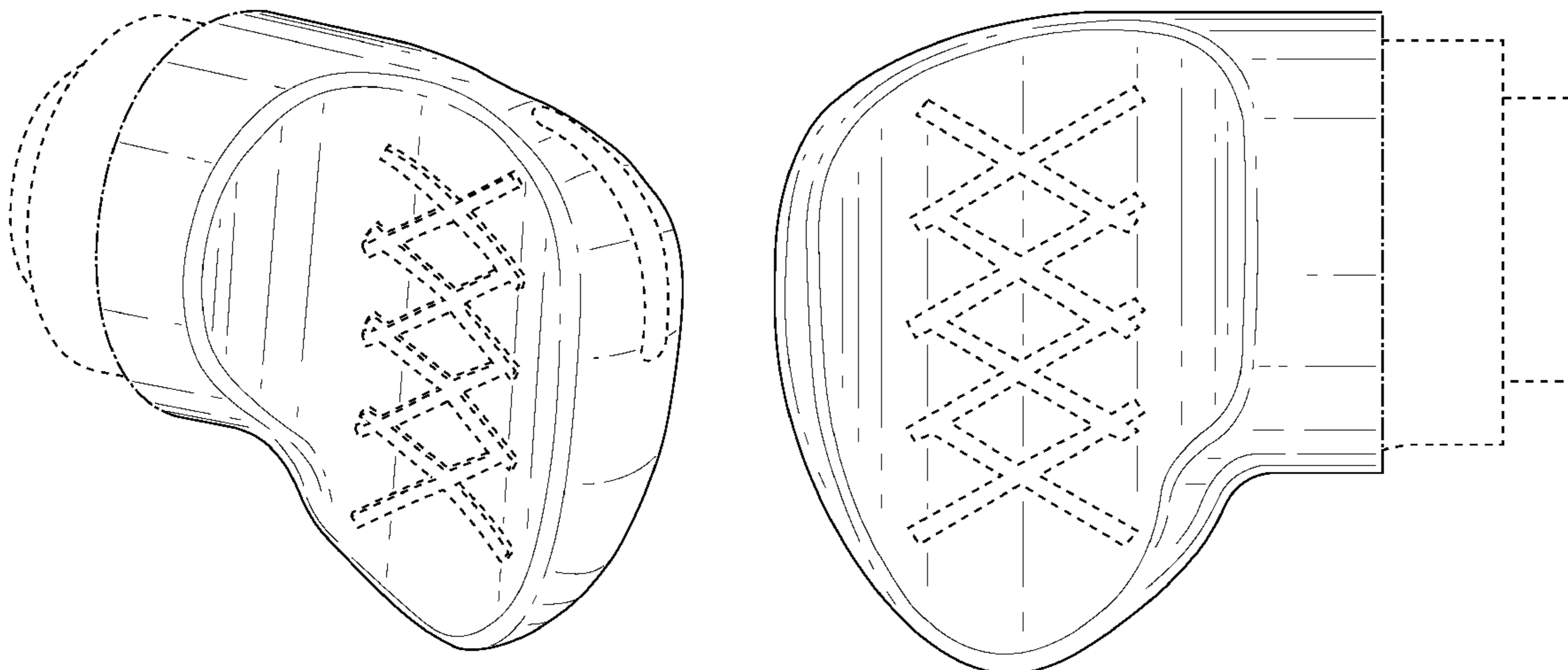

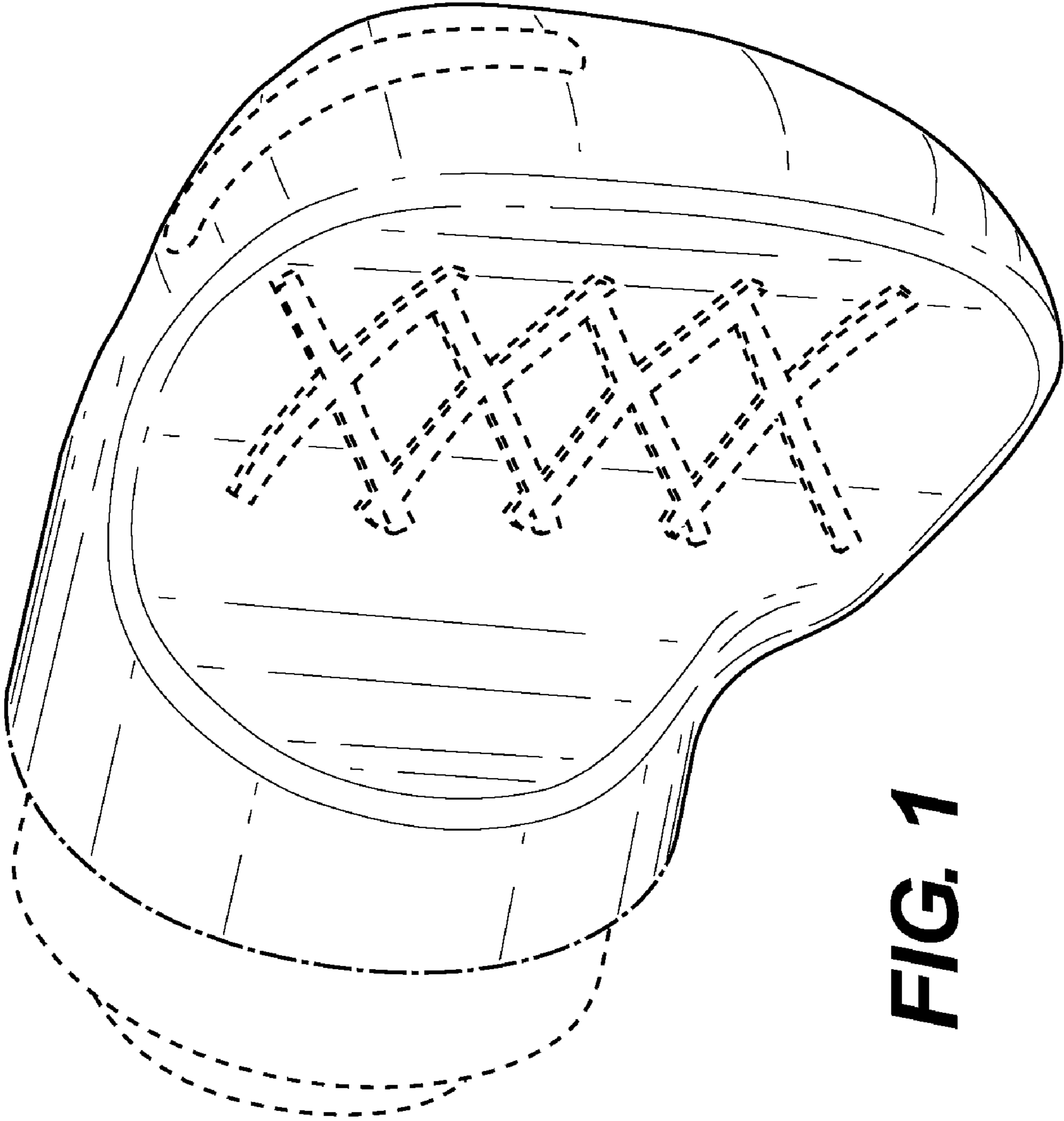

FIG. 1

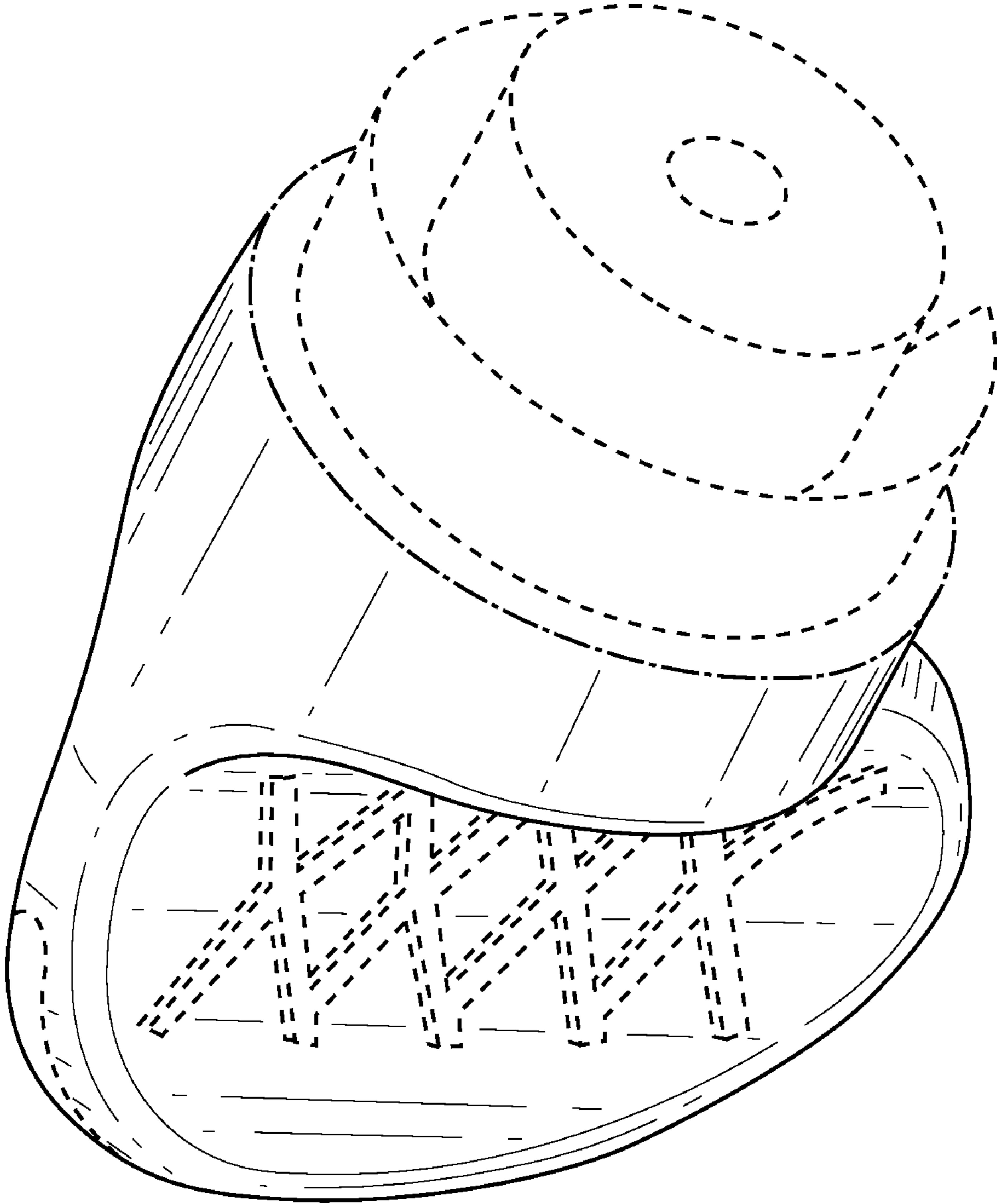

FIG. 2

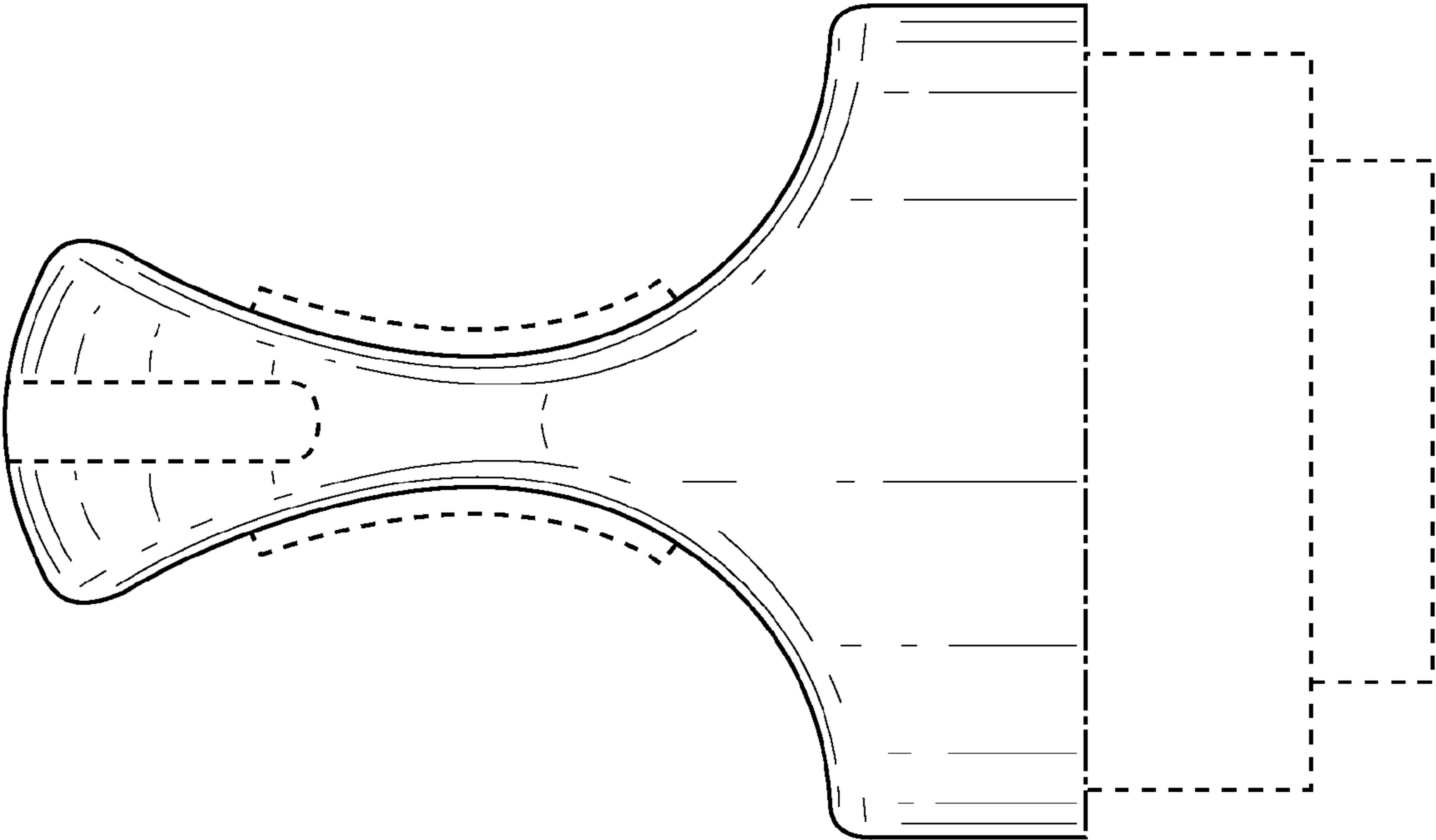

FIG. 3

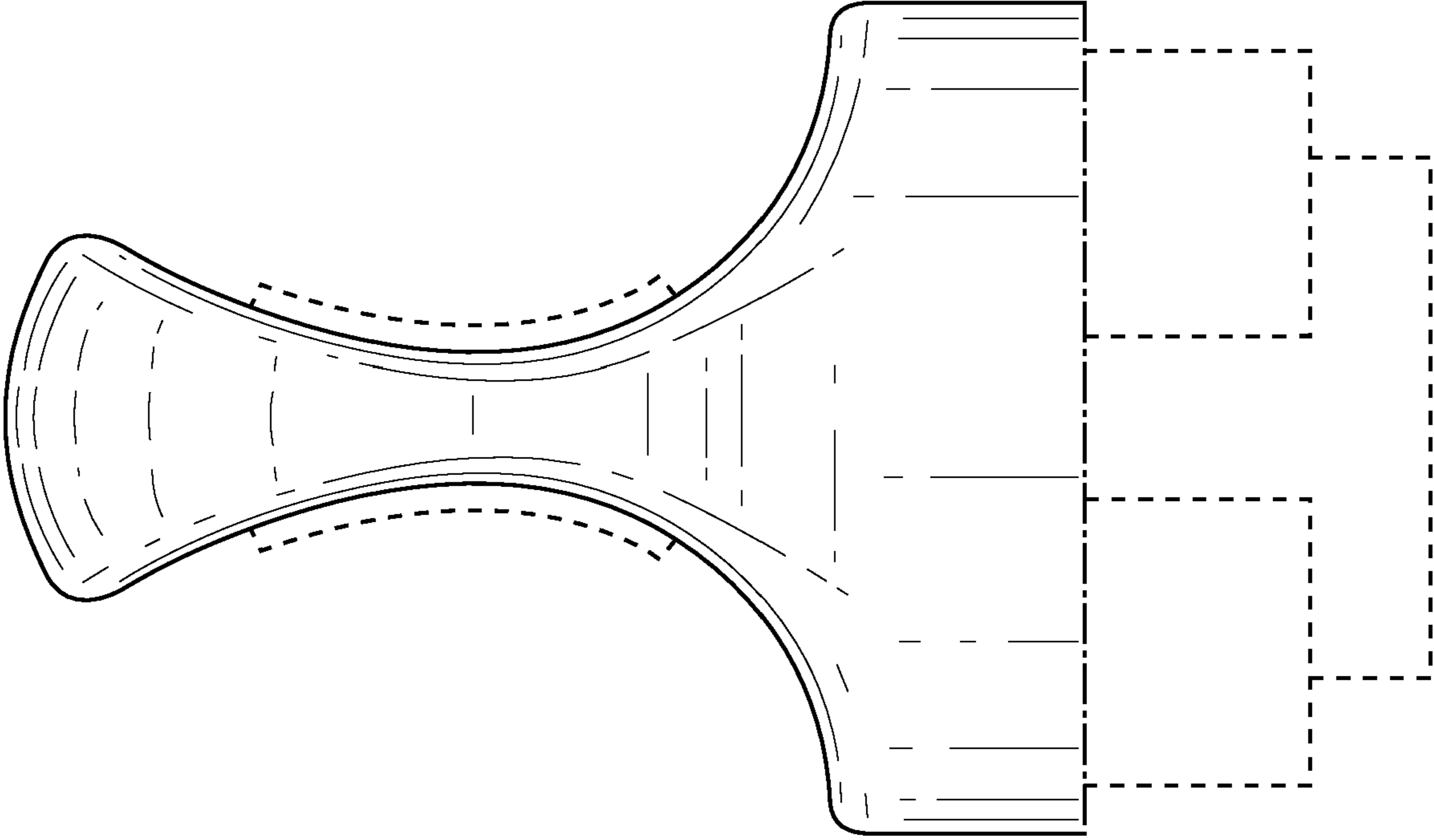

FIG. 4

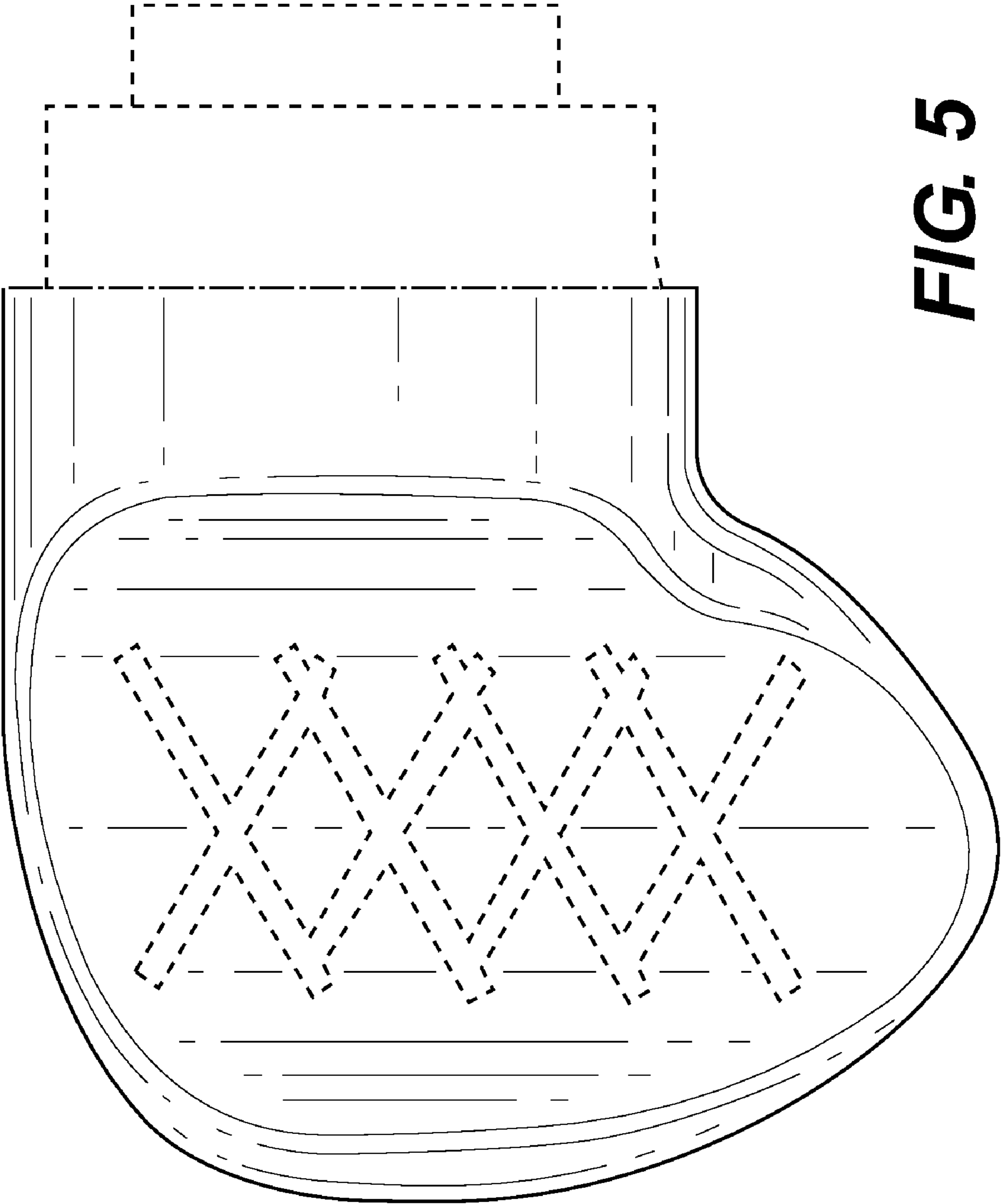

FIG. 5

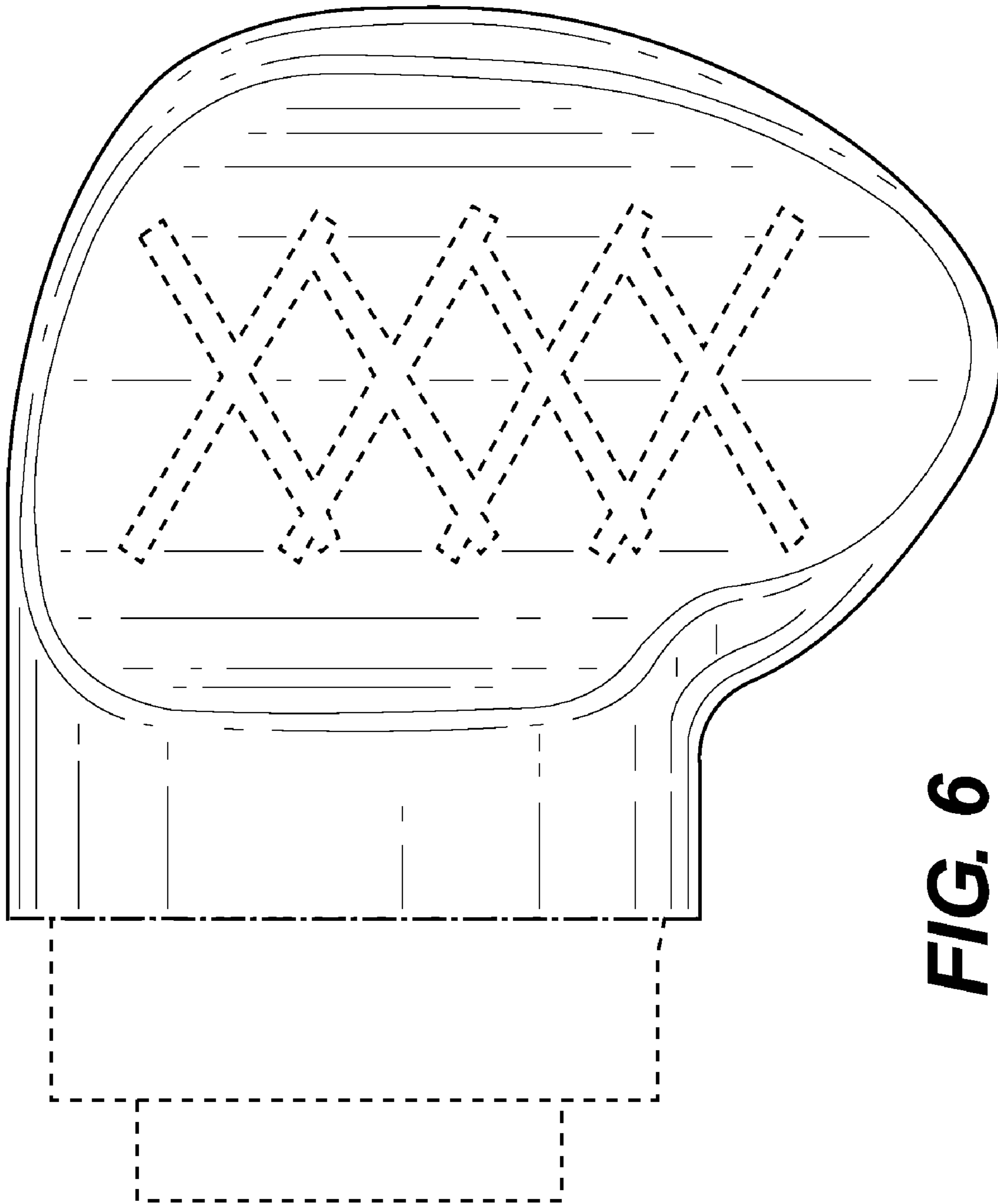

FIG. 6

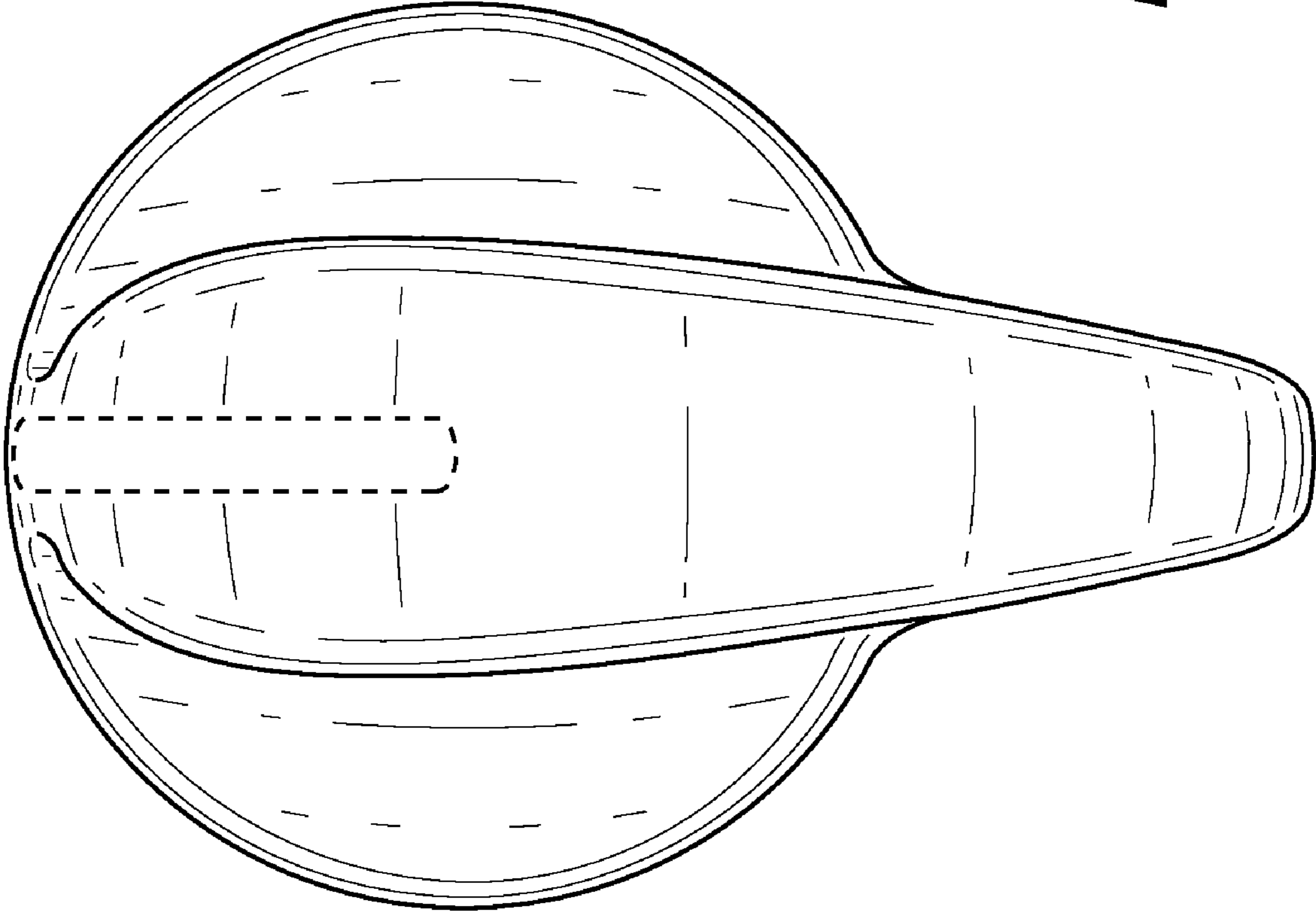

FIG. 7

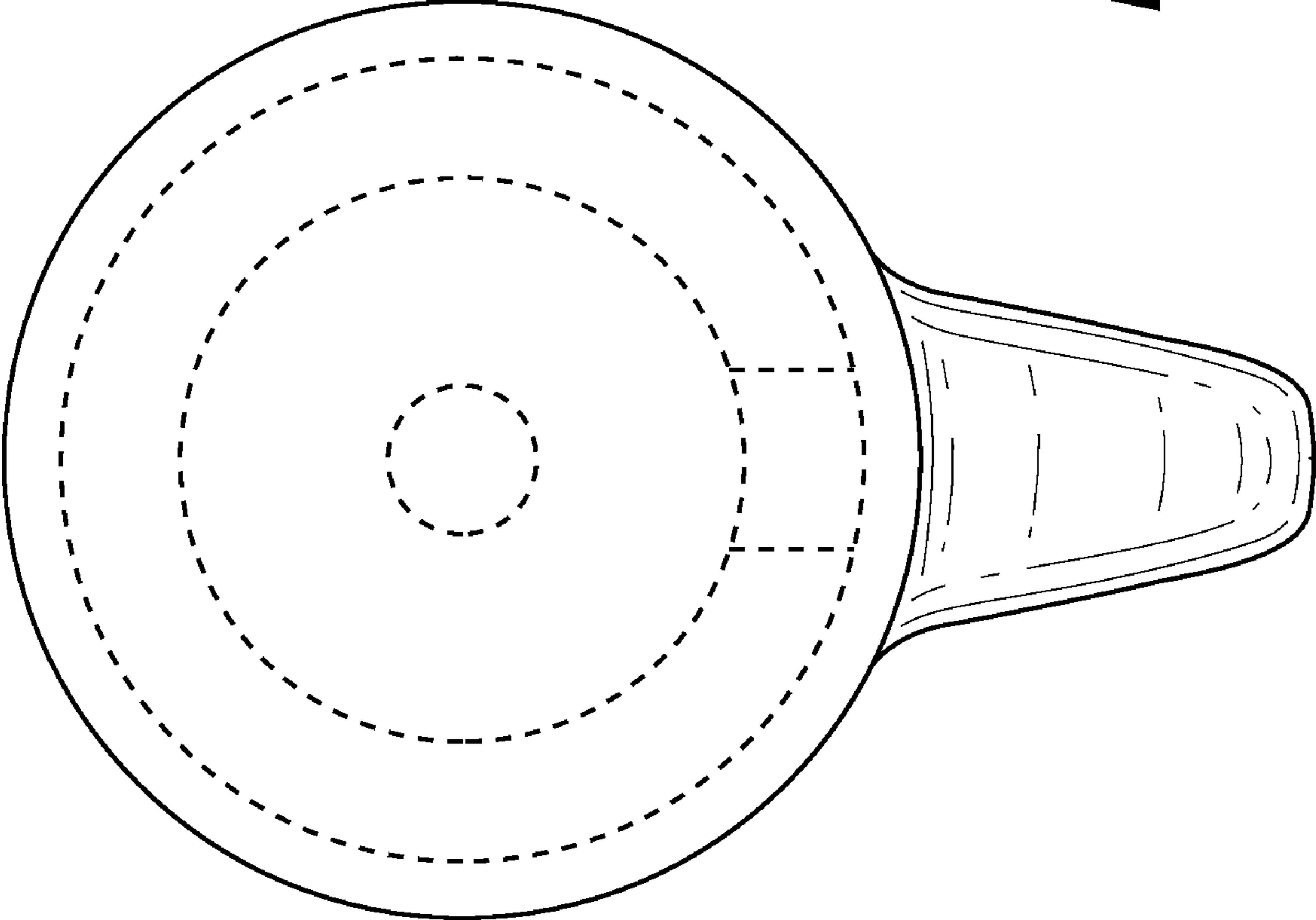

FIG. 8

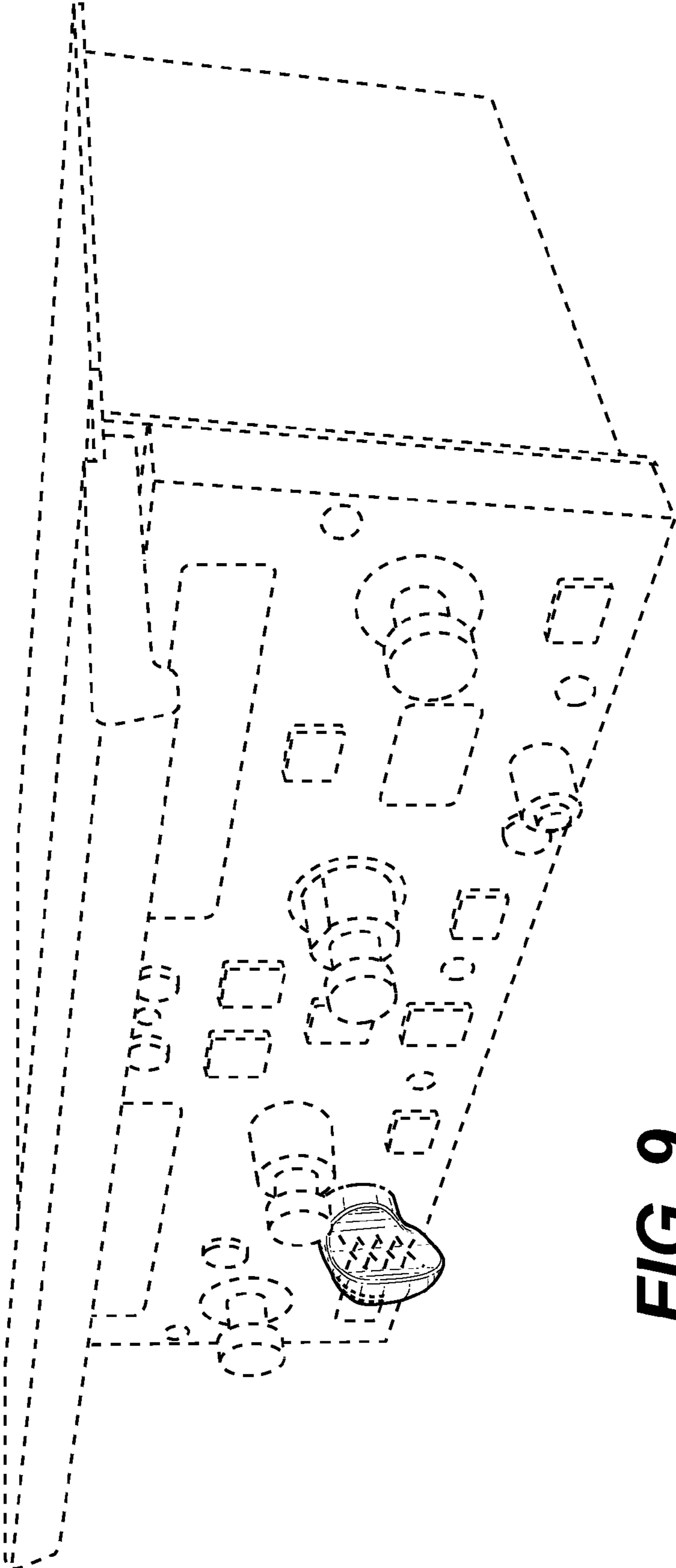

FIG. 9

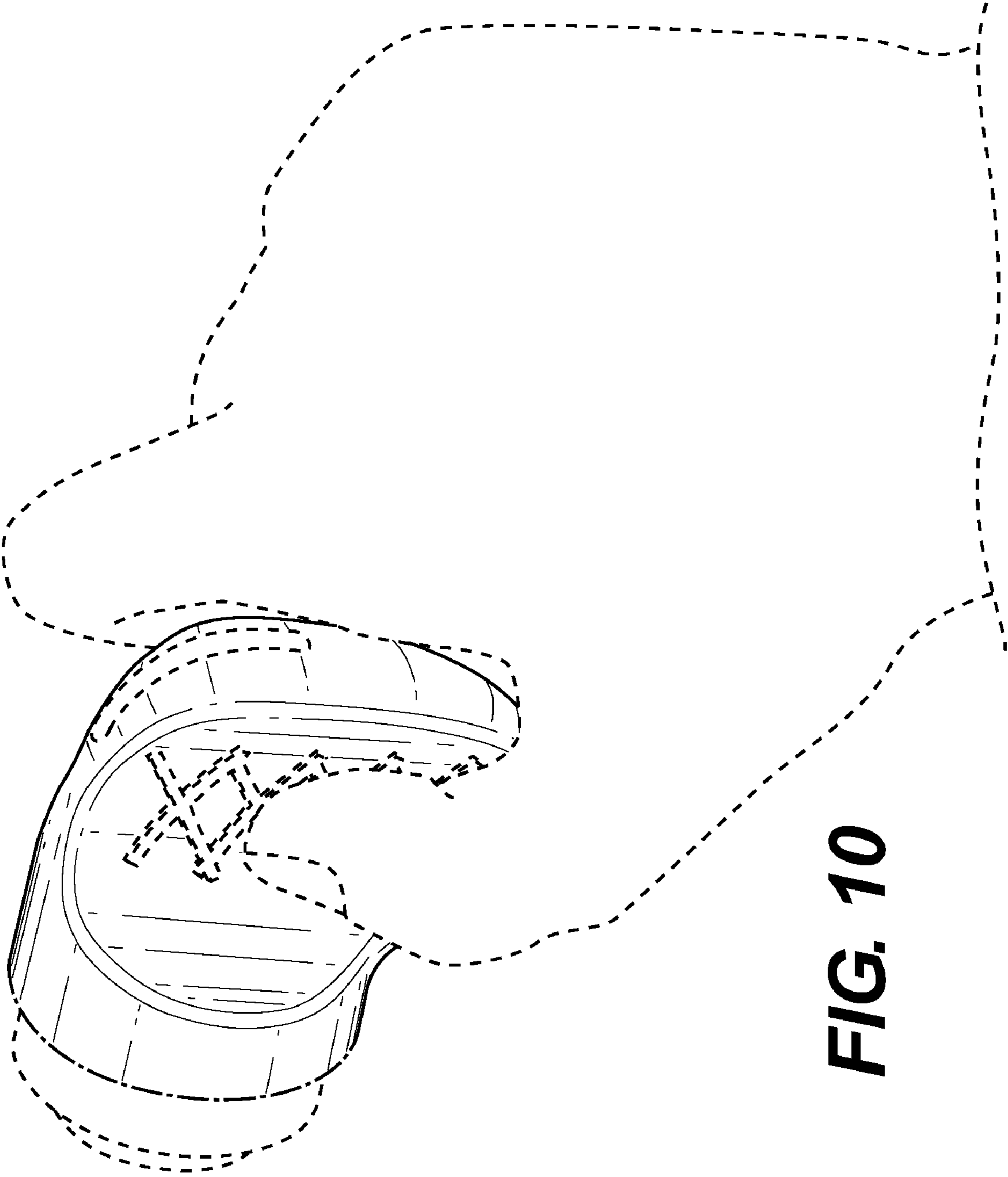

FIG. 10