

US00D635068S

(12) **United States Design Patent**
Neuchi et al.

(10) **Patent No.:** **US D635,068 S**
(45) **Date of Patent:** **** Mar. 29, 2011**

(54) **REAR BUMPER FOR AN AUTOMOBILE**

(75) Inventors: **Yoshiyasu Neuchi**, Kariya (JP); **Daisuke Nagayasu**, Kariya (JP)

(73) Assignee: **Toyota Jidosha Kabushiki Kaisha** (JP)

(**) Term: **14 Years**

(21) Appl. No.: **29/358,637**

(22) Filed: **Mar. 30, 2010**

(51) **LOC (9) Cl.** **12-16**

(52) **U.S. Cl.** **D12/169**

(58) **Field of Classification Search** D12/169,
D12/196, 171, 216, 163, 86, 90-92; 293/102,
293/113, 115, 117, 120; 296/180.1, 180.2
See application file for complete search history.

(56) **References Cited**

U.S. PATENT DOCUMENTS

D564,426 S *	3/2008	Okue	D12/169
D571,695 S *	6/2008	Zheng	D12/169
D600,602 S *	9/2009	Endoh	D12/169
D610,499 S *	2/2010	Truebsbach	D12/169

OTHER PUBLICATIONS

Ford Focus RS, Ford Motor Corporation, Auto Car, Haymarket, Feb. 25, 2010.

Subaru Impreza WRX STI, Impreza WRX STI-no-subete, Dec. 14, 2008.

* cited by examiner

Primary Examiner — Melody N Brown

(74) *Attorney, Agent, or Firm* — SAIDMAN DesignLaw Group

(57) **CLAIM**

The ornamental design for a rear bumper for an automobile, as shown and described.

DESCRIPTION

FIG. 1 is a front perspective view of a rear bumper for an automobile showing our new design;

FIG. 2 is a front view thereof;

FIG. 3 is a top view thereof;

FIG. 4 is a bottom view thereof;

FIG. 5 is a right-side view thereof; and,

FIG. 6 is a left-side view thereof.

1 Claim, 2 Drawing Sheets

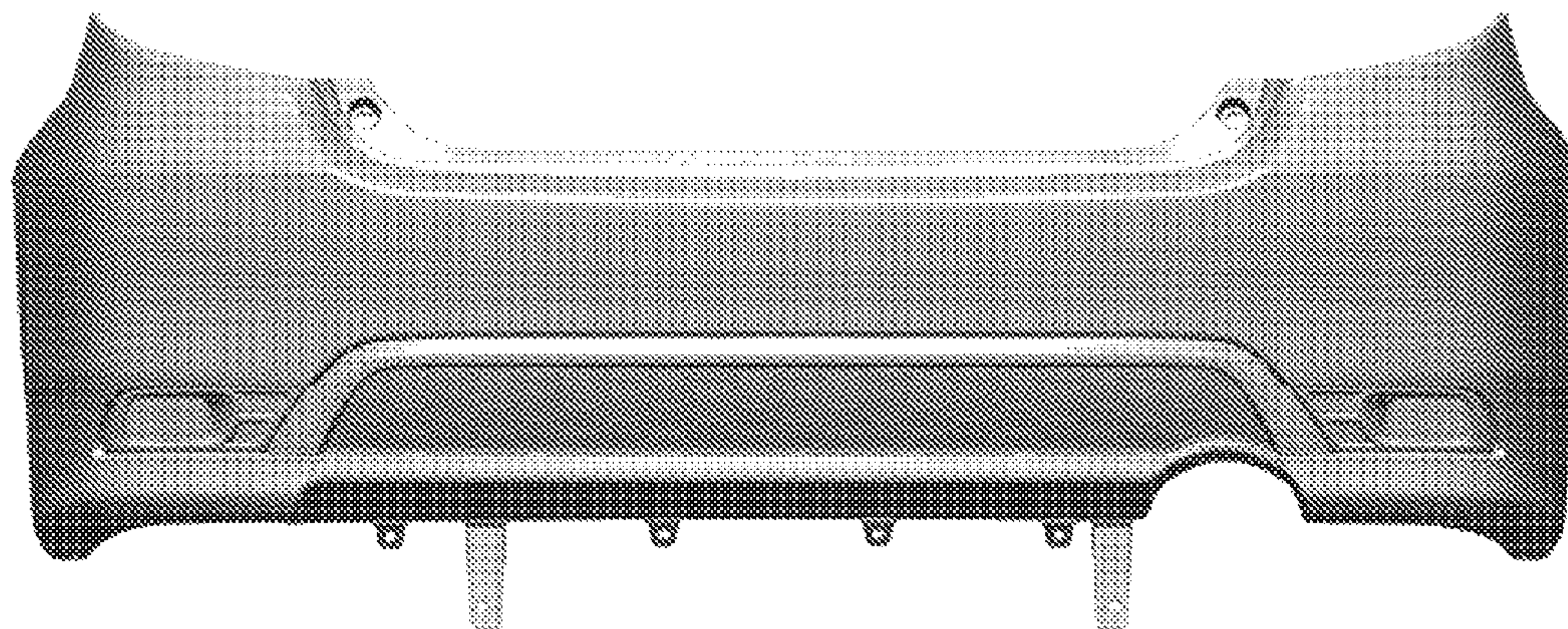

Fig. 1

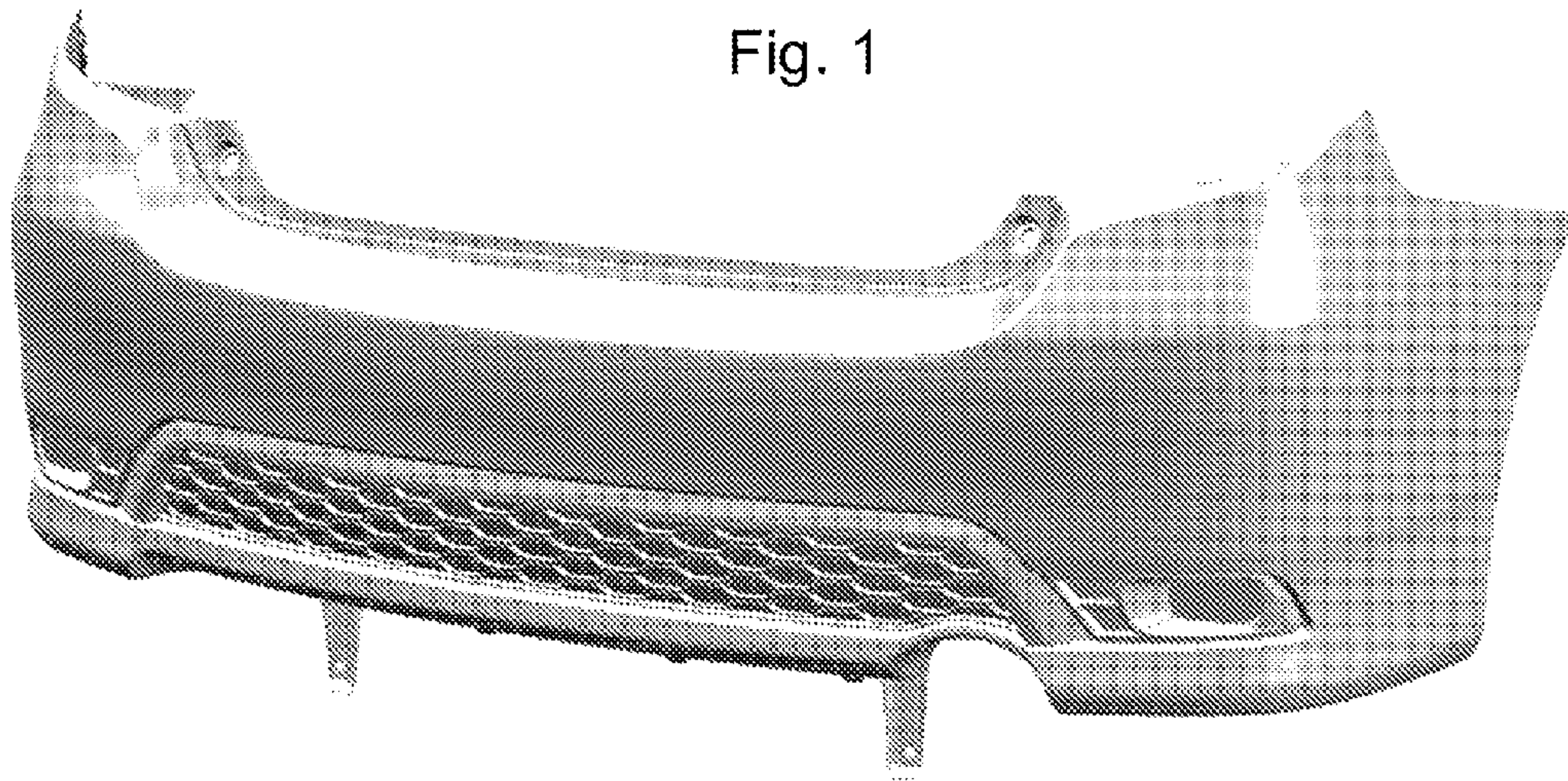

Fig. 2

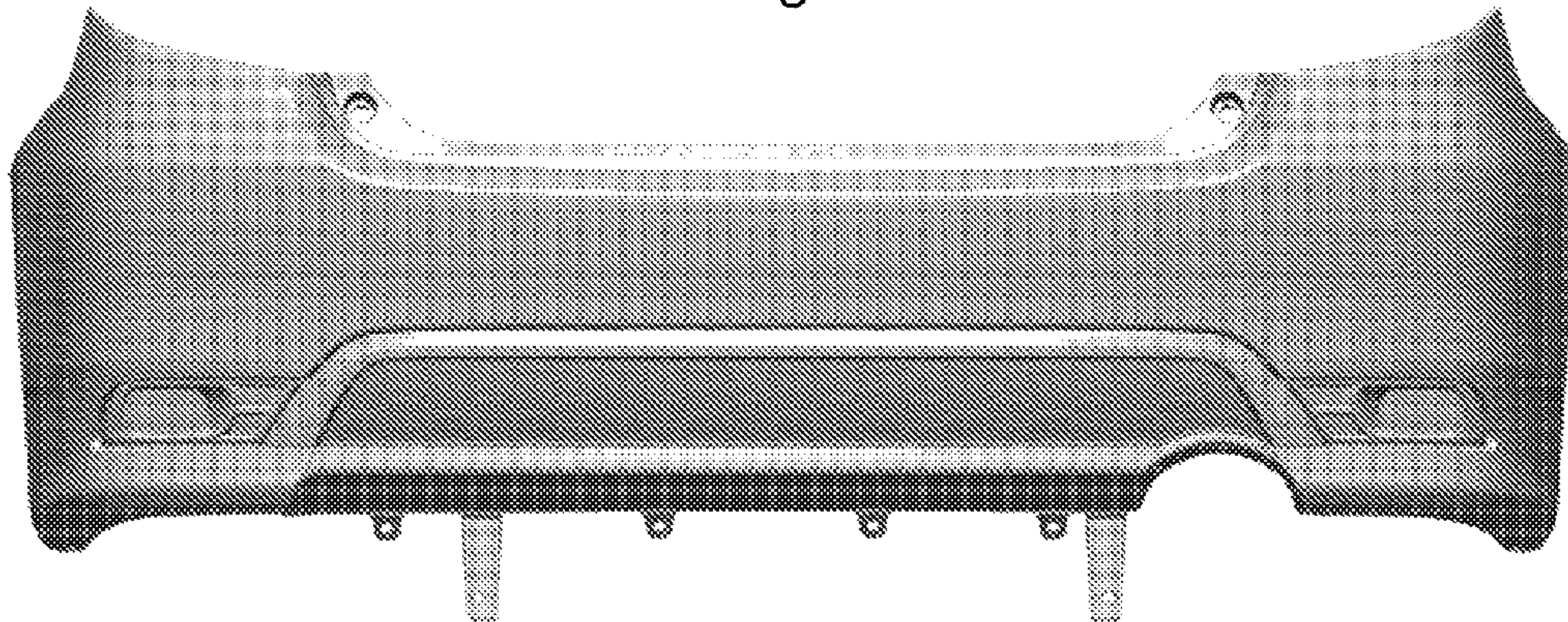
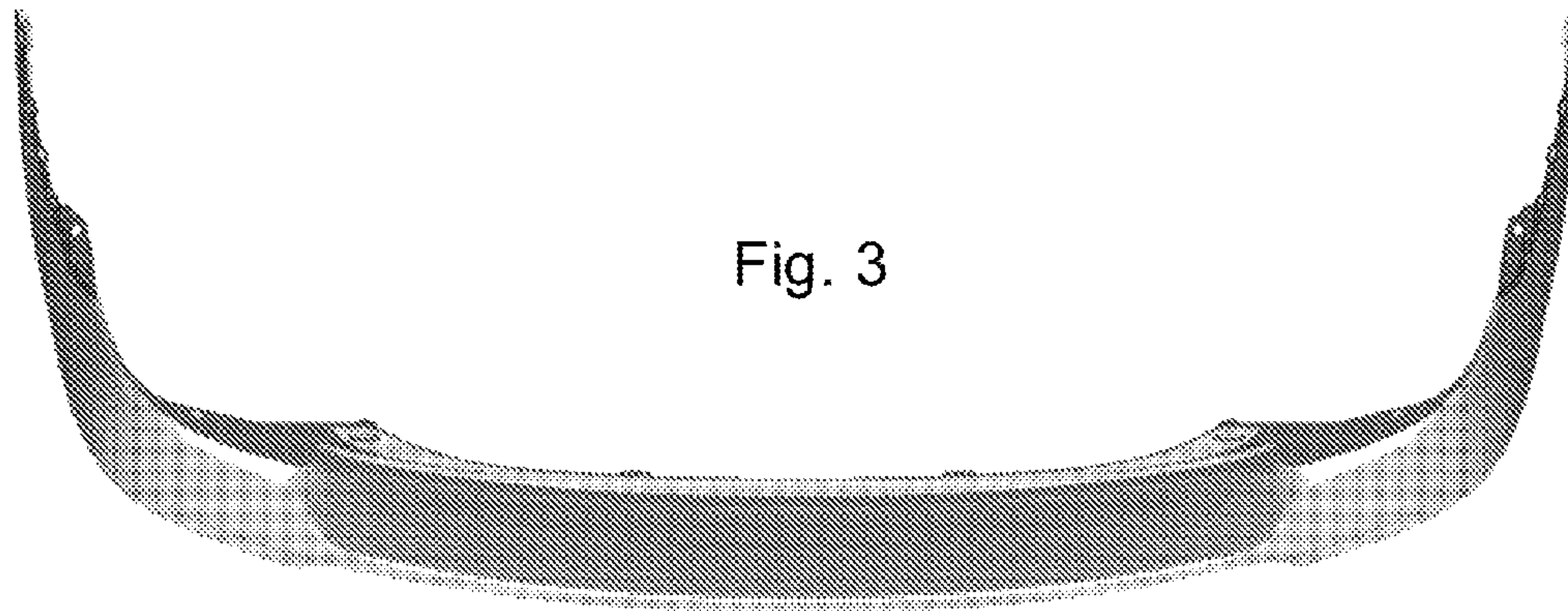

Fig. 3



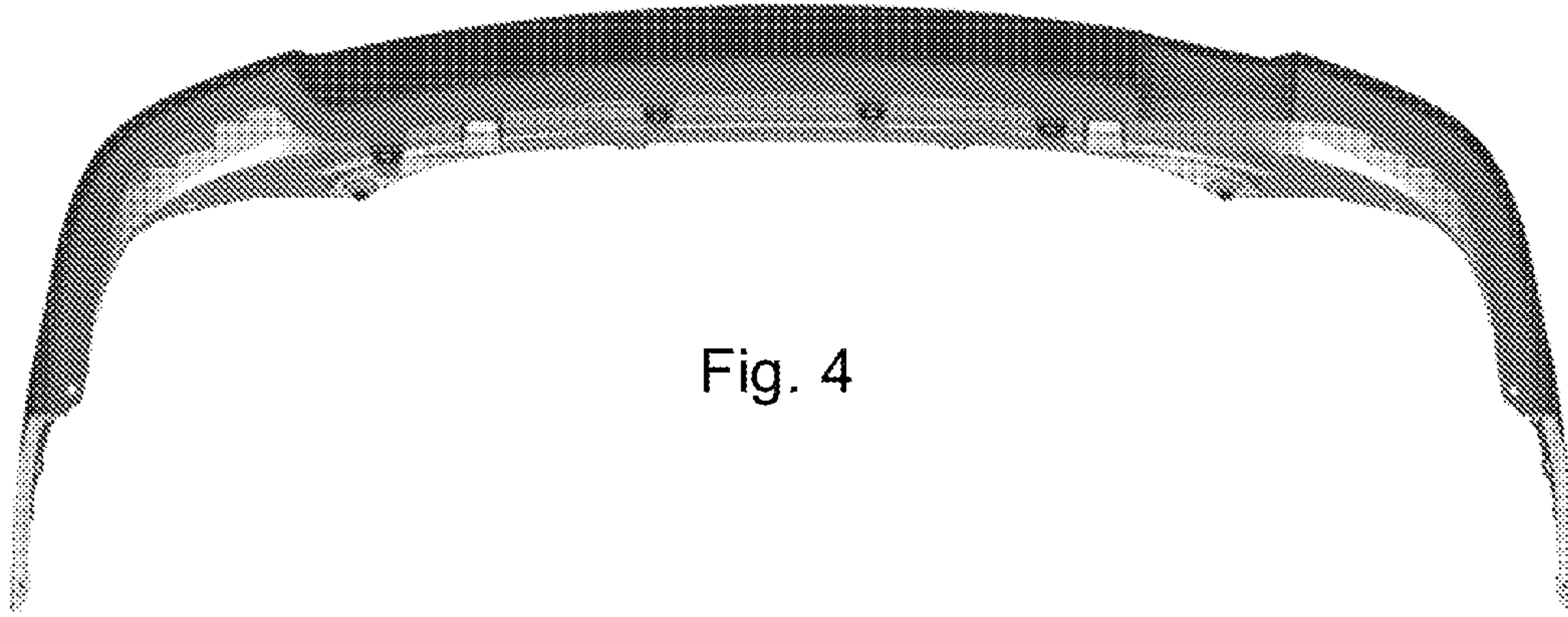

Fig. 4

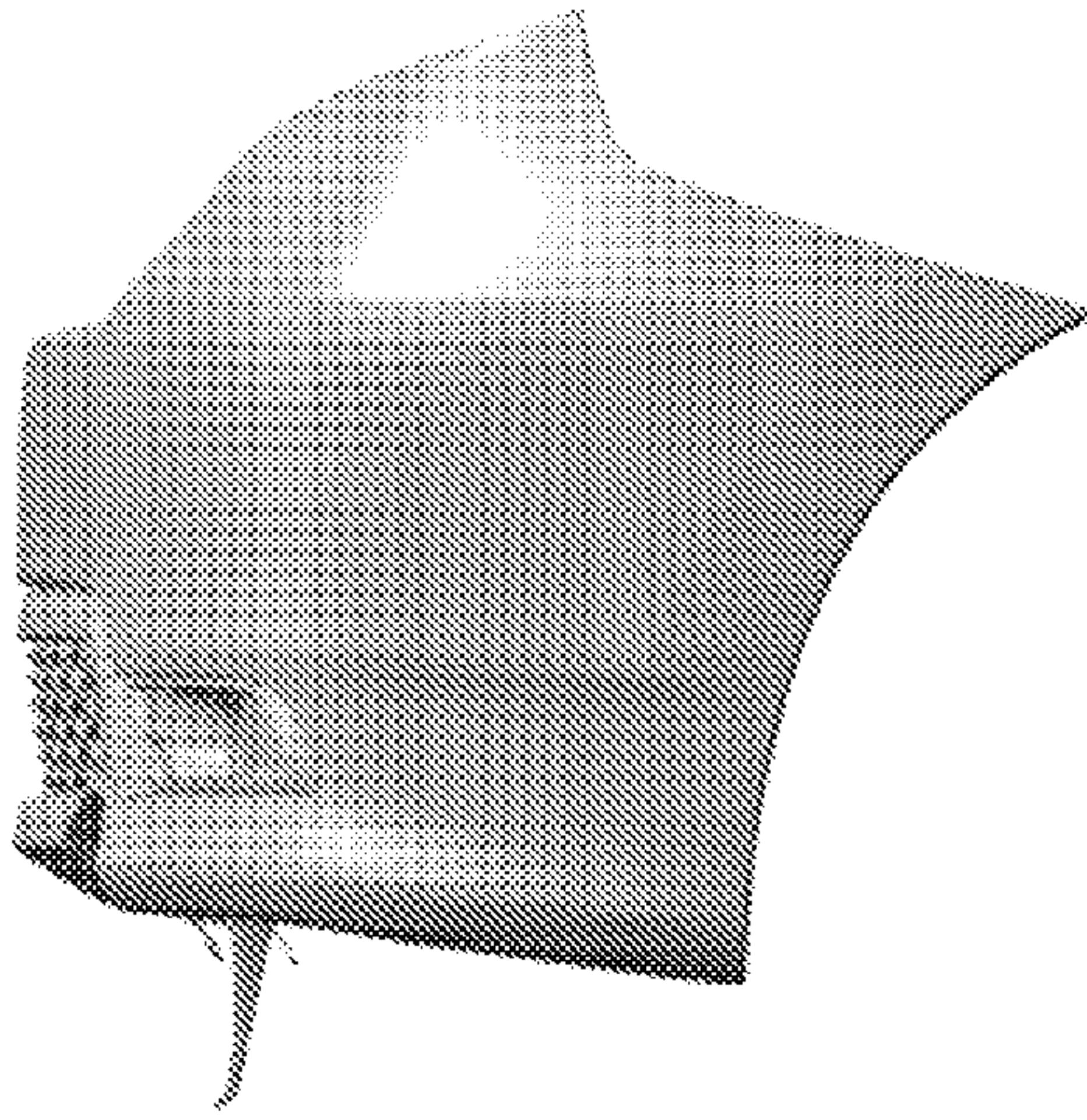

Fig. 5

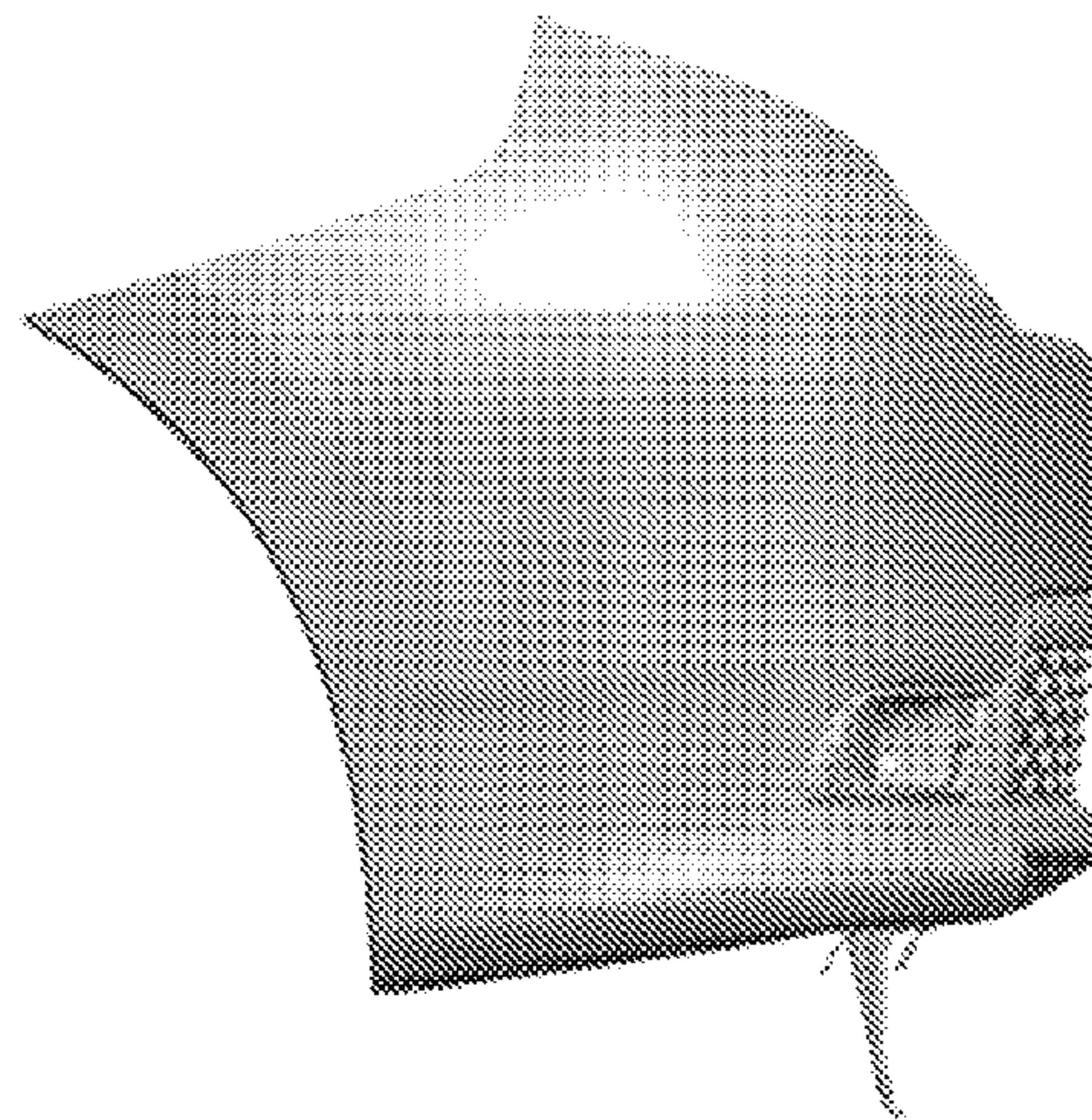

Fig. 6