



US00D634954S

(12) **United States Design Patent**  
**Montoya**

(10) **Patent No.:** **US D634,954 S**

(45) **Date of Patent:** **\*\* \*Mar. 29, 2011**

(54) **TISSUE BOX**

6,405,972 B1 \* 6/2002 Wakam ..... 242/597.7  
D467,106 S \* 12/2002 Bohay ..... D6/523  
D478,753 S \* 8/2003 Hall et al. .... D6/523

(76) Inventor: **Ronald Allen Montoya**, Las Vegas, NV  
(US)

\* cited by examiner

(\*) Notice: This patent is subject to a terminal disclaimer.

*Primary Examiner* — Brian N Vinson

(74) *Attorney, Agent, or Firm* — Weide & Miller, Ltd.

(\*\*) Term: **14 Years**

(57) **CLAIM**

The ornamental design for a tissue box, as shown and described.

(21) Appl. No.: **29/328,351**

(22) Filed: **Nov. 22, 2008**

**DESCRIPTION**

(51) **LOC (9) Cl.** ..... **23-02**

(52) **U.S. Cl.** ..... **D6/523**

(58) **Field of Classification Search** ..... D6/518–524,  
D6/546–550; 108/28–29; 211/13.1, 16,  
211/60.1, 86.01, 87.01, 88.01, 88.04, 100,  
211/105.1, 105.2, 123, 181.1, 182; 248/175,  
248/176.1, 251, 302; 16/110.1, 415; 242/570,  
242/590, 595–598; D8/300, 303, 315–321;  
220/216

See application file for complete search history.

FIG. 1 is a top, front, and right side perspective view of a tissue box showing my new design;

FIG. 2 is an exploded top, front, and right side perspective view thereof, with the broken-line disclosure being understood to represent a portion of the article in which the claimed design resides, but forms no part of the claimed design;

FIG. 3 is a top plan view thereof, the undisclosed bottom being plain and unornamented;

FIG. 4 is a front elevational view thereof, the sides adjacent and rear being identical in appearance to that shown; and,

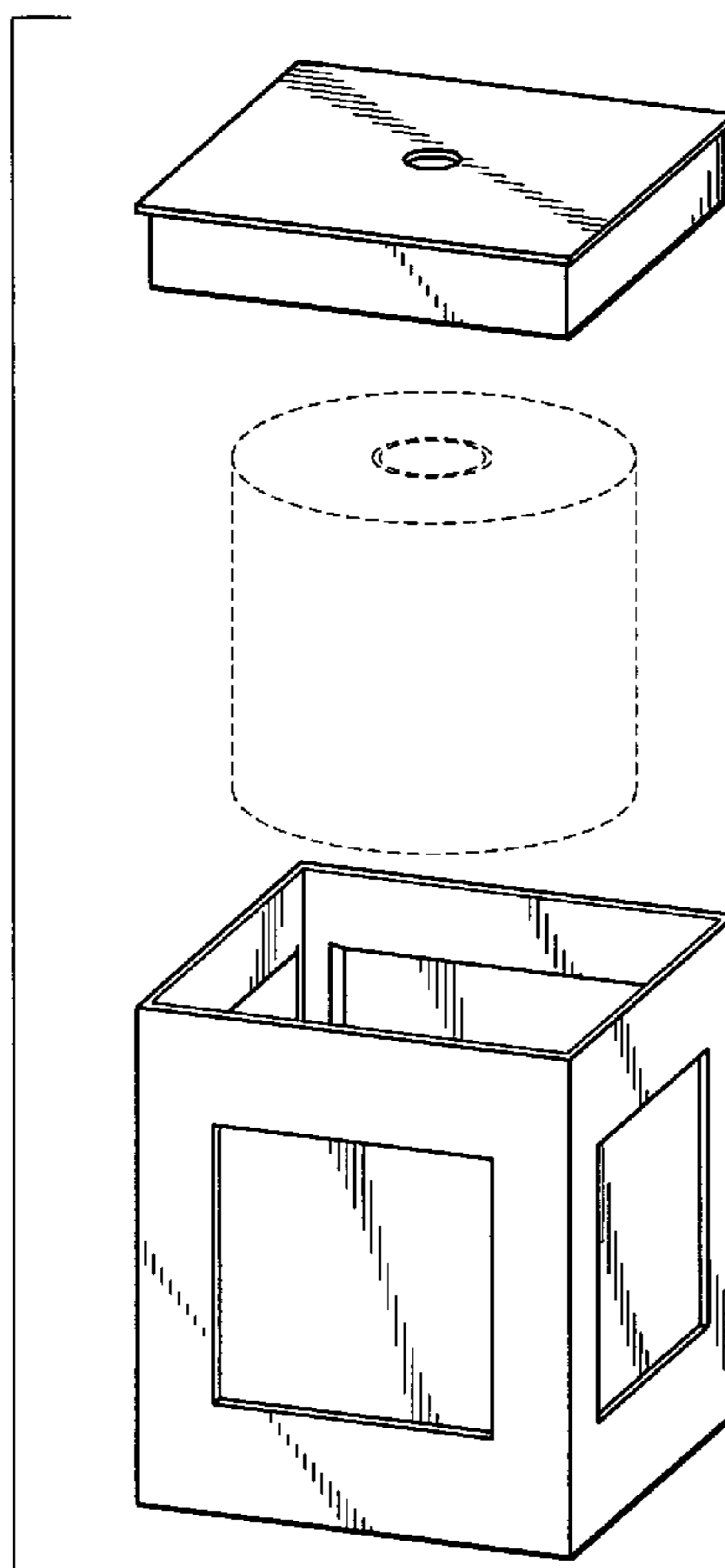
FIG. 5 is a horizontal cross sectional view thereof, taken along line 5—5 of FIG. 4, with the broken-line disclosure being understood to represent a portion of the article in which the claimed design resides, but forms no part of the claimed design.

(56) **References Cited**

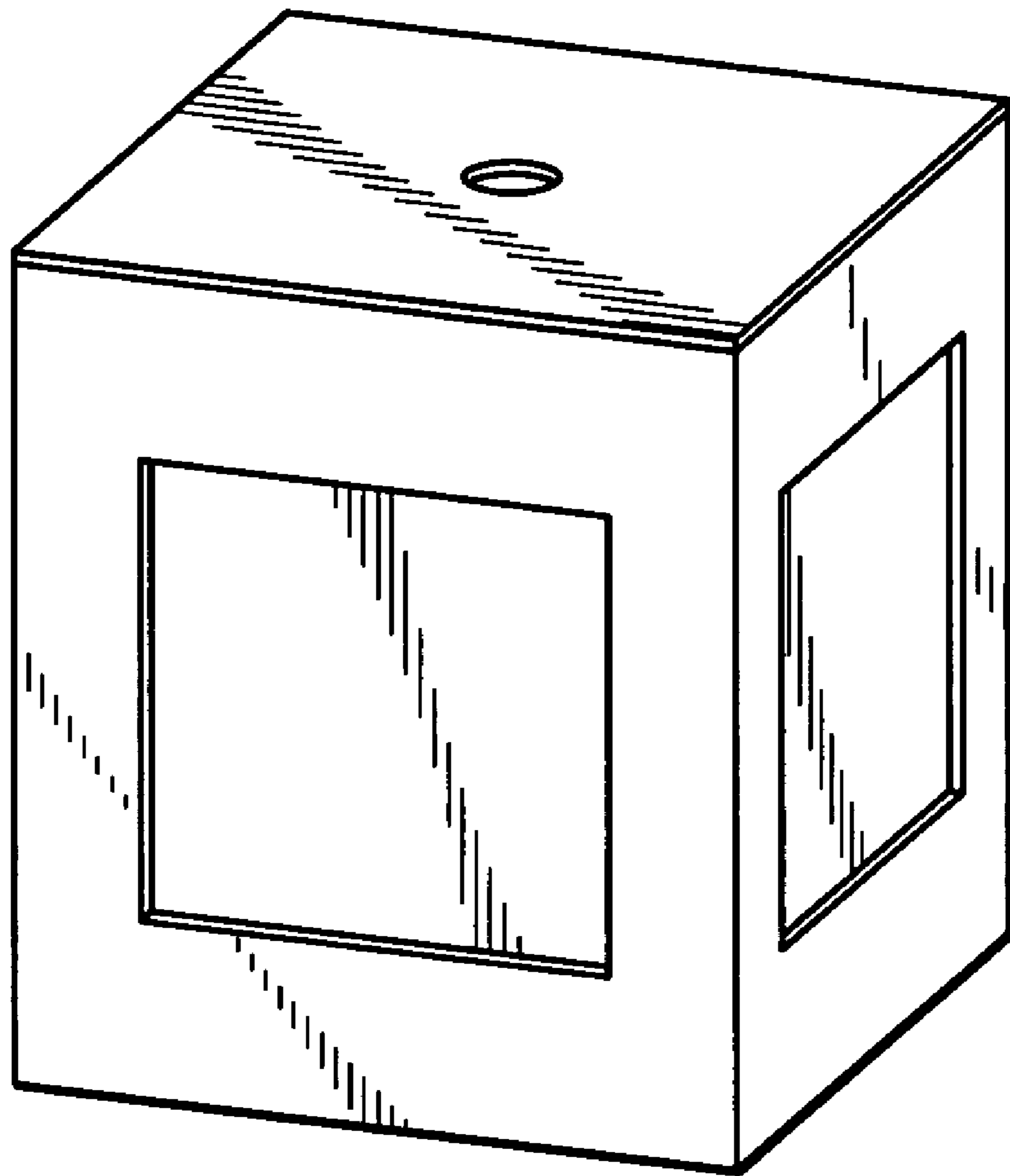
U.S. PATENT DOCUMENTS

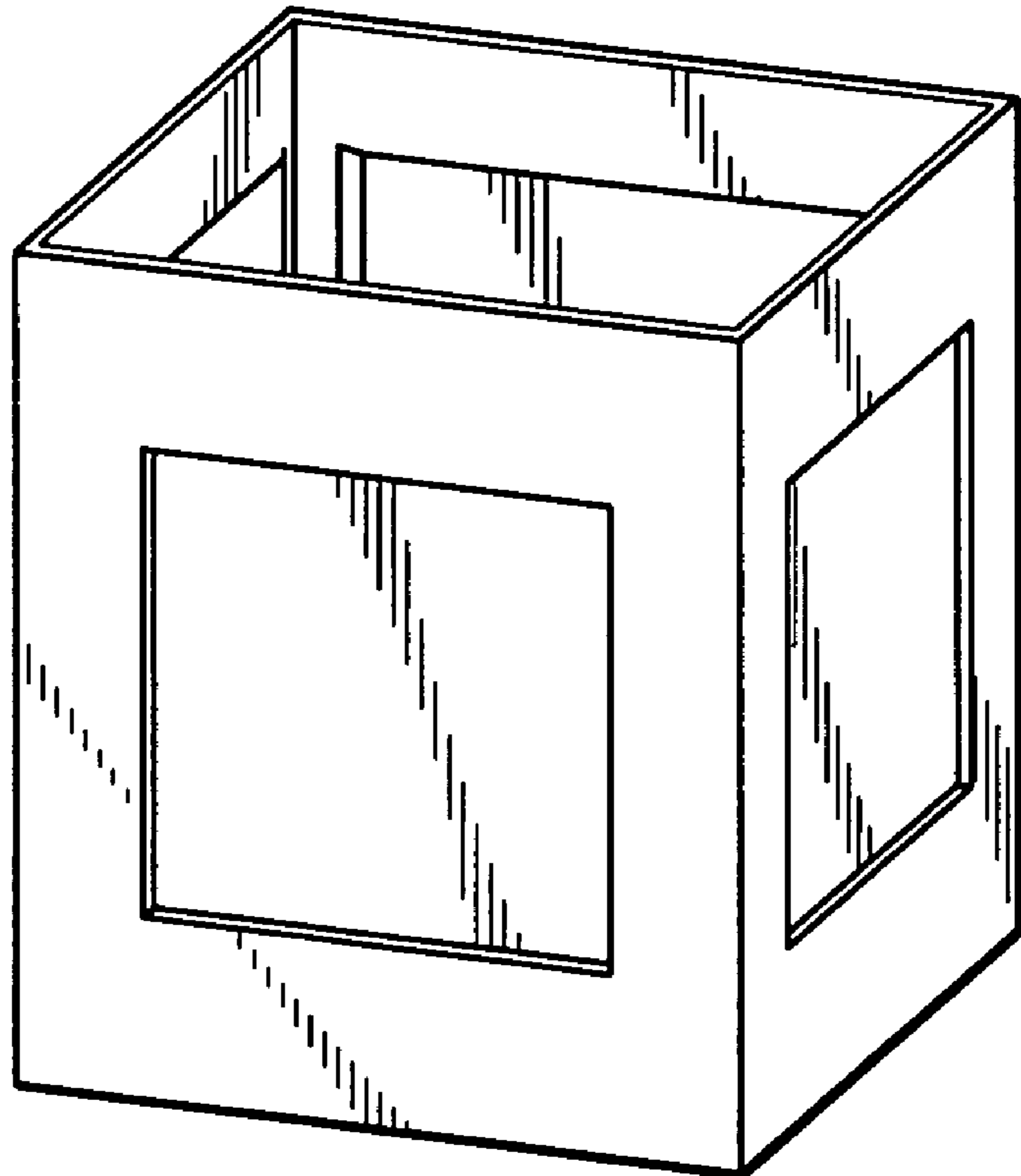
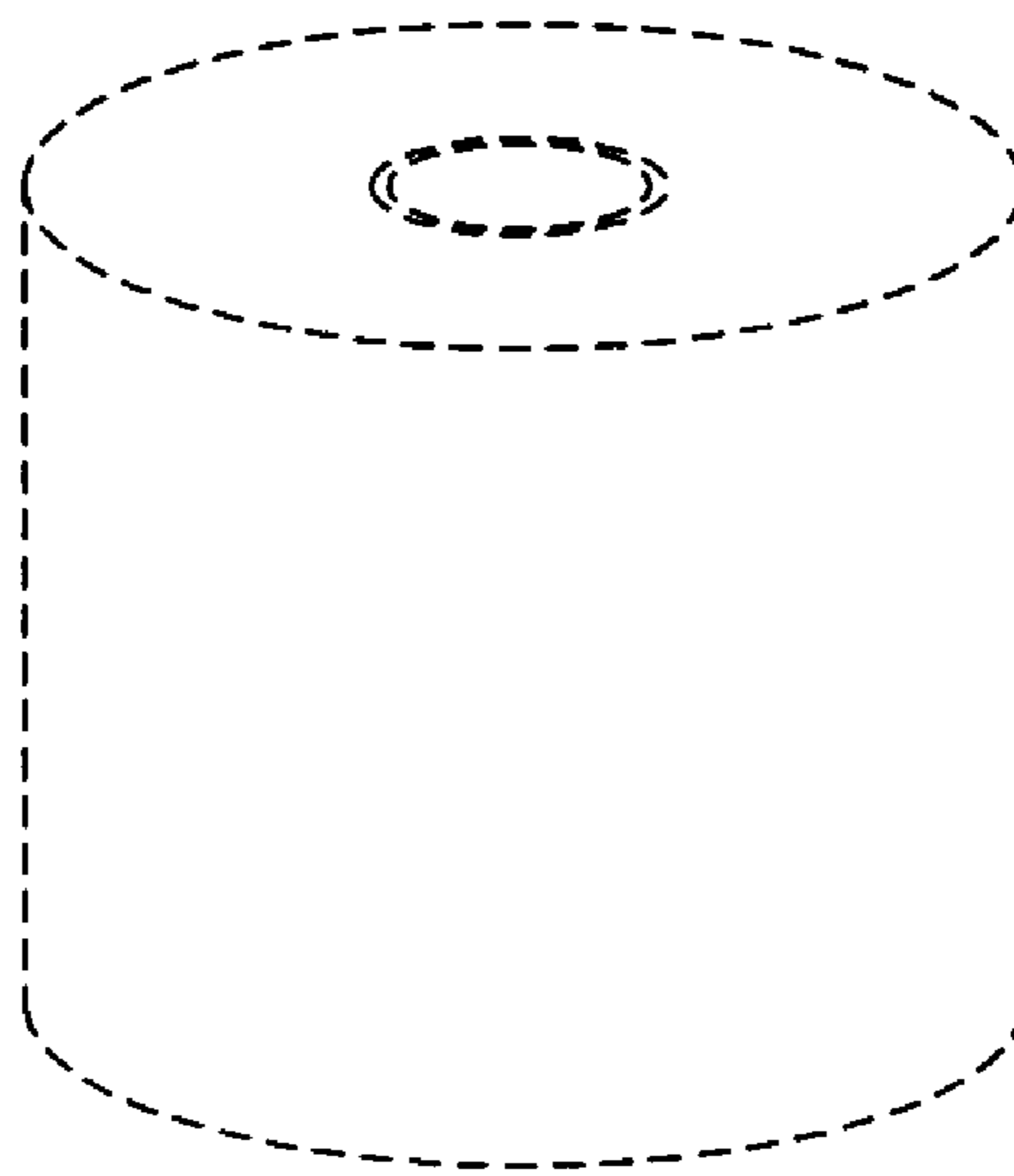
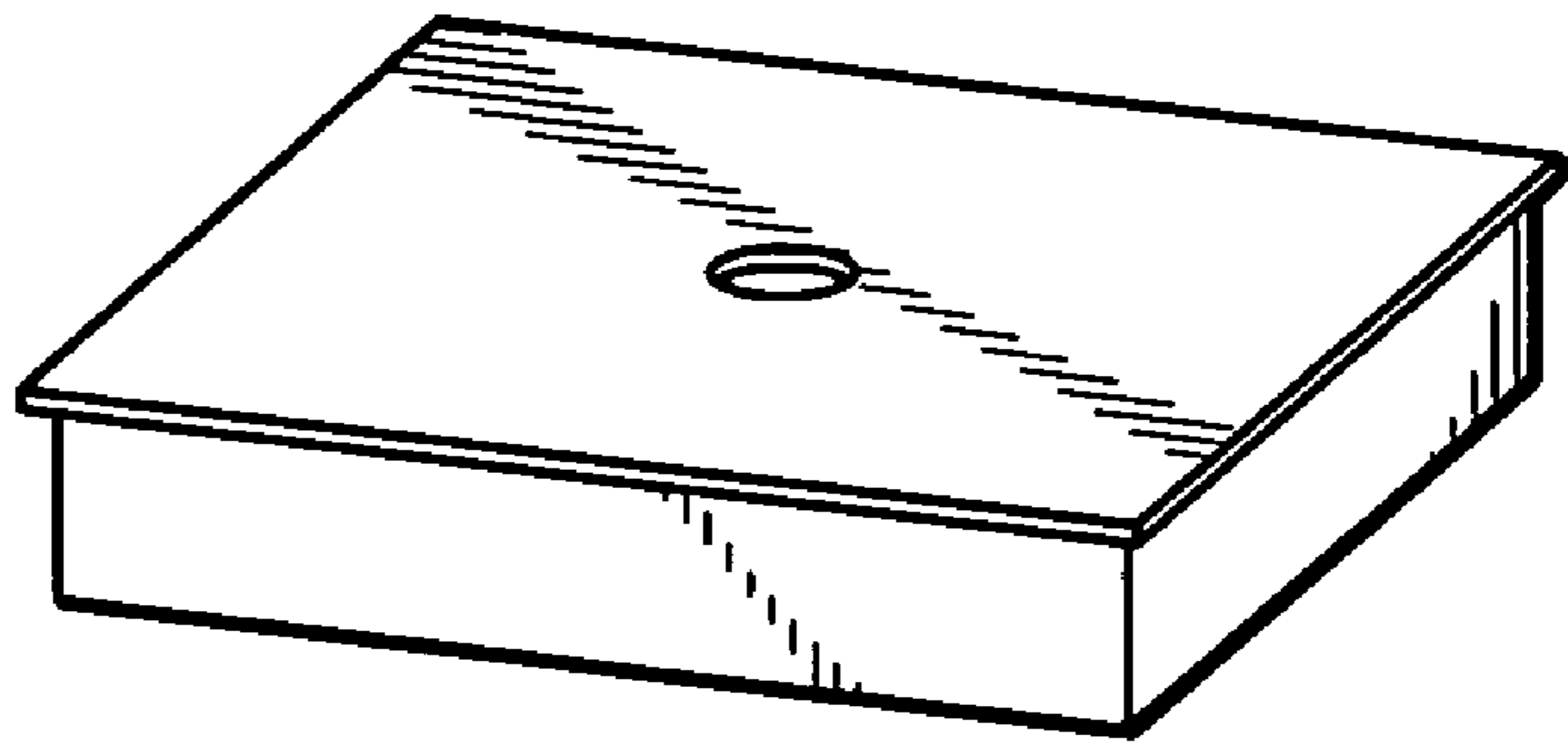
3,704,776 A \* 12/1972 Collins ..... 206/216  
D344,425 S \* 2/1994 Balanesi ..... D6/523  
D418,705 S \* 1/2000 Wakam ..... D6/523  
D458,785 S \* 6/2002 Ong ..... D6/518

**1 Claim, 3 Drawing Sheets**



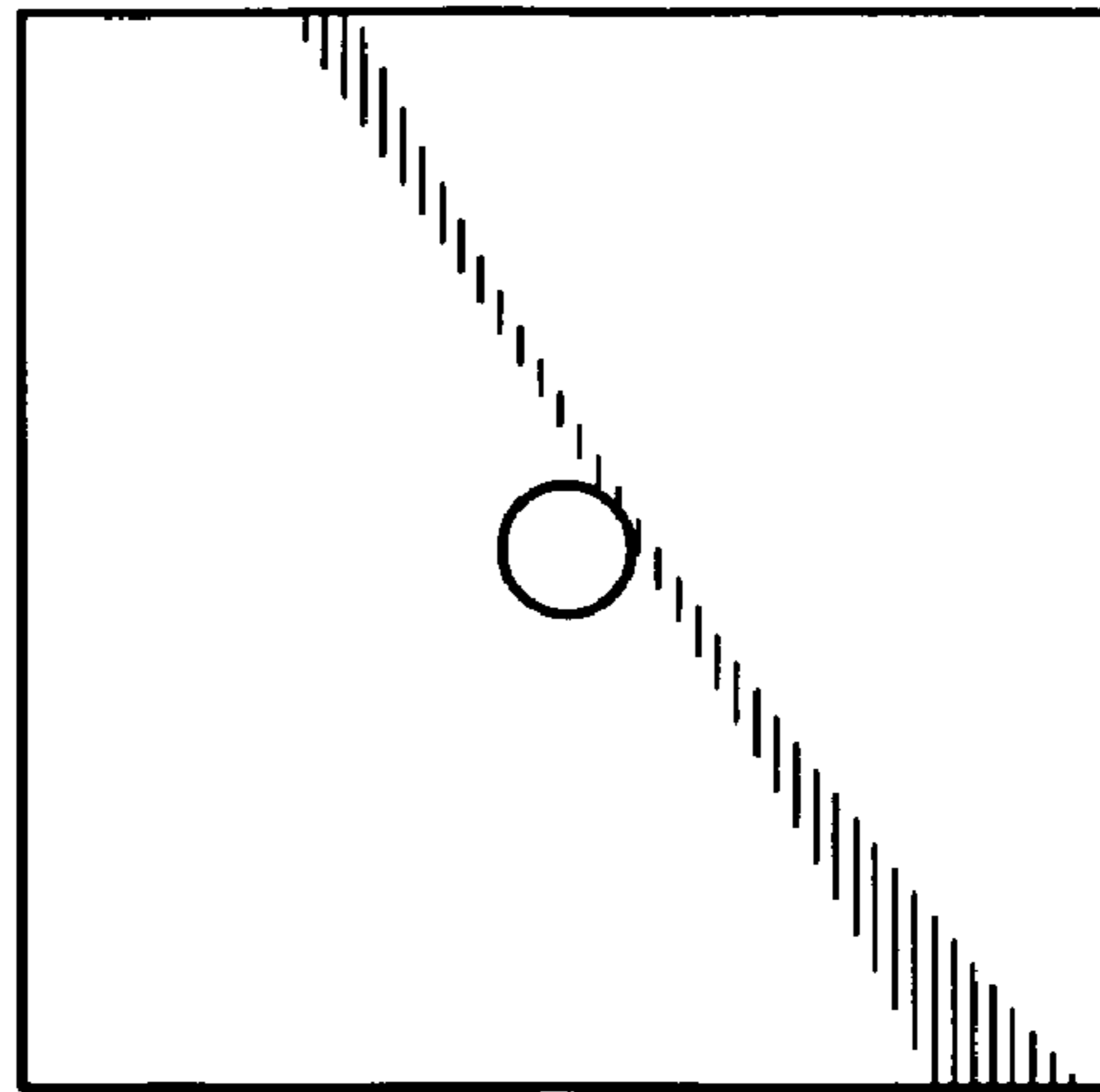
**FIG. 1**



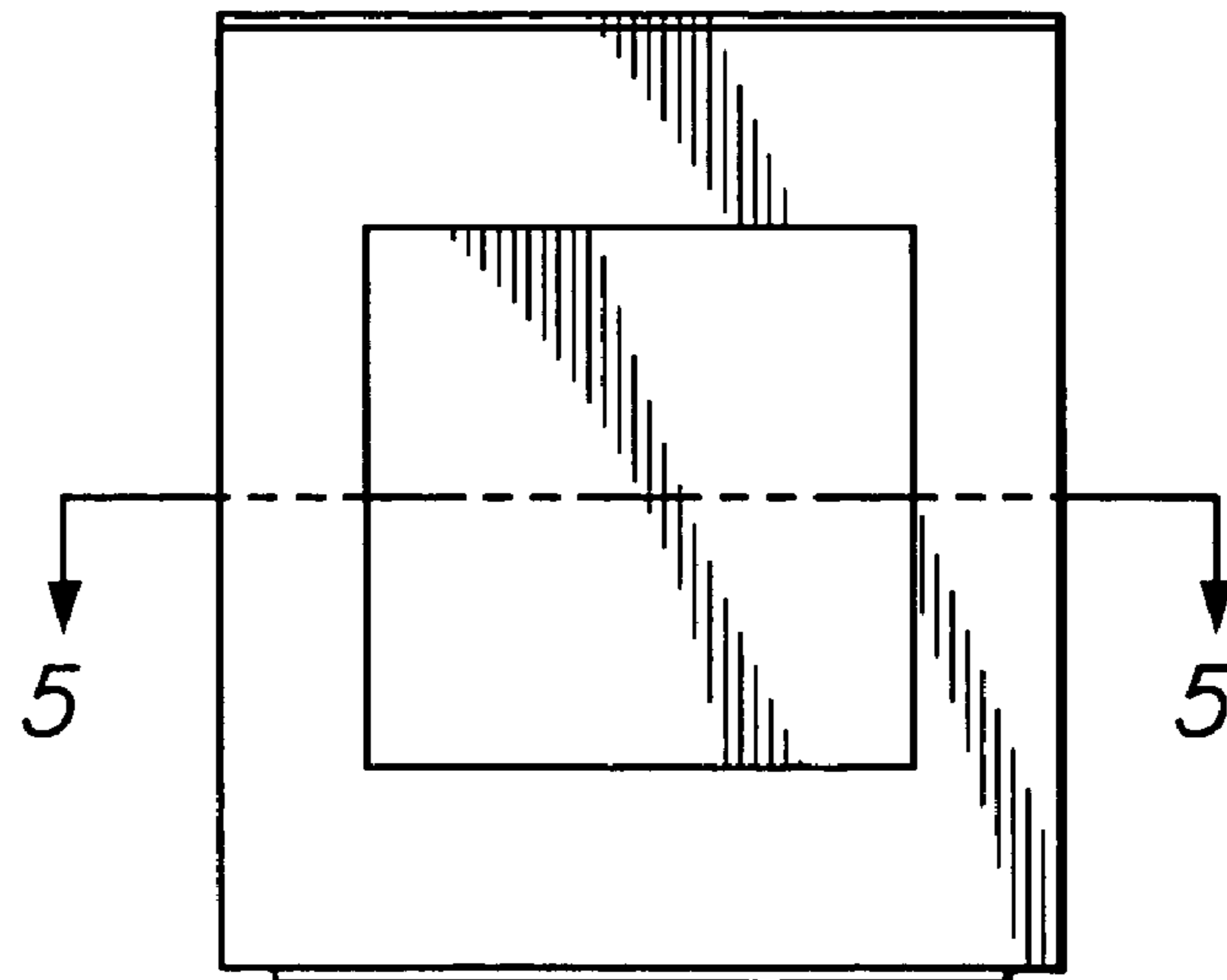


**FIG. 2**

**FIG. 3**



**FIG. 4**



**FIG. 5**

