



US00D634758S

(12) **United States Design Patent**
Mack

(10) **Patent No.:** **US D634,758 S**

(45) **Date of Patent:** **** Mar. 22, 2011**

(54) **UTILITY VEHICLE**

(75) Inventor: **Manfred Mack**, DE-Salem (DE)

(73) Assignee: **Kramer-Werke GmbH**, Pfullendorf (DE)

(**) Term: **14 Years**

(21) Appl. No.: **29/347,915**

(22) Filed: **Jul. 27, 2010**

(30) **Foreign Application Priority Data**

Jan. 28, 2010 (EM) 001662438

(51) **LOC (9) Cl.** **15-03**

(52) **U.S. Cl.** **D15/10; D15/22; D15/33**

(58) **Field of Classification Search** D15/10,
D15/22-26, 33; D34/28, 34; D12/14; 180/89.1,
180/89.12; 414/685, 694, 722; 37/407, 442
See application file for complete search history.

(56) **References Cited**

U.S. PATENT DOCUMENTS

D271,397 S *	11/1983	Kuhn et al.	D15/25
D297,539 S *	9/1988	Morita et al.	D15/23
5,199,861 A *	4/1993	Merlo et al.	414/718
D353,704 S *	12/1994	Bhambra	D34/37
5,778,569 A *	7/1998	Schaeff	37/410

D438,359 S *	2/2001	Braud	D34/34
D461,831 S *	8/2002	Laberheim et al.	D15/25
D464,661 S *	10/2002	Dahl et al.	D15/23
D598,030 S *	8/2009	Schell et al.	D15/22
D609,721 S *	2/2010	Schmidt	D15/23
D609,722 S *	2/2010	Schmidt	D15/23
D609,723 S *	2/2010	Schmidt	D15/23
D610,168 S *	2/2010	Schmidt	D15/23
D610,169 S *	2/2010	Schmidt	D15/23
D610,170 S *	2/2010	Schmidt	D15/23

* cited by examiner

Primary Examiner — Mark A Goodwin

(74) *Attorney, Agent, or Firm* — Breneman & Georges

(57) **CLAIM**

The ornamental design for a utility vehicle, as shown and described.

DESCRIPTION

FIG. 1 is a left side elevational view of a utility vehicle showing my new design;
FIG. 2 is an end elevational view thereof;
FIG. 3 is a right side elevational view thereof;
FIG. 4 is an opposite end elevational view thereof;
FIG. 5 is a perspective view thereof;
FIG. 6 is a top plan view thereof; and,
FIG. 7 is a bottom plan view thereof.

In the drawings, the broken lines showing tires, wheels, loading device, mirror, windshield wipers, and accessories depict environmental subject matter and forms no part of the claim.

1 Claim, 7 Drawing Sheets

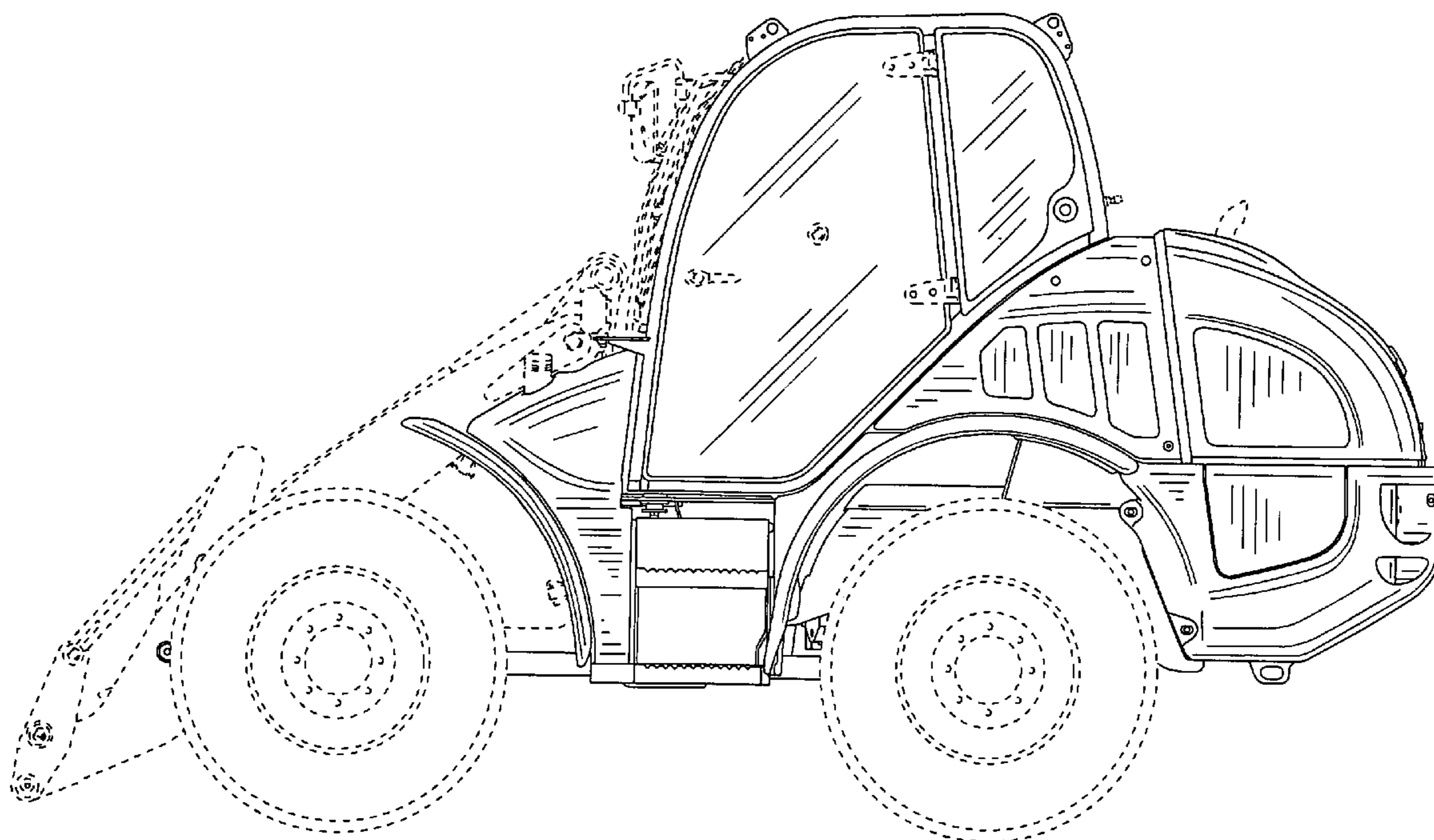

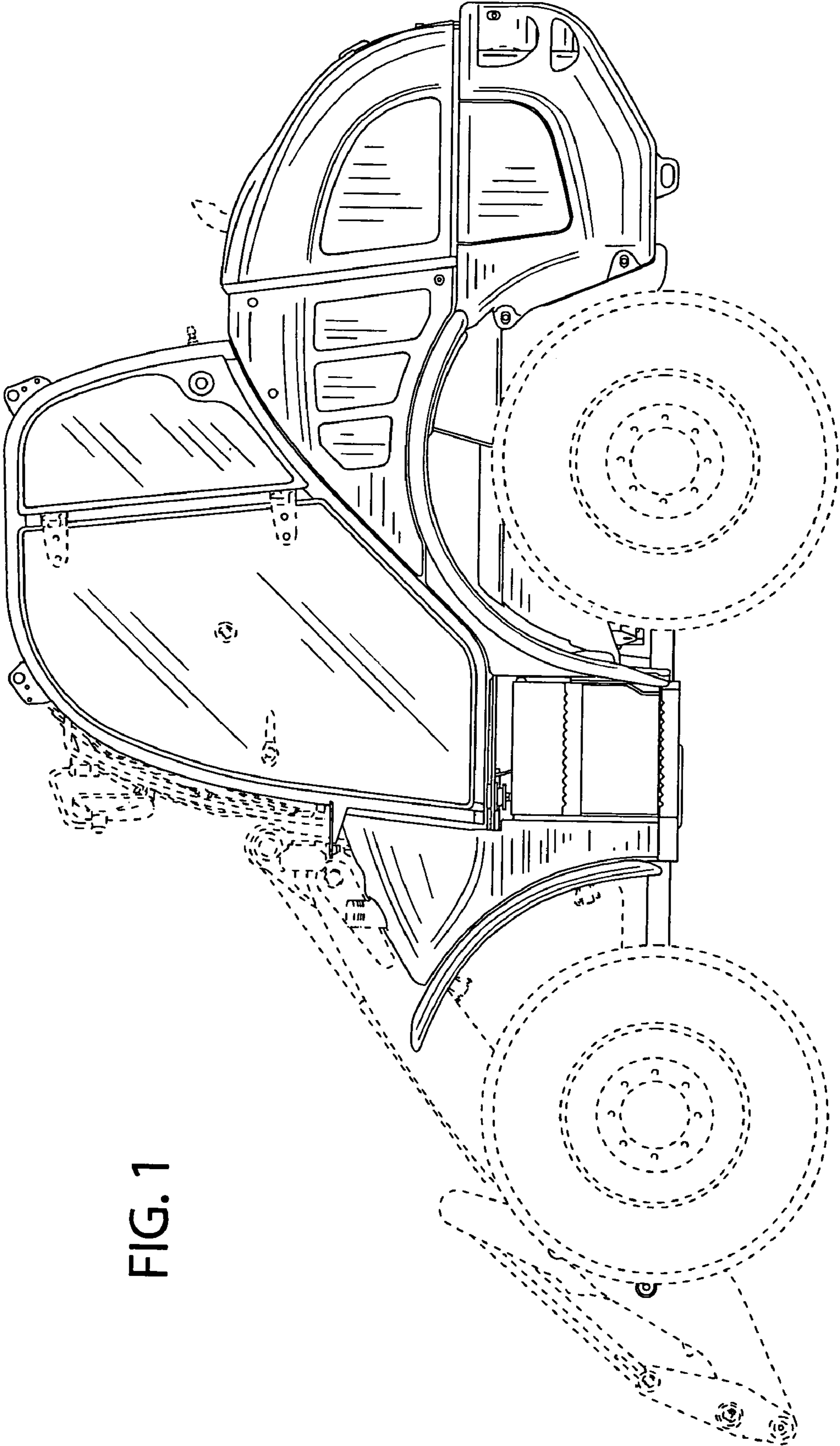

FIG. 1

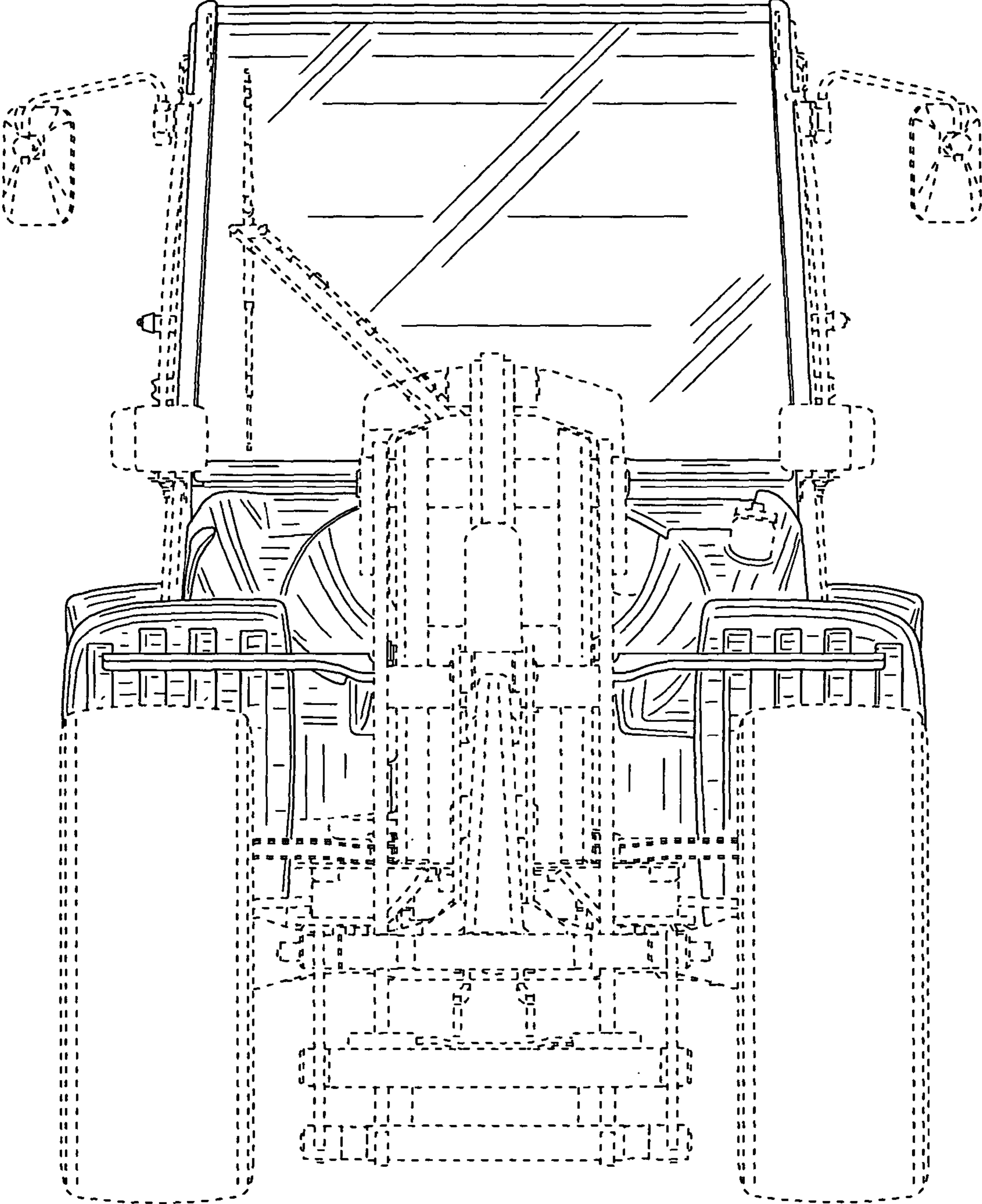
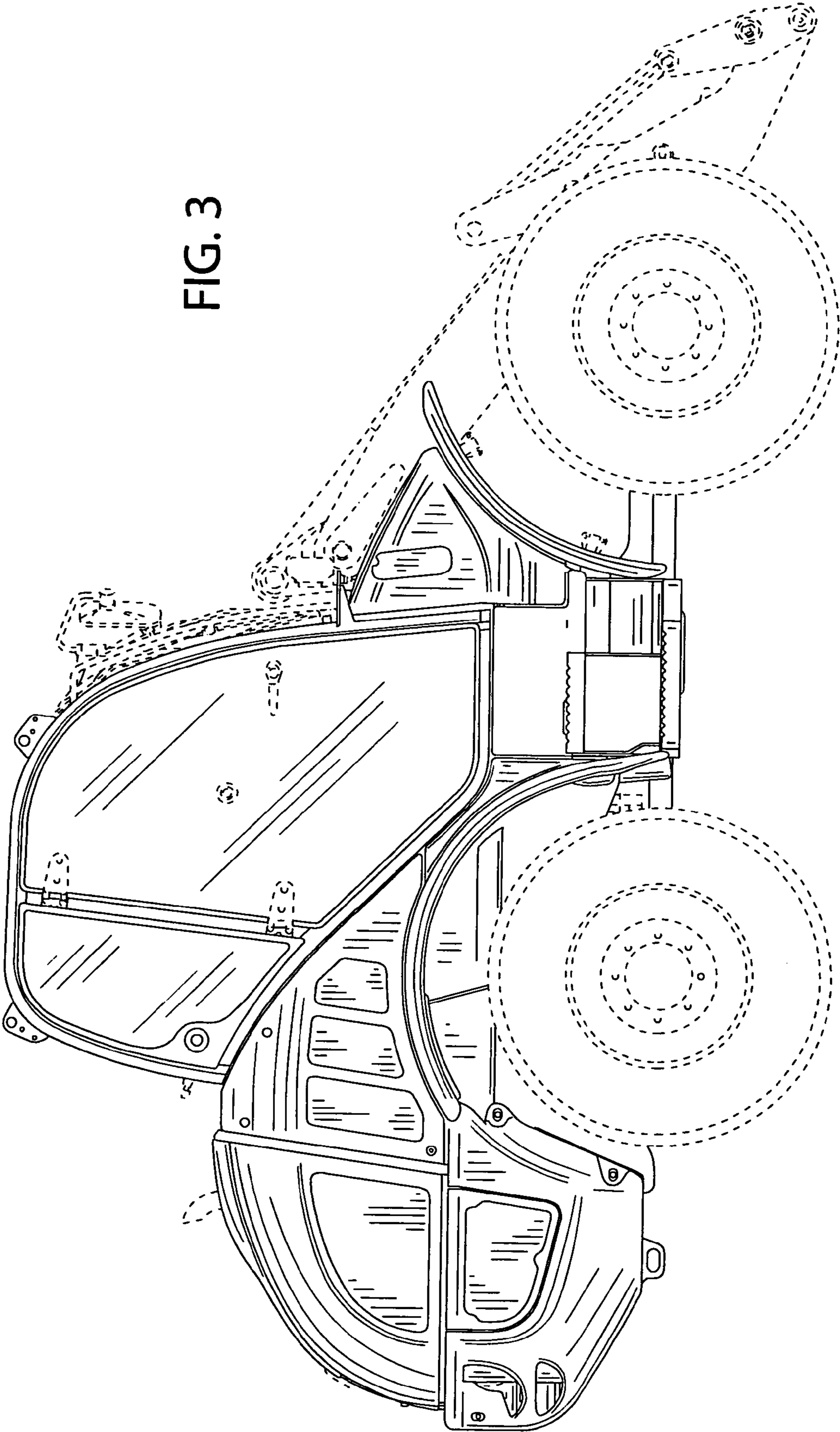

FIG. 2

FIG. 3



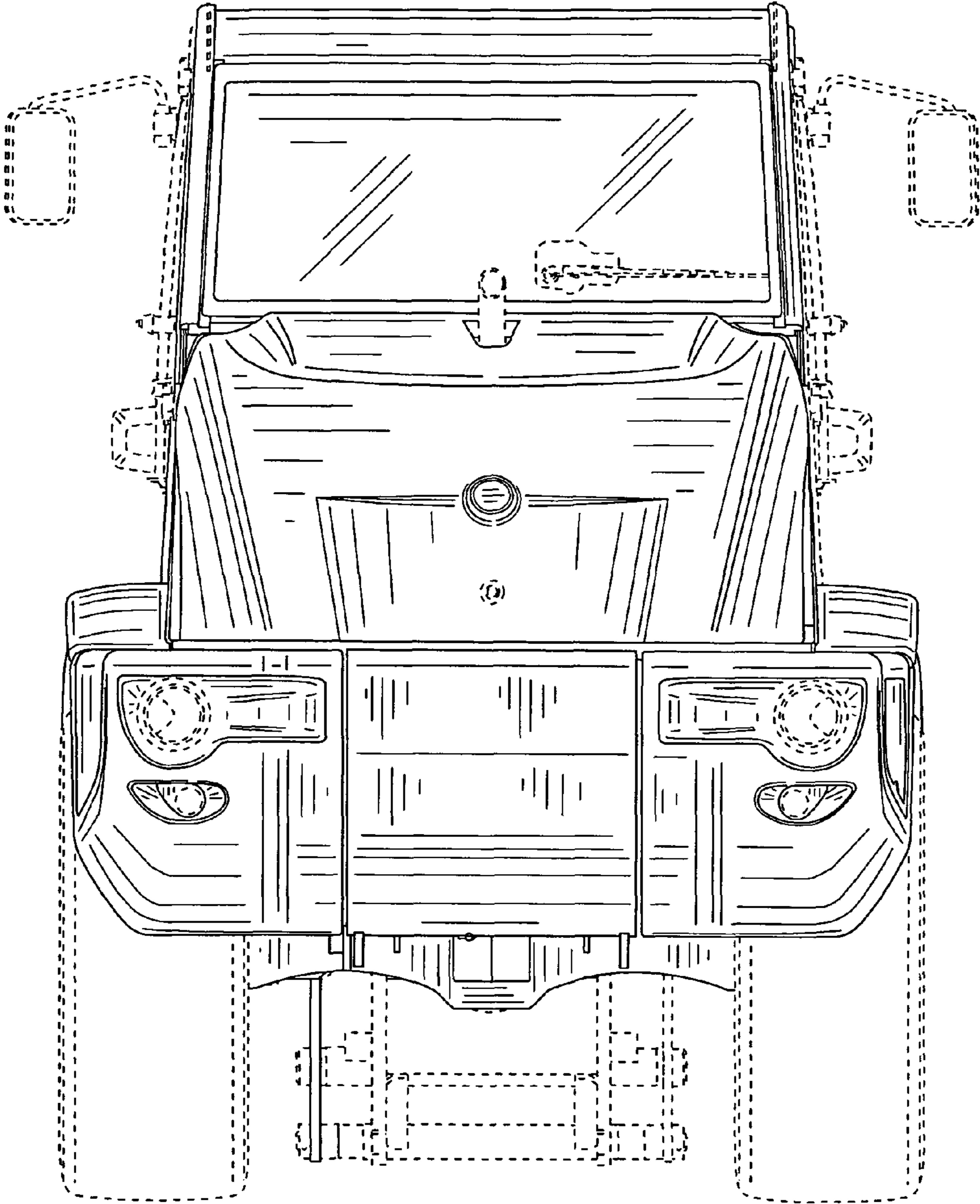

FIG. 4

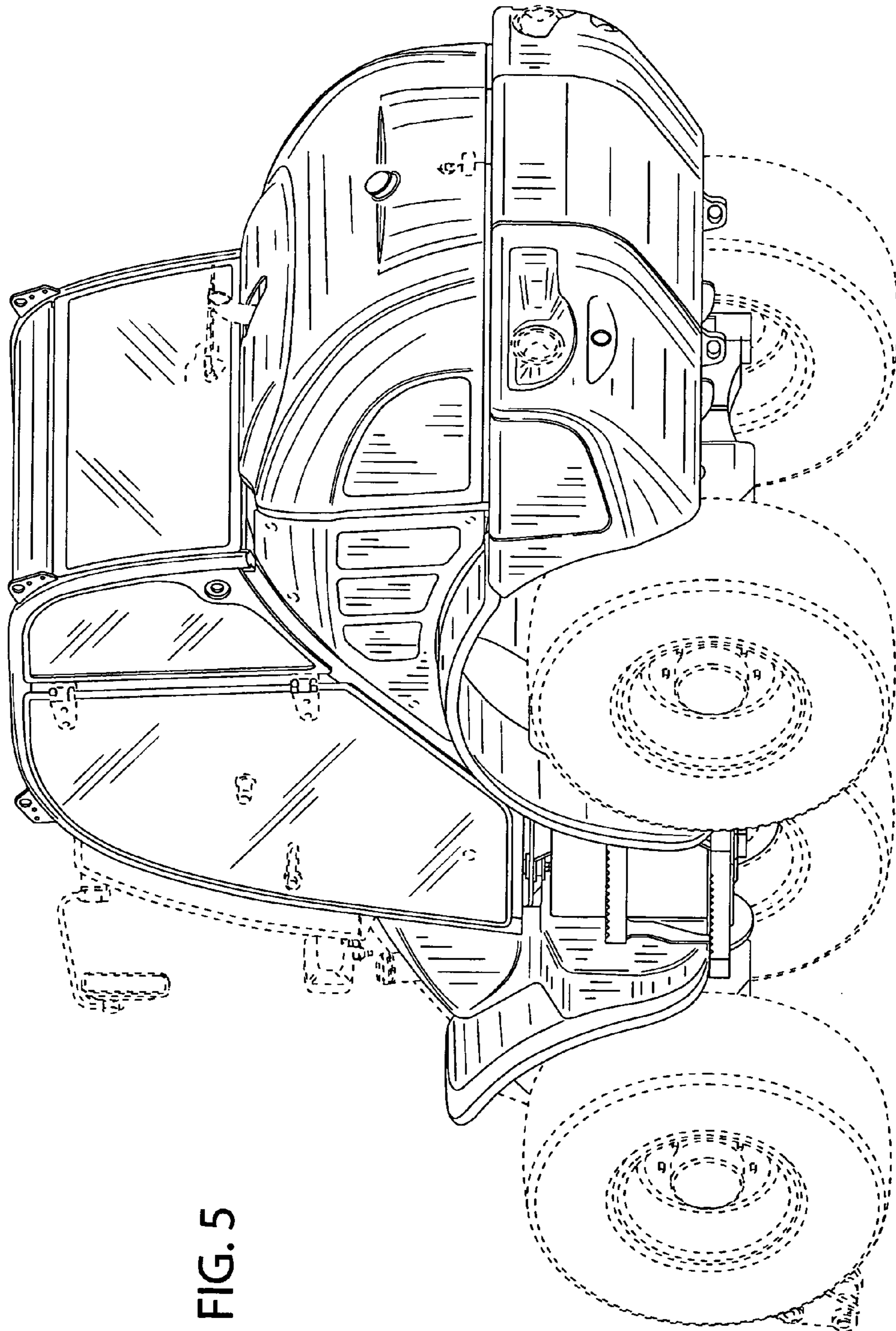

FIG. 5

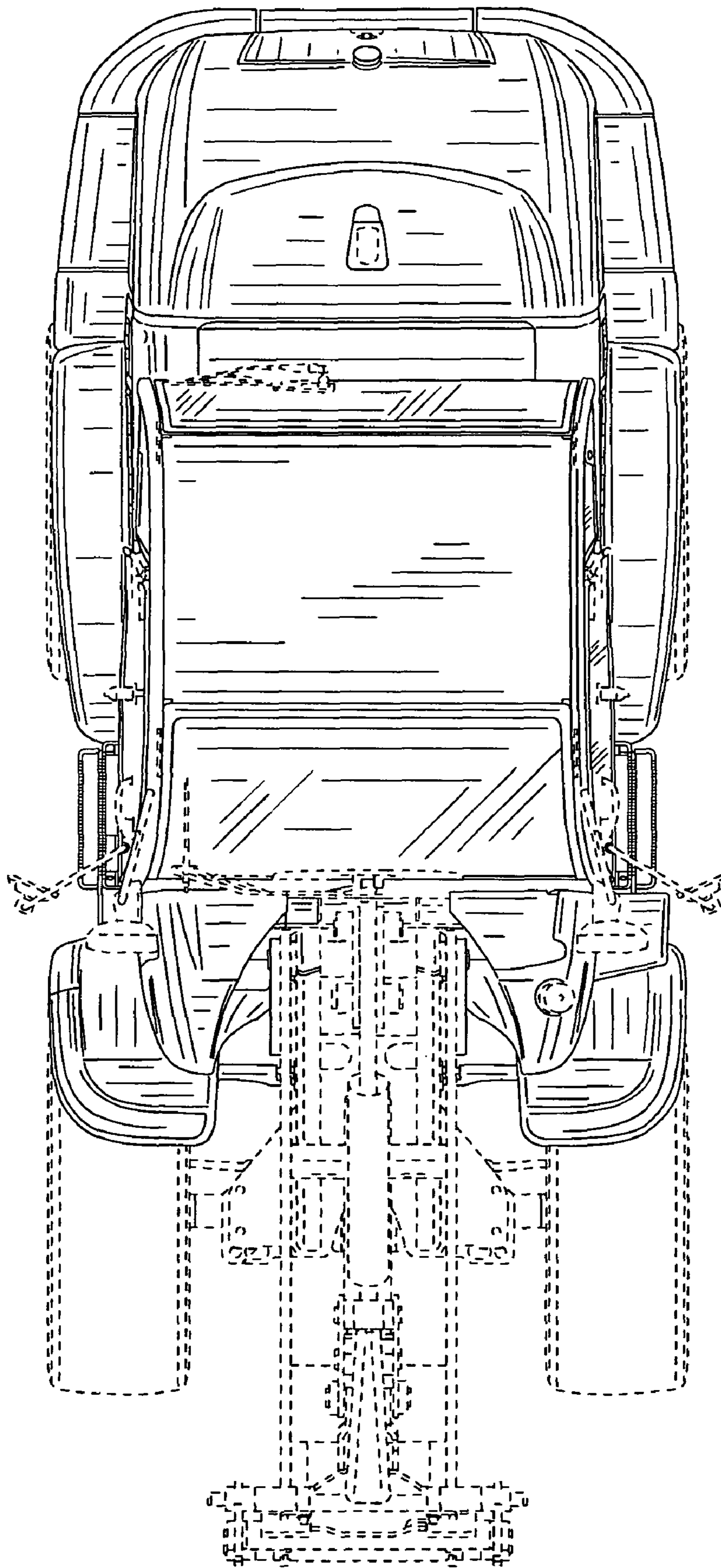

FIG. 6

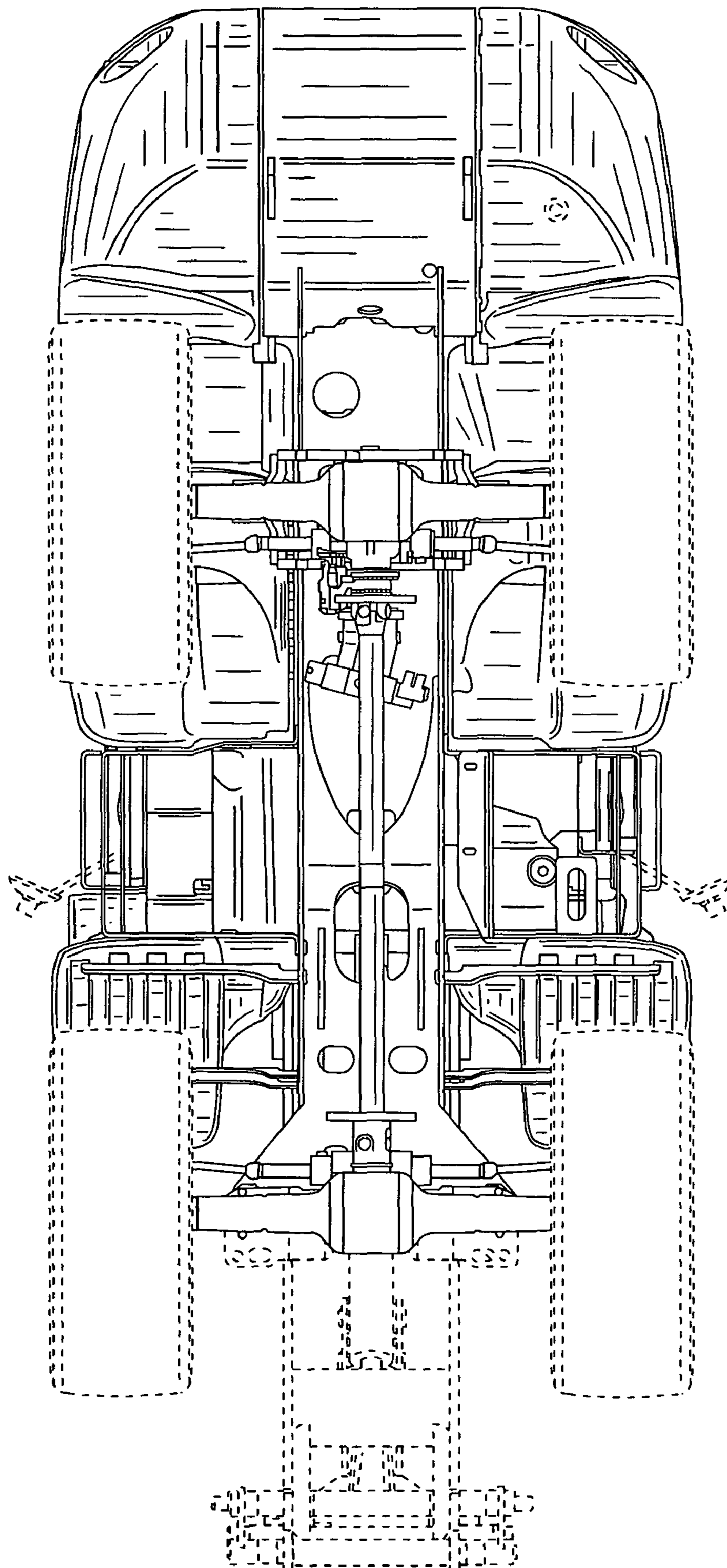

FIG. 7