



US00D634687S

(12) **United States Design Patent**  
**Vukel**

(10) **Patent No.:** **US D634,687 S**

(45) **Date of Patent:** **\*\* Mar. 22, 2011**

(54) **HITCH STEP**

(76) Inventor: **Ken Vukel**, Garfield, NJ (US)

(\*\*) Term: **14 Years**

(21) Appl. No.: **29/375,927**

(22) Filed: **Sep. 29, 2010**

(51) **LOC (9) Cl.** ..... **12-16**

(52) **U.S. Cl.** ..... **D12/203; D12/162**

(58) **Field of Classification Search** ..... D12/203,  
D12/162; 224/521; 182/90-92, 150; 280/163-165,  
280/770, 507; D25/68-69, 62; 293/117  
See application file for complete search history.

(56) **References Cited**

**U.S. PATENT DOCUMENTS**

5,829,774	A	*	11/1998	Klemp	.....	280/507
D444,754	S	*	7/2001	Storer	.....	D12/203
D463,345	S	*	9/2002	Cipolla	.....	D12/203
D494,914	S	*	8/2004	Elwell et al.	.....	D12/203
D495,646	S	*	9/2004	Elwell et al.	.....	D12/203
D505,901	S	*	6/2005	Wang	.....	D12/203
D511,319	S	*	11/2005	Wang	.....	D12/203
D513,217	S	*	12/2005	Daws et al.	.....	D12/203
D513,398	S	*	1/2006	Kozak et al.	.....	D12/203

D527,323	S	*	8/2006	Storer	.....	D12/203
D532,354	S	*	11/2006	Storer	.....	D12/203
D535,928	S	*	1/2007	Crandall	.....	D12/203

\* cited by examiner

*Primary Examiner* — Stacia Cadmus

(74) *Attorney, Agent, or Firm* — McGuireWoods LLP

(57) **CLAIM**

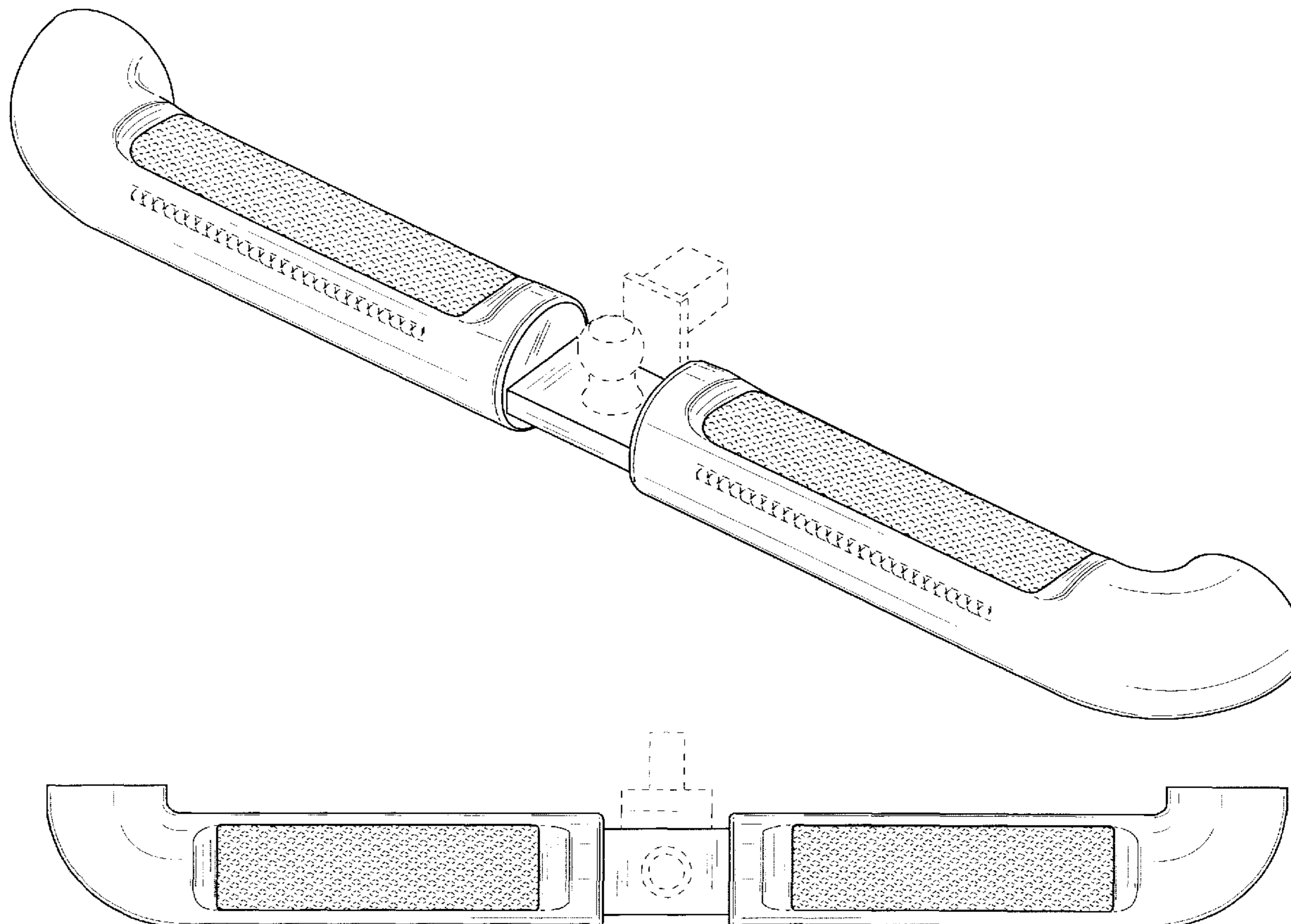
The ornamental design for a hitch step, as shown and described.

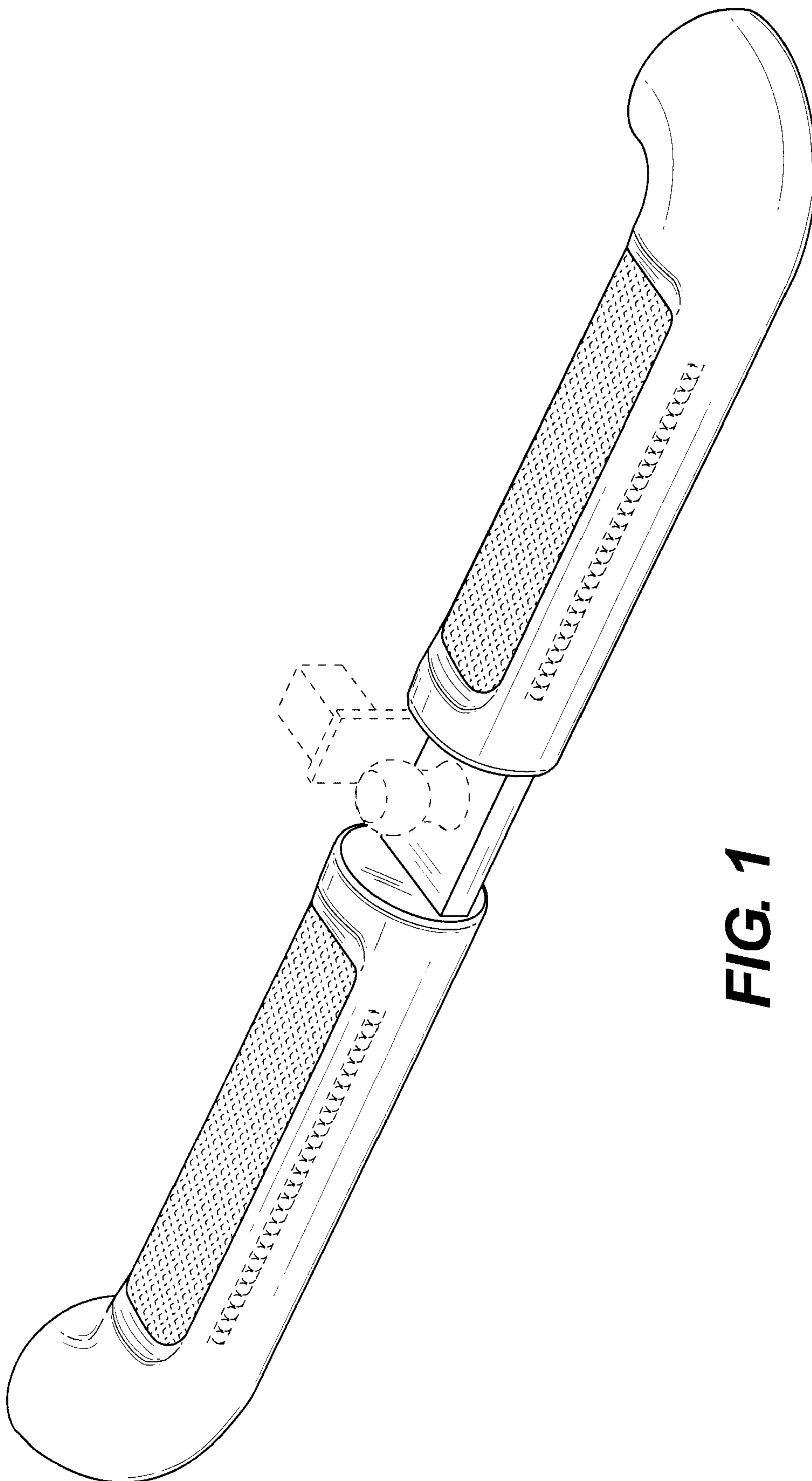
**DESCRIPTION**

FIG. 1 is a left front side perspective view of the hitch step; FIG. 2 is a front side view of the design embodiment shown in FIG. 1; FIG. 3 is a right side view of the design embodiment shown in FIG. 1; FIG. 4 is a top view of the design embodiment shown in FIG. 1; and, FIG. 5 is a bottom view of the design embodiment shown in FIG. 1.

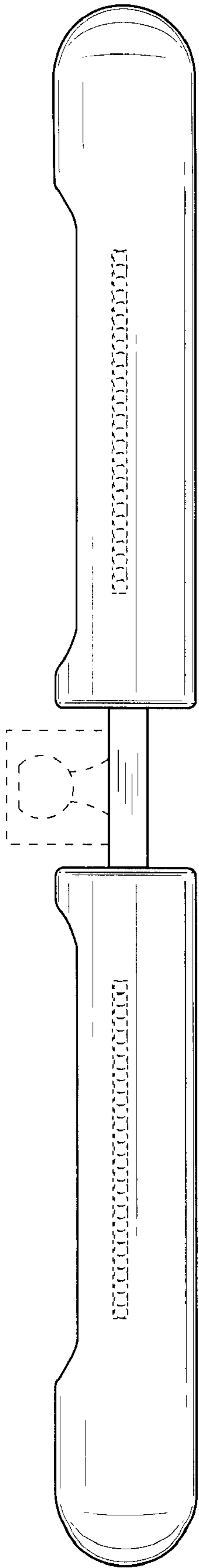
The broken line showing of the hitch apparatus is included for the purpose of illustrating environment and forms no part of the claimed design.

**1 Claim, 3 Drawing Sheets**

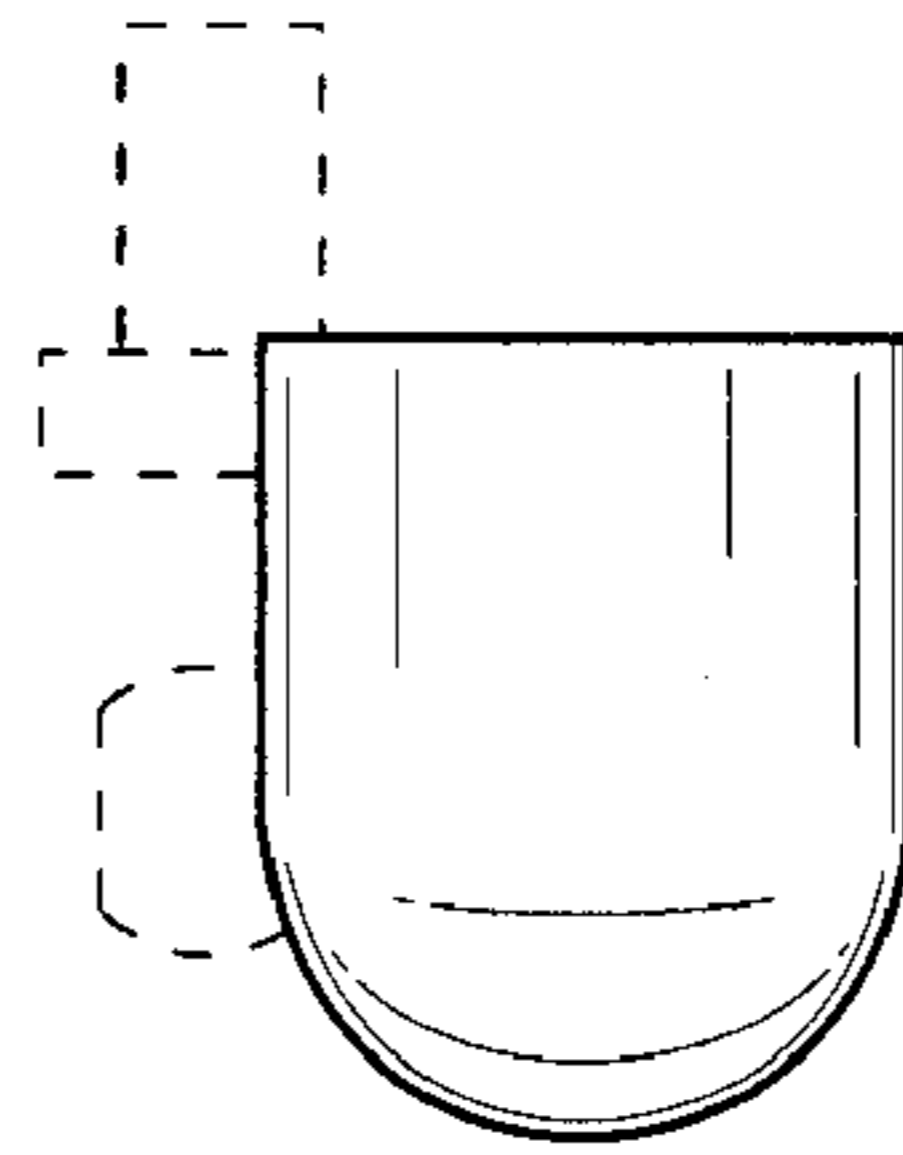




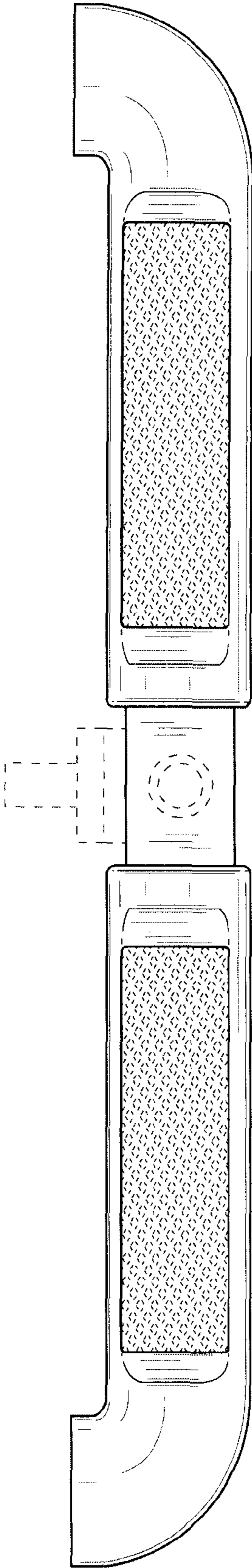
**FIG. 1**



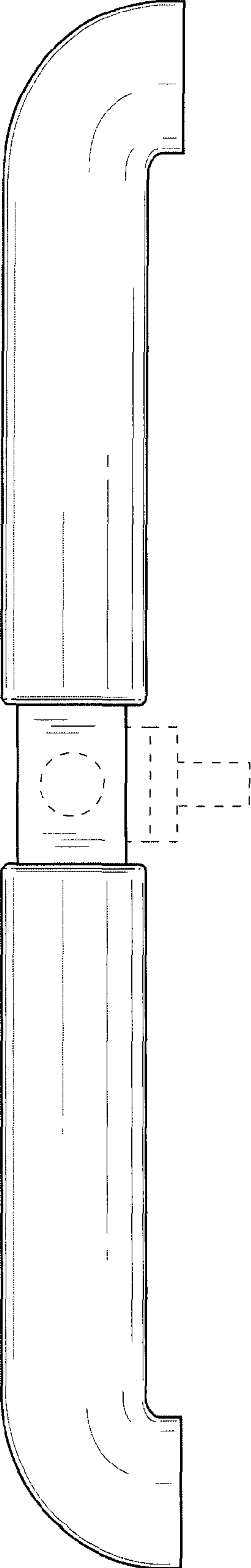
**FIG. 2**



**FIG. 3**



**FIG. 4**



**FIG. 5**