



US00D634686S

(12) **United States Design Patent**  
**Matei et al.**

(10) **Patent No.:** **US D634,686 S**  
(45) **Date of Patent:** **\*\* Mar. 22, 2011**

(54) **VEHICLE TAILGATE**

(56) **References Cited**

(75) Inventors: **Catalin Matei**, Redondo Beach, CA  
(US); **Glenn Earl Simmons**, Torrance,  
CA (US)

U.S. PATENT DOCUMENTS

D540,234 S *	4/2007	Fujimaki .....	D12/196
D558,658 S *	1/2008	Leclercq .....	D12/196
D583,738 S *	12/2008	Tonello .....	D12/196
D589,854 S *	4/2009	Suga et al. ....	D12/164
D608,701 S *	1/2010	Burki et al. ....	D12/164
D622,192 S *	8/2010	Yagi et al. ....	D12/164

(73) Assignee: **Honda Motor Co., Ltd.**, Tokyo (JP)

\* cited by examiner

(\*\*) Term: **14 Years**

*Primary Examiner* — Melody N Brown

(21) Appl. No.: **29/363,671**

(74) *Attorney, Agent, or Firm* — Plumsea Law Group, LLC;  
Mark E. Duell

(22) Filed: **Jun. 11, 2010**

(57) **CLAIM**

The ornamental design for a vehicle tailgate, as shown and described.

**Related U.S. Application Data**

**DESCRIPTION**

(63) Continuation-in-part of application No. 29/355,682,  
filed on Feb. 11, 2010.

The contents of concurrently filed application Ser. No.  
29/363,626 are also hereby incorporated by reference.

(51) **LOC (9) Cl.** ..... **12-16**

FIG. 1 is a perspective view of a vehicle tailgate showing my  
our design;

(52) **U.S. Cl.** ..... **D12/196; D12/164**

FIG. 2 is another perspective view thereof viewed from the  
opposite side;

(58) **Field of Classification Search** ..... D12/164,  
D12/196, 90-92, 86; D21/424, 433, 434;  
296/181.1, 181.5

FIG. 3 is a front elevational view thereof; and,  
FIG. 4 is a top plan view thereof.

The broken line showings of the center brake light and wind-  
shield wiper form no part of the claimed design.

See application file for complete search history.

**1 Claim, 3 Drawing Sheets**

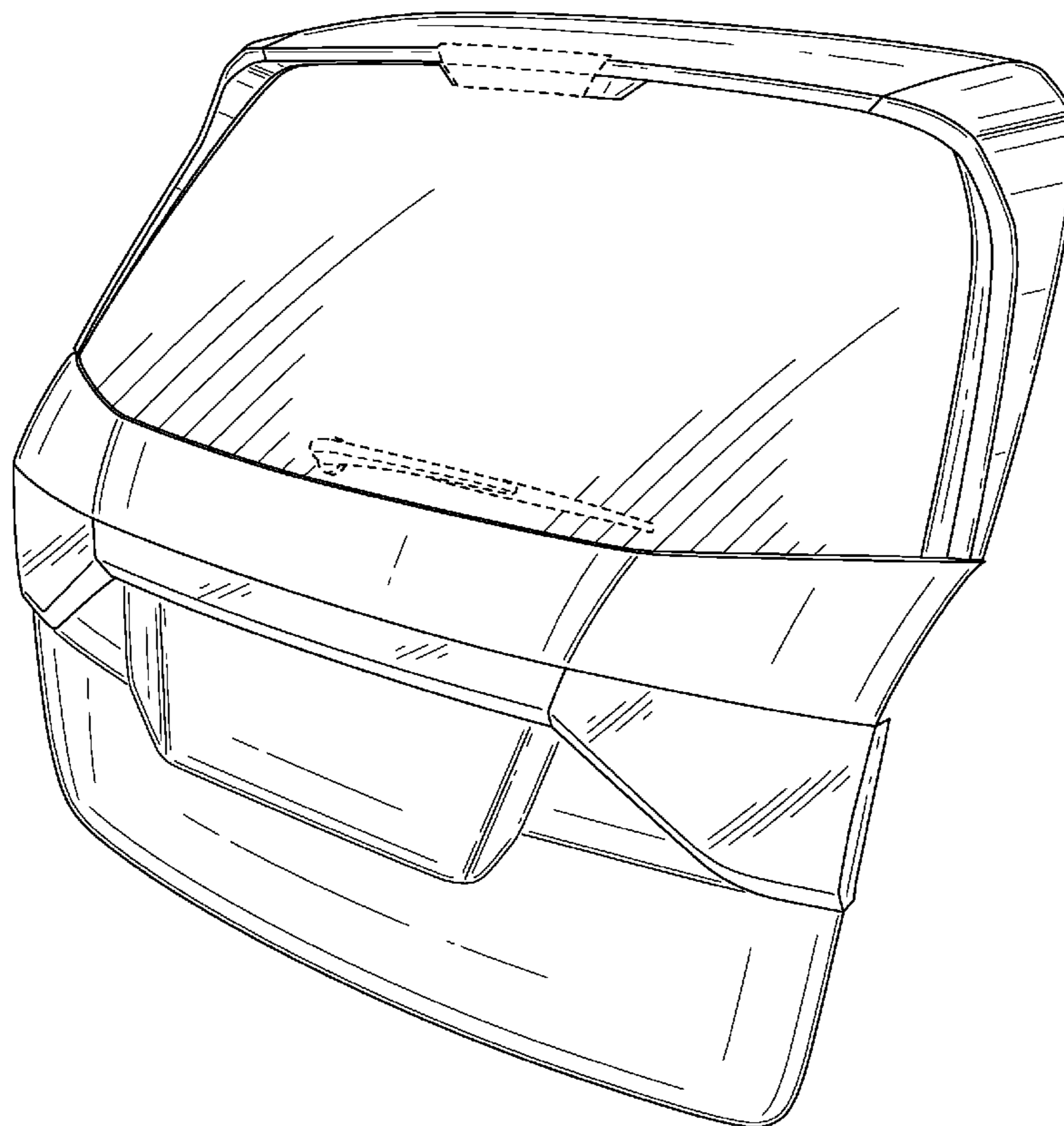

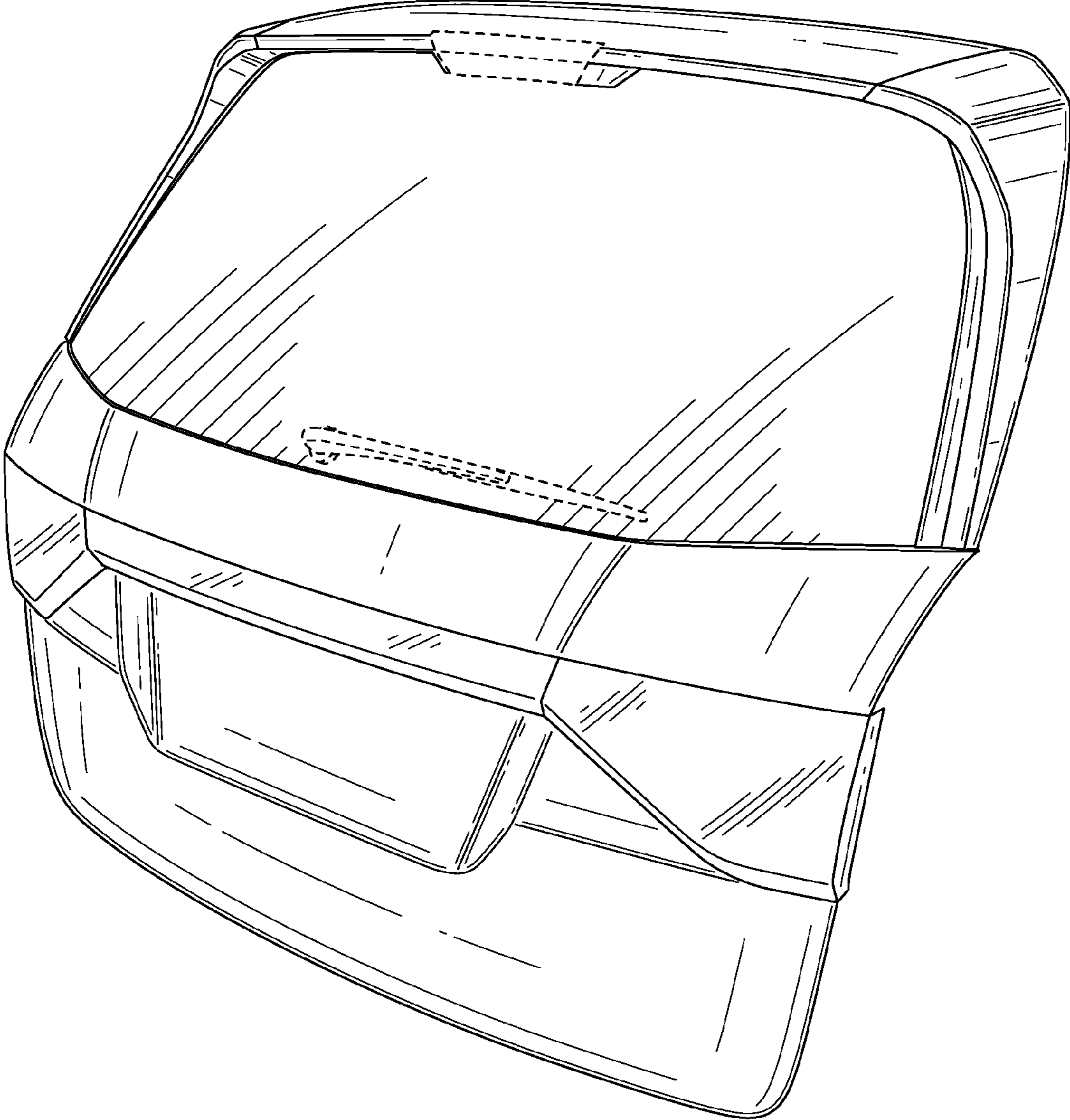

FIG. 1

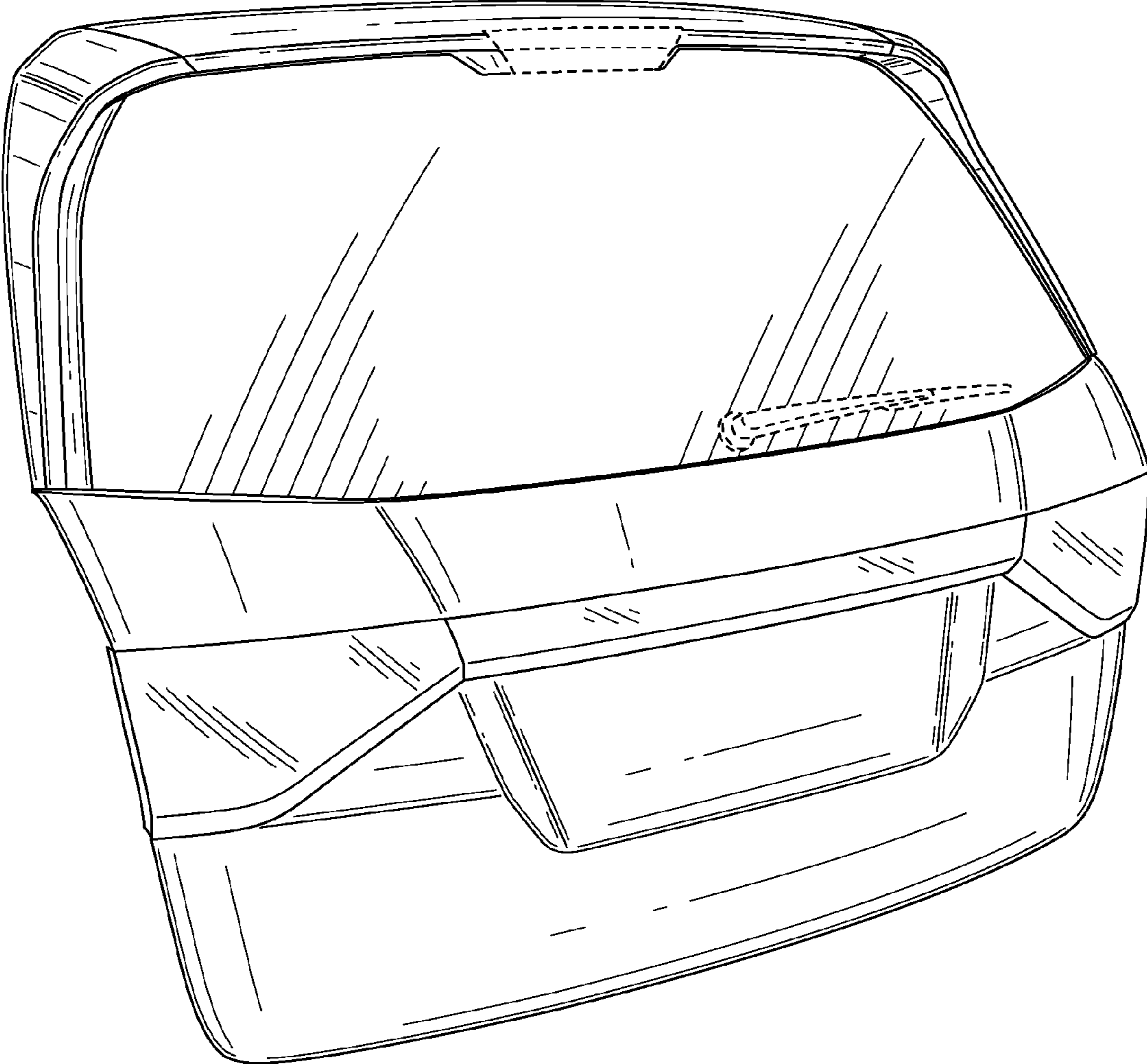

FIG. 2

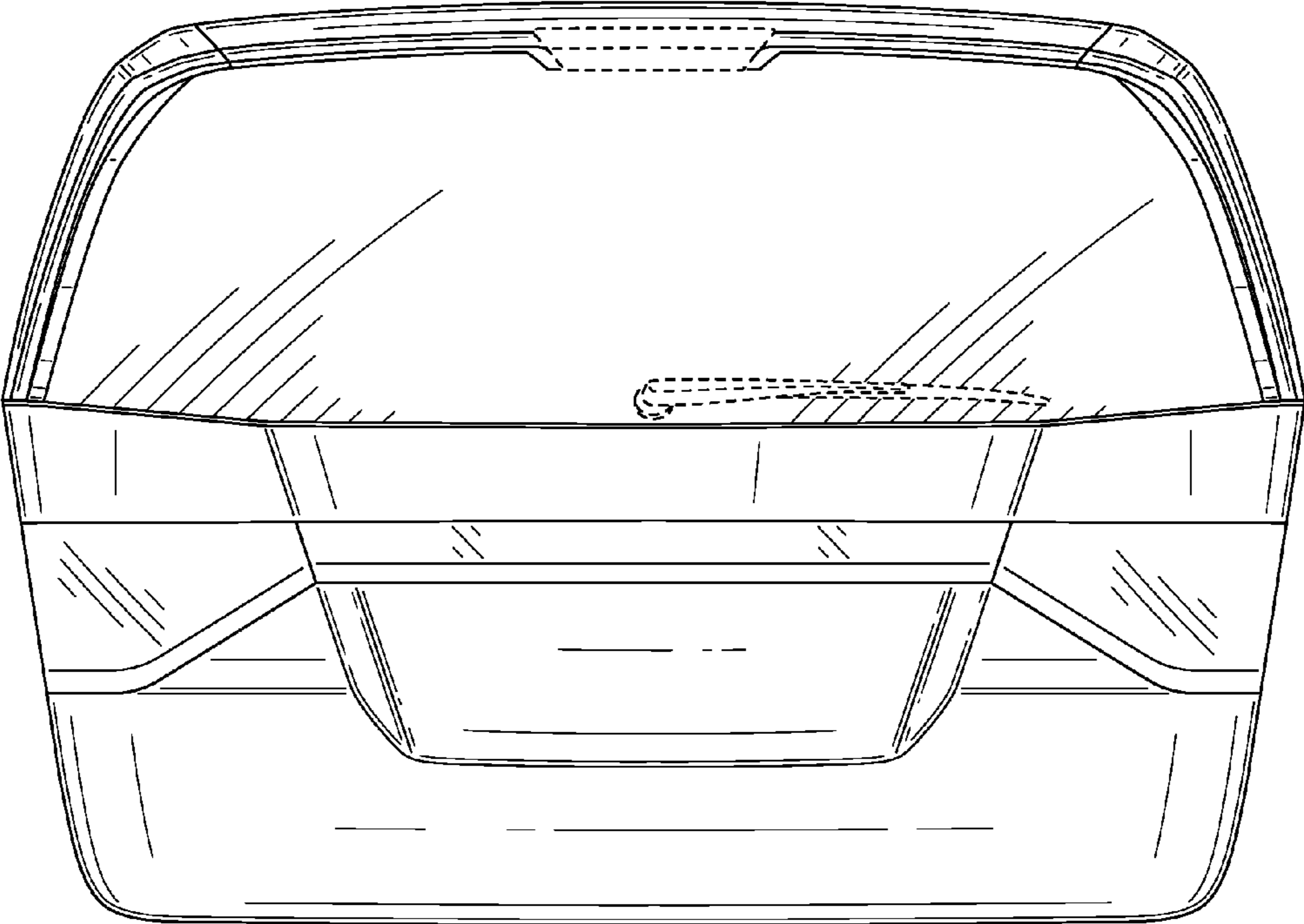

FIG. 3

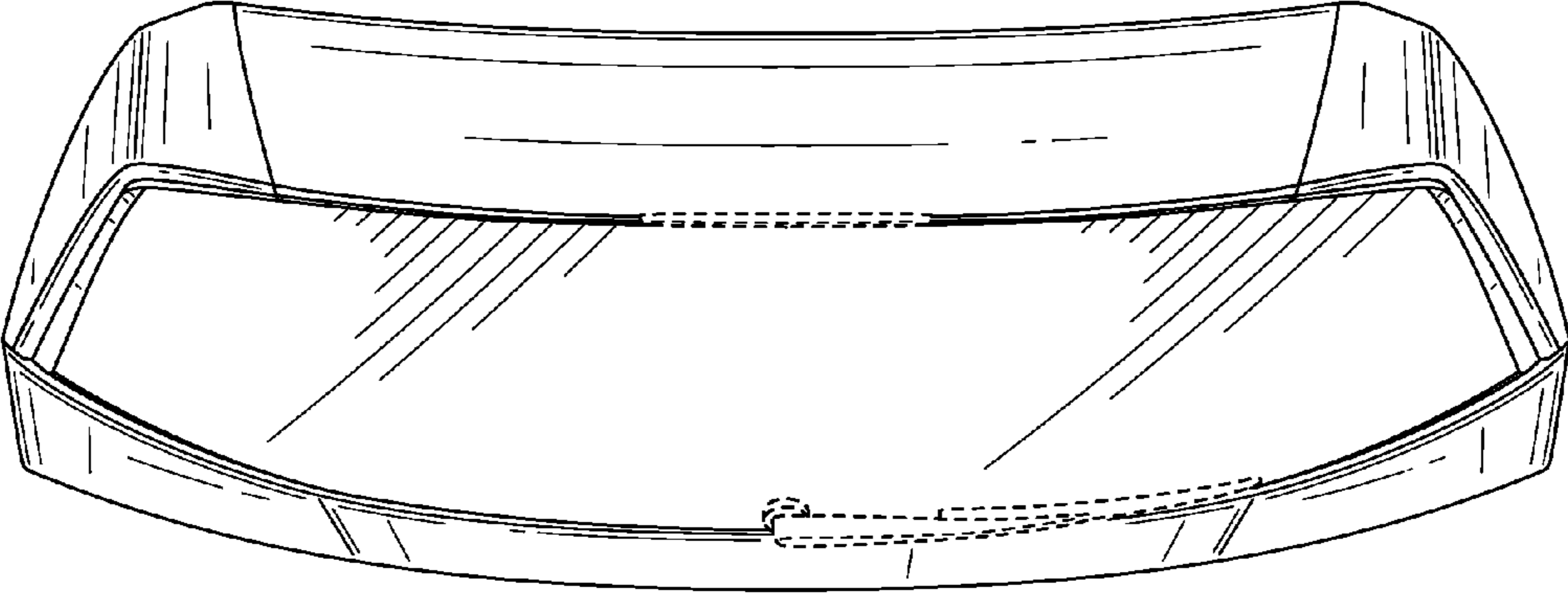

FIG. 4