



US00D634366S

(12) **United States Design Patent**
Squillante

(10) **Patent No.:** **US D634,366 S**
(45) **Date of Patent:** **** Mar. 15, 2011**

- (54) **ADVERTISING DISPLAY SIGN**
- (76) Inventor: **Phillip Allan Squillante**, Indian River, FL (US)
- (**) Term: **14 Years**
- (21) Appl. No.: **29/362,450**
- (22) Filed: **May 25, 2010**
- (51) **LOC (9) Cl.** **20-03**
- (52) **U.S. Cl.** **D20/10**
- (58) **Field of Classification Search** D20/10, D20/19, 21, 29, 39, 41-43, 99; 40/446, 473, 40/489, 538, 541, 558, 584, 588-593, 617, 40/618, 643; D10/104, 109; 362/812
See application file for complete search history.

- D350,369 S 9/1994 Shafley
- D386,208 S 11/1997 Caulk
- D386,214 S * 11/1997 Belokin et al. D20/42
- D433,454 S 11/2000 Elmer
- D447,774 S 9/2001 Elmer
- D476,690 S 7/2003 Elmer
- D480,432 S 10/2003 Newman
- D515,630 S * 2/2006 Macmillan D20/19
- D526,361 S 8/2006 Yasuoka

* cited by examiner

Primary Examiner — Janice E Seeger
Assistant Examiner — Mary Ann Calabrese
(74) *Attorney, Agent, or Firm* — QuickPatents, Inc.; Kevin Prince

(57) **CLAIM**
What is claimed is the ornamental design for a advertising display sign, as shown and described.

(56) **References Cited**

U.S. PATENT DOCUMENTS

- 2,077,585 A * 4/1937 Rivers 40/592
- 2,960,786 A * 11/1960 Wagner 40/592
- 3,135,063 A * 6/1964 Ricks 40/473
- D204,727 S 5/1966 Diehl
- 3,254,434 A * 6/1966 Gintoft 40/592
- 3,440,748 A * 4/1969 Hackley 40/592
- D216,938 S * 3/1970 Nestegard D20/43
- D240,469 S * 7/1976 Bissell D20/10
- 4,392,316 A * 7/1983 Thomas 40/617
- 4,667,428 A * 5/1987 Elmer 40/592
- D290,620 S 6/1987 Elmer
- D290,621 S 6/1987 Ossvik
- 4,671,004 A * 6/1987 Berg 40/592
- 4,787,163 A 11/1988 Berg
- 4,991,335 A * 2/1991 Krautsack 40/617
- D327,333 S 6/1992 Elmer

DESCRIPTION

FIG. 1 is a perspective view of a advertising display sign, showing the new design in use;
FIG. 2 is a front elevational view thereof;
FIG. 3 is a rear elevational view thereof;
FIG. 4 is a left-side elevational view thereof;
FIG. 5 is a right-side elevational view thereof;
FIG. 6 is a top plan view thereof; and,
FIG. 7 is a bottom plan view thereof.
The broken lines showing a roof of a car in FIG. 1 and the word taxi are included for the purpose of illustrating the invention in use, and form no part of the claimed design.

1 Claim, 3 Drawing Sheets

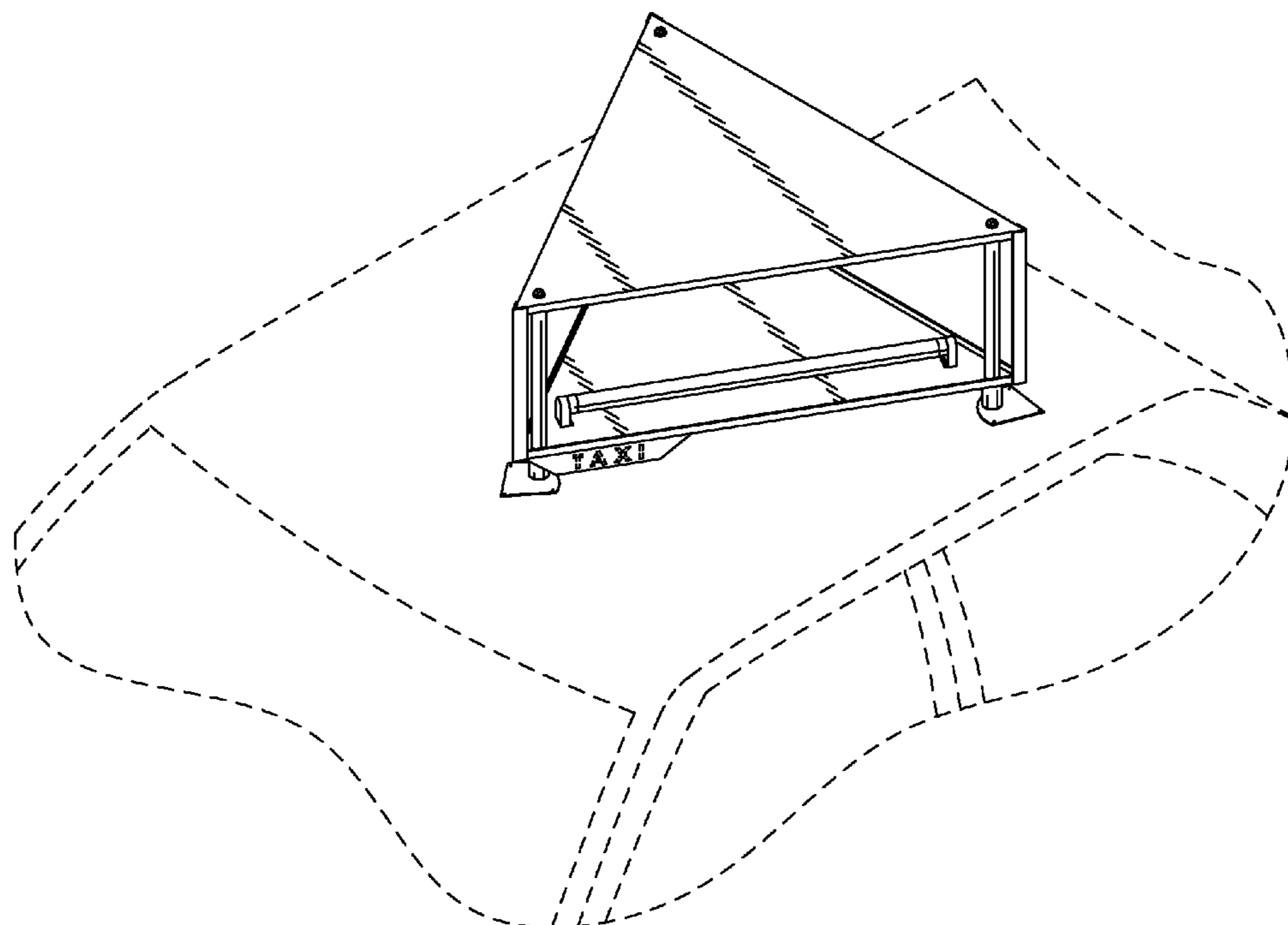

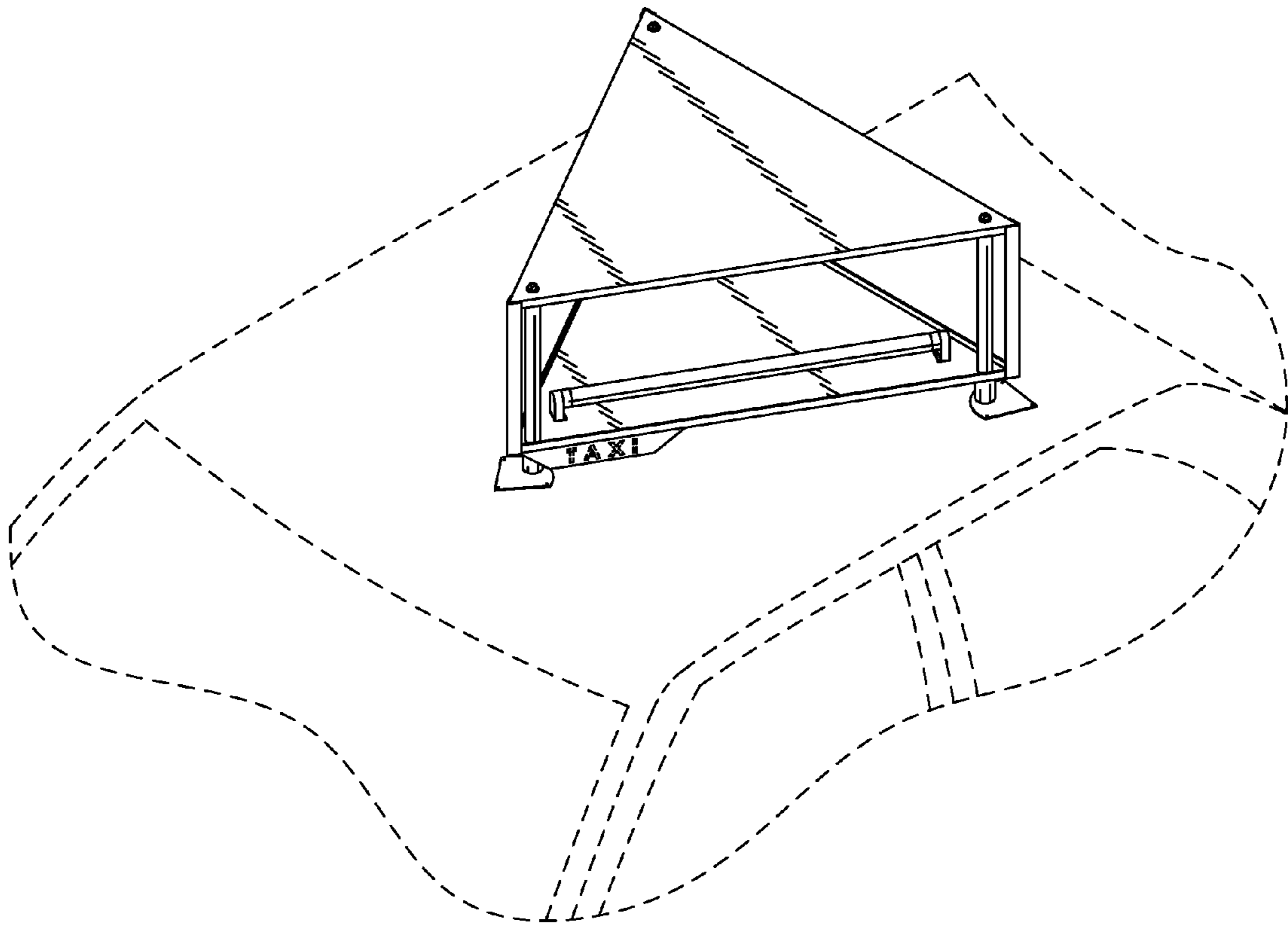

FIG. 1

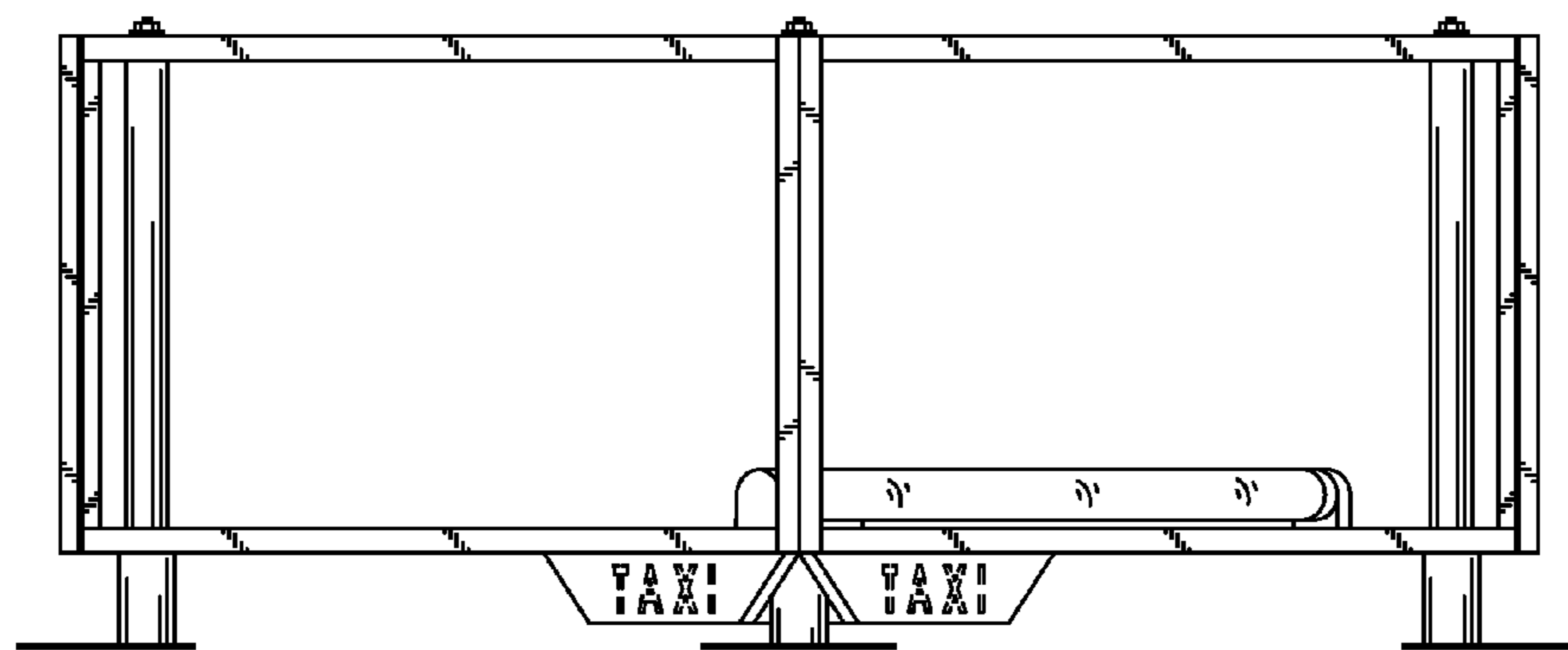

FIG. 2

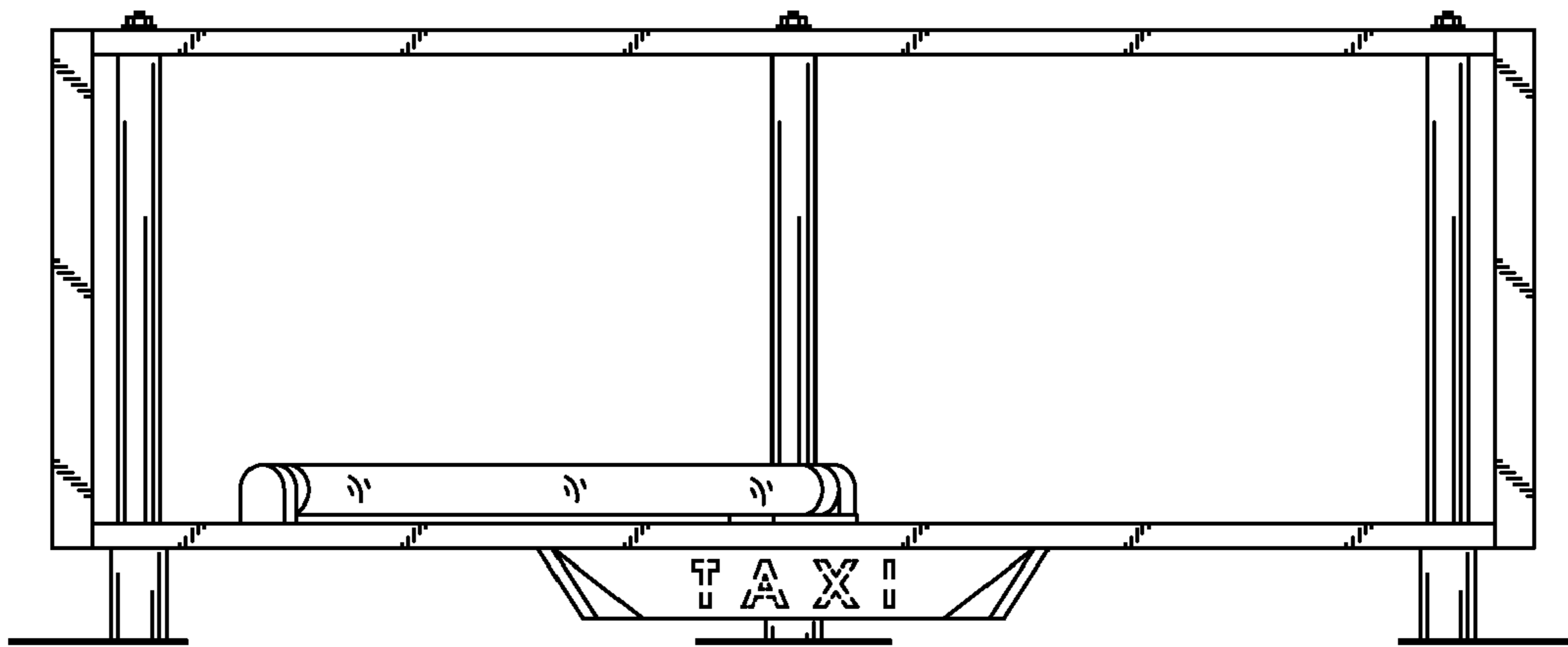

FIG. 3

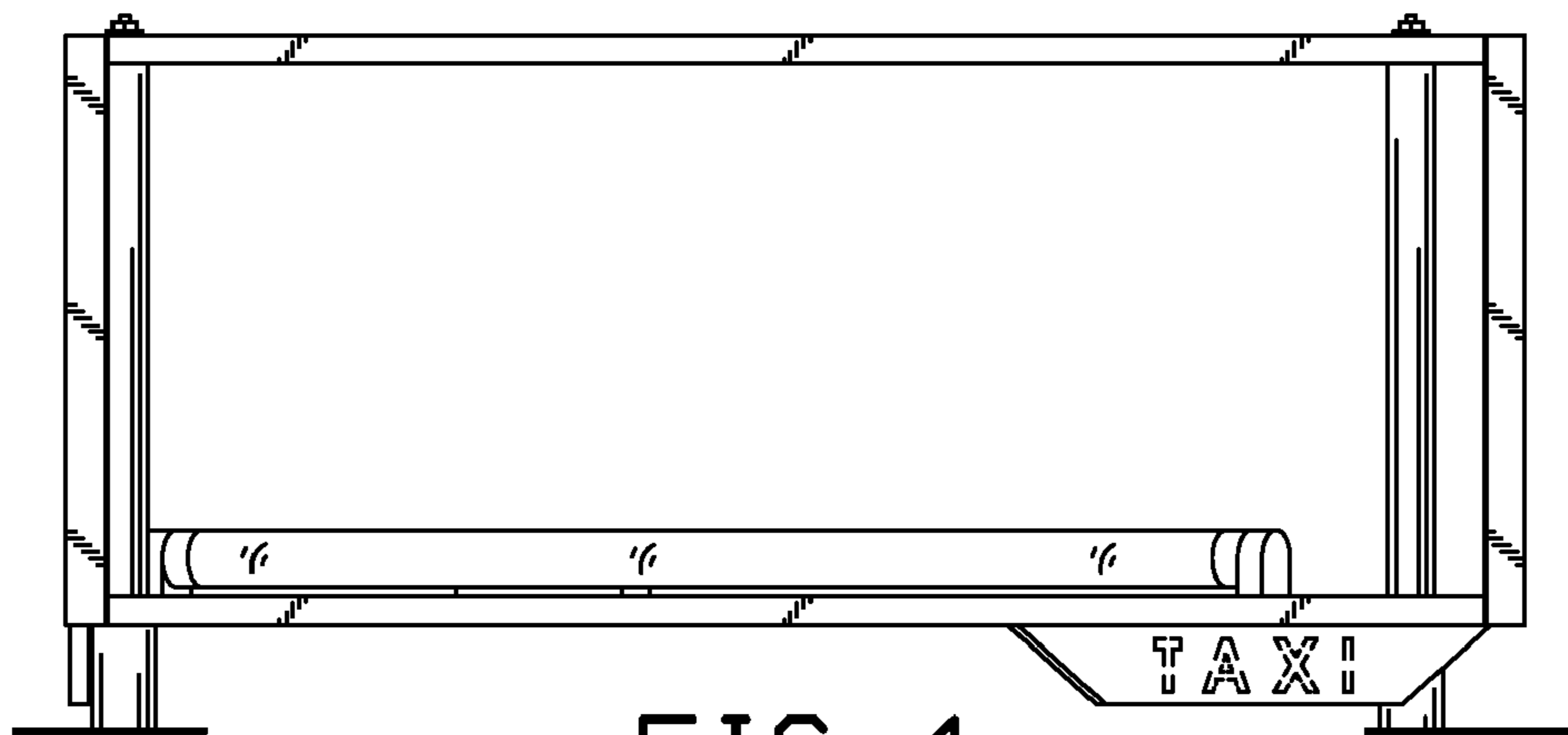

FIG. 4

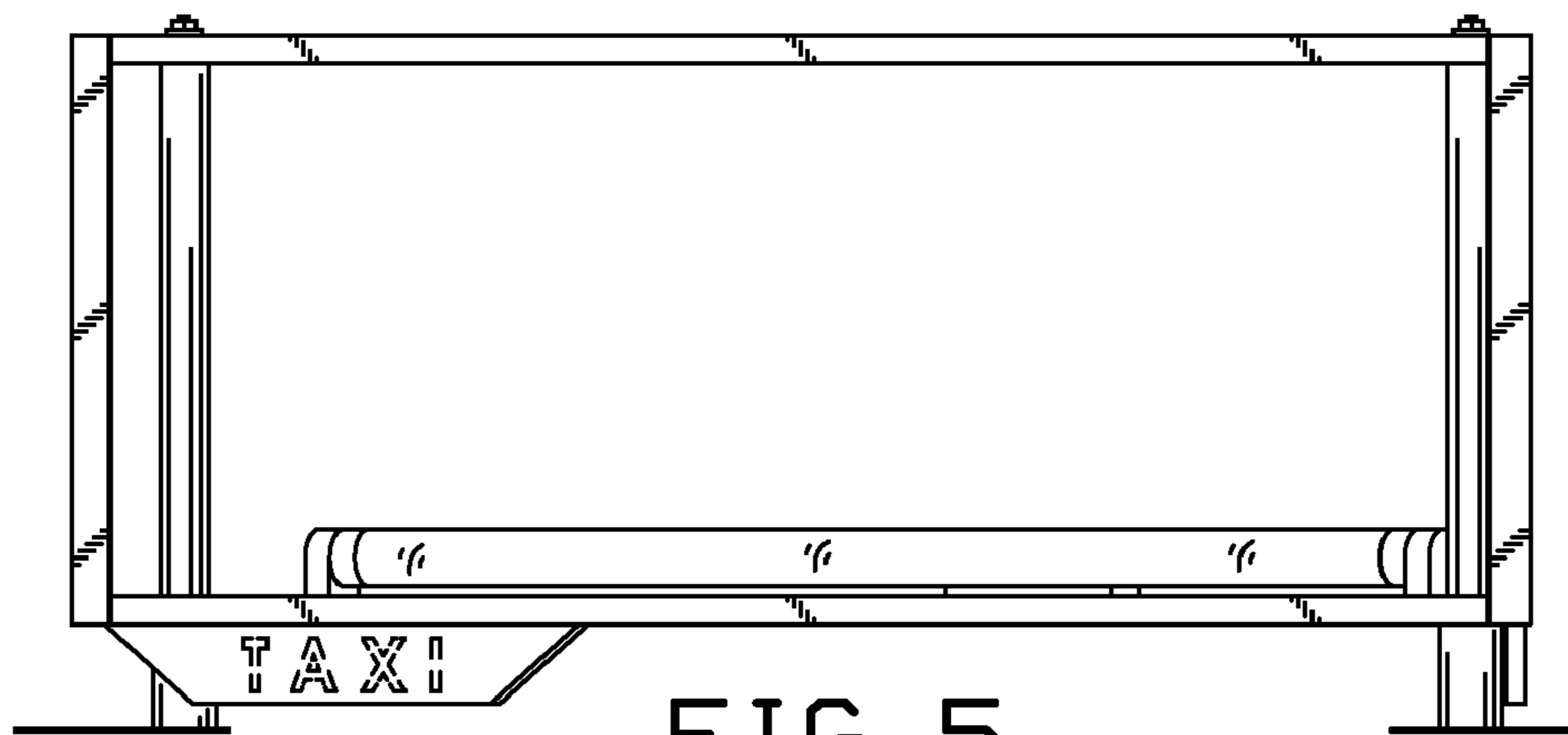

FIG. 5

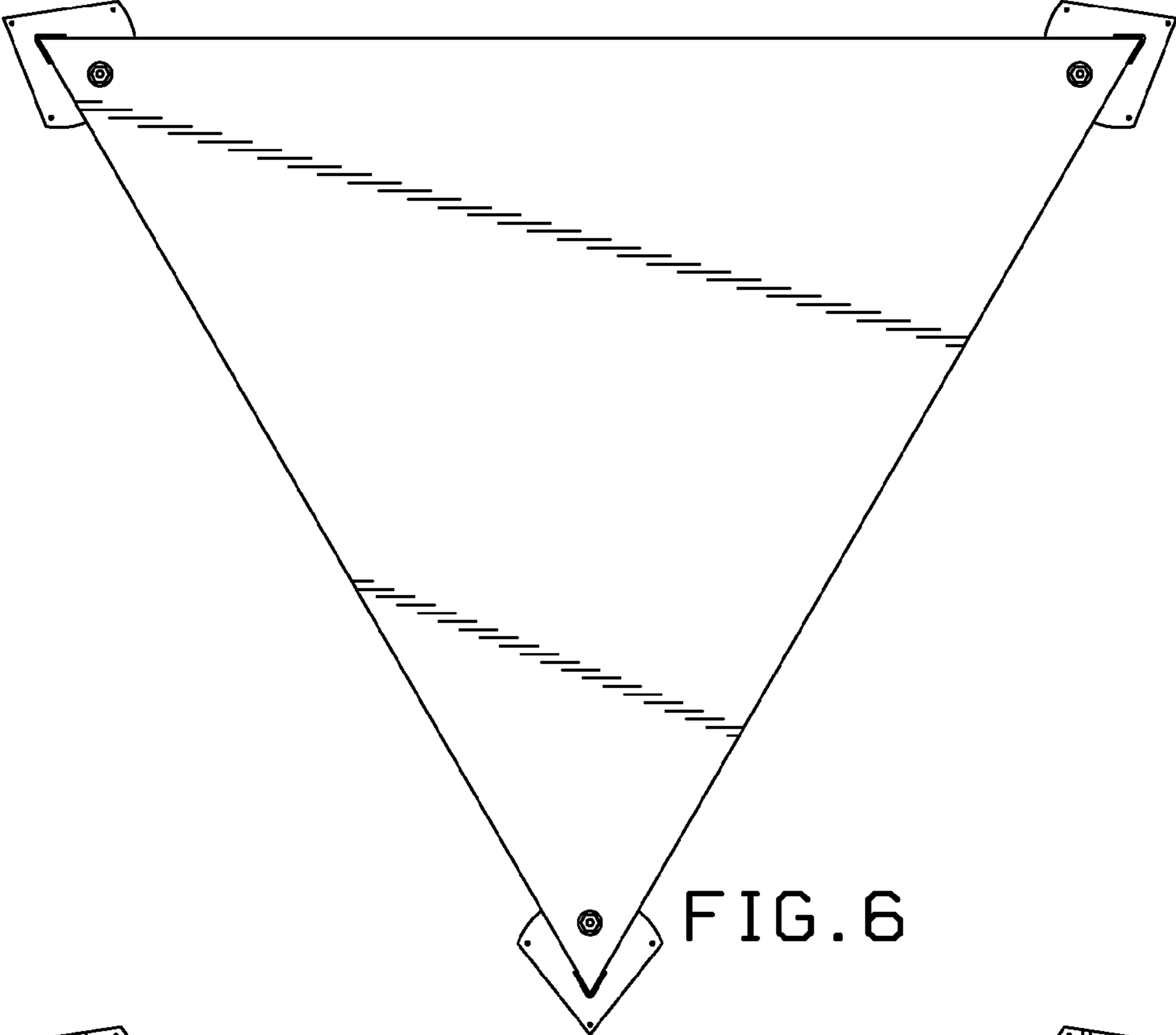

FIG. 6

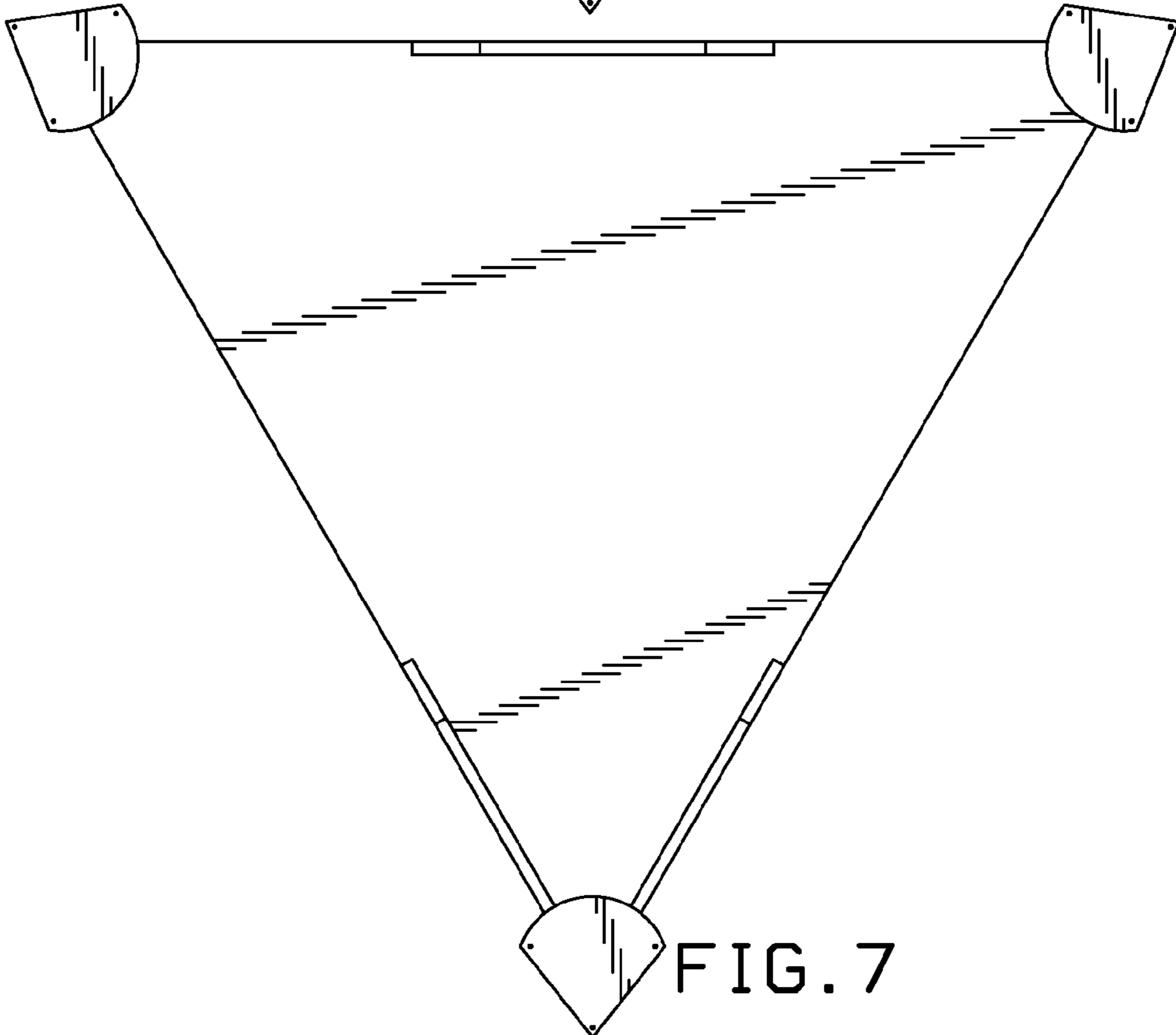

FIG. 7