



US00D634243S

(12) **United States Design Patent**
Frei et al.

(10) **Patent No.:** **US D634,243 S**
(45) **Date of Patent:** **** Mar. 15, 2011**

(54) **VEHICLE, TOY, AND/OR REPLICAS THEREOF**

Primary Examiner — Melody N Brown
(74) *Attorney, Agent, or Firm* — Crowell & Moring LLP

(75) Inventors: **Michael Frei**, Sindelfingen (DE); **Klaus Frenzel**, Winnenden (DE); **Hans-Dieter Futschik**, Gechingen (DE); **Hubert Lee**, Irvine, CA (US); **Robert Lesnik**, Leonberg (DE); **Gorden Wagener**, Stuttgart (DE)

(57) **CLAIM**
The ornamental design for a vehicle, toy, and/or replicas thereof, as shown and described.

(73) Assignee: **Daimler AG**, Stuttgart (DE)

DESCRIPTION

(**) Term: **14 Years**

(21) Appl. No.: **29/371,036**

(22) Filed: **Sep. 23, 2010**

(30) **Foreign Application Priority Data**

Mar. 24, 2010 (EM) 001203939-0001

(51) **LOC (9) Cl.** **12-08**

(52) **U.S. Cl.** **D12/91**

(58) **Field of Classification Search** D12/86,
D12/90-92, 88; D21/424, 433, 434; 296/181.1,
296/181.5

See application file for complete search history.

(56) **References Cited**

U.S. PATENT DOCUMENTS

D499,358 S	12/2004	Pfeiffer et al.	
D506,706 S *	6/2005	Pfeiffer et al.	D12/91
D599,704 S *	9/2009	Frenzel et al.	D12/91
D600,172 S *	9/2009	Frenzel et al.	D12/164
D601,924 S *	10/2009	Bauer et al.	D12/91
D612,777 S *	3/2010	Bauer et al.	D12/164
D615,464 S *	5/2010	Frei et al.	D12/164
D617,682 S *	6/2010	Frei et al.	D12/91

FOREIGN PATENT DOCUMENTS

DE 402008001752.8 4/2008

* cited by examiner

This application contains subject matter related to the following co-pending U.S. design patent applications: application Ser. No. 29/371,037, filed herewith and entitled "Rear Portion of a Vehicle, Toy, and/or Replicas Thereof"; application Ser. No. 29/371,038, filed herewith and entitled "Vehicle, Toy, and/or Replicas Thereof"; application Ser. No. 29/371,034, filed herewith and entitled "Rear Portion of a Vehicle, Toy, and/or Replicas thereof"; application Ser. No. 29/371,035, filed herewith and entitled "Rear Portion of a Vehicle, Toy, and/or Replicas Thereof"; application Ser. No. 29/309,774, filed Oct. 7, 2008; application Ser. No. 29/309,776, filed Oct. 7, 2008; application Ser. No. 29/311,619, filed May 1, 2009; application Ser. No. 29/311,620, filed May 1, 2009; and application Ser. No. 29/311,621, filed May 1, 2009. FIG. 1 is a left, front perspective view of a vehicle, toy, and/or replicas thereof according to our design, the right, front perspective view being mirror symmetrical; FIG. 2 is a left, rear perspective view thereof, the right, rear perspective view being mirror symmetrical; FIG. 3 is a left side view thereof; FIG. 4 is a right side view thereof; FIG. 5 is a front view thereof; FIG. 6 is a rear view thereof; and, FIG. 7 is a top view thereof. The broken lines are for illustrative purposes only and form no part of the claimed design.

1 Claim, 6 Drawing Sheets

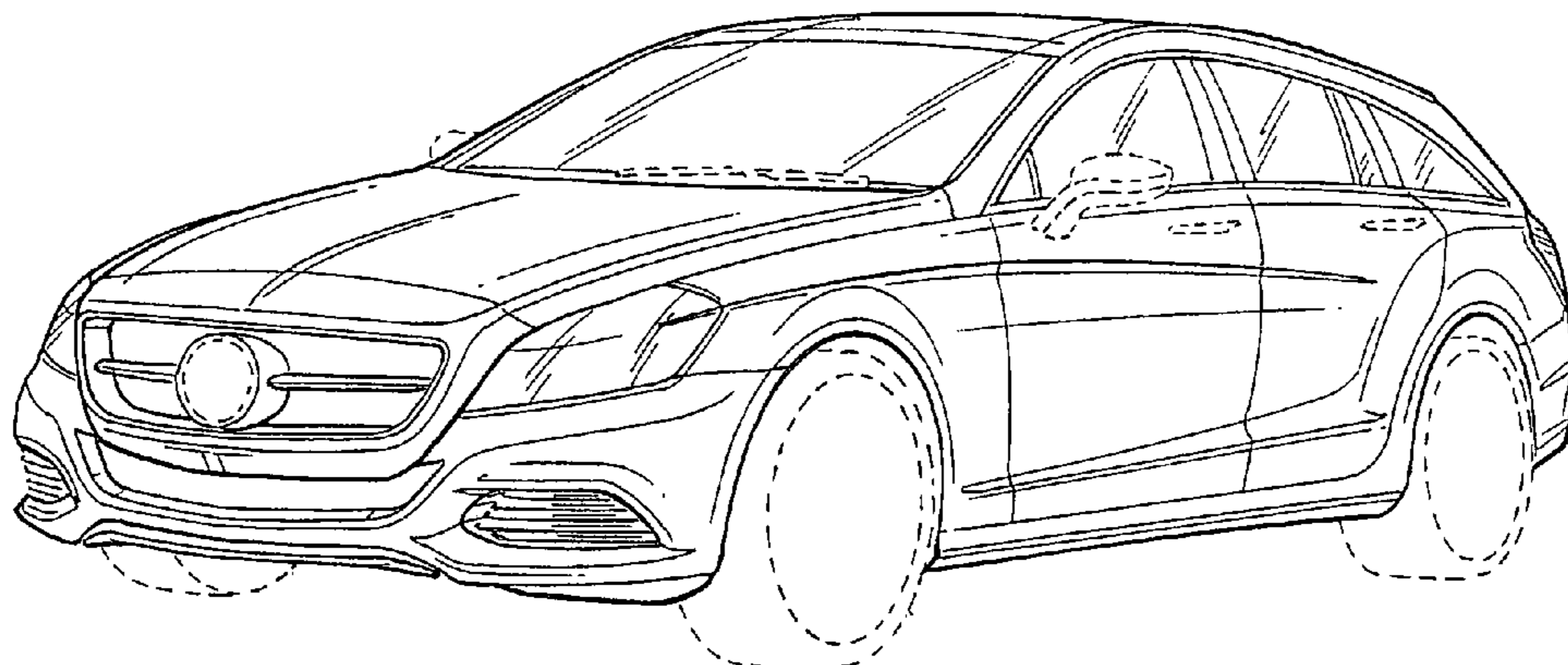

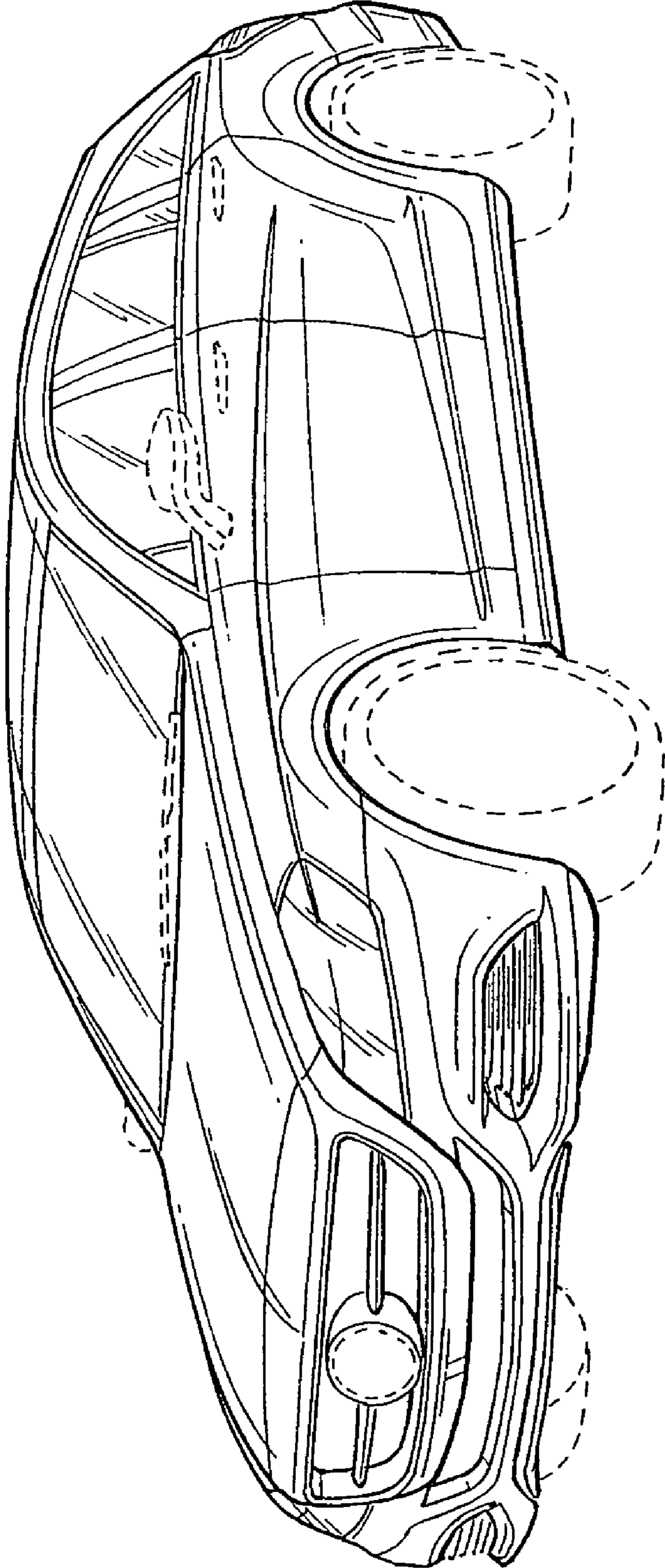

FIG. 1

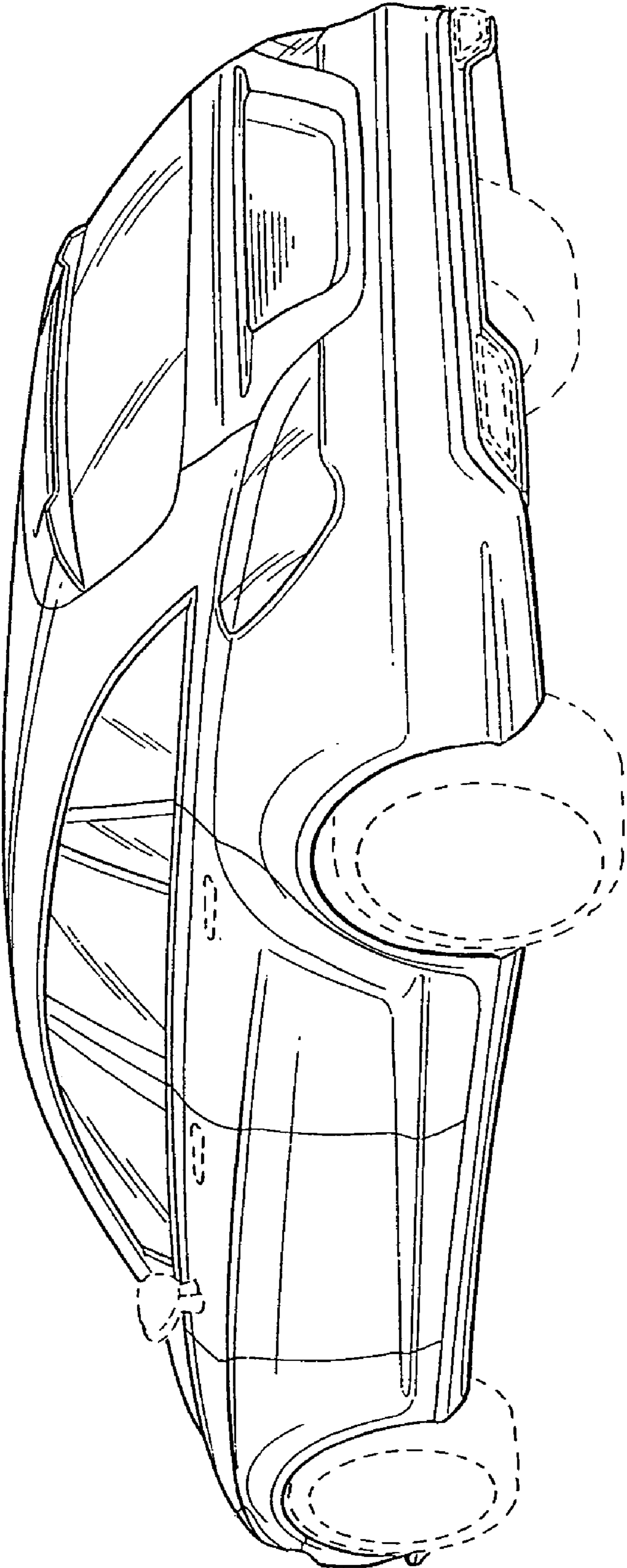

FIG. 2

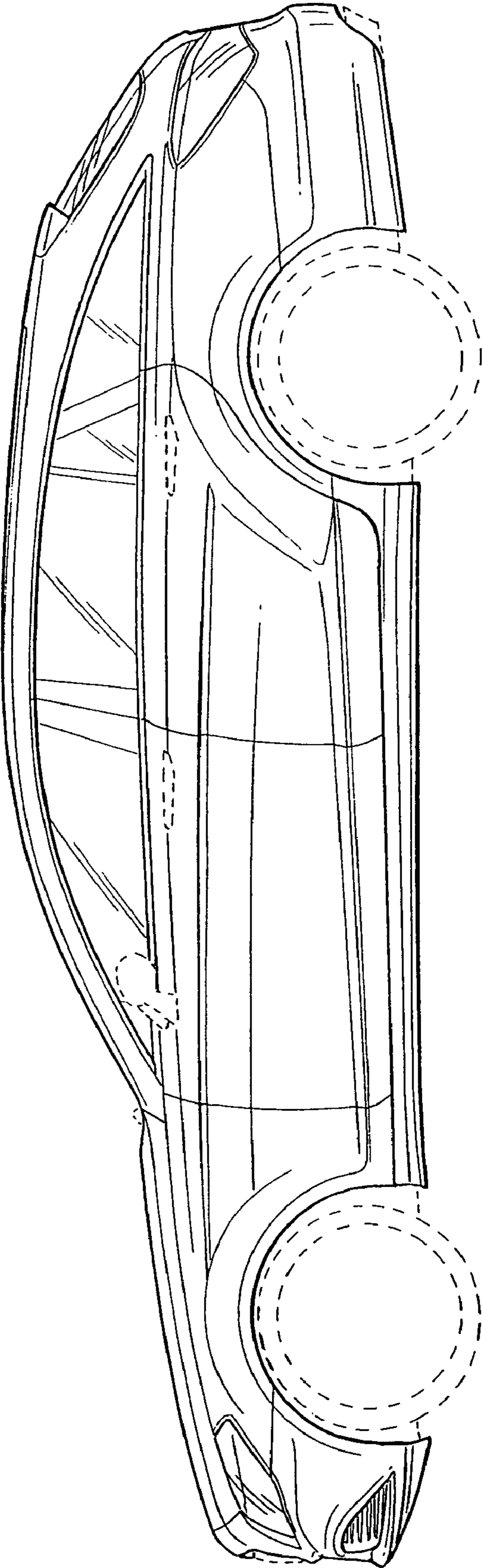

FIG. 3

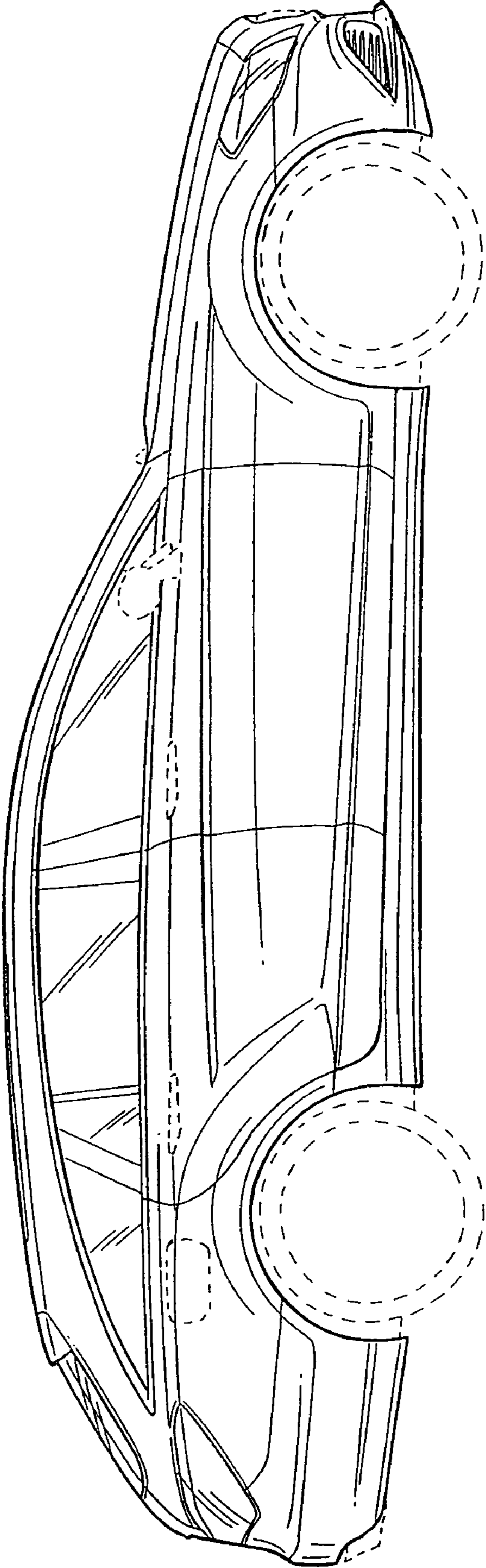

FIG. 4

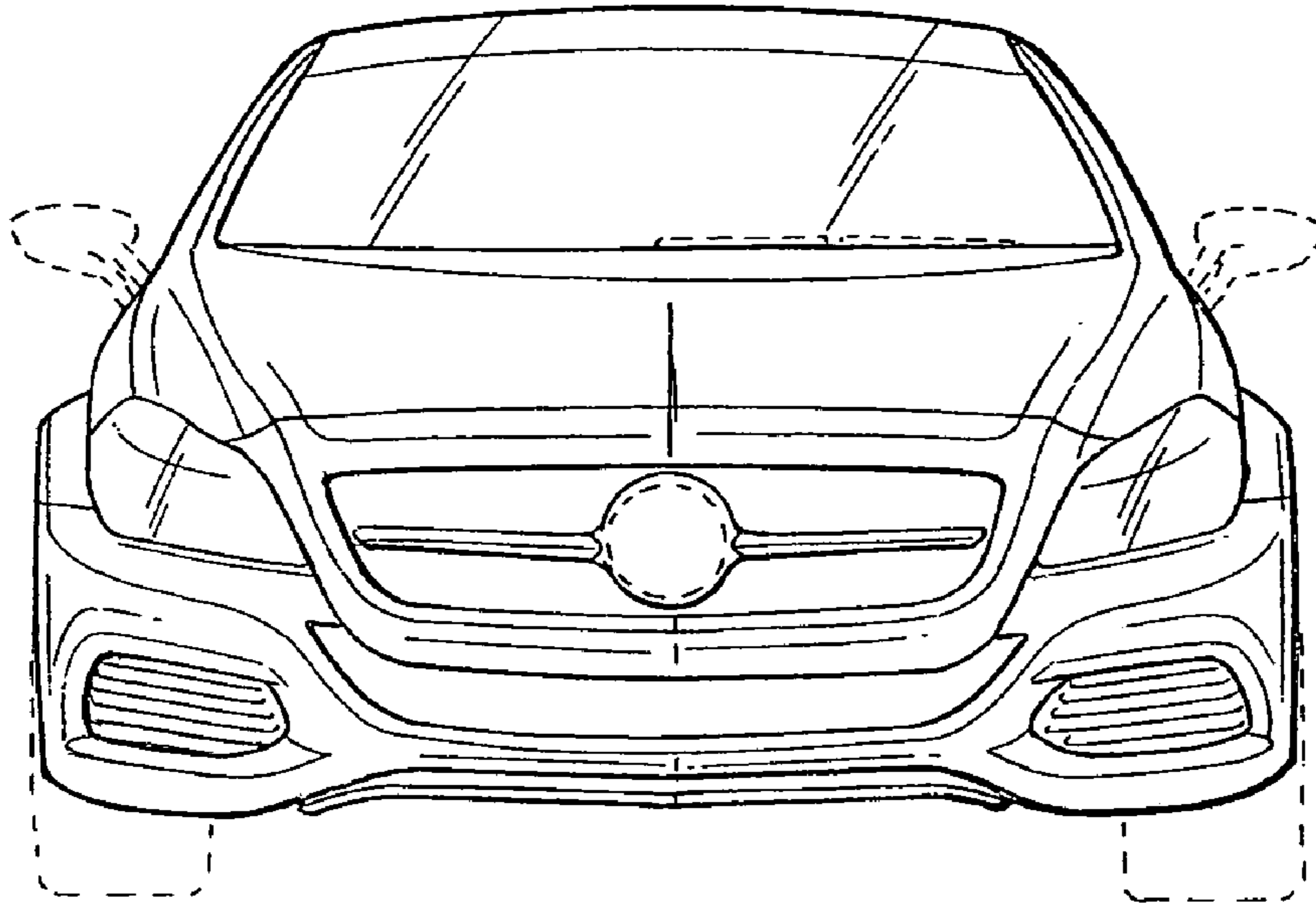

FIG. 5

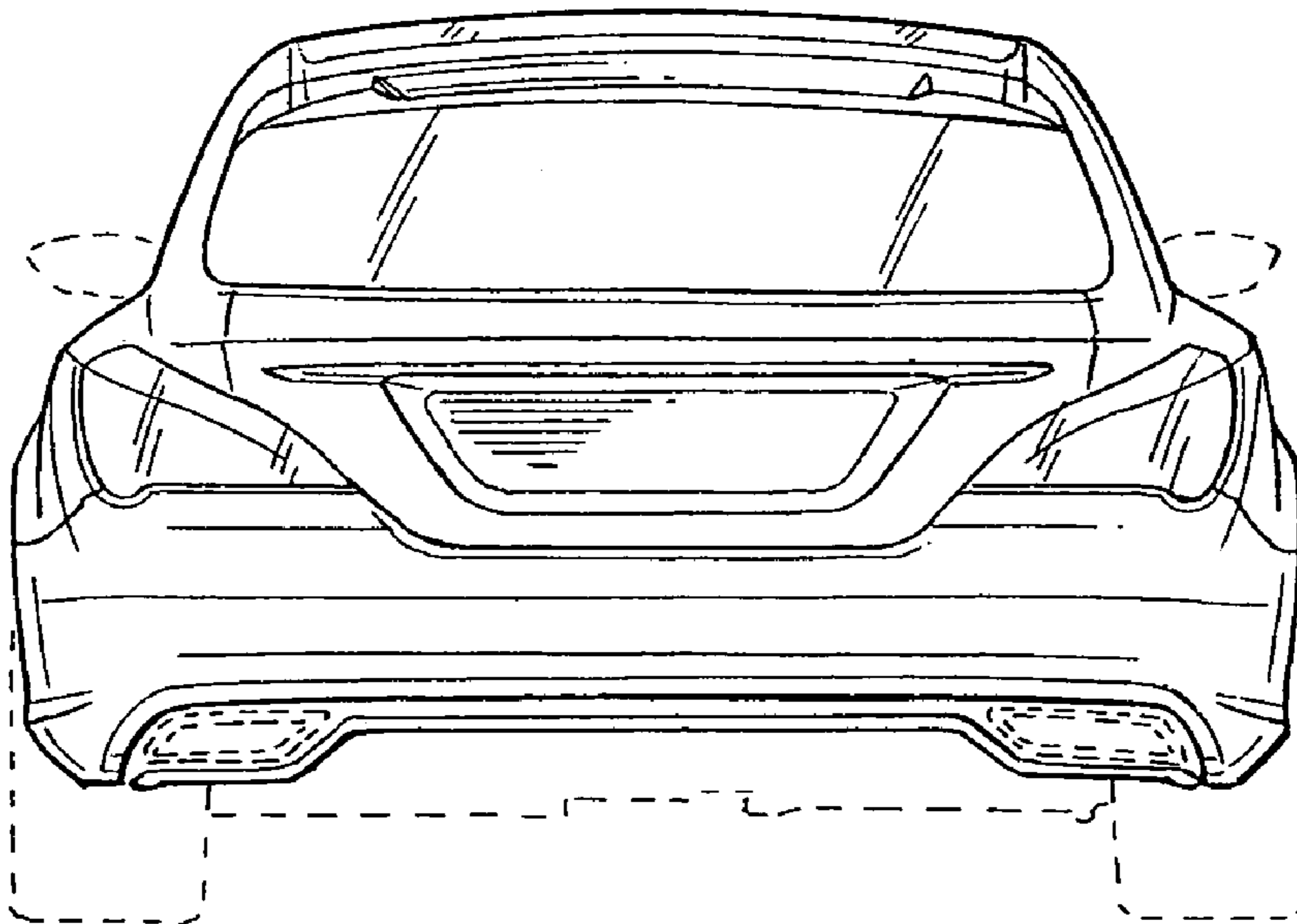

FIG. 6

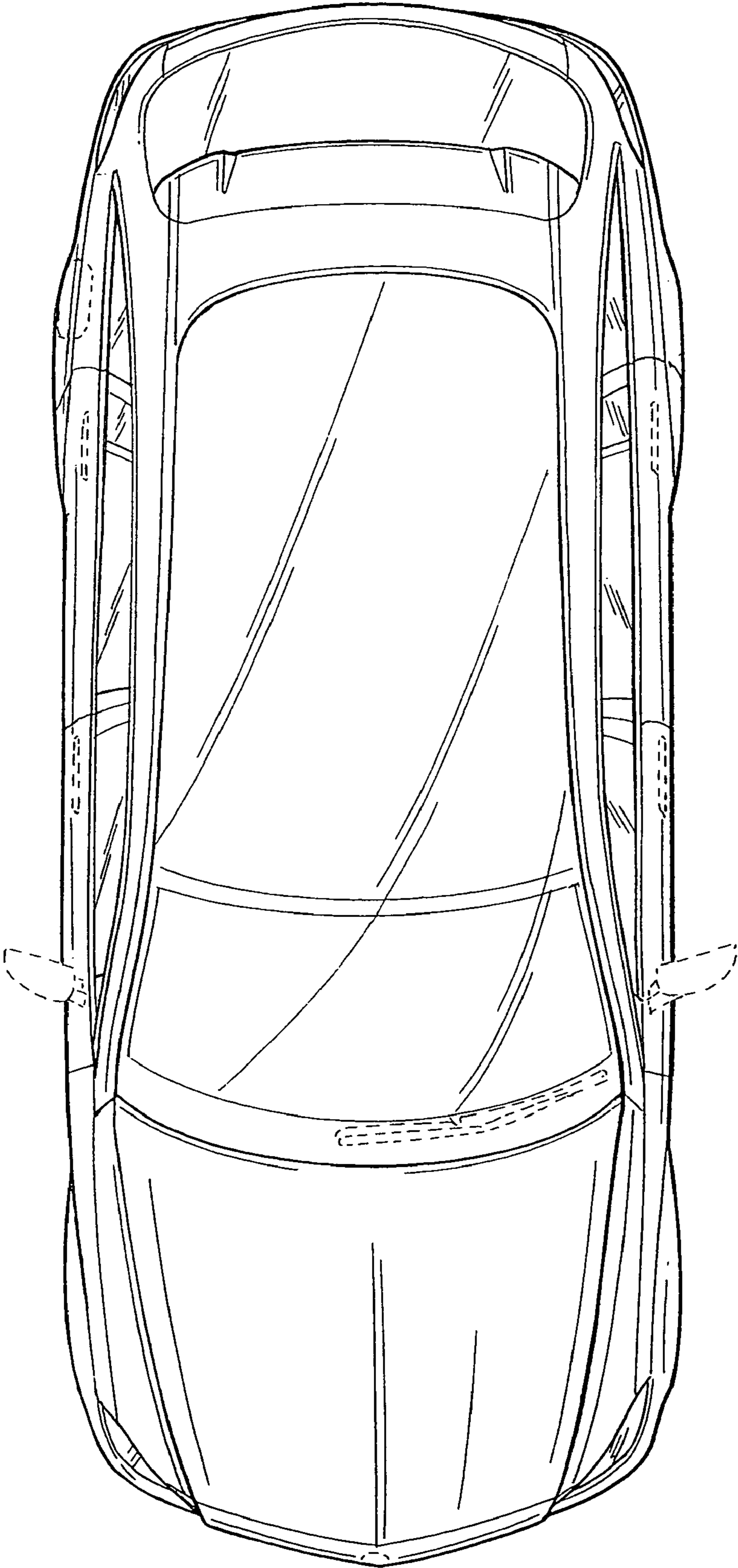

FIG. 7