



US00D634177S

(12) **United States Design Patent**
Owens

(10) **Patent No.:** **US D634,177 S**

(45) **Date of Patent:** **** Mar. 15, 2011**

(54) **CABINET KNOB**

(75) **Inventor:** **Ashley Marie Owens**, Bossier City, LA
(US)

(73) **Assignee:** **Hardware Resources, Inc.**, Bossier
City, LA (US)

(**) **Term:** **14 Years**

(21) **Appl. No.:** **29/370,262**

(22) **Filed:** **Jun. 22, 2010**

(51) **LOC (9) Cl.** **08-06**

(52) **U.S. Cl.** **D8/310**

(58) **Field of Classification Search** D8/310,
D8/300, 301, 302, 303, 305, 307, 312, 317,
D8/318, 319, 320; D6/491, 550; D7/393,
D7/396; D11/95; D21/385, 386; 16/110.1,
16/412, 414, 415, 417, 433, 441, 442; 292/347,
292/348, 349, 350, 355, 356, 357

See application file for complete search history.

(56) **References Cited**

U.S. PATENT DOCUMENTS

D267,774 S *	2/1983	Pittenger	D8/317
D405,216 S *	2/1999	Porter et al.	D26/138
D442,055 S *	5/2001	Dewald et al.	D8/310
D470,740 S *	2/2003	Fields	D8/310
D470,741 S *	2/2003	Fields	D8/310

D499,631 S *	12/2004	Sale, Jr.	D8/310
D510,696 S *	10/2005	Sale, Jr.	D8/310
D530,593 S *	10/2006	Kosasih et al.	D8/310
D543,088 S *	5/2007	Ricereto	D8/310
D574,212 S *	8/2008	Jou	D8/305
D575,622 S *	8/2008	Krumpe	D8/315
D580,736 S *	11/2008	Matijevic	D8/310

* cited by examiner

Primary Examiner — Prabhakar Deshmukh

Assistant Examiner — Derrick Holland

(74) *Attorney, Agent, or Firm* — Schultz & Associates, P.C.

(57) **CLAIM**

The ornamental design for a cabinet knob, as shown and described.

DESCRIPTION

FIG. 1 is a perspective view of a cabinet knob showing my new design;

FIG. 2 is a first side elevation view thereof;

FIG. 3 is a top plan view thereof;

FIG. 4 is a second side elevation view thereof; and,

FIG. 5 is a bottom plan view thereof.

The broken lines shown represent unclaimed subject matter and form no part of the claimed design.

1 Claim, 3 Drawing Sheets

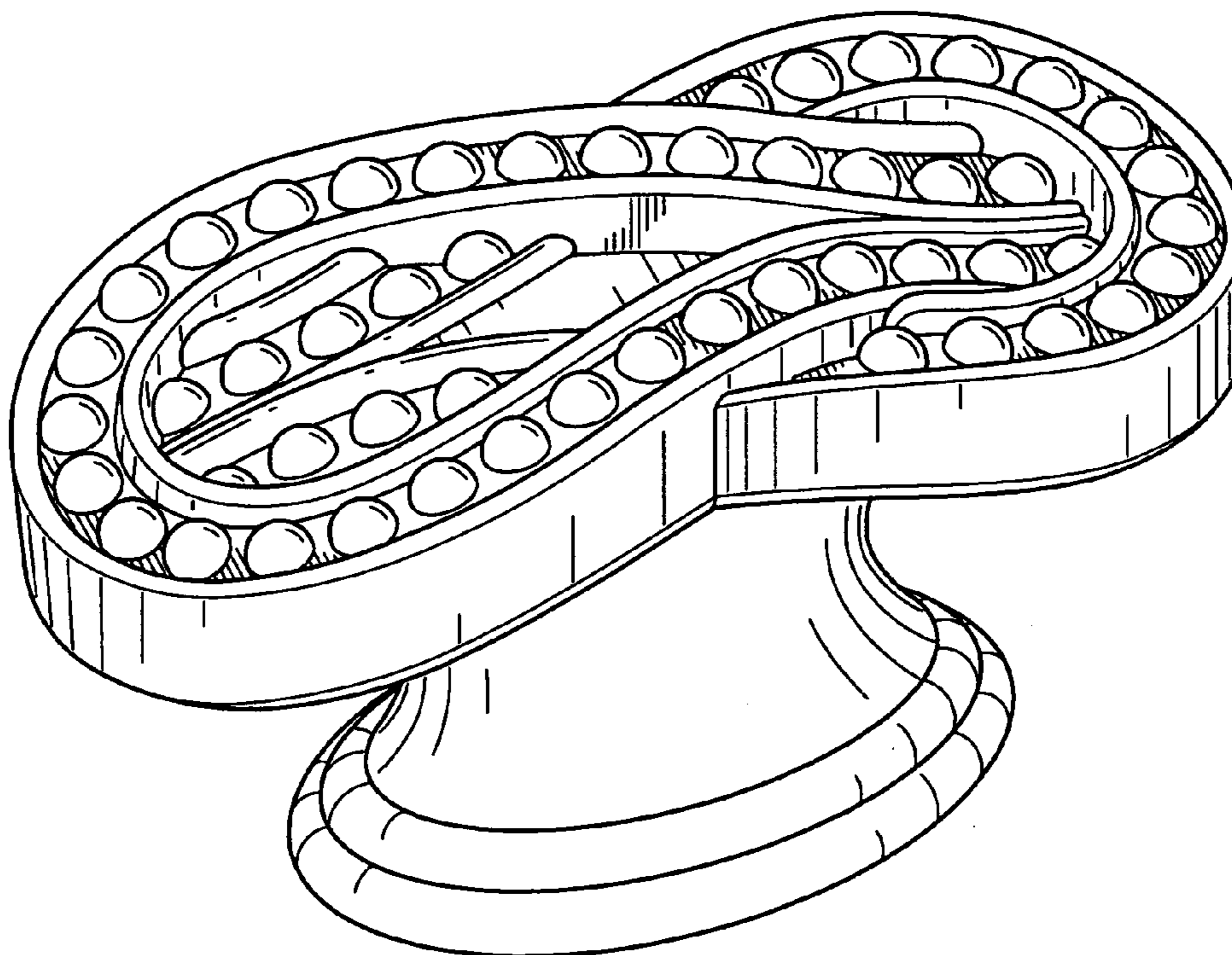

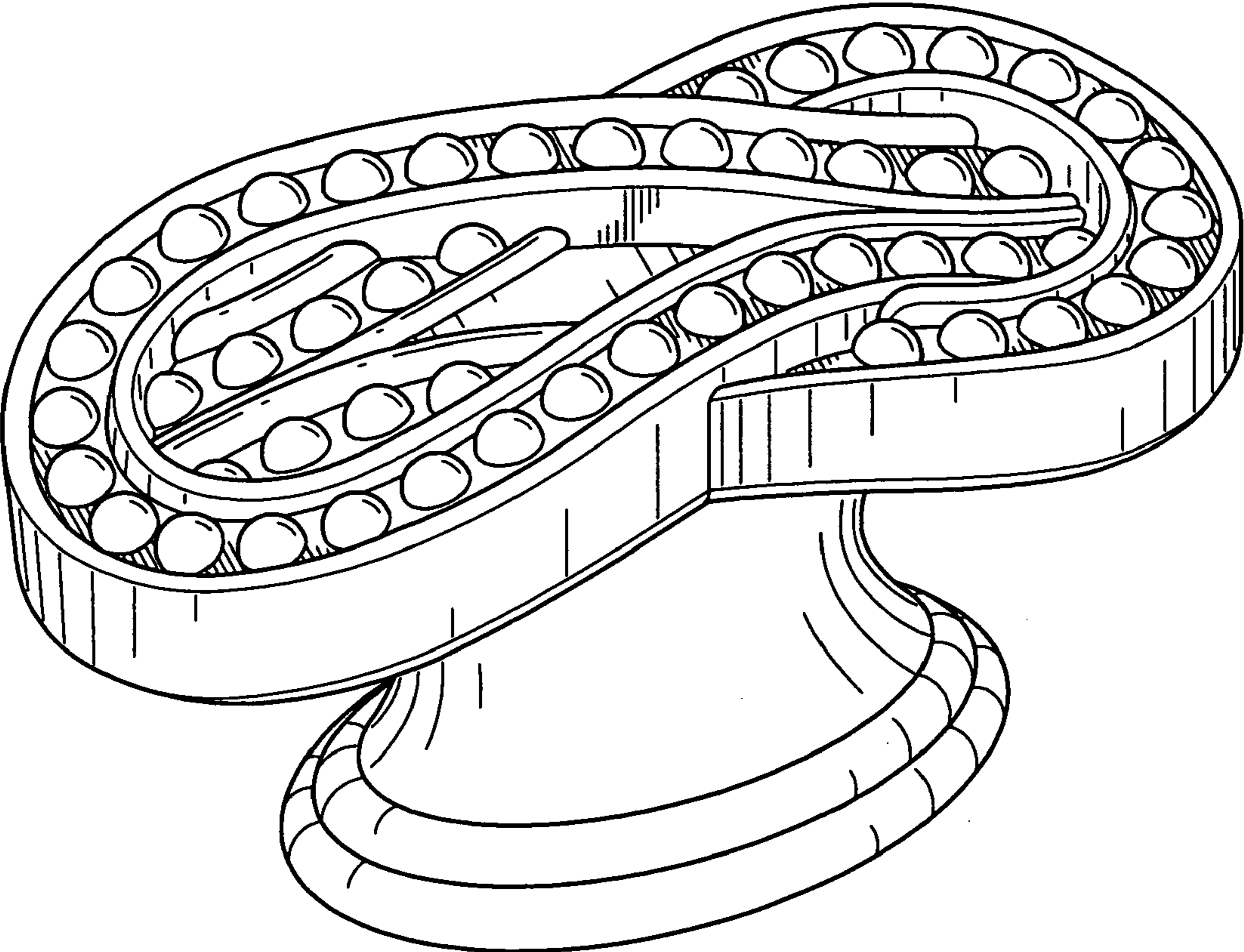

FIG. 1

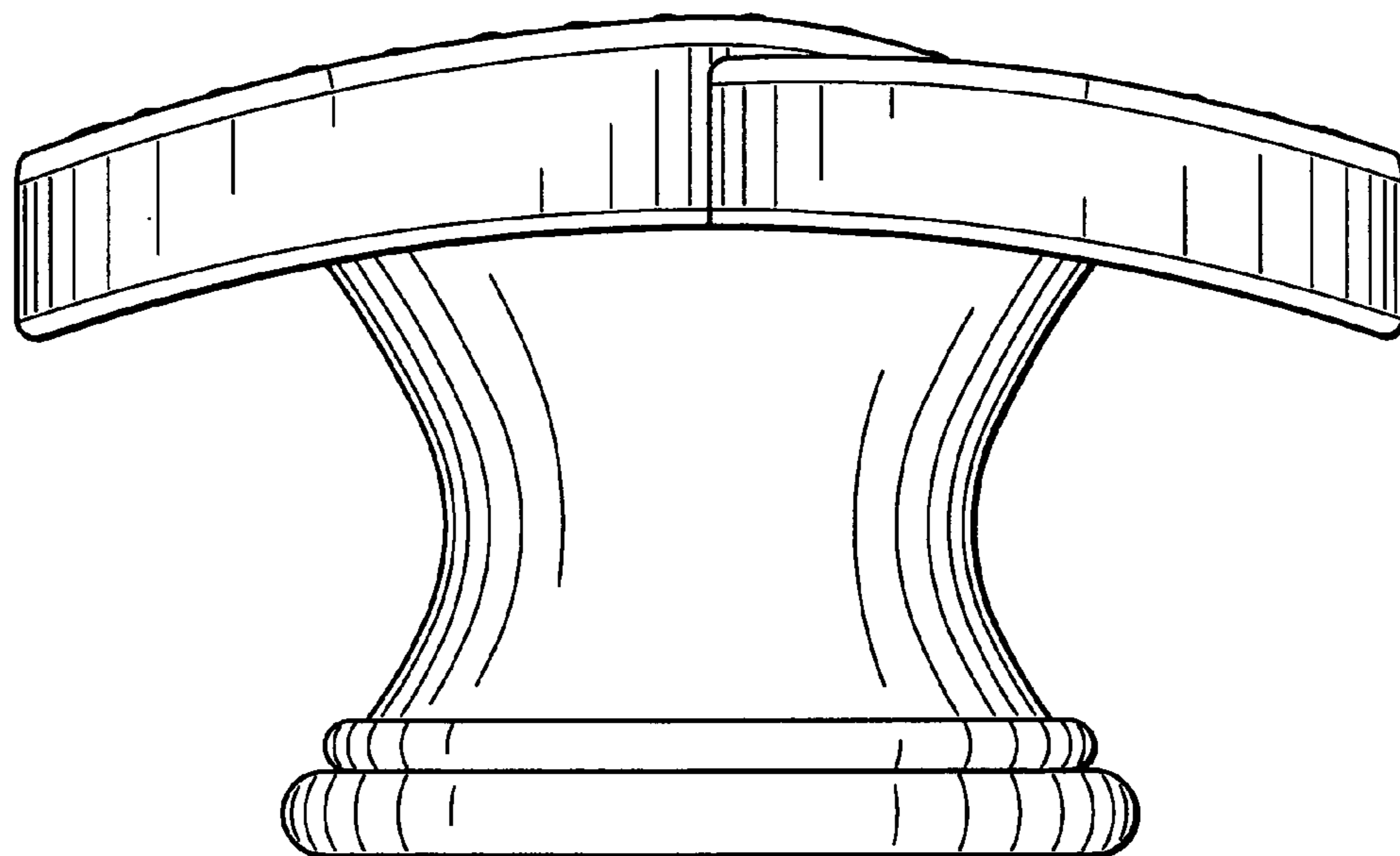

FIG. 2

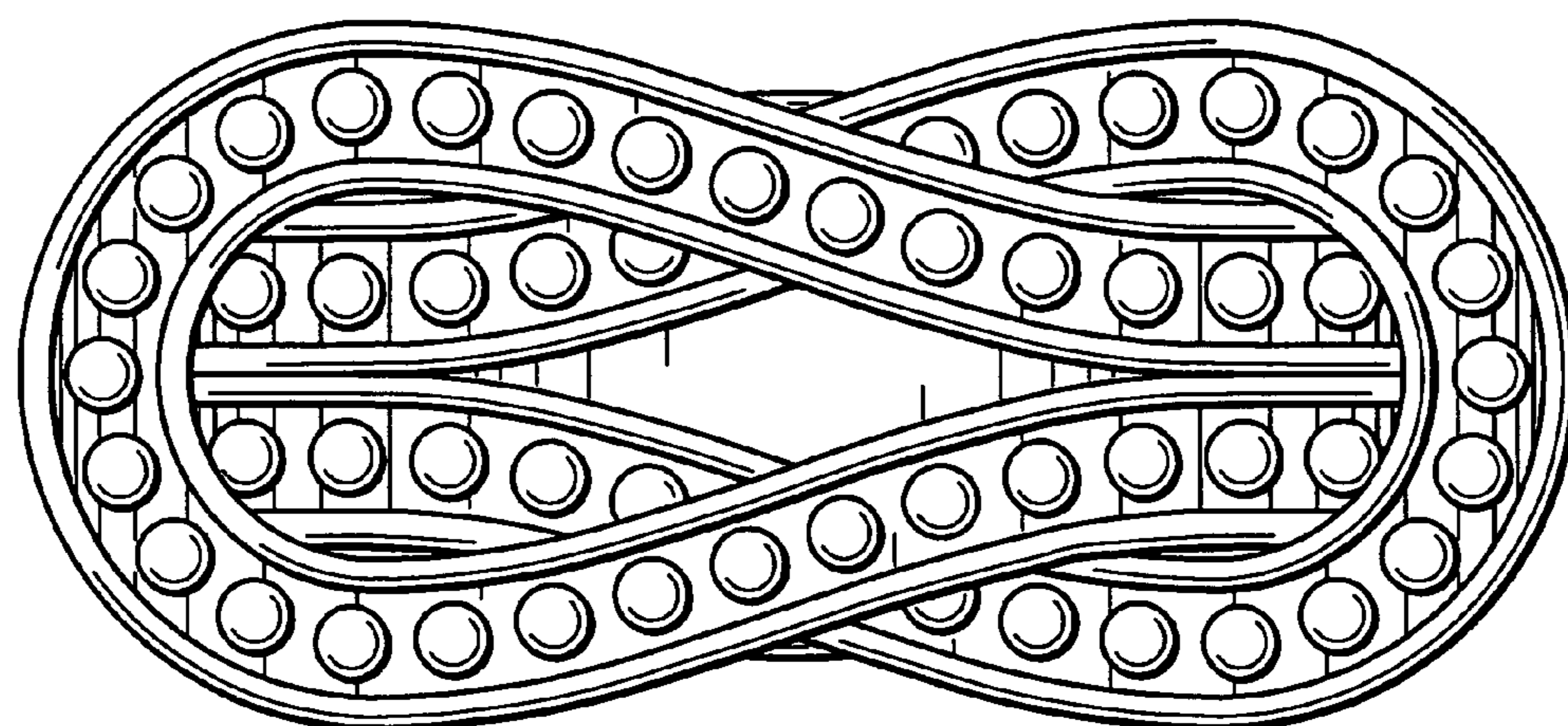

FIG. 3

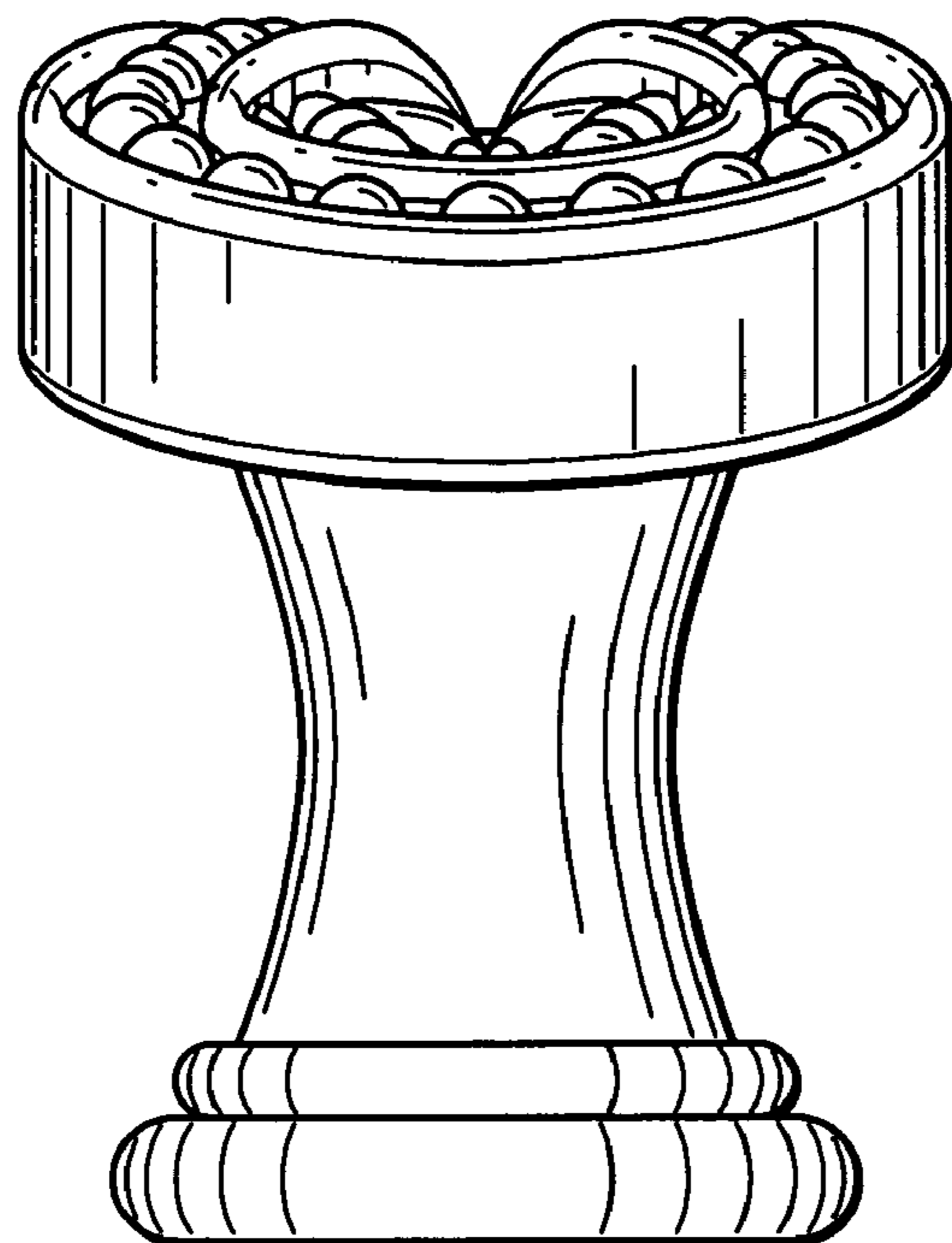

FIG. 4

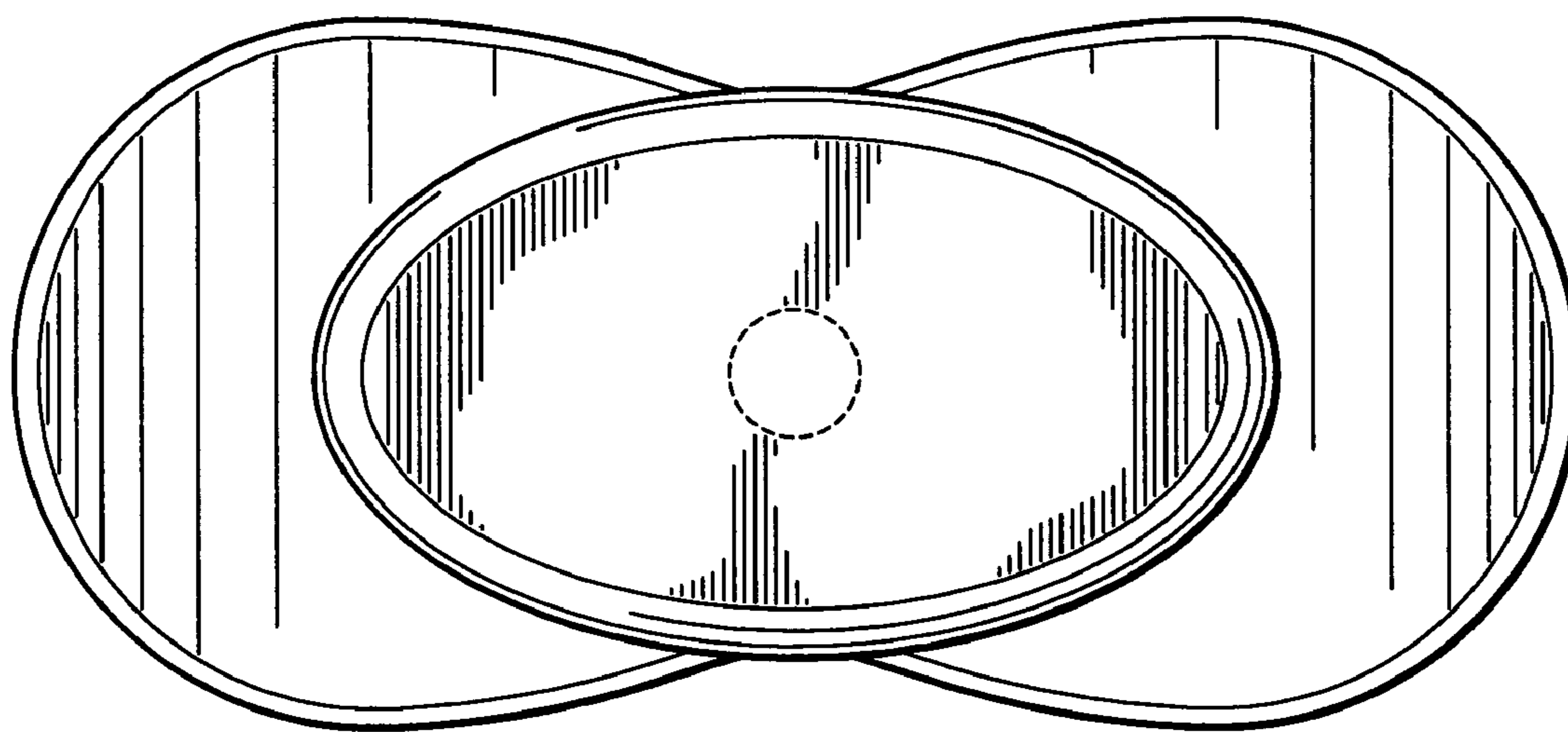

FIG. 5