



US00D634093S

(12) **United States Design Patent**
Wagner

(10) **Patent No.:** **US D634,093 S**
(45) **Date of Patent:** **** Mar. 8, 2011**

(54) **BOAT MOTOR MAILBOX DESIGN**

(75) Inventor: **Thomas E. Wagner**, Fenton, MO (US)

(73) Assignees: **Wagner Products Co.**, Fenton, MO (US); **Mo. Corp.**, Fenton, MO (US)

(**) Term: **14 Years**

(21) Appl. No.: **29/349,205**

(22) Filed: **Mar. 16, 2010**

(51) **LOC (9) Cl.** **25-03**

(52) **U.S. Cl.** **D99/30; D99/32**

(58) **Field of Classification Search** **D99/28-32; 232/17, 19, 38, 24; 440/53, 52; 446/162-165**
See application file for complete search history.

(56) **References Cited**

U.S. PATENT DOCUMENTS

5,000,379	A *	3/1991	LaRue	232/17
D439,723	S	3/2001	Avery		
6,299,325	B1	10/2001	Cathel		
D460,599	S *	7/2002	Wrob	D99/30
D479,382	S *	9/2003	Yeager	D99/30
6,708,876	B1	3/2004	Shirah		
6,719,193	B2	4/2004	Katulka		
6,772,939	B1	8/2004	Simpson		
6,779,714	B2	8/2004	Webb		

7,249,705	B2	7/2007	Dudley
2003/0124025	A1	7/2003	Mize et al.
2003/0205614	A1	11/2003	Klima et al.
2004/0022671	A1	2/2004	Malatesta

* cited by examiner

Primary Examiner—Lisa P Lichtenstein

(74) *Attorney, Agent, or Firm*—Paul M. Denk

(57) **CLAIM**

The ornamental design for the boat motor mailbox design, as shown and described.

DESCRIPTION

FIG. 1 is an isometric view of the boat motor mailbox design of this application;

FIG. 2 is a left side view, the right side view being a mere image thereof;

FIG. 3 is a front view;

FIG. 4 is a rear view;

FIG. 5 is a top plan view; and,

FIG. 6 is a bottom view.

The fragmentary showing of the vertical lines of the grill panels in FIGS. 1 and 5 is understood to extend uniformly throughout the areas represented.

1 Claim, 4 Drawing Sheets

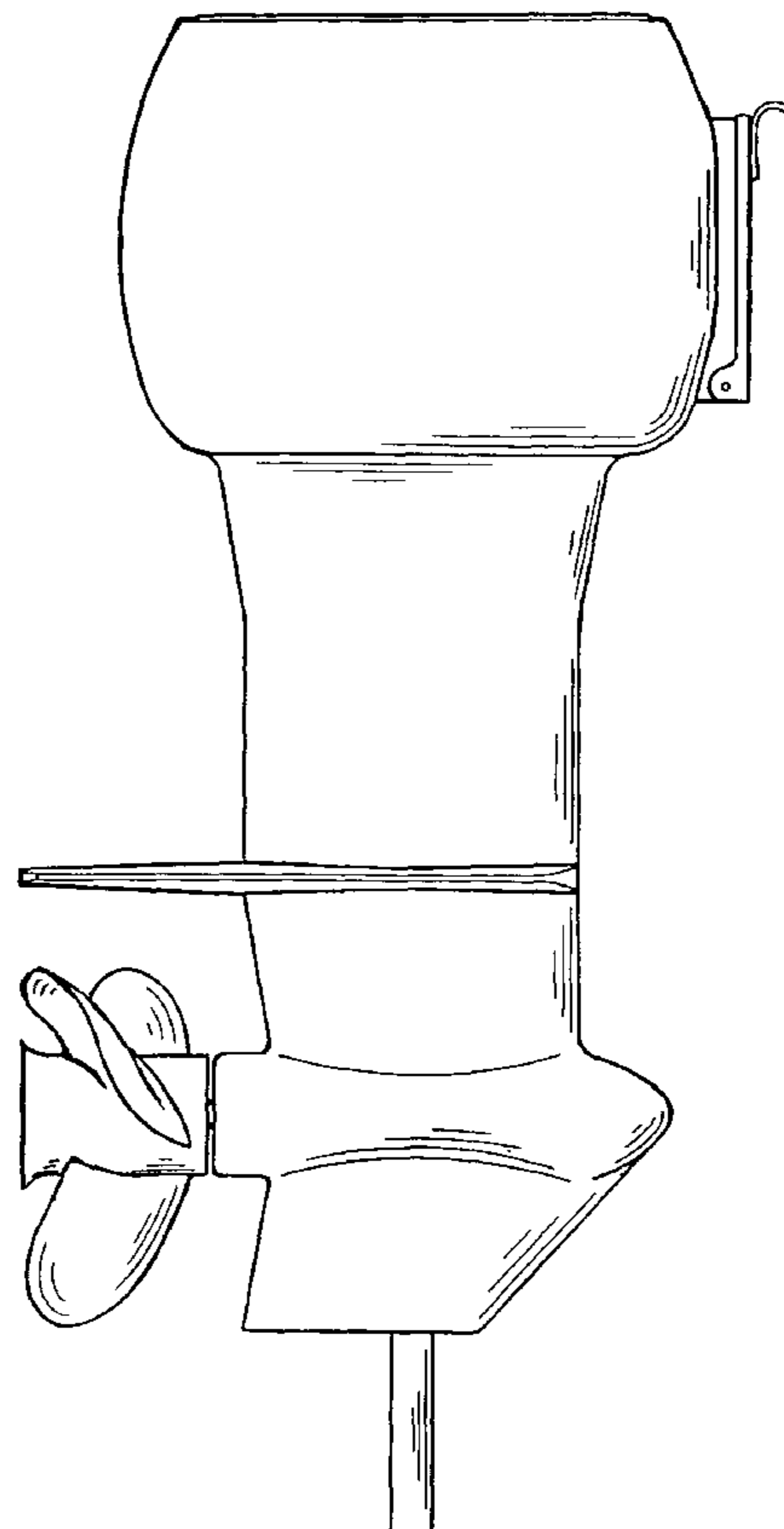
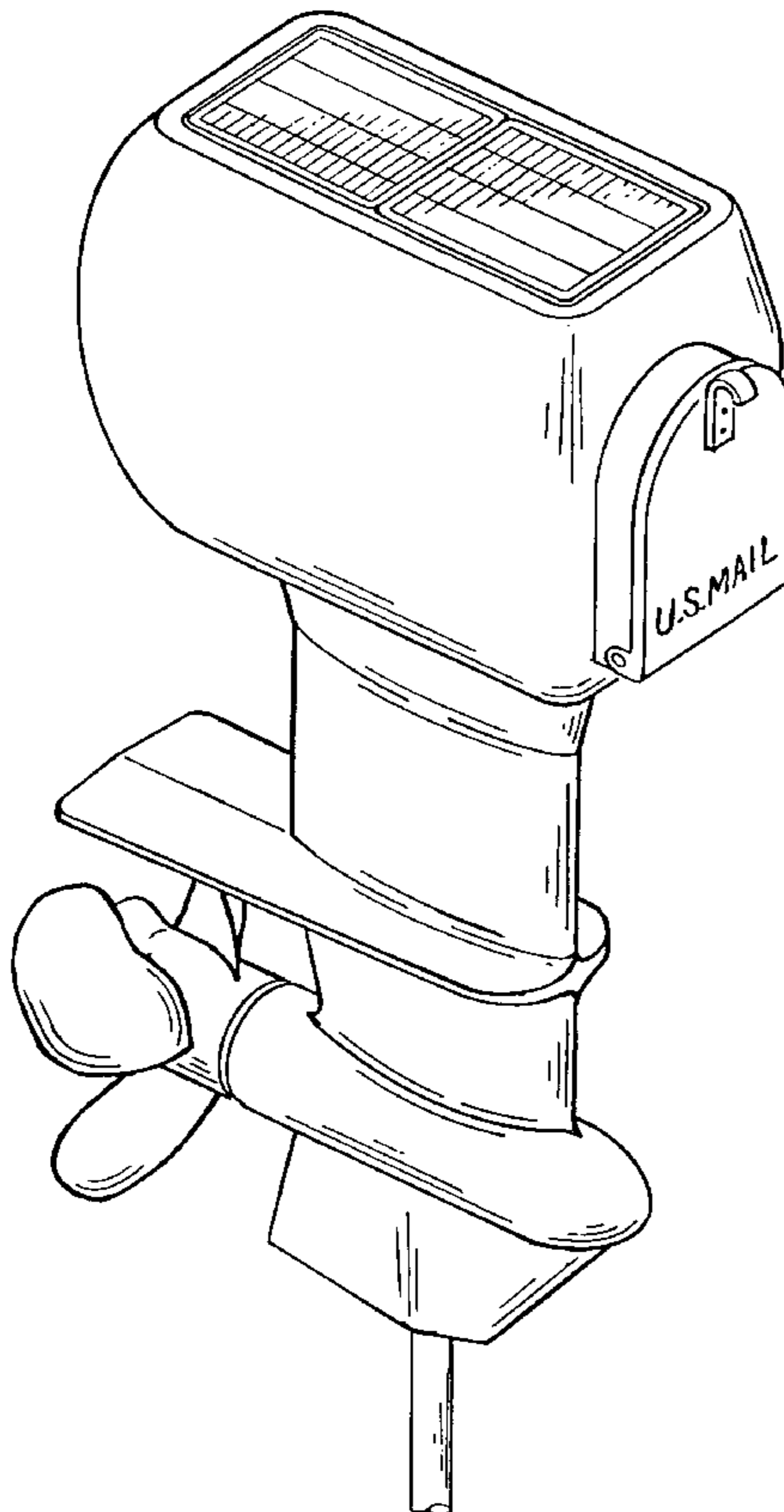

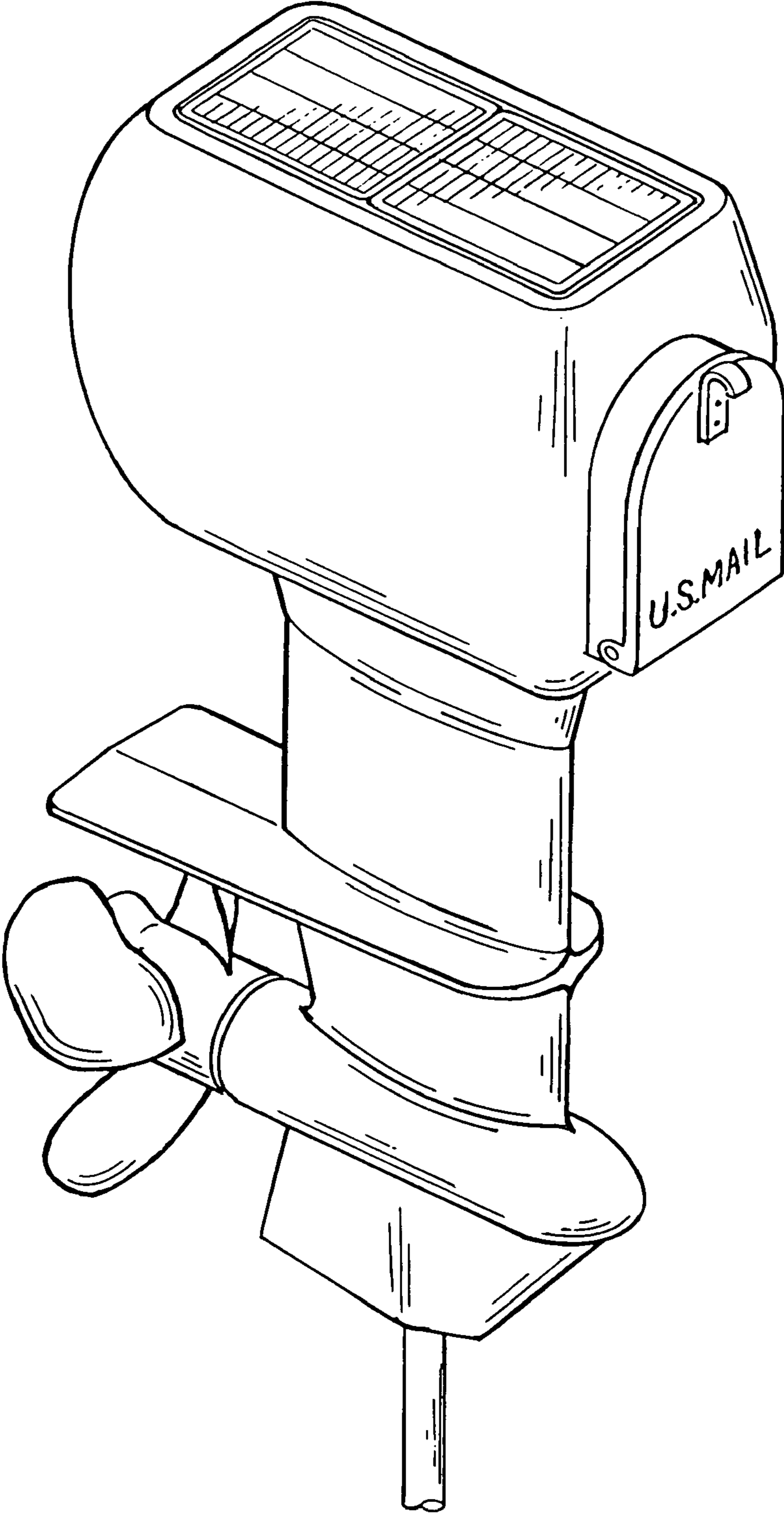

FIG. 1

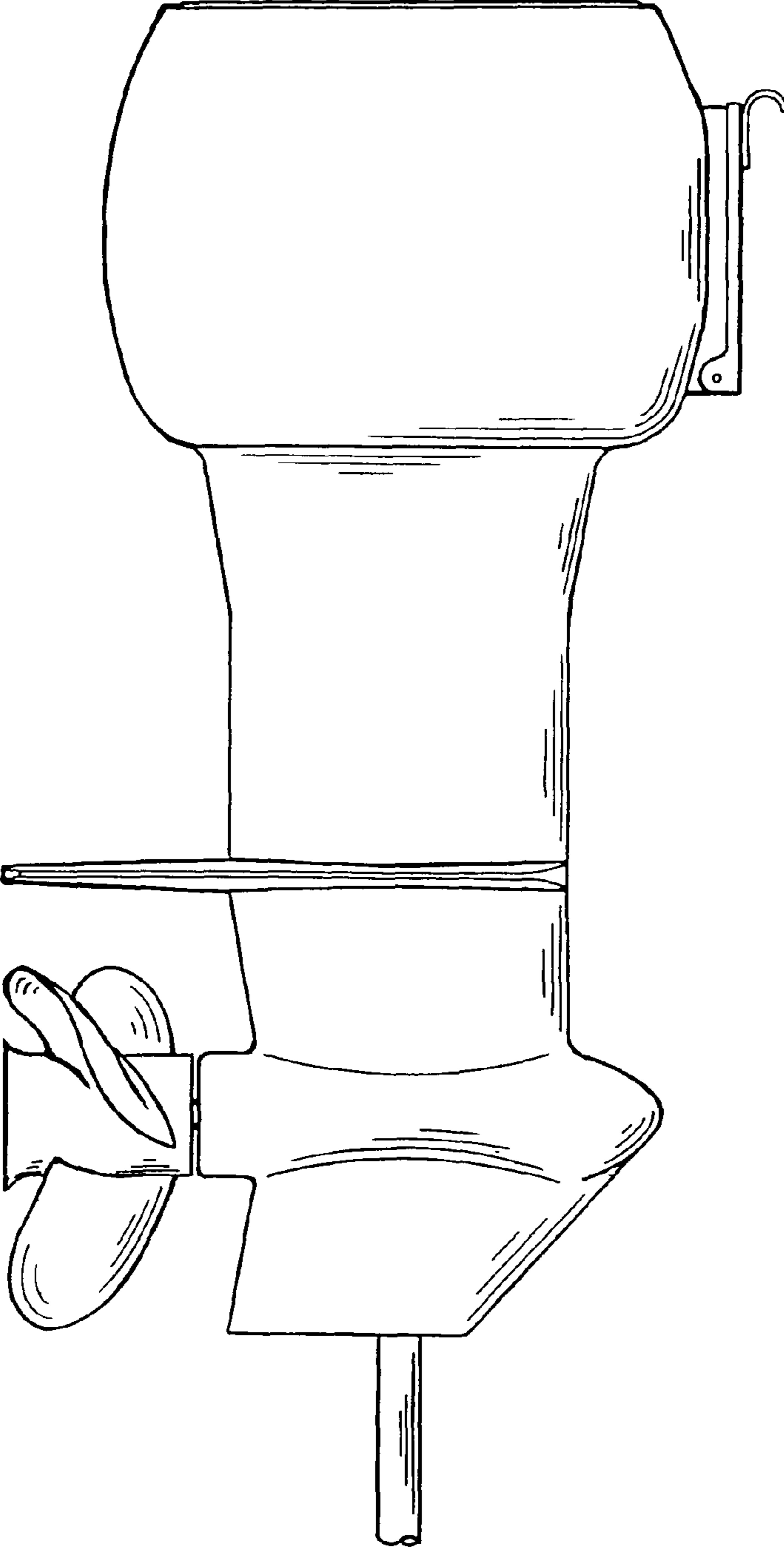

FIG. 2

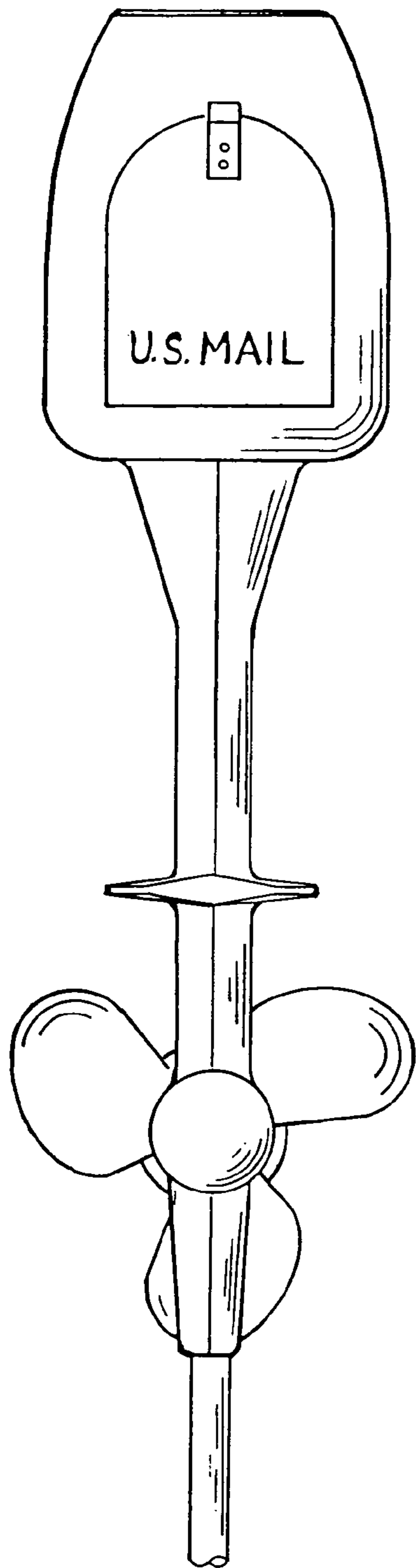

FIG. 3

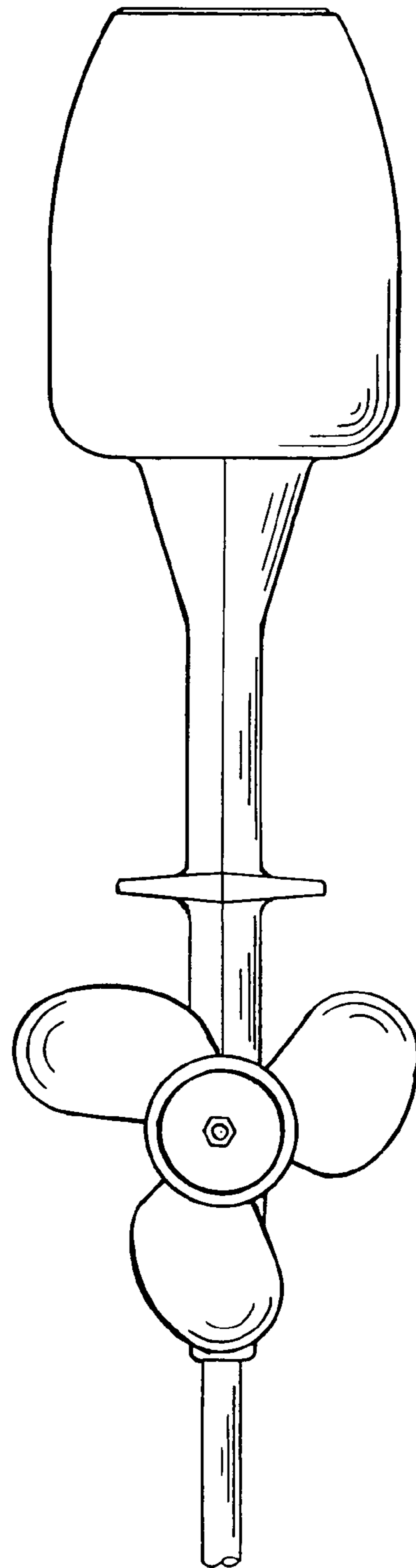

FIG. 4

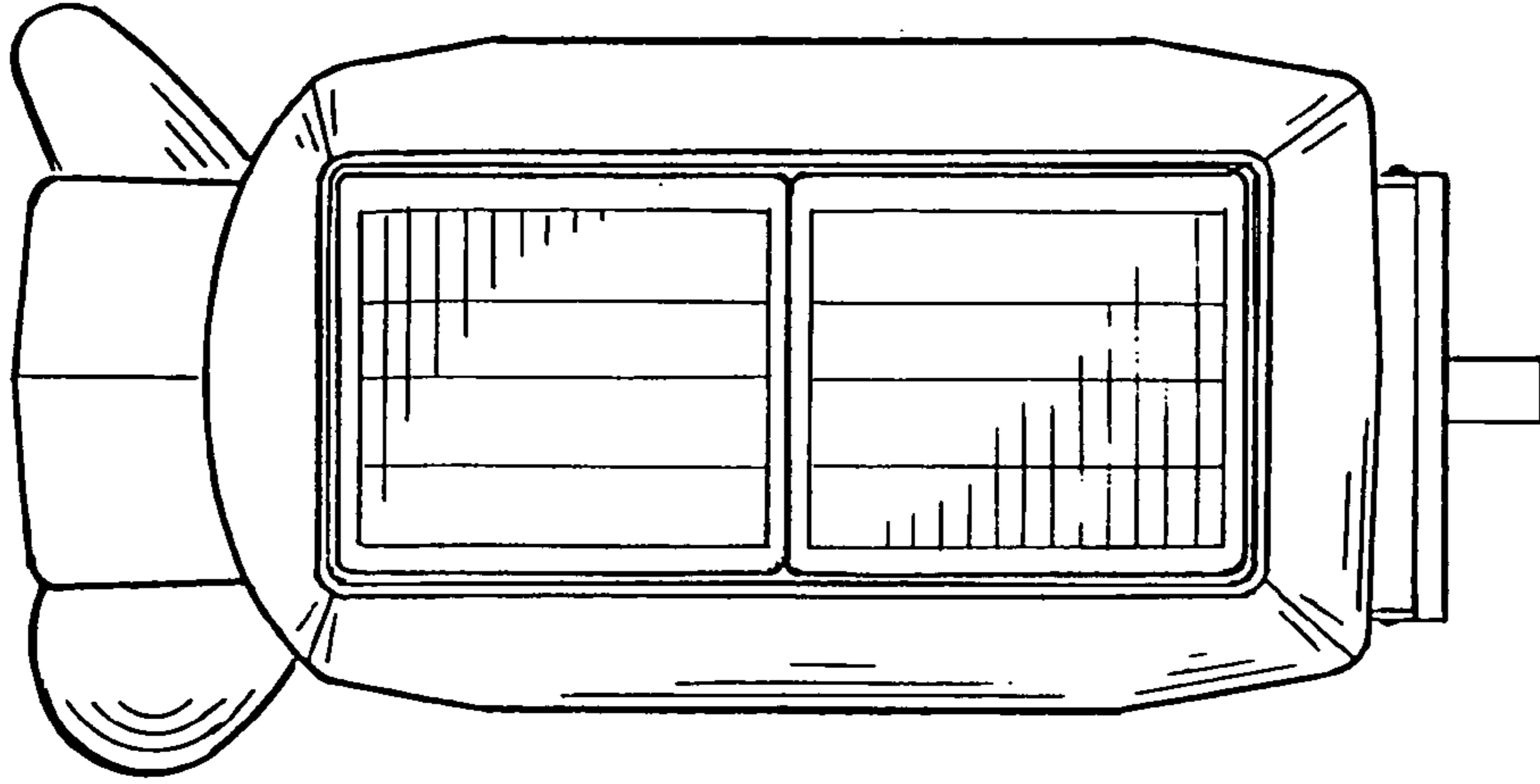

FIG. 5

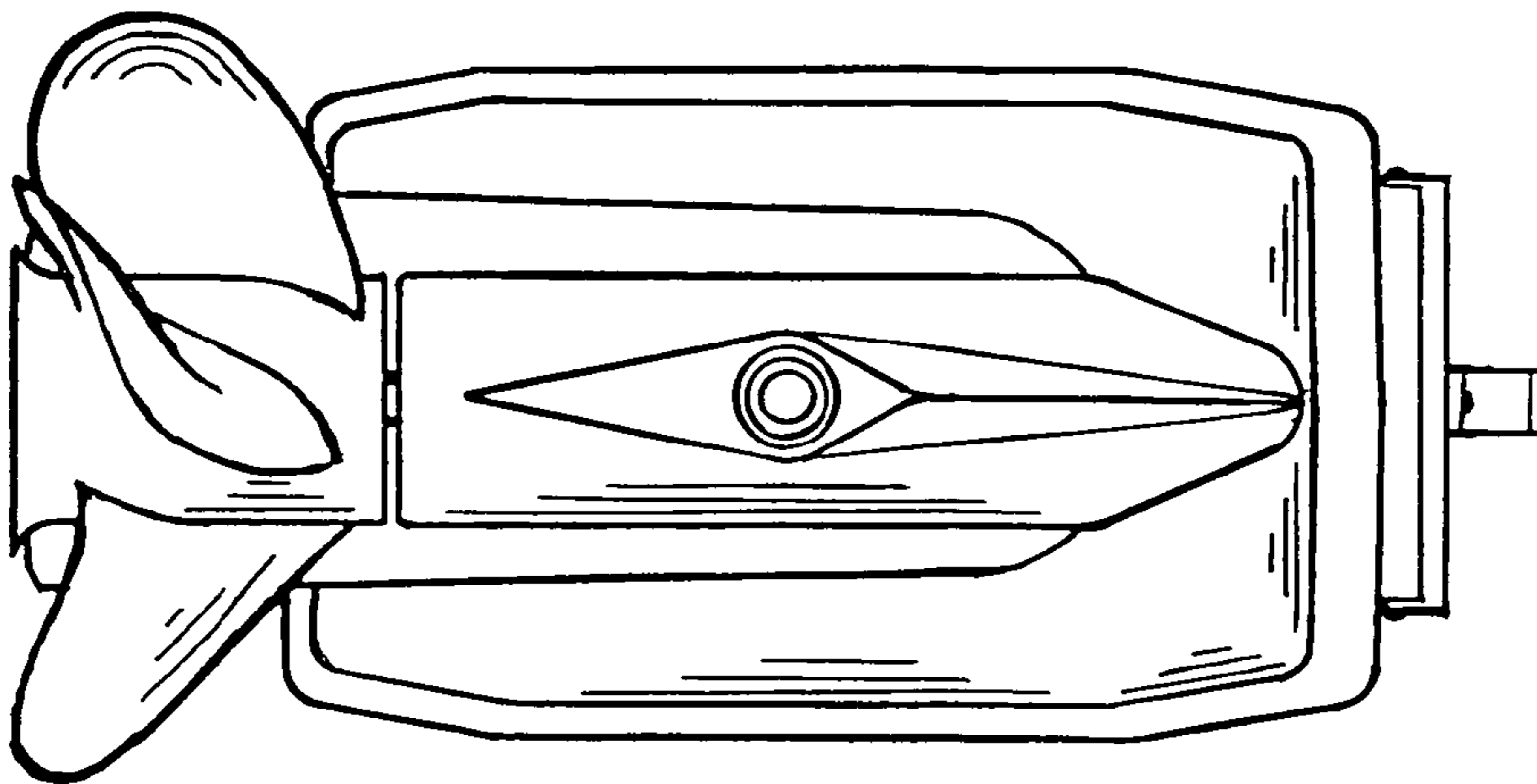

FIG. 6