

US00D633682S

(12) **United States Design Patent**
Schmid

(10) **Patent No.:** **US D633,682 S**
(45) **Date of Patent:** **** Mar. 1, 2011**

(54) **HAND TRUCK**

(76) Inventor: **Rene Schmid**, Hinterforst (CH)

(**) Term: **14 Years**

(21) Appl. No.: **29/370,218**

(22) Filed: **Jun. 17, 2010**

(30) **Foreign Application Priority Data**

Dec. 18, 2009 (EM) 001649559

(51) **LOC (9) Cl.** **12-02**

(52) **U.S. Cl.** **D34/26**

(58) **Field of Classification Search** D34/12-27;
280/47.24, 47.17, 47.19, 47.26, 47.34, 47.35,
280/49.3, 79.6, 472

See application file for complete search history.

(56) **References Cited**

U.S. PATENT DOCUMENTS

D200,401 S * 2/1965 Olson D34/18
D441,935 S * 5/2001 Cook D34/24
D451,257 S * 11/2001 Moritsch D34/24
D580,610 S * 11/2008 Hawkins D32/25

D590,110 S * 4/2009 Hawkins D32/25
D622,471 S * 8/2010 Hernandez D34/12
2008/0272578 A1 * 11/2008 Tsai 280/651
2010/0102526 A1 * 4/2010 Schwager 280/47.24

* cited by examiner

Primary Examiner—Cynthia E Ramirez

(74) *Attorney, Agent, or Firm*—Pandiscio & Pandiscio

(57) **CLAIM**

The ornamental design for a hand truck, as shown and described.

DESCRIPTION

FIG. 1 is a perspective view of a hand truck showing my new design;

FIG. 2 is a left side elevational view thereof;

FIG. 3 is a right side elevational view thereof;

FIG. 4 is a front elevational view thereof;

FIG. 5 is a rear elevational view thereof;

FIG. 6 is a top plan view thereof; and,

FIG. 7 is a bottom plan view thereof.

1 Claim, 7 Drawing Sheets

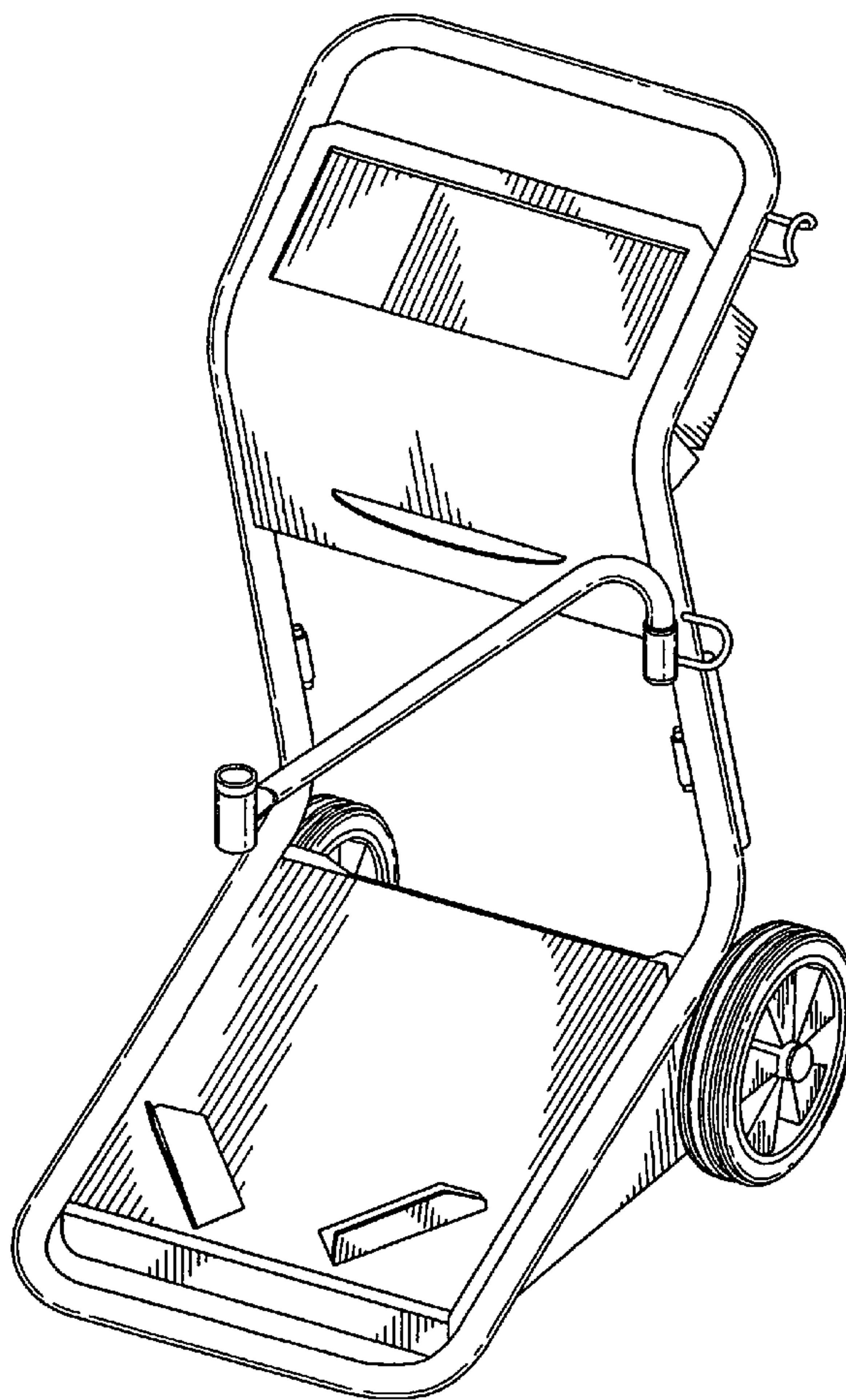

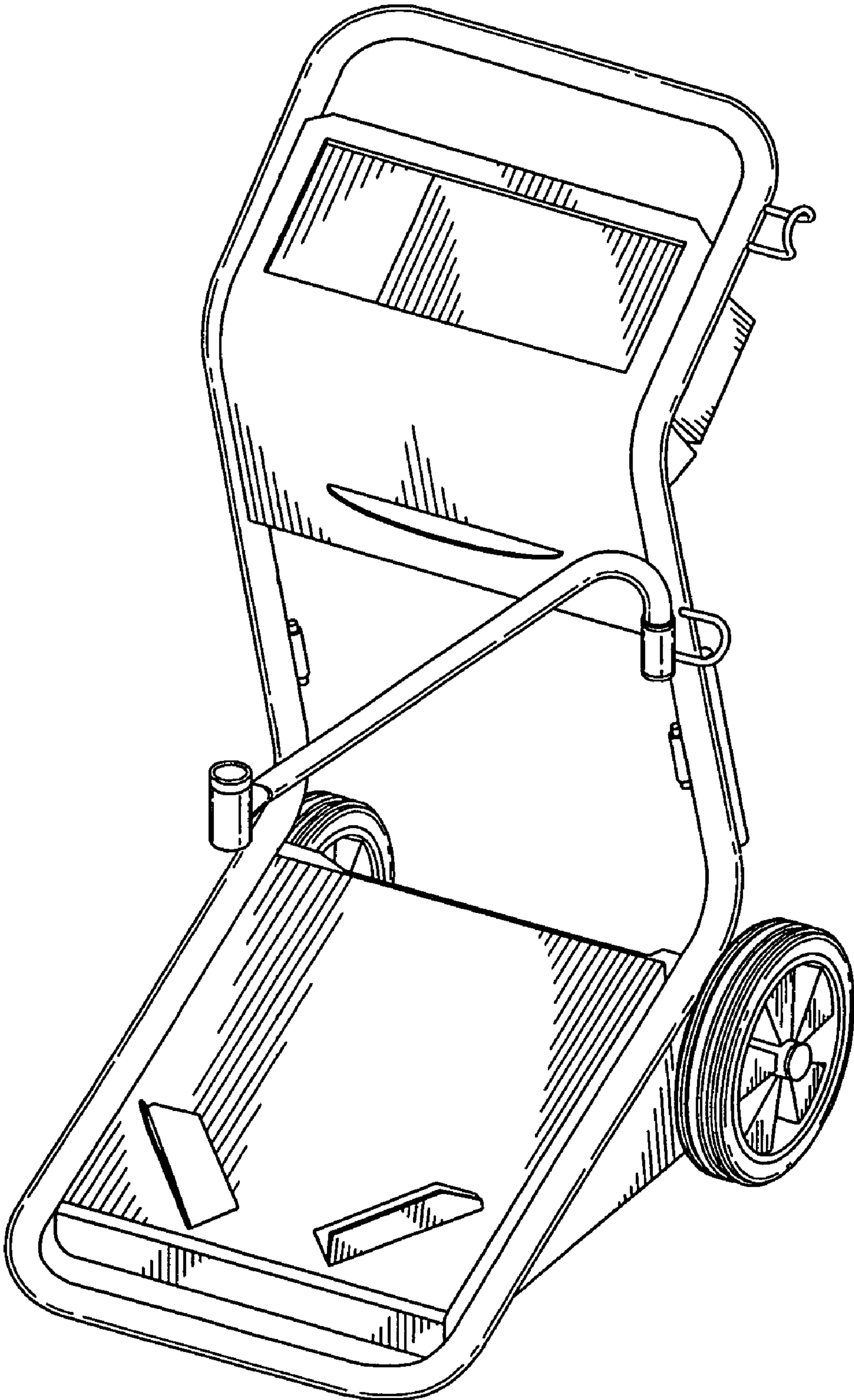

FIG. 1

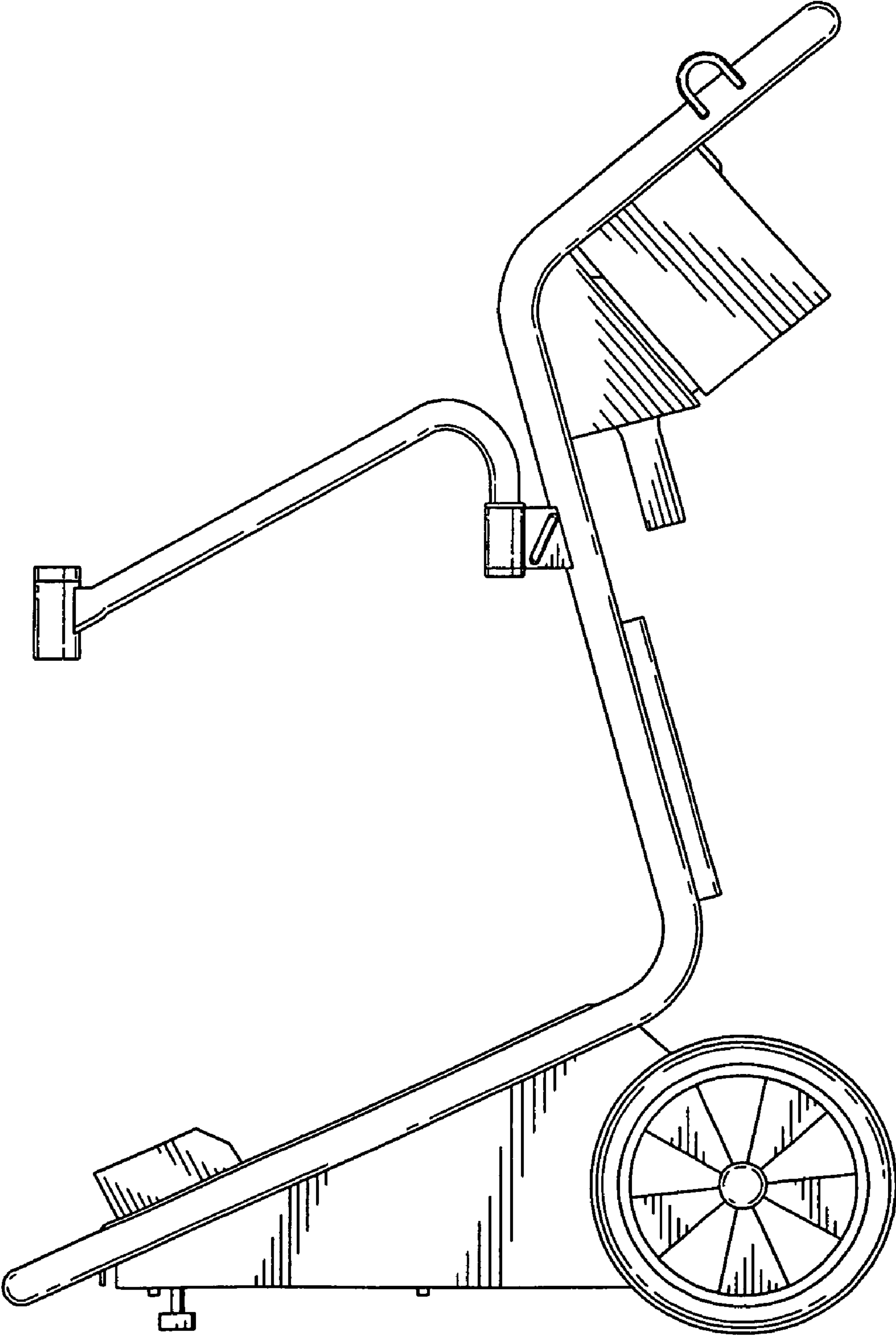

FIG. 2

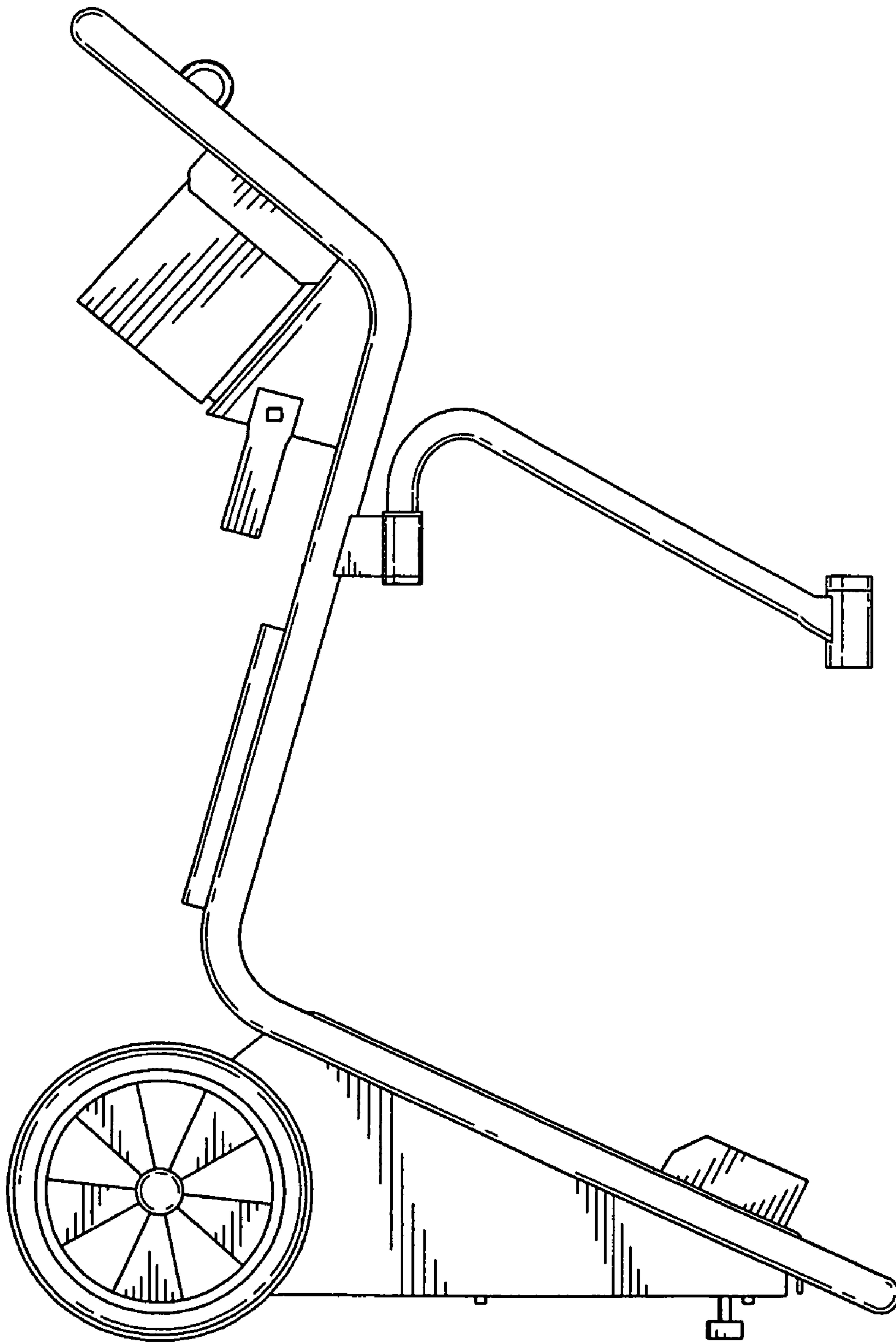

FIG. 3

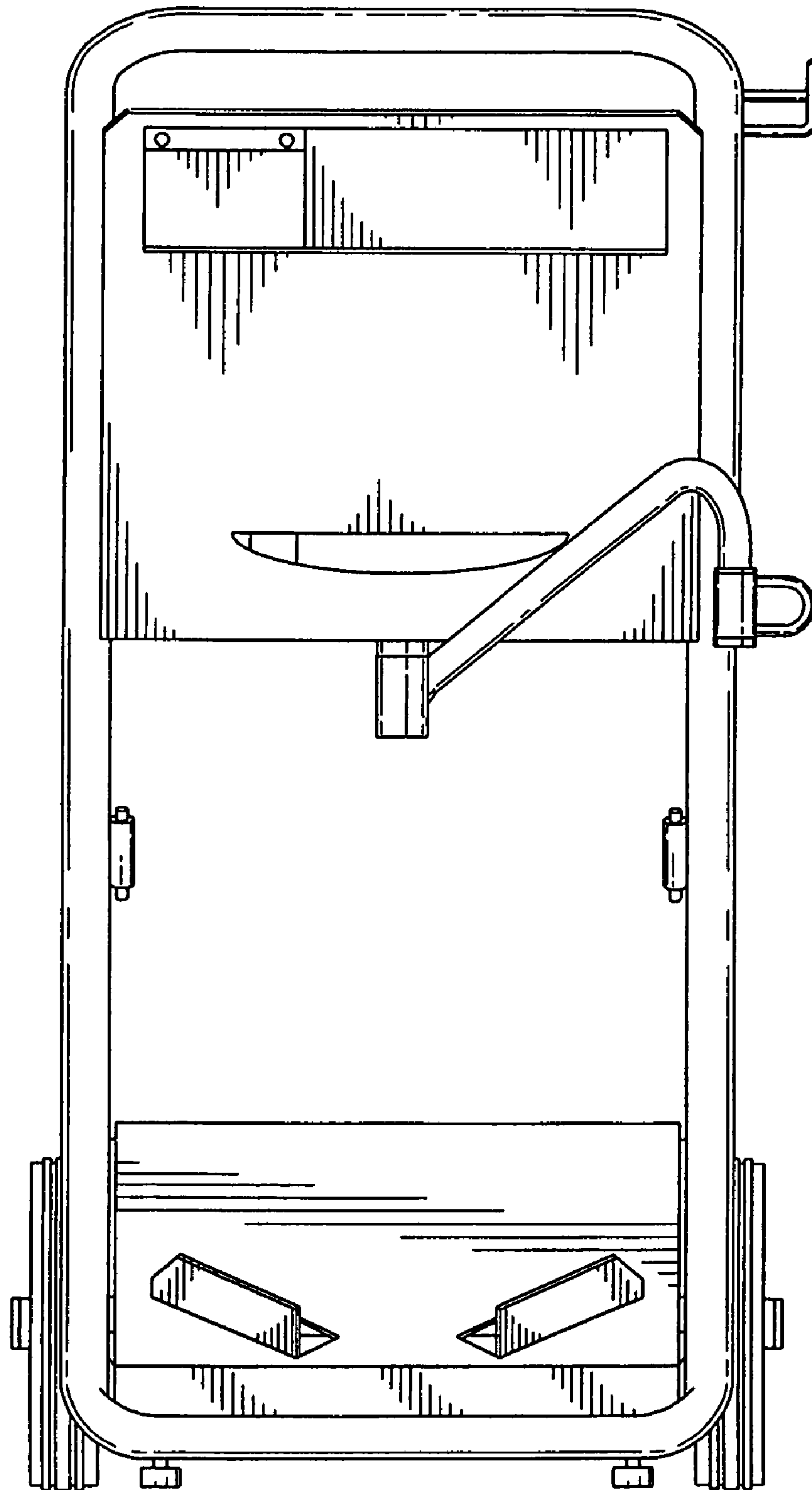

FIG. 4

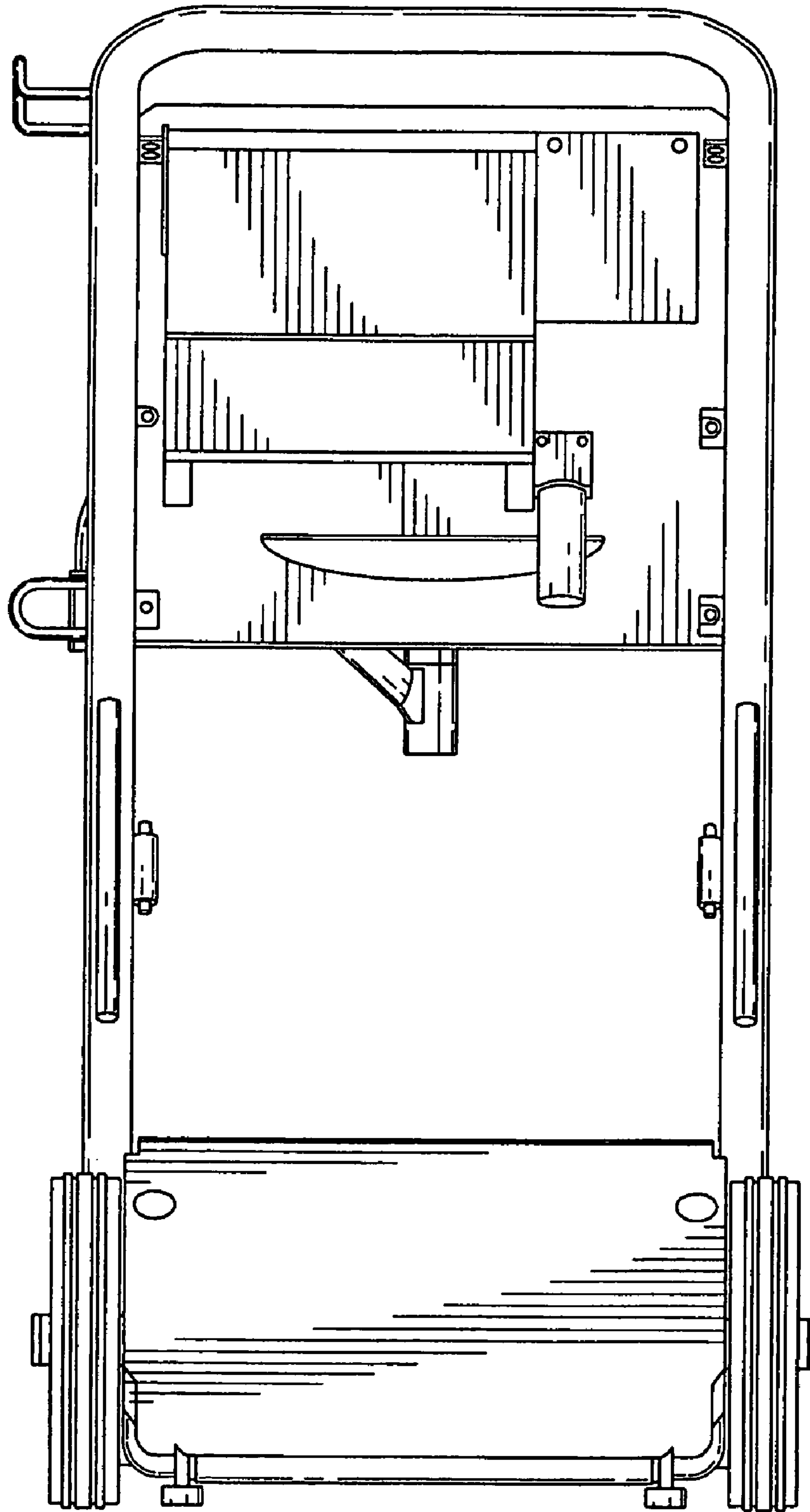

FIG. 5

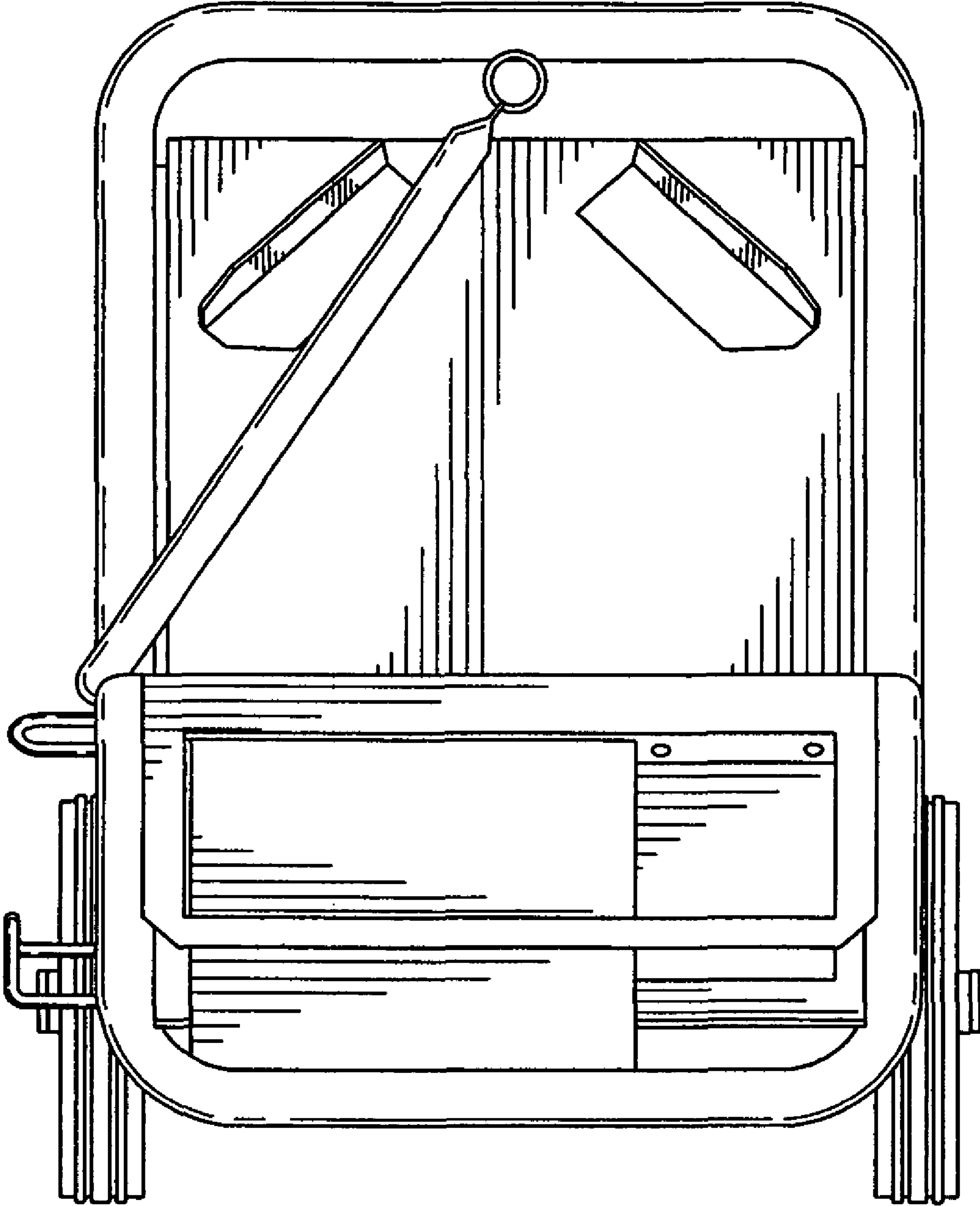

FIG. 6

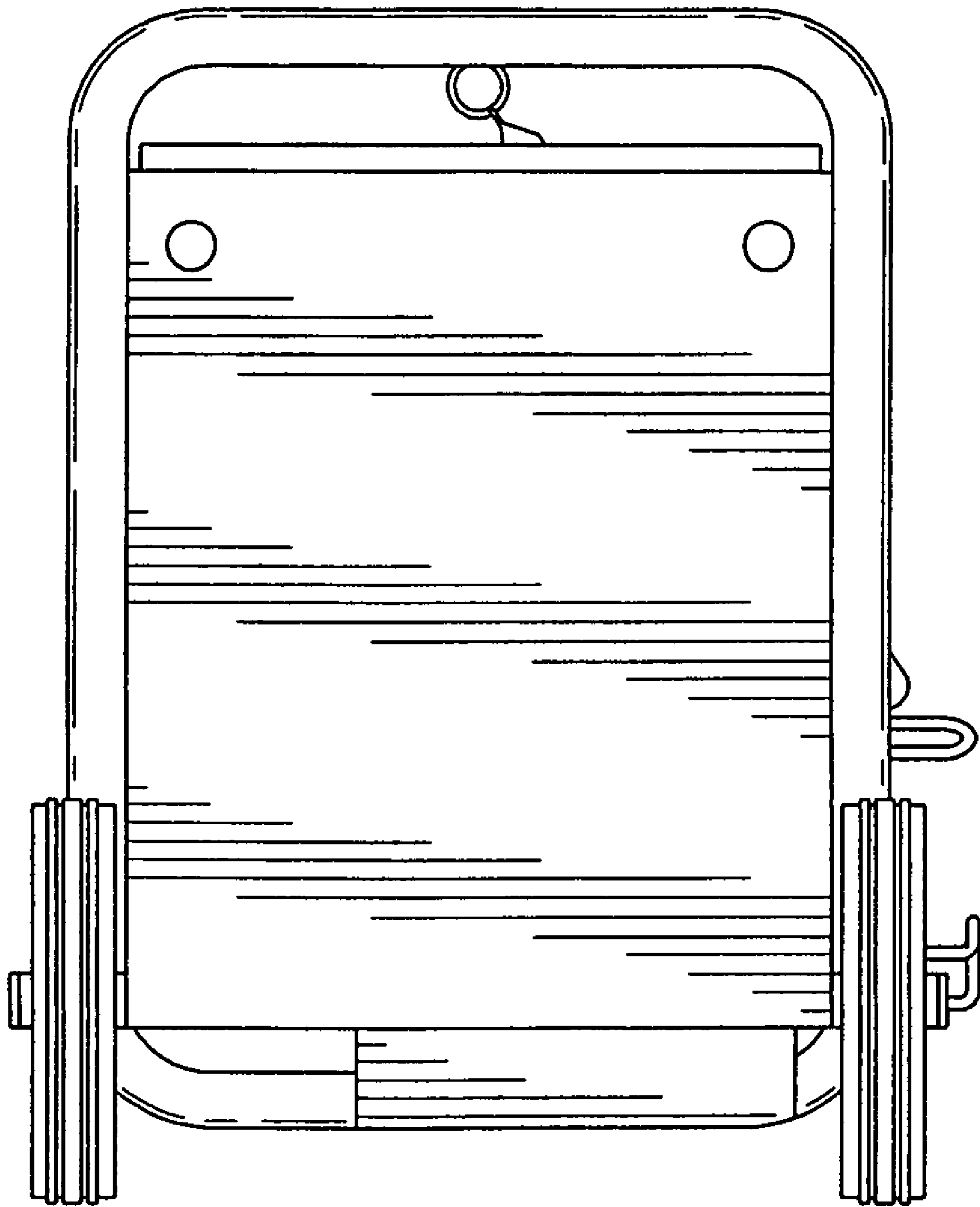

FIG. 7