



US00D633438S

(12) **United States Design Patent**  
**Sedberry et al.**

(10) **Patent No.:** **US D633,438 S**  
(45) **Date of Patent:** **\*\* Mar. 1, 2011**

(54) **TRANSFORMER**

(75) Inventors: **Erica Sedberry**, Dallas, TX (US); **Jack Lockhart**, Birmingham, AL (US); **Randall May**, Plano, TX (US); **Owen Slater**, Plano, TX (US); **Wai Wah Chung**, Kowloon (CN); **Hoi Wing Chin**, Tseung Kwan (CN); **Lance Thompson**, West Chicago, IL (US)

(73) Assignee: **J. Baxter Brinkmann International Corporation**, Dallas, TX (US)

(\*\*) Term: **14 Years**

(21) Appl. No.: **29/349,419**

(22) Filed: **Mar. 31, 2010**

(51) **LOC (9) Cl.** ..... **13-02**

(52) **U.S. Cl.** ..... **D13/110**

(58) **Field of Classification Search** ..... D13/110,  
D13/101, 118, 124, 184, 199; 174/52 R;  
220/4.02; 336/59, 60, 90, 92, 94, 98, 107,  
336/192; 363/153, 171; 307/150

See application file for complete search history.

(56) **References Cited**

U.S. PATENT DOCUMENTS

2,325,470 A \* 7/1943 Bonanno et al. .... 336/92

(Continued)

OTHER PUBLICATIONS

Intermatic 600-Watt Low Voltage Transformer at Internet website  
www.lowes.com, printed Mar. 10, 2009 (1 pg.).

(Continued)

*Primary Examiner*—Prabhakar Deshmukh

*Assistant Examiner*—Derrick Holland

(74) *Attorney, Agent, or Firm*—Sheppard, Mullin, Richter &  
Hampton LLP

(57) **CLAIM**

We claim the ornamental design for a transformer, as shown and described.

**DESCRIPTION**

FIG. 1 is a perspective view of the transformer showing the new design, with the front panel of the transformer open;

FIG. 2 is a front elevational view of the transformer depicted in FIG. 1;

FIG. 3 is a rear elevational view of the transformer depicted in FIG. 1;

FIG. 4 is a right side elevational view of the transformer depicted in FIG. 1,

FIG. 5 is a left side elevational view of the transformer depicted in FIG. 1;

FIG. 6 is a top plan view of the transformer depicted in FIG. 1; and

FIG. 7 is a bottom plan view of the transformer depicted in FIG. 1.

FIG. 8 is a perspective view of the transformer showing the new design, with the front panel of the transformer closed;

FIG. 9 is a front elevational view of the transformer depicted in FIG. 8;

FIG. 10 is a rear elevational view of the transformer depicted in FIG. 8;

FIG. 11 is a right side elevational view of the transformer depicted in FIG. 8,

FIG. 12 is a left side elevational view of the transformer depicted in FIG. 8;

FIG. 13 is a top plan view of the transformer depicted in FIGS. 8; and,

FIG. 14 is a bottom plan view of the transformer depicted in FIG. 8.

The broken lines are for illustrative purposes only and form no part of the claimed design.

**1 Claim, 10 Drawing Sheets**

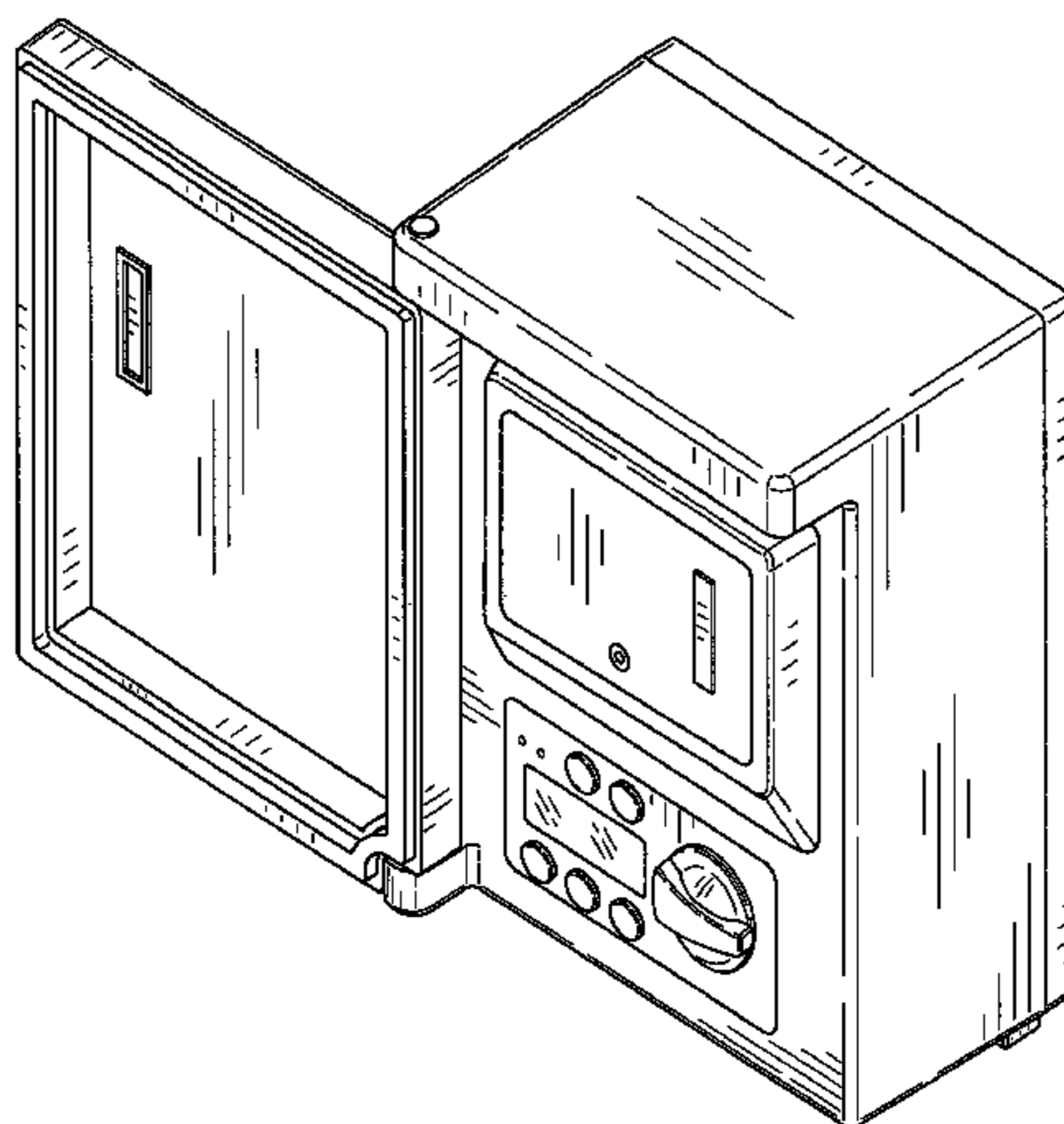

U.S. PATENT DOCUMENTS

3,056,893 A \* 10/1962 Russ ..... 307/150  
 D245,325 S \* 8/1977 Lindquist ..... D10/116  
 D254,846 S \* 4/1980 Wood ..... D13/110  
 D289,033 S \* 3/1987 Makinson et al. .... D13/110  
 D334,732 S \* 4/1993 Burgher et al. .... D13/110  
 6,121,889 A 9/2000 Janda et al.  
 D433,995 S \* 11/2000 Romano ..... D13/110  
 6,400,249 B1 6/2002 Jitaru  
 6,798,631 B1 9/2004 Farsetta  
 D500,686 S 1/2005 Stekelenburg  
 D500,687 S 1/2005 Morrison et al.  
 D535,897 S 1/2007 Leung  
 D538,742 S \* 3/2007 Pickvet et al. .... D13/110  
 7,332,992 B2 2/2008 Iwai  
 D574,770 S \* 8/2008 Liu ..... D13/116  
 D575,646 S 8/2008 Ni et al.  
 D582,797 S 12/2008 Fraser et al.  
 D591,181 S 4/2009 Kanbar

OTHER PUBLICATIONS

Pegasus Associates Lighting Low Voltage Transformers at Internet website <http://www.pegasusassociates.com/products/Transformers/trans.html>, printed Mar. 10, 2009 (1 pg.).  
 Photocell Landscape Light Transformer at Internet website [http://www.lampsplus.com/Products/Photocell-Landscape-Light-Transformer\\_06125.html](http://www.lampsplus.com/Products/Photocell-Landscape-Light-Transformer_06125.html), printed Mar. 11, 2009 (1 pg.).  
 150-Watt Transformer With Photocell and Timer at Internet website [http://www.lampsplus.com/Products/150-Watt-Transformer-With-Photocell-And-Timer\\_39549.html](http://www.lampsplus.com/Products/150-Watt-Transformer-With-Photocell-And-Timer_39549.html), printed Mar. 11, 2009 (1 pg.).  
 120 V and 240 V Electronic and Magnetic Transformers by Lacuna at Internet website [http://www.lacuna.in/Lacuna\\_transformers.html](http://www.lacuna.in/Lacuna_transformers.html), printed Mar. 11, 2009 (1 pg.).  
 Low Voltage Light Kit with Transformer at Internet webs <http://waterfeaturesusa.com/pond-low-voltage-lighting.htm>: [http://](http://waterfeaturesusa.com/pond-low-voltage-lighting.htm)

[waterfeaturesusa.com/pond-low-voltage-lighting.htm](http://waterfeaturesusa.com/pond-low-voltage-lighting.htm) : [http://](http://waterfeaturesusa.com/pond-low-voltage-lighting.htm)  
[waterfeaturesusa.com/pond-low-voltage-lighting.htm](http://waterfeaturesusa.com/pond-low-voltage-lighting.htm) : [http://](http://waterfeaturesusa.com/pond-low-voltage-lighting.htm)  
[waterfeaturesusa.com/pond-low-voltage-lighting.htm](http://waterfeaturesusa.com/pond-low-voltage-lighting.htm) [http://](http://waterfeaturesusa.com/pond-low-voltage-lighting.htm)  
[waterfeaturesusa.com/pond-low-voltage-lighting.htm](http://waterfeaturesusa.com/pond-low-voltage-lighting.htm), printed Mar. 11, 2009 (1 pg.).  
 Kichler LV Transformers at Internet website <http://www.elights.com/kictran.html>, printed Mar. 11, 2009 (3 pgs.).  
 Dabmar Transformers at Internet website <http://www.dabmar.com/CategoryProducts.aspx?Category+Transfoerms&CategoryID=17>, printed Mar. 11, 2009 (1 pg.).  
 Magcap Engineering Low Voltage Power Transformer at Internet website [http://www.magcap.com/newsite/product\\_tempalte.php?ID=19](http://www.magcap.com/newsite/product_tempalte.php?ID=19), printed Mar. 11, 2009 (1 pg.).  
 DIY Bench Power Supply, at Internet website <http://www.adwiens.com/projects/electronics/07/index.html>, printed Oct. 22, 2009 (4 pgs.).  
 Duellist International Ltd., London—Large Repeater Panel Display, at Internet website <http://www.duellist.com/cgi-bin/fencing.cgi?product=Scoring&pid=795>, printed Oct. 22, 2009 (1 pg.).  
 Endeavor 6KVA UPS LED/LCD Front Panel Display/Control, at Internet website <http://www.minutemanups.com/products/endeavor6kva.php>, printed Oct. 22, 2009 (1 pg.).  
 Digital panel meter at Internet website <http://www.directindustry.com/prod/crompton-instruments/digital-panel-meter-12296-60340.html>, printed Oct. 22, 2009 (1 pg.).  
 Kichler Lighting Transformer 200W Timer at Internet website <http://www.landscapelighting.com/portal/products/detail/15T200AZT>, printed Aug. 17, 2010 (1 pg.).  
 Kichler Lighting Transformer 200W Timer&Photo at Internet website <http://www.landscapelighting.com/portal/products/detail/15TP200AZT>, printed Aug. 17, 2010 (1 pg.).  
 Toroidal Magnetic Low Voltage Transformer 300W 12V AC at Internet website <http://www.pegasusassociates.com/magTransformer300W12V.html>, printed Aug. 17, 2010 (2 pgs.).

\* cited by examiner

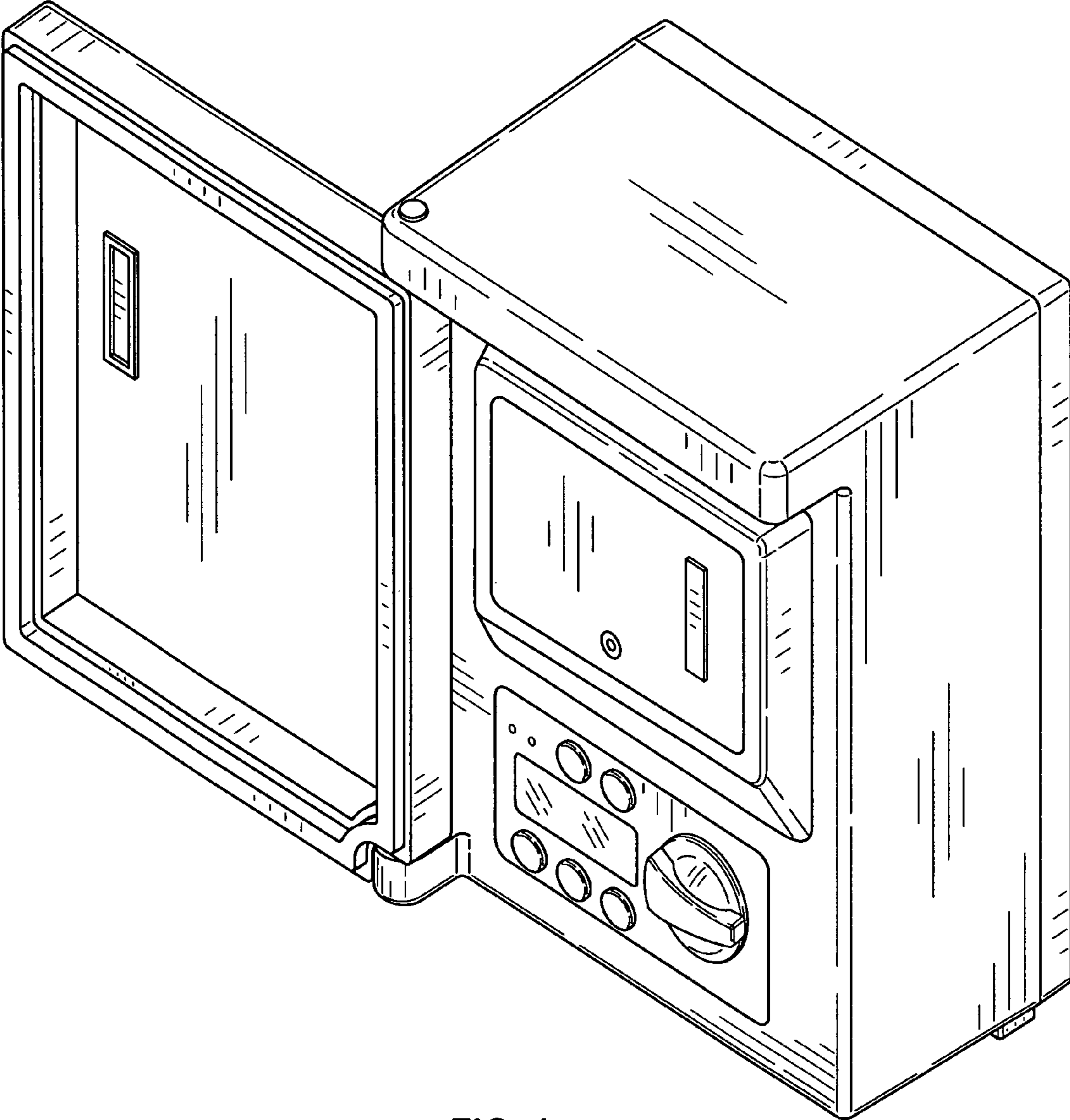

FIG. 1

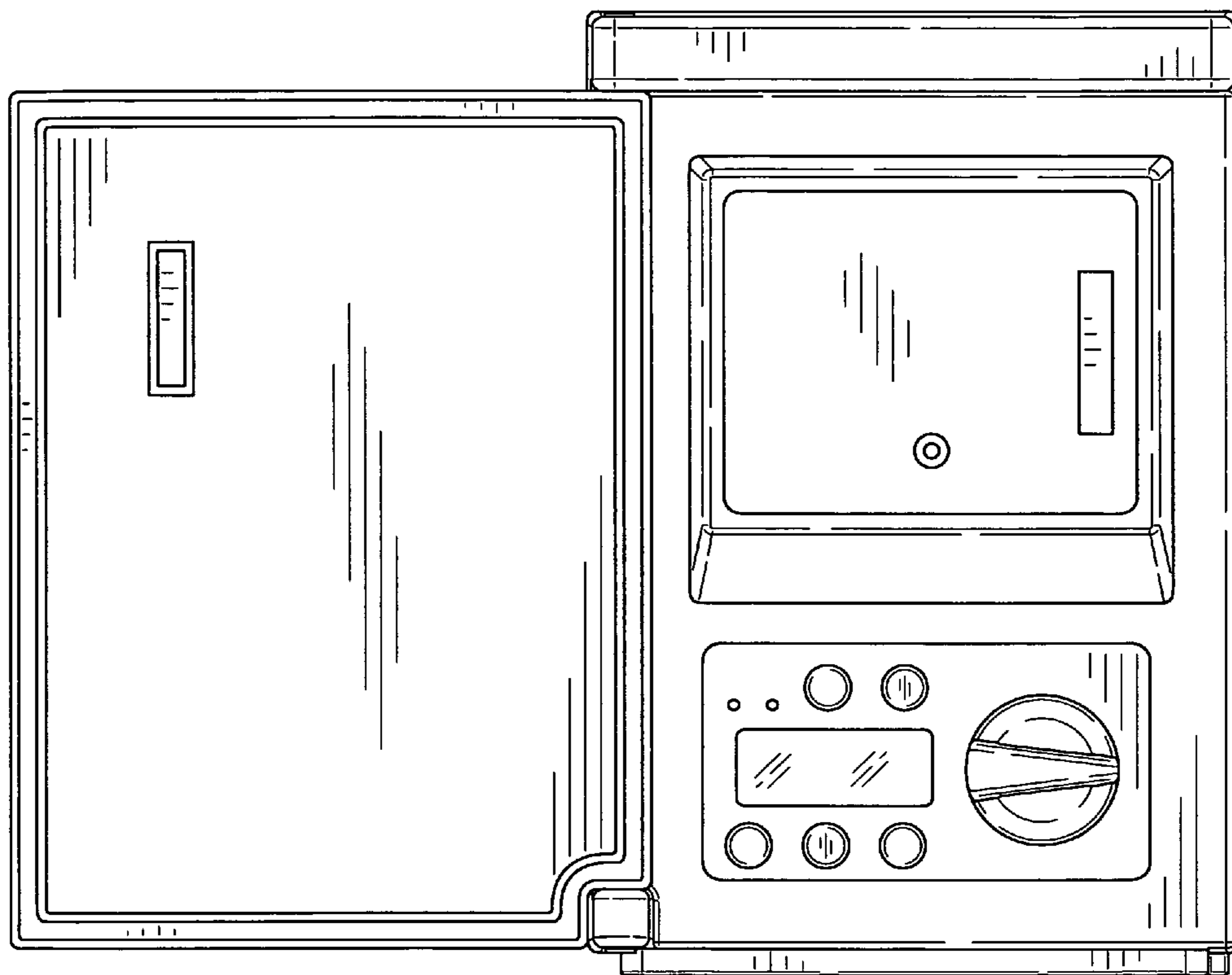

FIG. 2

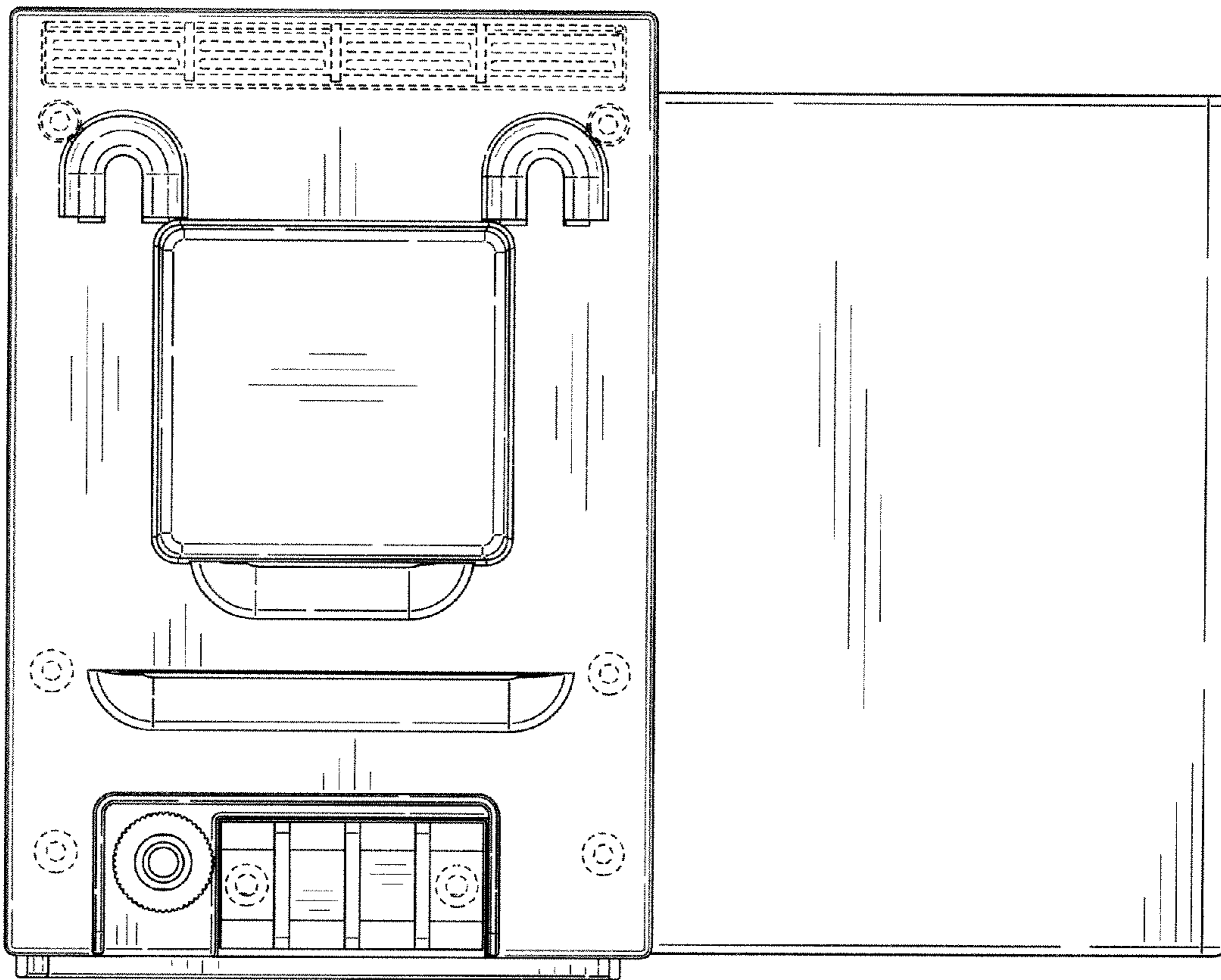

FIG. 3

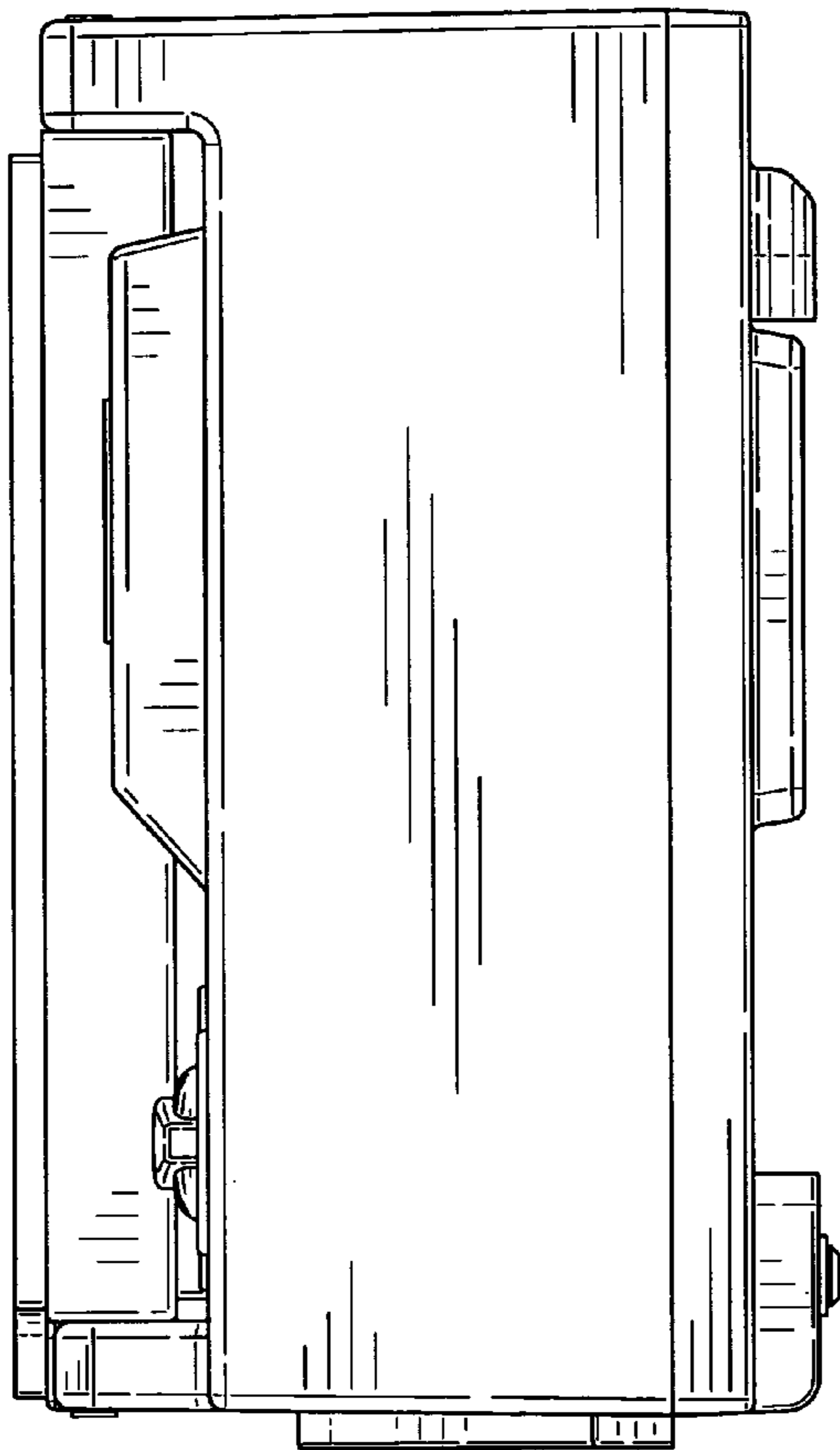

FIG. 4

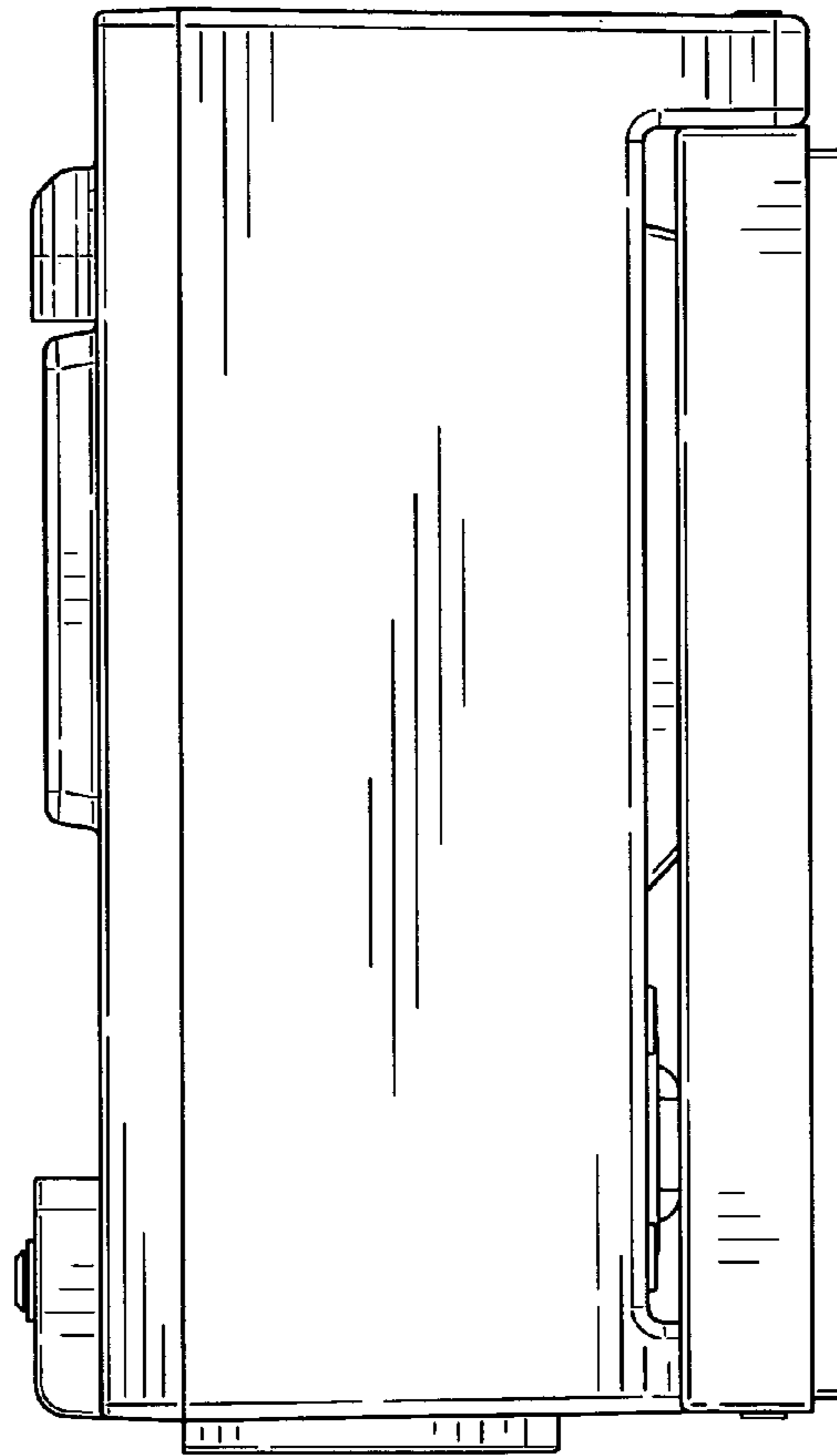

FIG. 5

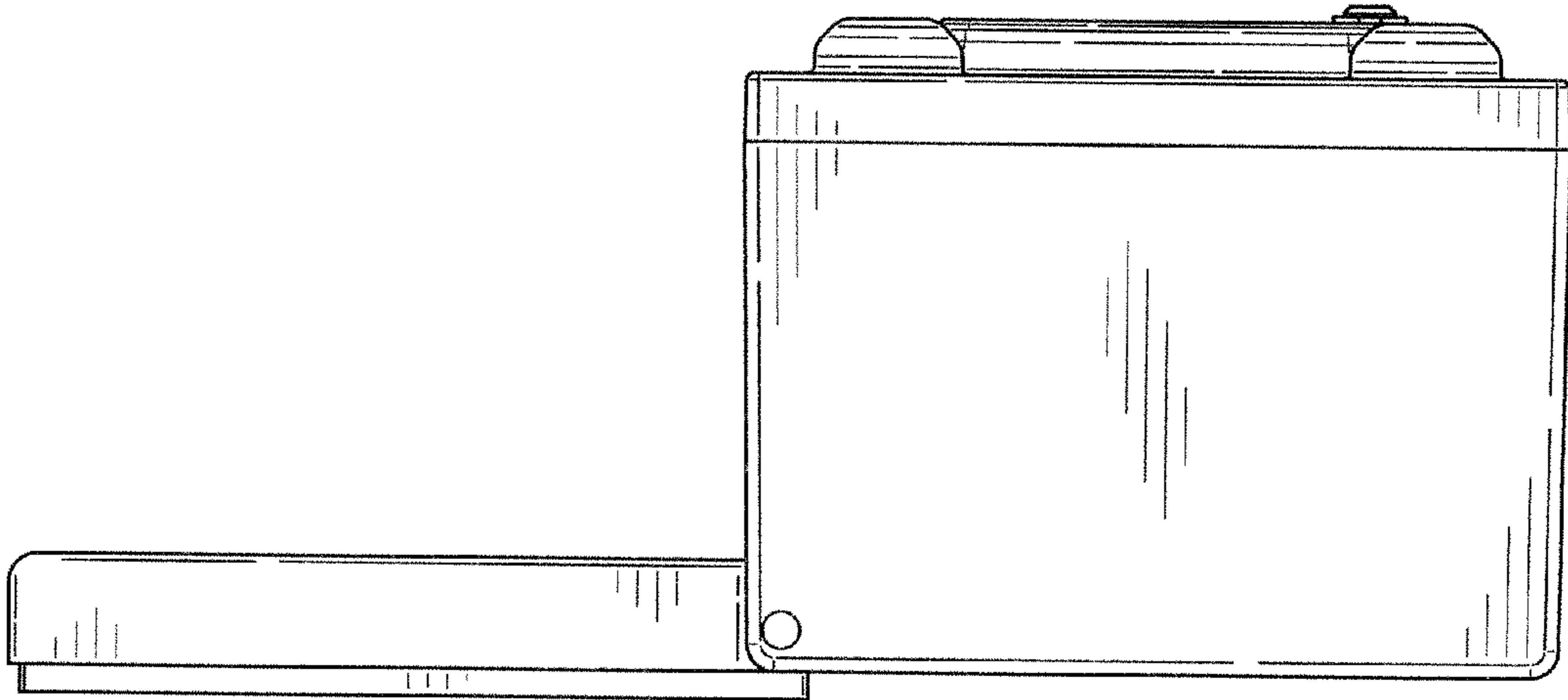

FIG. 6

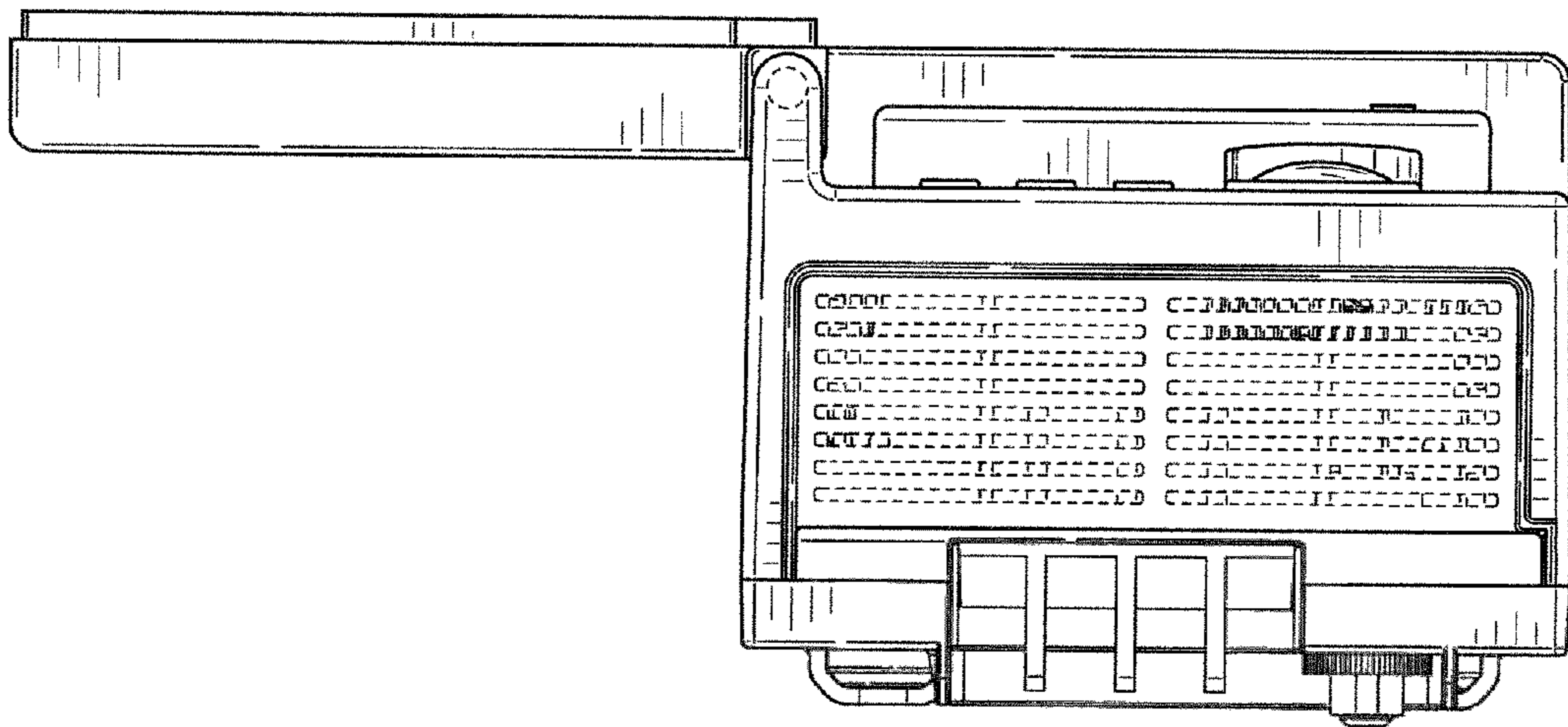

FIG. 7

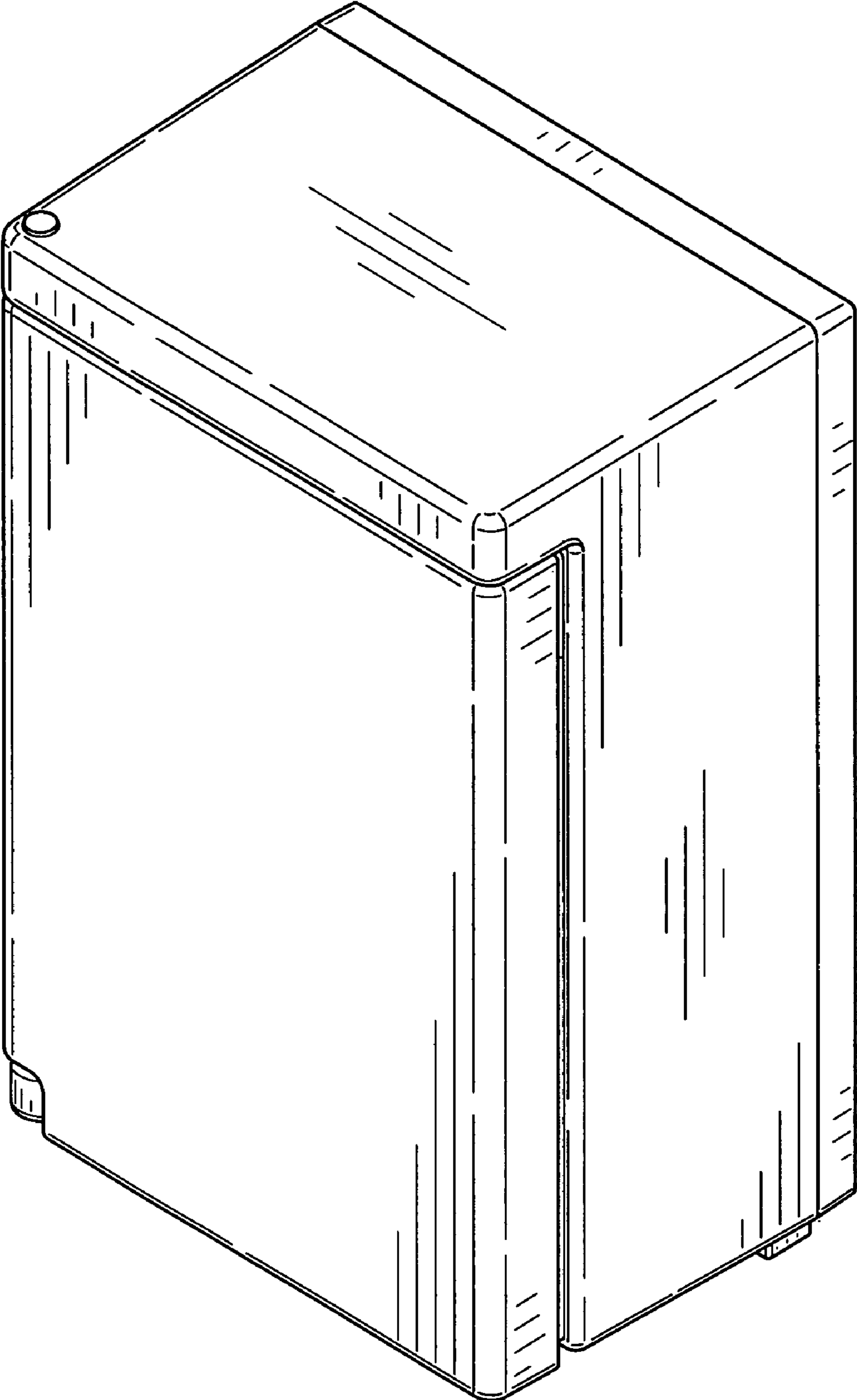

FIG. 8



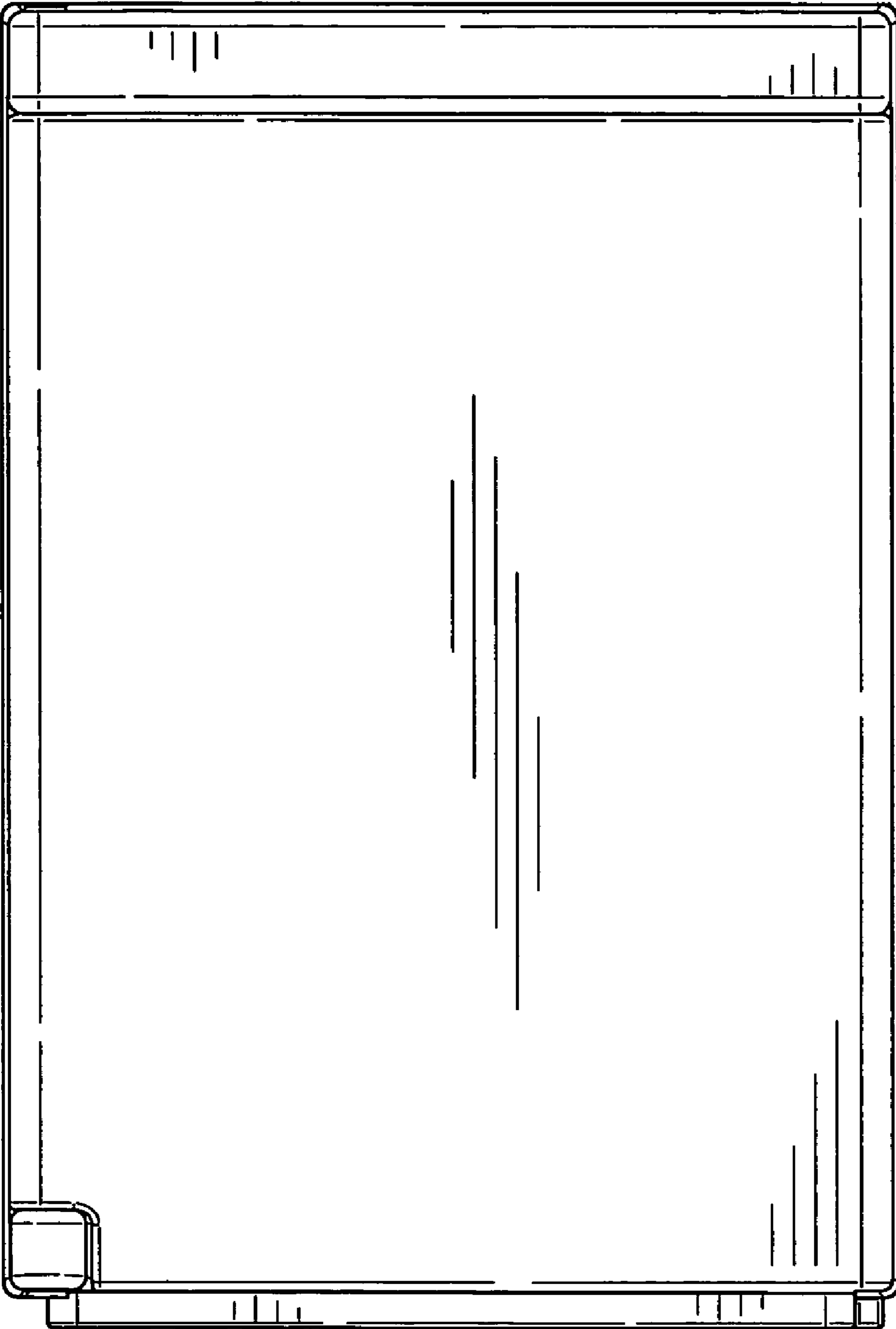

FIG. 9

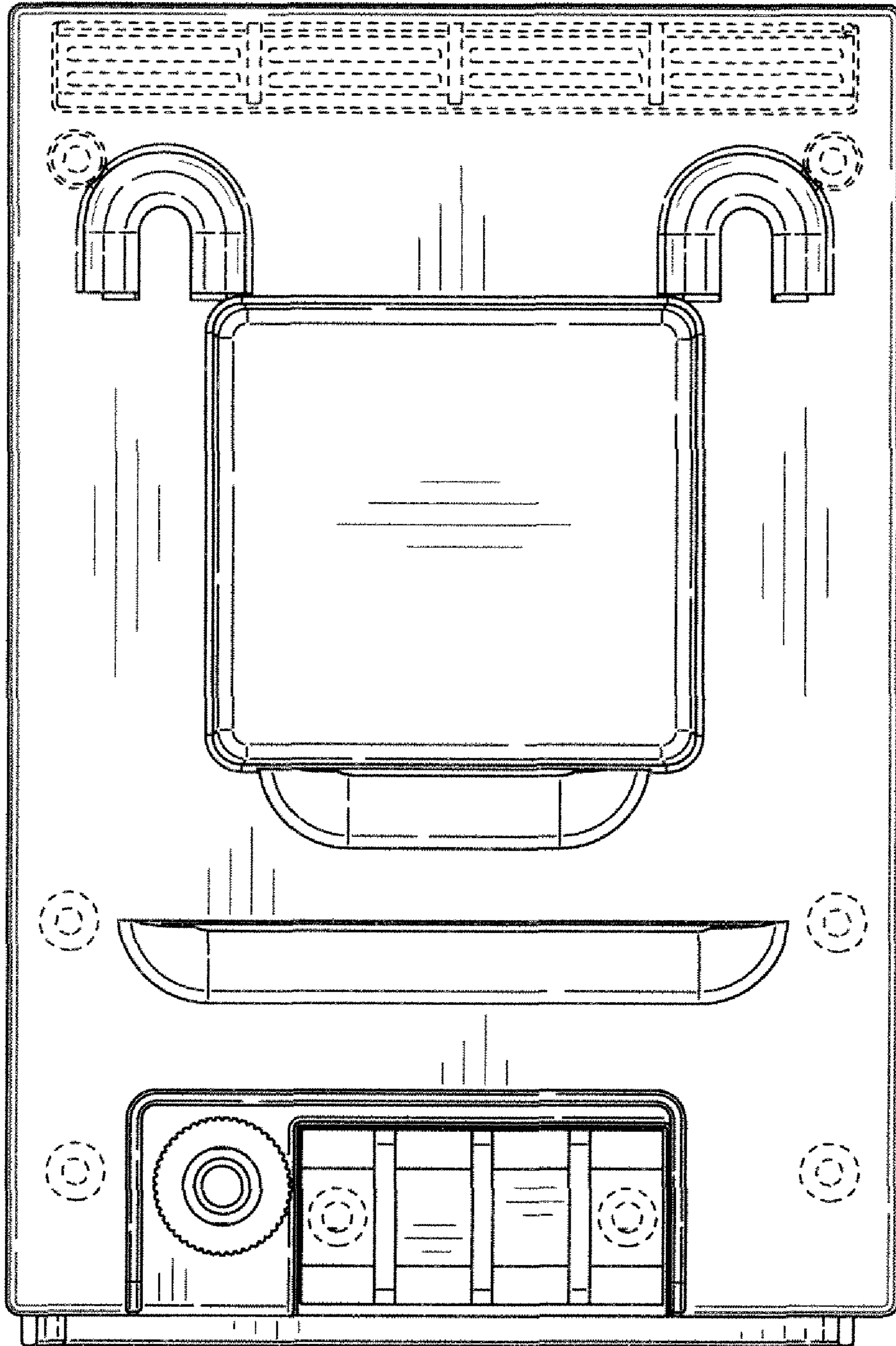

FIG. 10

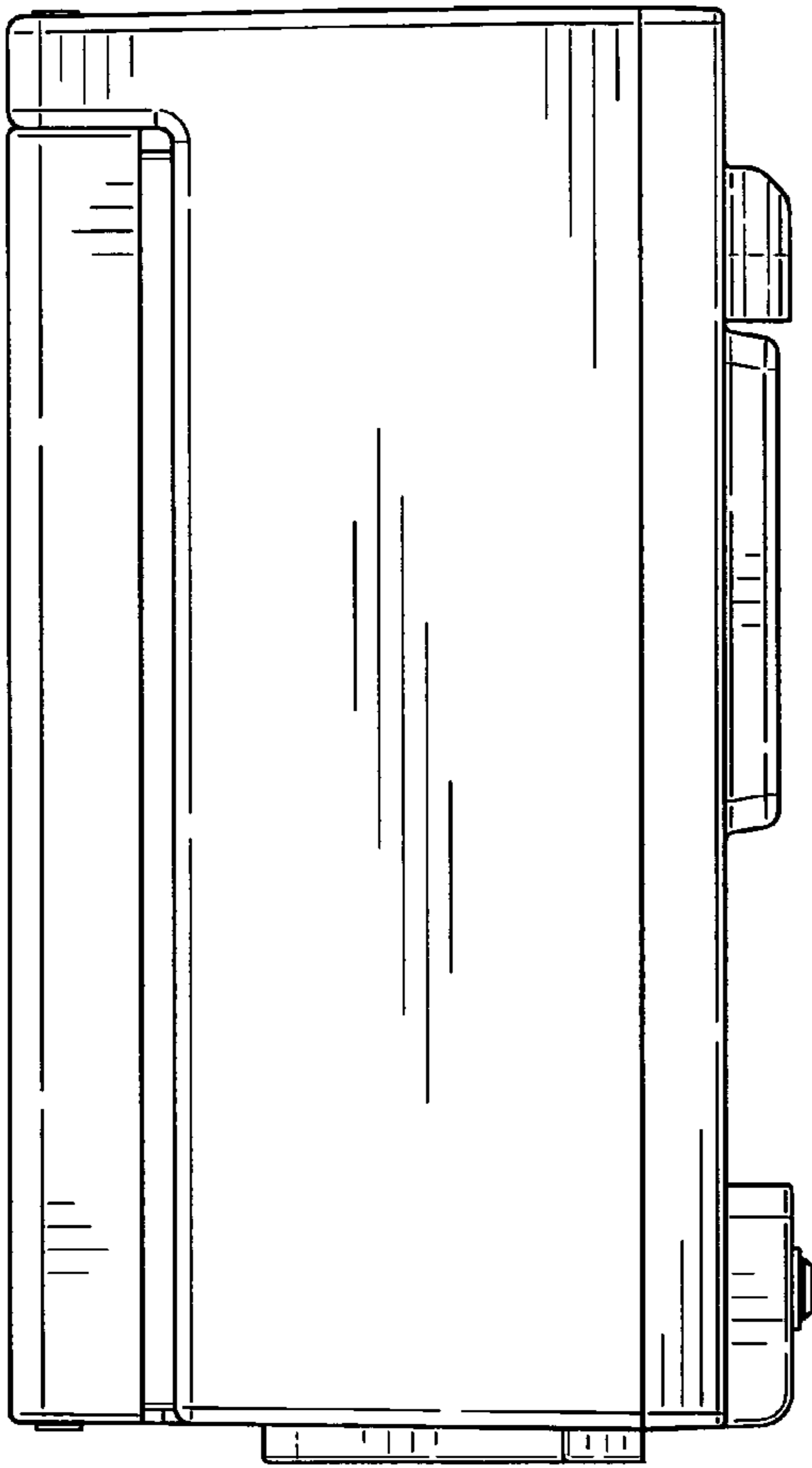

FIG. 11

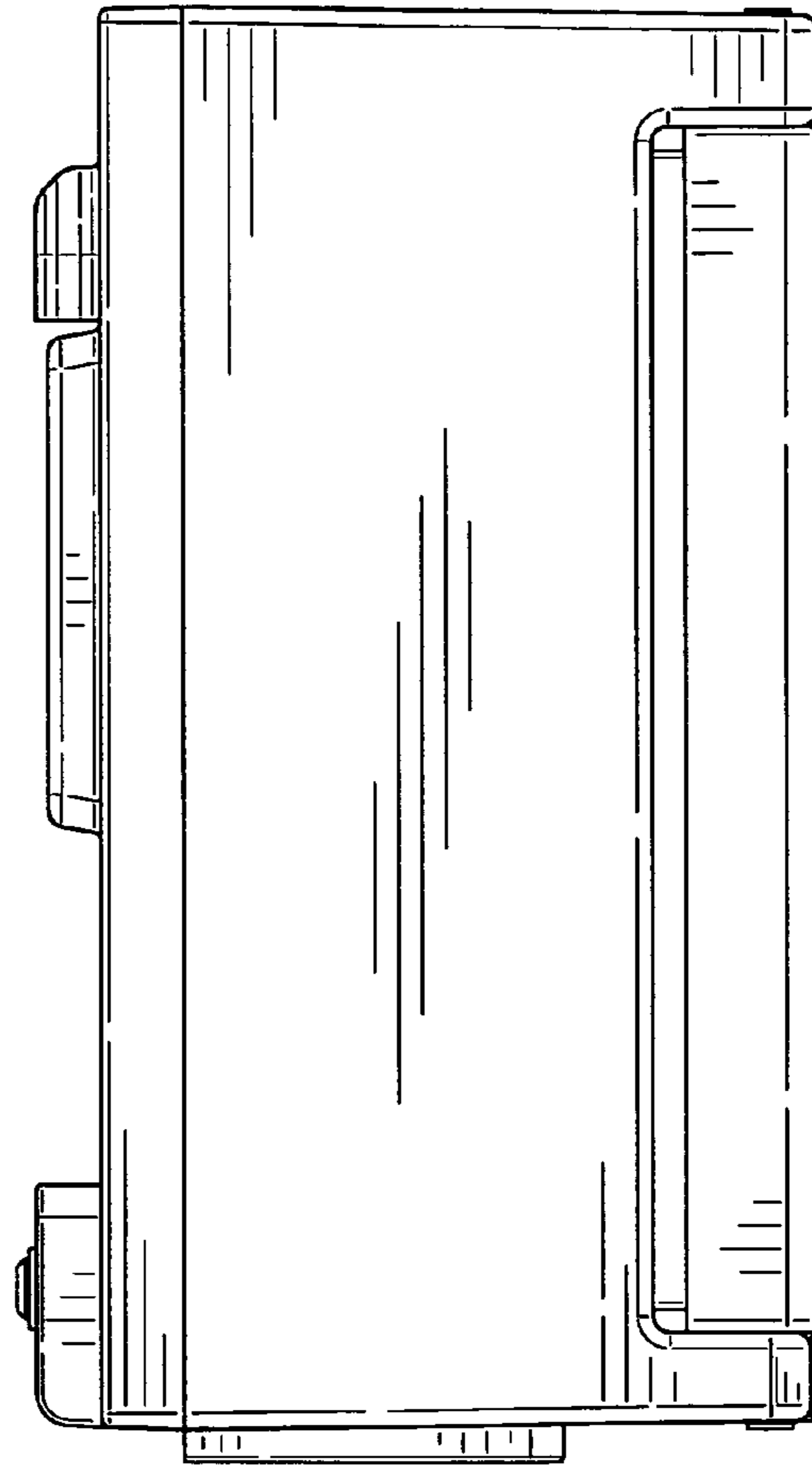

FIG. 12

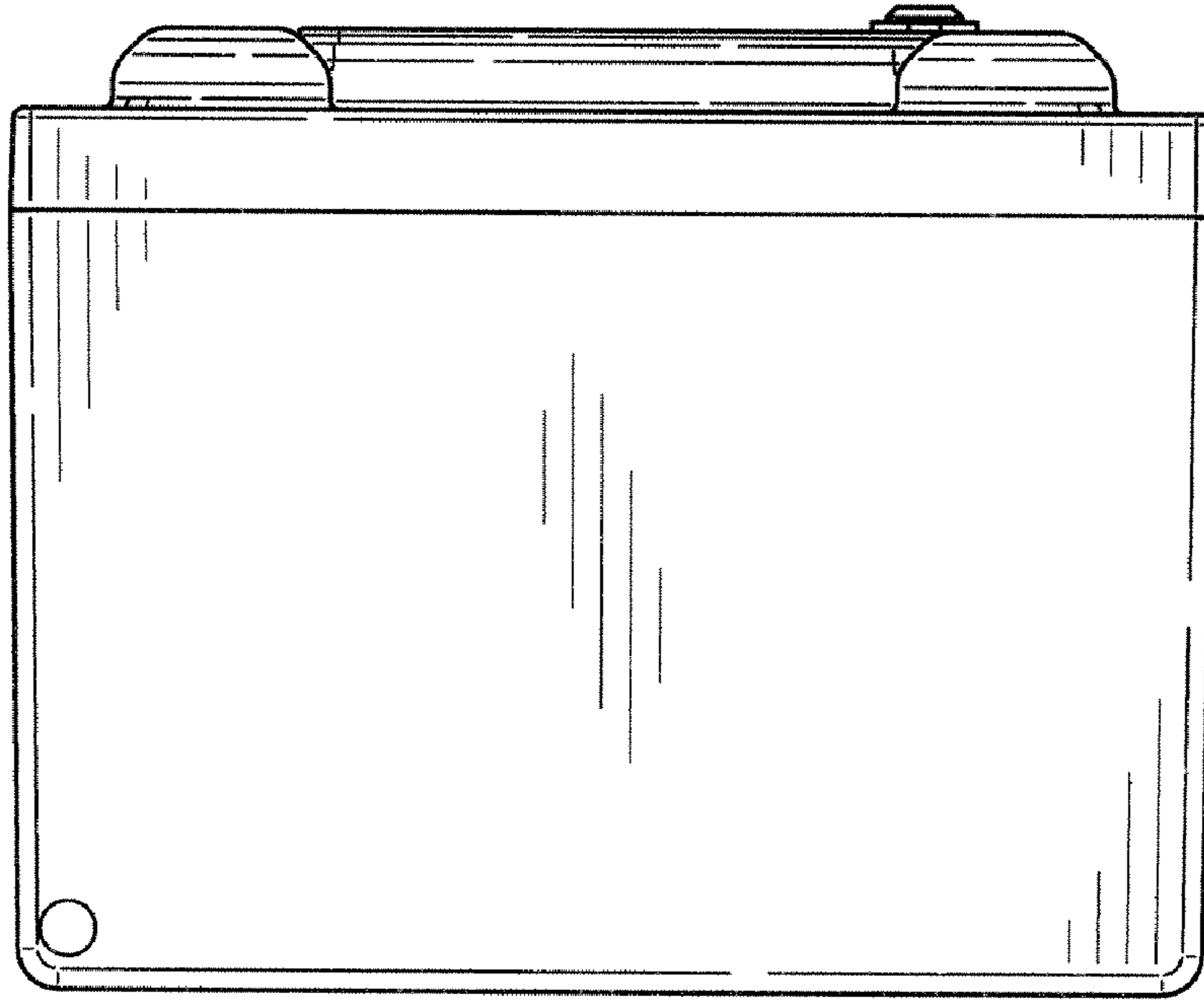

FIG. 13

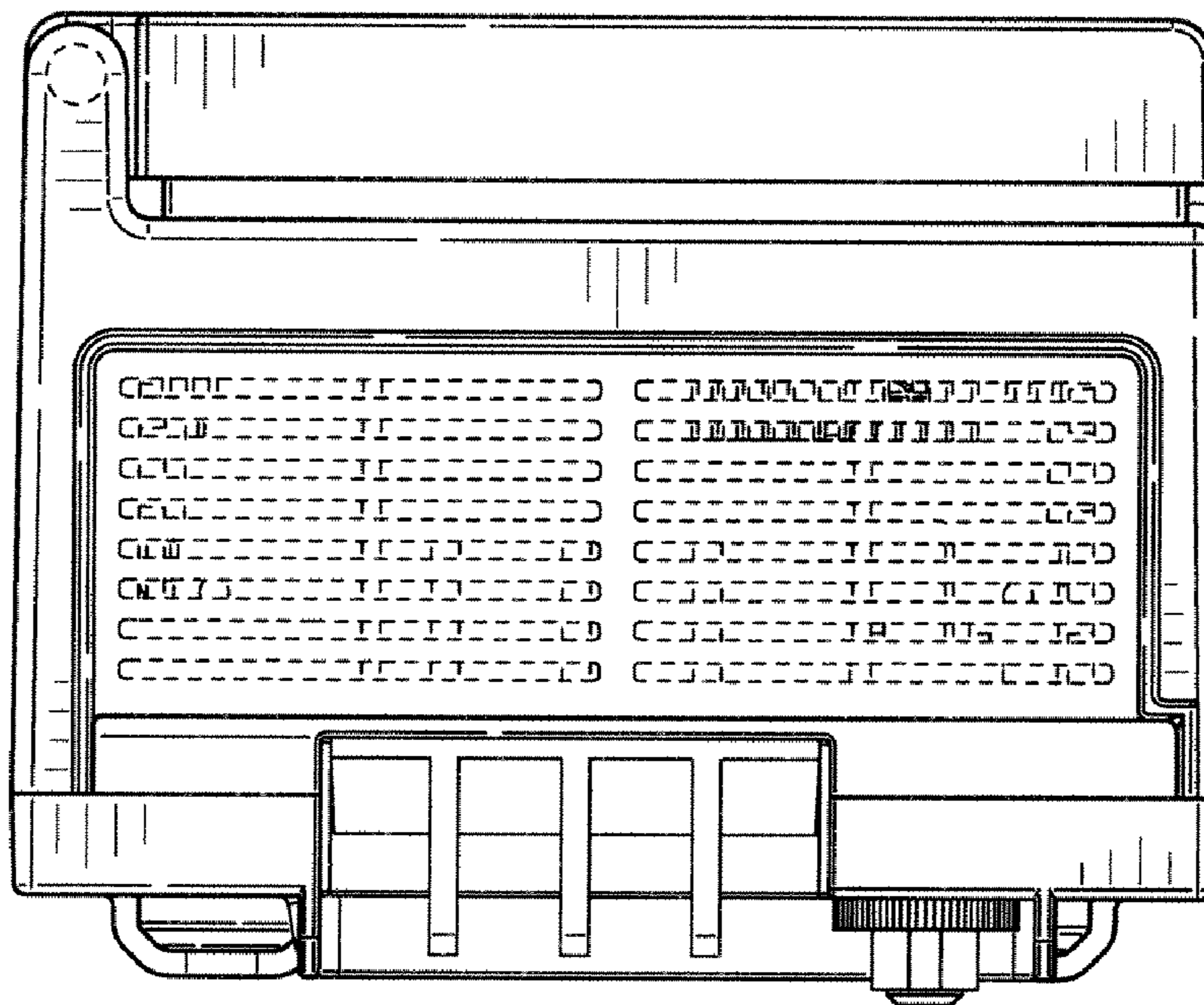

FIG. 14