



US00D633421S

(12) **United States Design Patent**  
**Peltola et al.**

(10) **Patent No.:** **US D633,421 S**  
(45) **Date of Patent:** **\*\* Mar. 1, 2011**

(54) **CENTER EXTENDER FOR REAR OF TRUCK ROOF**

D424,496 S 5/2000 Damon  
D424,999 S \* 5/2000 Carlson et al. .... D12/181  
D425,450 S 5/2000 Barraclough  
D431,511 S 10/2000 Damon

(75) Inventors: **Wallace A. Peltola**, Sammamish, WA (US); **Jonathan Duncan**, Seattle, WA (US); **Gerald J. Angelo**, Bellevue, WA (US); **Alec C. Wong**, Bellevue, WA (US); **Mark Dyal**, Renton, WA (US)

(Continued)

(73) Assignee: **PACCAR Inc**, Bellevue, WA (US)

*Primary Examiner*—Caron Veynar  
*Assistant Examiner*—Katrina A Kile

(\*\*) Term: **14 Years**

(74) *Attorney, Agent, or Firm*—Christensen O'Connor Johnson Kindness PLLC

(21) Appl. No.: **29/360,602**

(22) Filed: **Apr. 28, 2010**

(57) **CLAIM**

(51) **LOC (9) Cl.** ..... **12-08**

The ornamental design for a center extender for rear of truck roof, as shown and described.

(52) **U.S. Cl.** ..... **D12/181**

(58) **Field of Classification Search** ..... D12/181, D12/184, 191, 196, 400, 190, 88; 280/848, 280/770, 727; 296/91, 180.1–180.5; 180/903  
See application file for complete search history.

**DESCRIPTION**

(56) **References Cited**

U.S. PATENT DOCUMENTS

4,401,338 A	8/1983	Caldwell	
4,408,792 A	10/1983	Sullivan	
D271,191 S	* 11/1983	Amprim et al. ....	D12/181
D272,058 S	1/1984	Kangas	
D289,891 S	* 5/1987	Bielby .....	D12/190
D290,455 S	* 6/1987	Konen et al. ....	D12/181
D329,214 S	9/1992	Marlowe	
D341,563 S	* 11/1993	Niemi .....	D12/191
D356,770 S	* 3/1995	Almen .....	D12/181
D384,914 S	10/1997	Bingaman	
D385,223 S	10/1997	Marlowe	
D399,465 S	* 10/1998	Saleen .....	D12/190
D400,158 S	10/1998	Meryman	
D403,638 S	* 1/1999	Boniface et al. ....	D12/181
D403,999 S	* 1/1999	Lund .....	D12/191
D409,541 S	* 5/1999	Sproull et al. ....	D12/191
D422,957 S	4/2000	Damon	
D424,489 S	5/2000	Damon	
D424,495 S	5/2000	Damon	

FIG. 1 is a rear perspective view of a center extender for rear of truck roof showing our new design;

FIG. 2 is a rear elevational view of the center extender for rear of truck roof of FIG. 1;

FIG. 3 is a front elevational view of the center extender for rear of truck roof of FIG. 1;

FIG. 4 is a top plan view of the center extender for rear of truck roof of FIG. 1;

FIG. 5 is a bottom plan view of the center extender for rear of truck roof of FIG. 1; and,

FIG. 6 is a left side elevational view of the center extender for rear of truck roof of FIG. 1, the right side elevational view being mirror symmetrical to FIG. 6.

The broken line showing of a portion of a truck roof is for the purpose of illustrating environmental structure and forms no part of the claimed design.

**1 Claim, 3 Drawing Sheets**

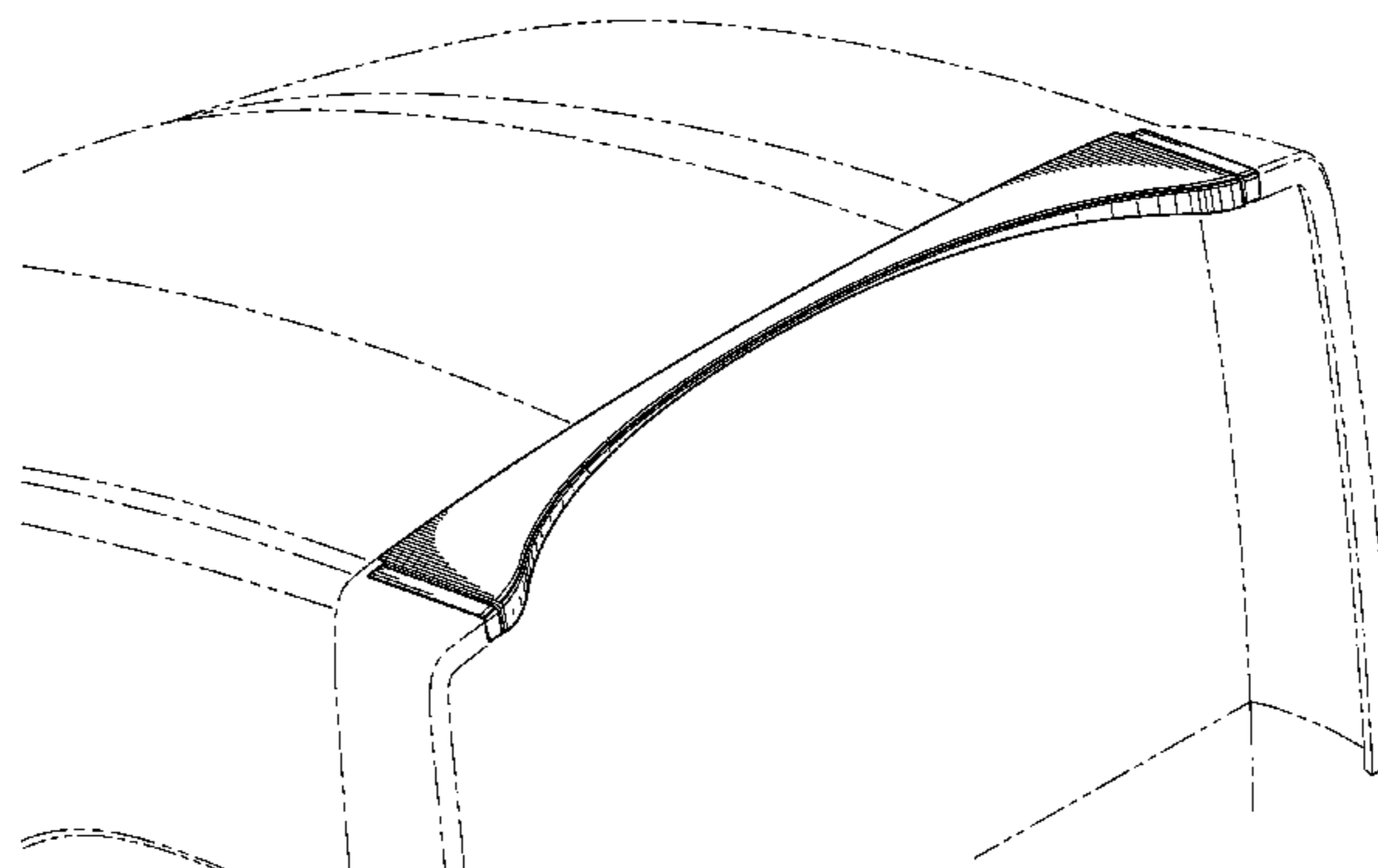

# US D633,421 S

Page 2

---

## U.S. PATENT DOCUMENTS

D434,347 S 11/2000 Damon  
D436,335 S 1/2001 Beigel  
D436,894 S 1/2001 Barraclough

D519,891 S \* 5/2006 Lai ..... D12/181  
D535,597 S 1/2007 Herpel  
D567,156 S \* 4/2008 Hutchins ..... D12/169  
D603,315 S \* 11/2009 Gamou ..... D12/190  
\* cited by examiner

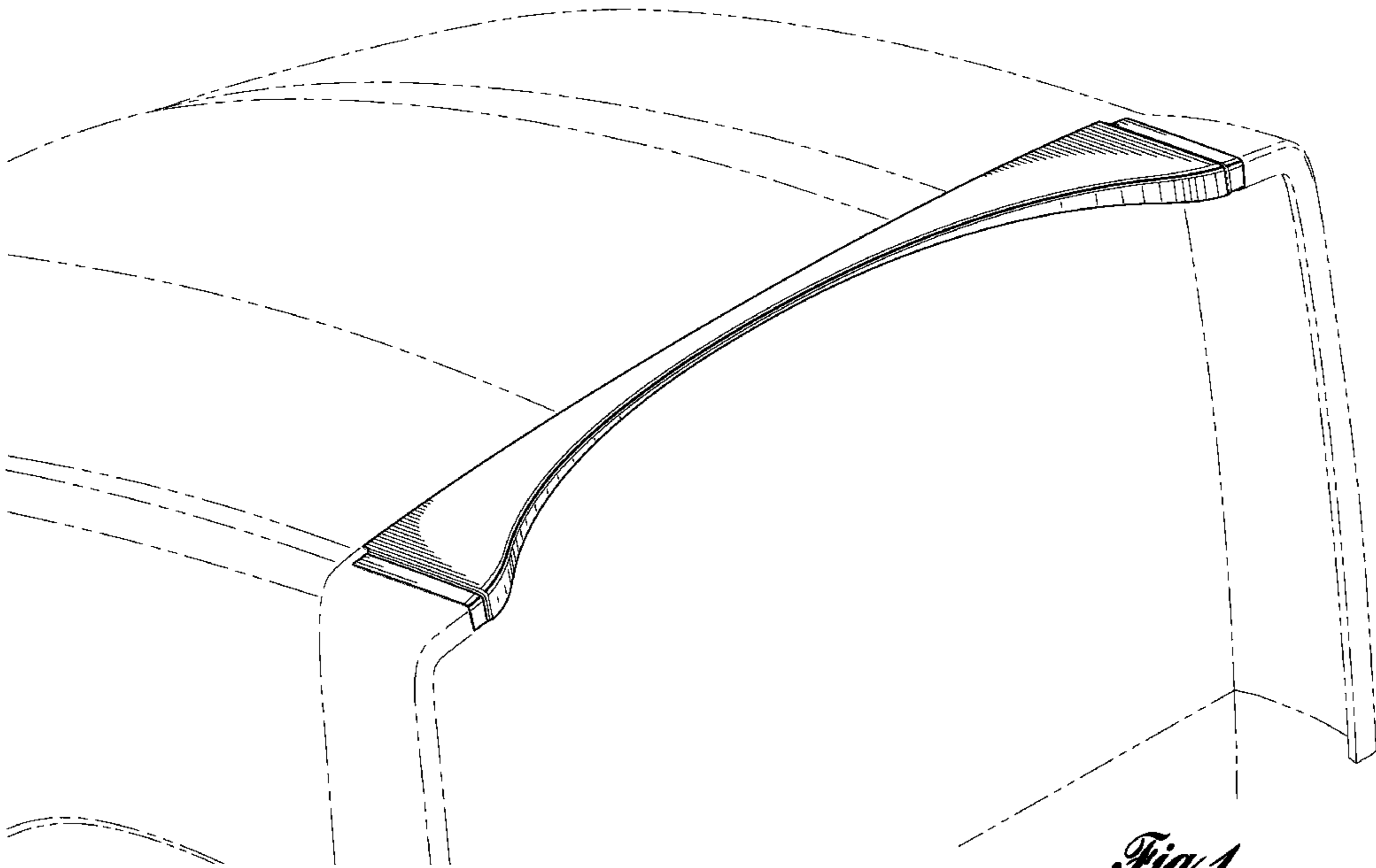

*Fig. 1.*



*Fig. 2.*

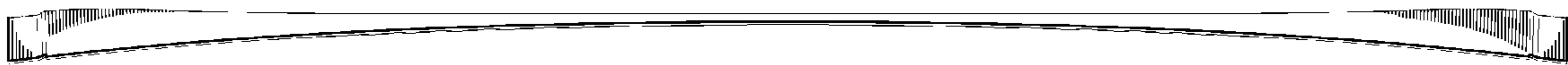

*Fig. 3.*

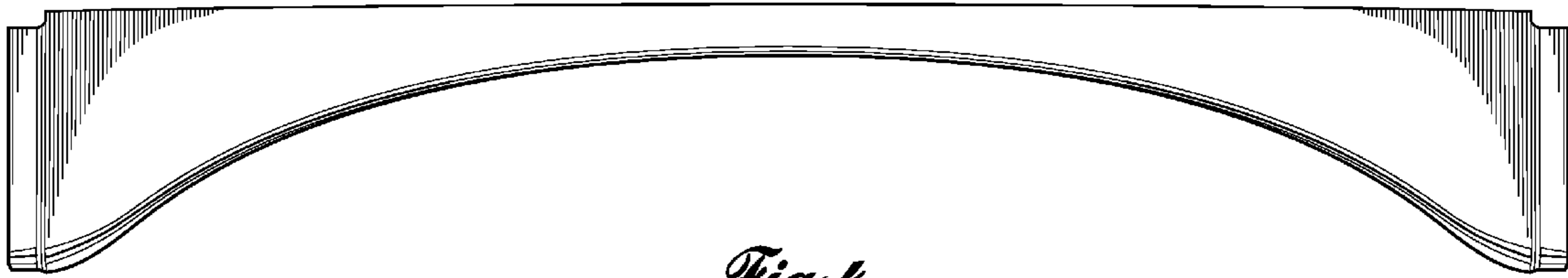

*Fig. 4.*



*Fig. 6.*

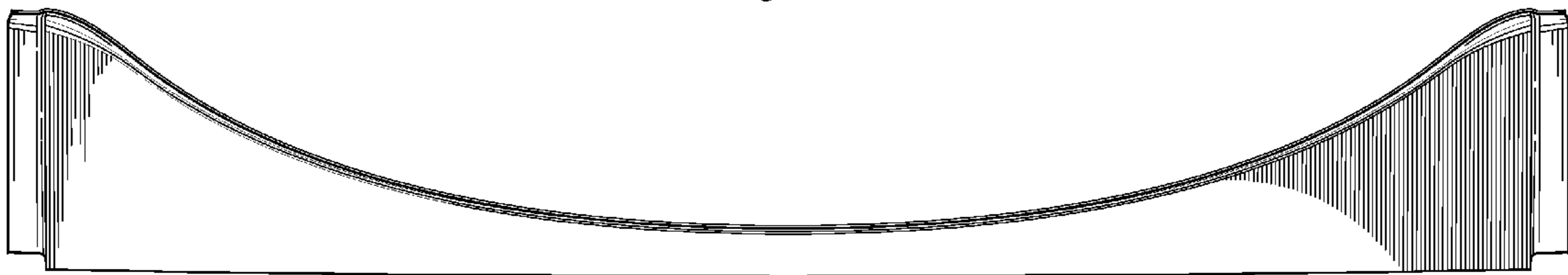

*Fig. 5.*