

US00D633219S

(12) **United States Design Patent**
Lai

(10) **Patent No.:** **US D633,219 S**

(45) **Date of Patent:** **** Feb. 22, 2011**

(54) **ASSEMBLED FLOOR MODULE**

(57) **CLAIM**

(76) **Inventor:** **Ying-Kuang Lai**, Luwu Industrial Zone,
Zengbu, Chashan Town, Dongguan,
Guangdong (CN)

The ornamental design for an assembled floor module, as
shown and described.

(**) **Term:** **14 Years**

DESCRIPTION

(21) **Appl. No.:** **29/330,948**

FIG. 1 is a front view of an assembled floor module showing
my new design;

(22) **Filed:** **Jan. 16, 2009**

FIG. 2 is a back view thereof;

(51) **LOC (9) Cl.** **25-01**

FIG. 3 is a left side view thereof;

(52) **U.S. Cl.** **D25/138**

FIG. 4 is a right side view thereof;

(58) **Field of Classification Search** D25/138;
52/390, 392, 403.1, 314; 428/49, 50, 52

FIG. 5 is a top view thereof;

See application file for complete search history.

FIG. 6 is a bottom view thereof;

FIG. 7 is a perspective view thereof;

(56) **References Cited**

FIG. 8 is an enlarged perspective view showing the left front
corner in the FIG. 7;

U.S. PATENT DOCUMENTS

FIG. 9 is an enlarged perspective view showing the right front
corner in the FIG. 7; and,

6,311,443	B1 *	11/2001	Allazetta	52/392
D462,130	S *	8/2002	Kotler	D25/163
6,694,689	B1 *	2/2004	Scott et al.	52/392
D555,813	S *	11/2007	Herdal	D25/138

FIG. 10 is a perspective view showing the assemblage of the
assembled floor module.

* cited by examiner

The assembled floor modules shown by broken lines are for
the purpose of illustrating that form no part of the claimed
design.

Primary Examiner—Doris Clark
(74) *Attorney, Agent, or Firm*—Global IP Services; Tianhua
Gu

1 Claim, 6 Drawing Sheets

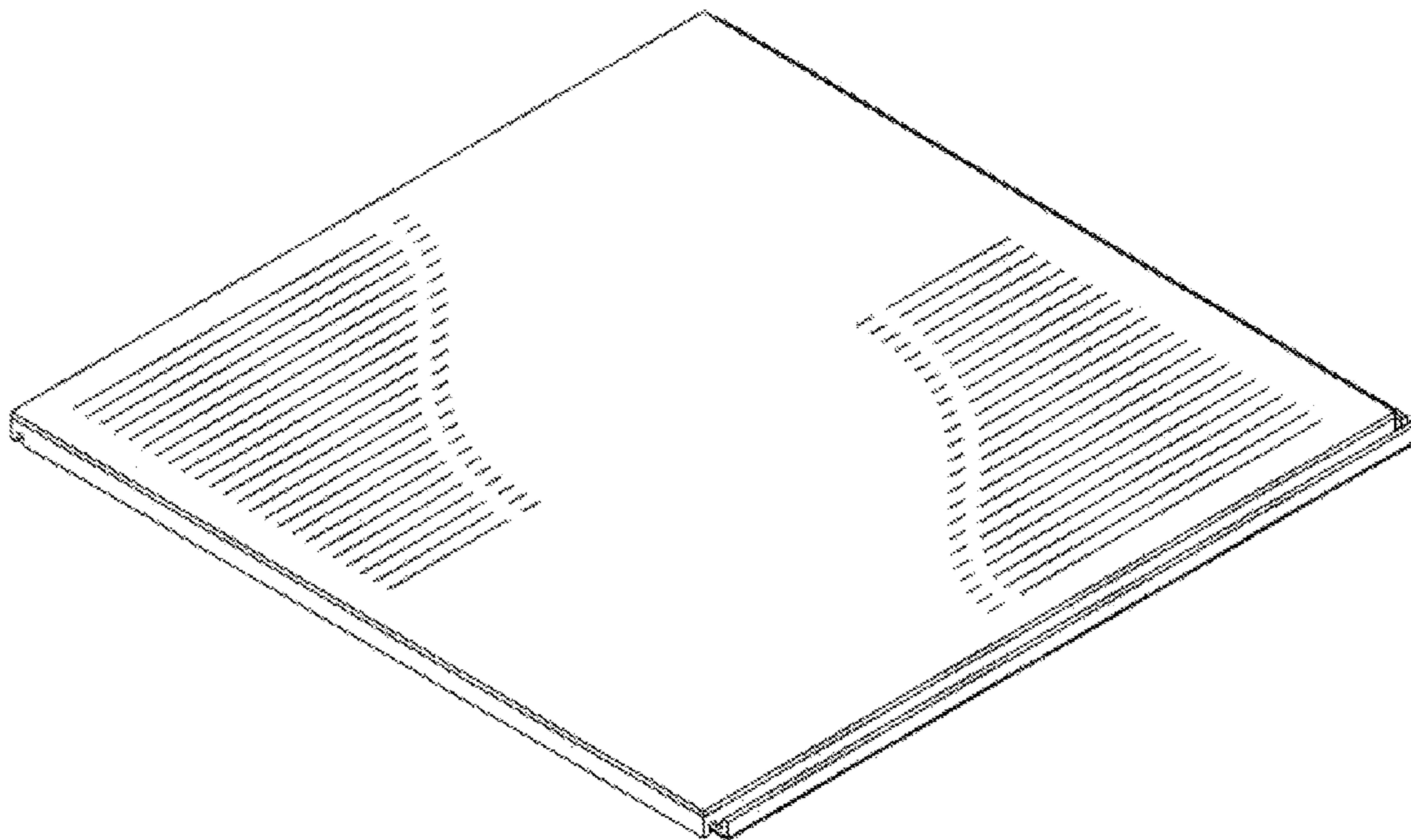

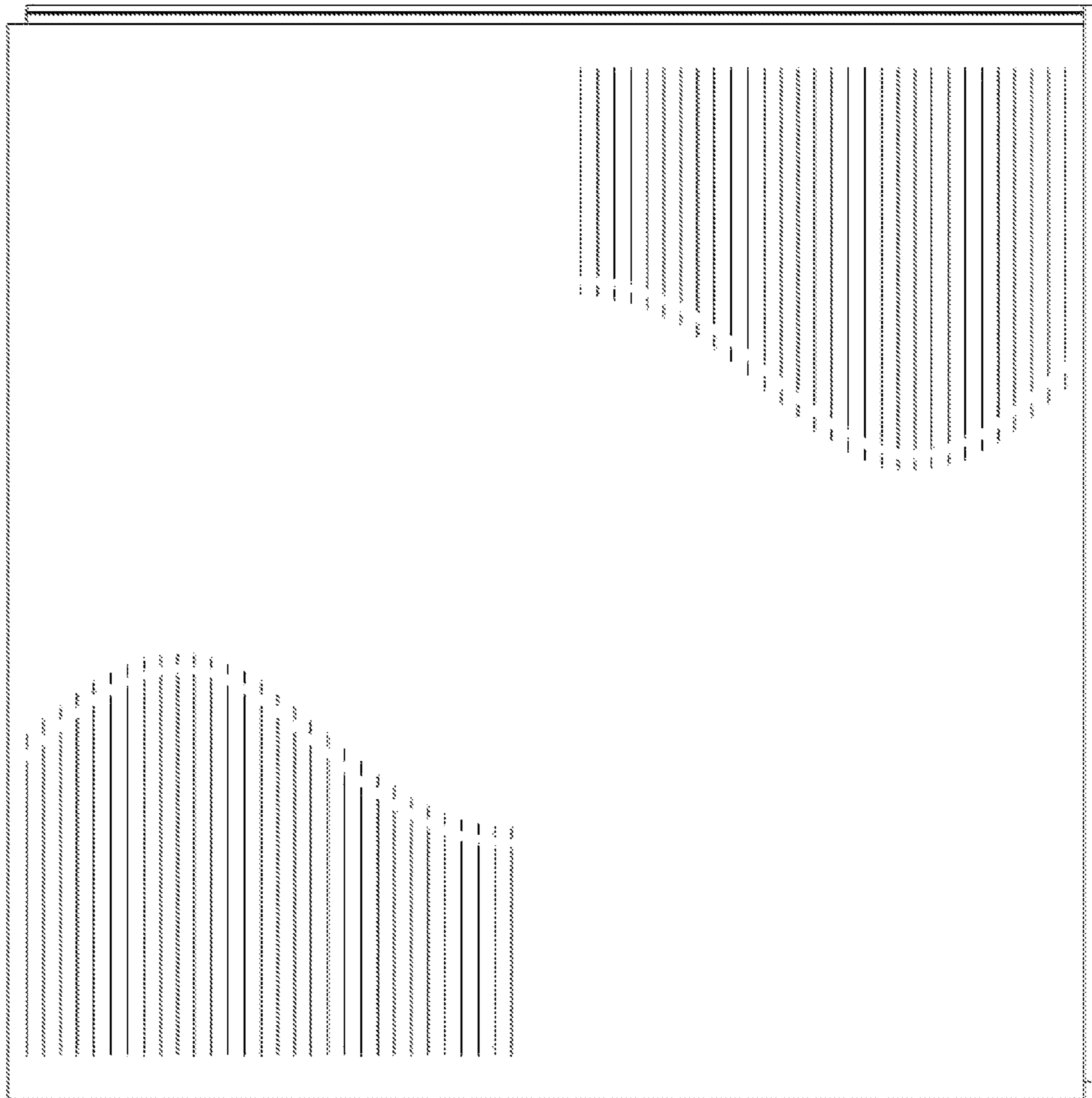

Fig. 1

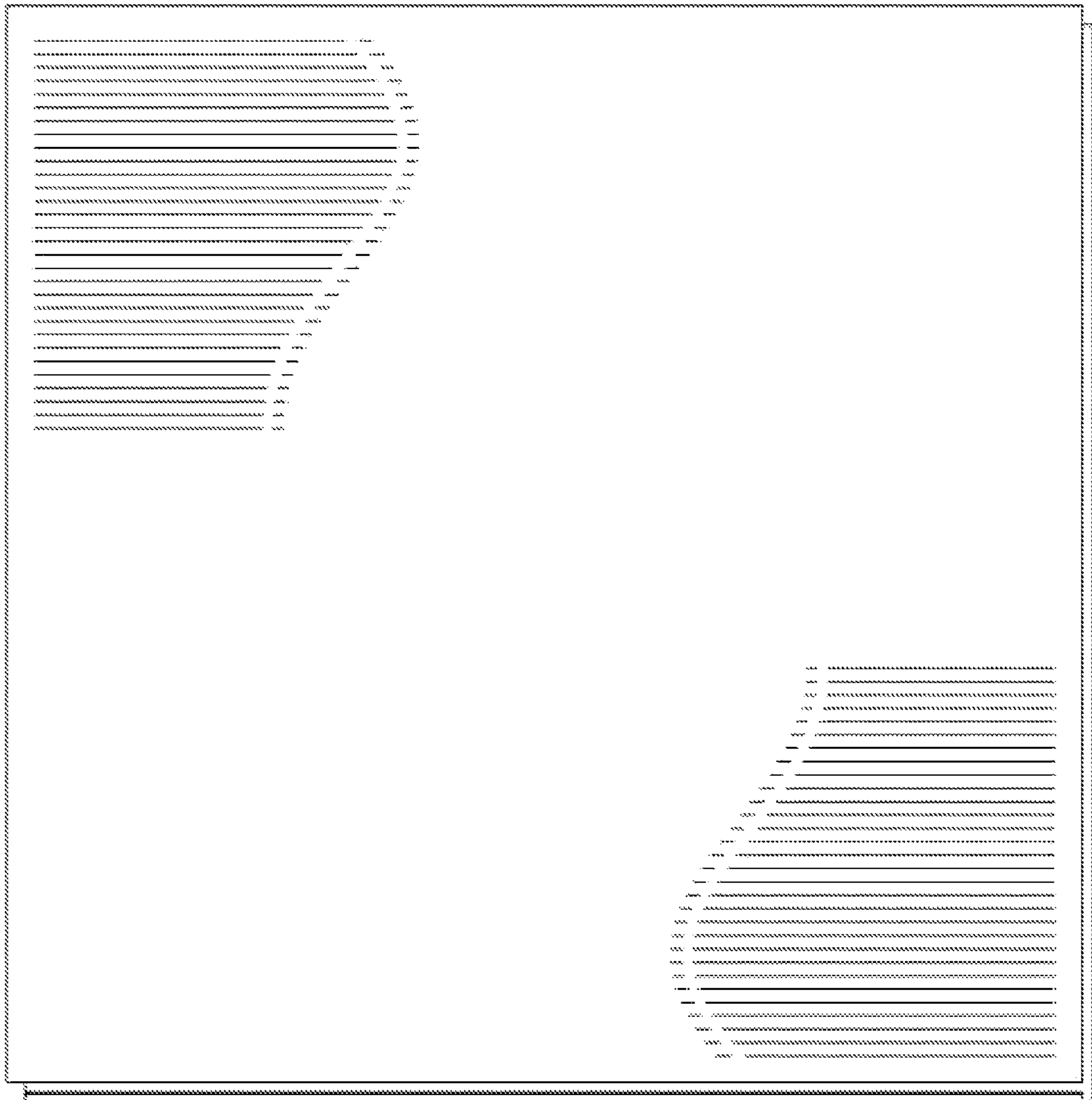

Fig. 2

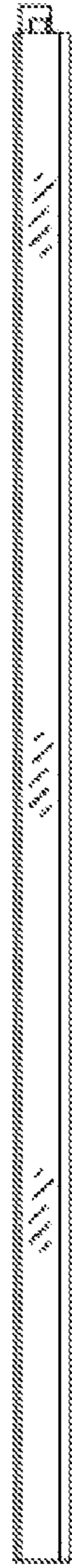

Fig. 3



Fig. 4

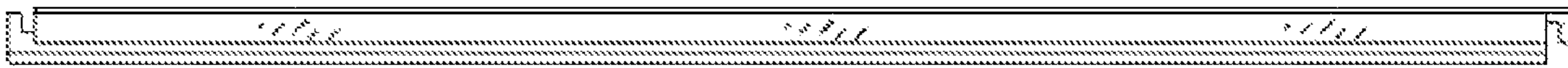

Fig. 5



Fig. 6

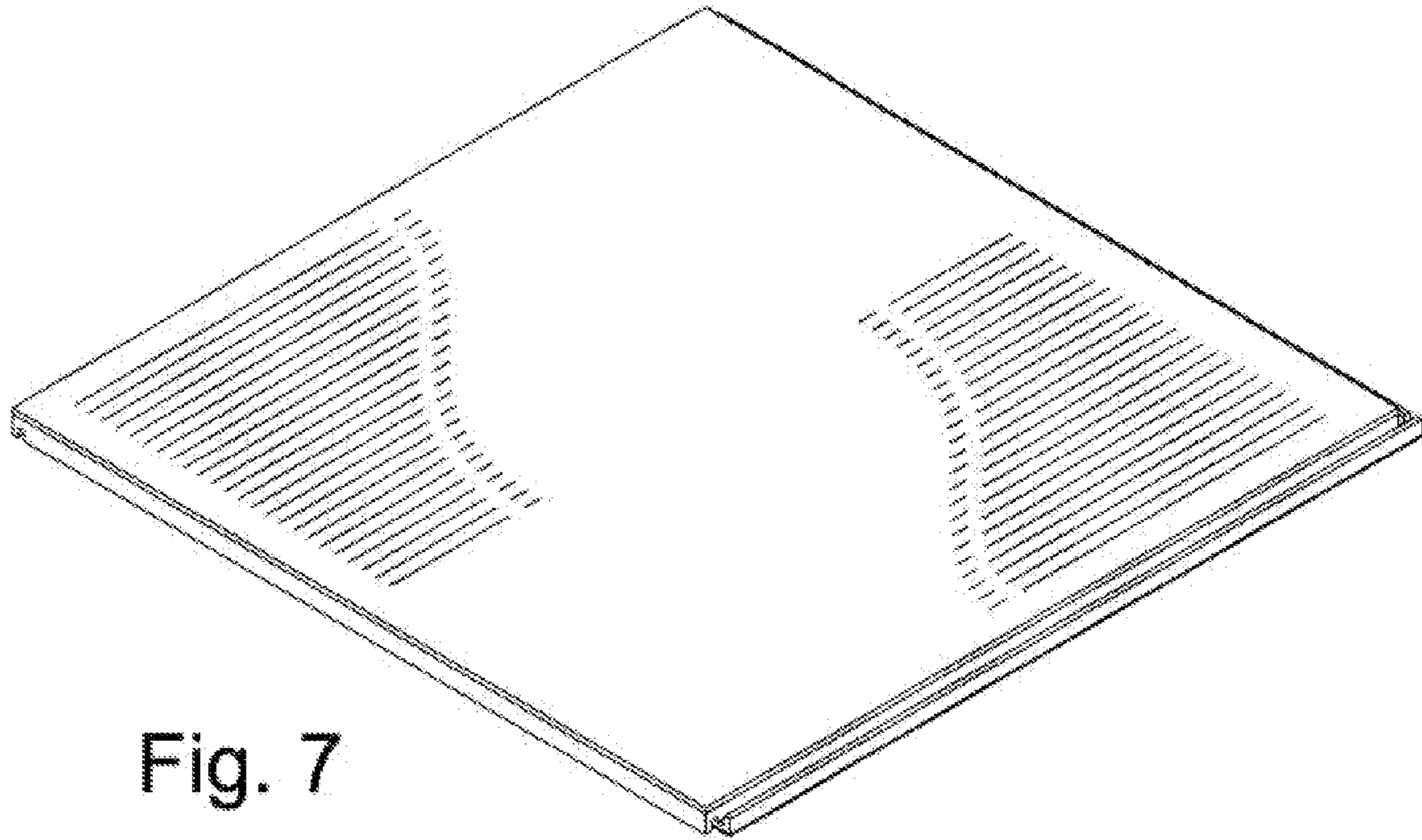

Fig. 7

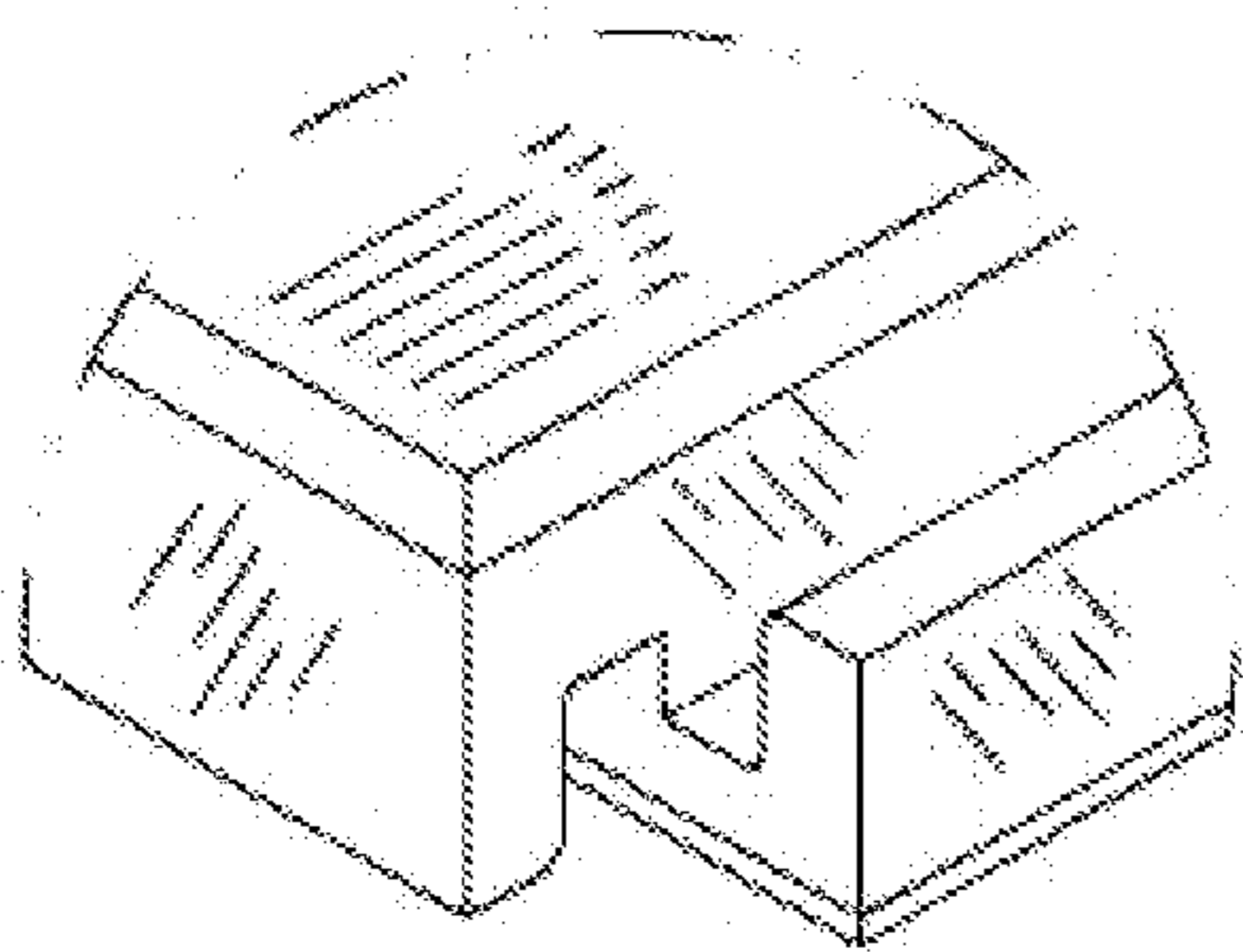

Fig. 8

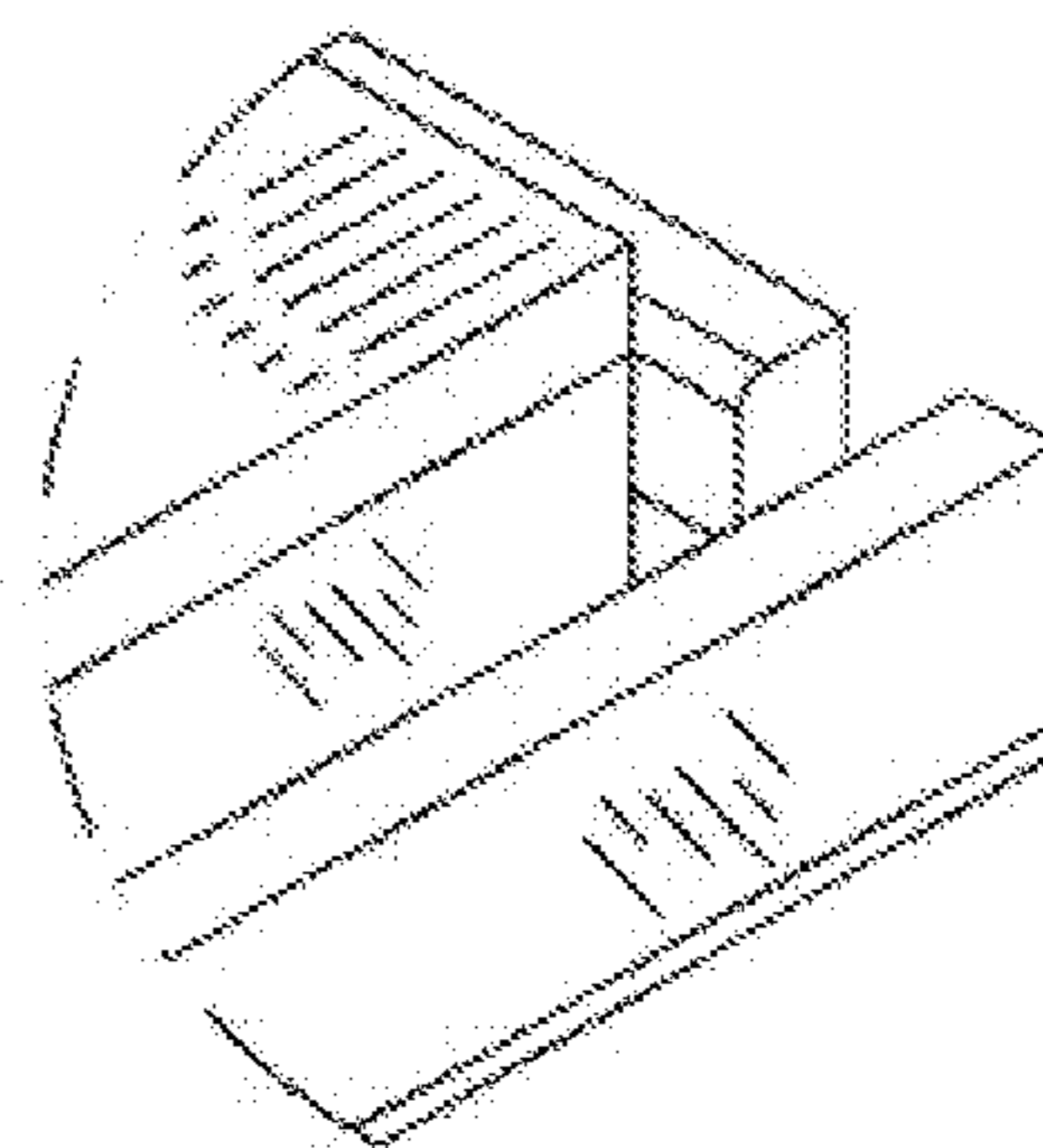

Fig. 9

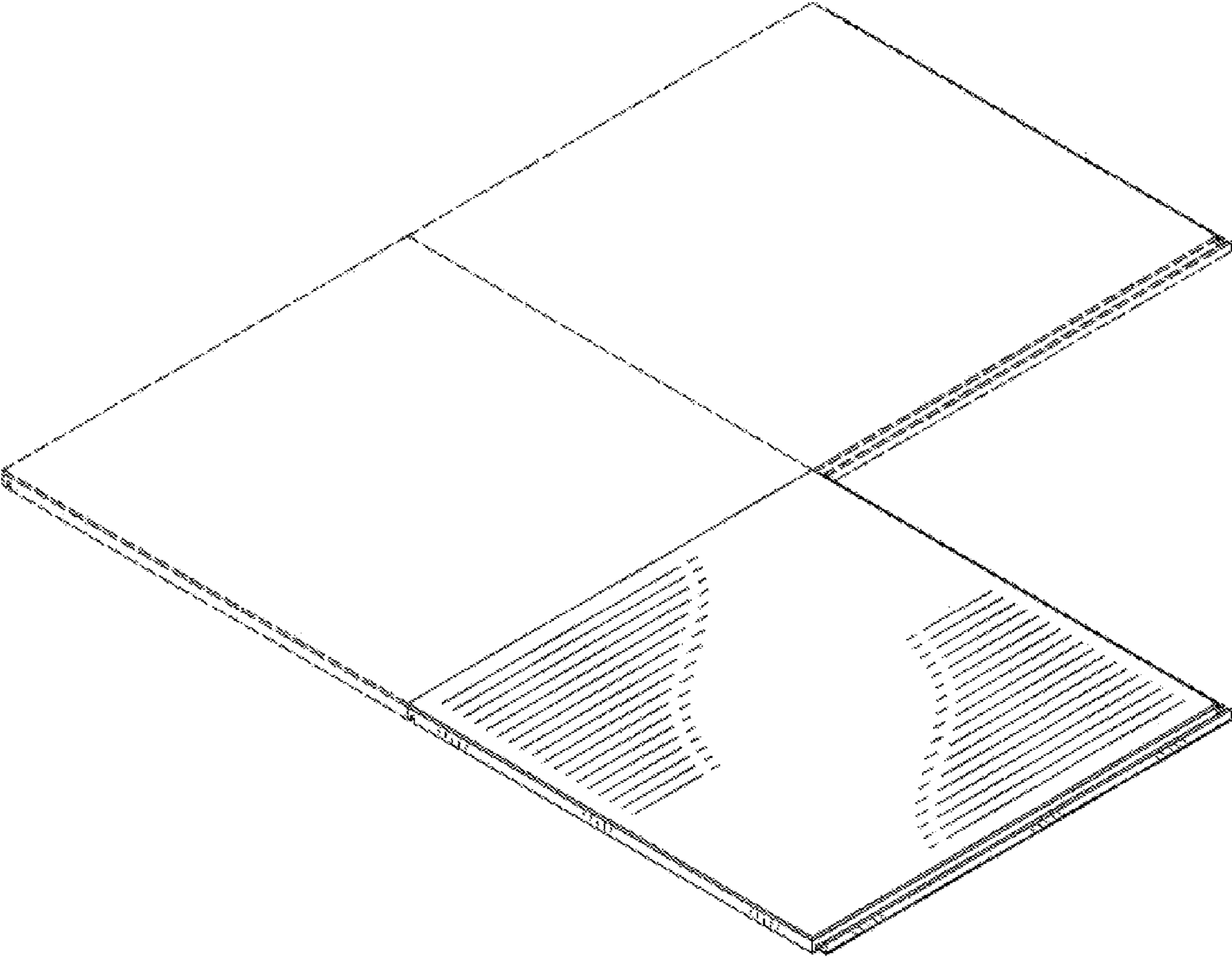

Fig. 10