



US00D633008S

(12) **United States Design Patent**  
**Nakamura et al.**

(10) **Patent No.:** **US D633,008 S**  
(45) **Date of Patent:** **\*\* Feb. 22, 2011**

(54) **AUTOMOBILE AND/OR REPLICA THEREOF**

(75) Inventors: **Keisuke Nakamura**, Saitama (JP);  
**Takeshi Aoki**, Saitama (JP)

(73) Assignee: **Honda Motor Co., Ltd.**, Tokyo (JP)

(\*\*) Term: **14 Years**

(21) Appl. No.: **29/364,498**

(22) Filed: **Jun. 24, 2010**

(30) **Foreign Application Priority Data**

Dec. 25, 2009 (JP) ..... 2009-030283

(51) **LOC (9) Cl.** ..... **12-08**

(52) **U.S. Cl.** ..... **D12/90**

(58) **Field of Classification Search** ..... D12/86,  
D12/90-92; D21/424, 433, 434; 296/181.1,  
296/181.5

See application file for complete search history.

(56) **References Cited**

**U.S. PATENT DOCUMENTS**

D597,443 S \* 8/2009 Vermeersch et al. .... D12/91

D607,778 S \* 1/2010 Ramaciotti ..... D12/90

D608,248 S \* 1/2010 Hirai ..... D12/90

D610,039 S \* 2/2010 Koide et al. .... D12/90  
D617,684 S \* 6/2010 Nagura et al. .... D12/92  
D619,047 S \* 7/2010 Foster ..... D12/91

\* cited by examiner

*Primary Examiner*—Melody N Brown

(74) *Attorney, Agent, or Firm*—Westerman, Hattori, Daniels  
& Adrian, LLP

(57) **CLAIM**

What is claimed is; the ornamental design for, an automobile  
and/or replica thereof, as shown and described.

**DESCRIPTION**

FIG. 1 is a first perspective view of an automobile and/or  
replica thereof, showing our new design;

FIG. 2 is a second perspective view thereof;

FIG. 3 is a front elevation view thereof;

FIG. 4 is a rear elevation view thereof;

FIG. 5 is a top plan view thereof; and,

FIG. 6 is a right side elevation view thereof.

The left side elevation view is a mirror image of the right side  
elevation view. The broken lines are for illustrative purposes  
only and form no part of the claimed design.

**1 Claim, 5 Drawing Sheets**

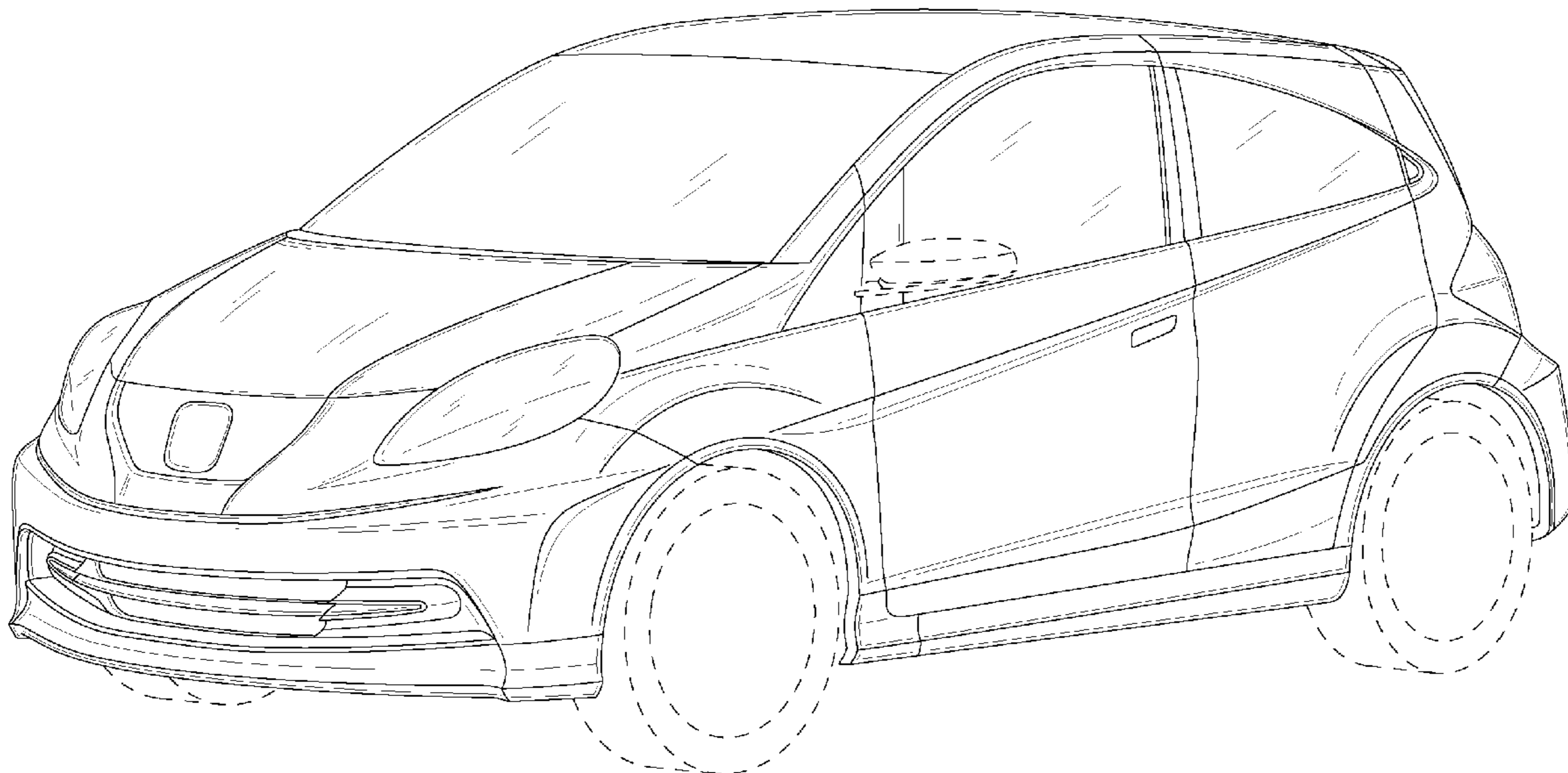

Fig. 1

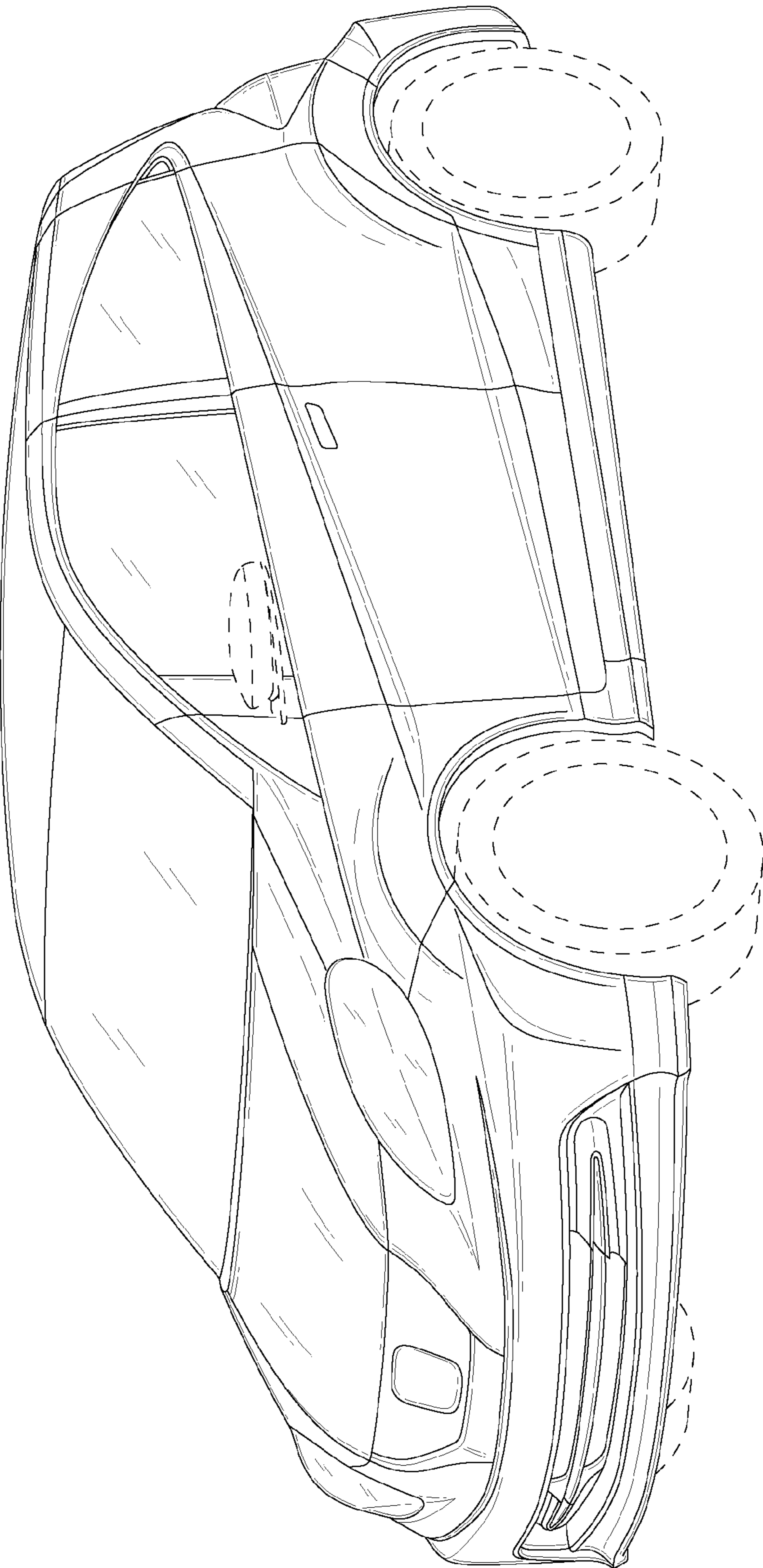

Fig. 2

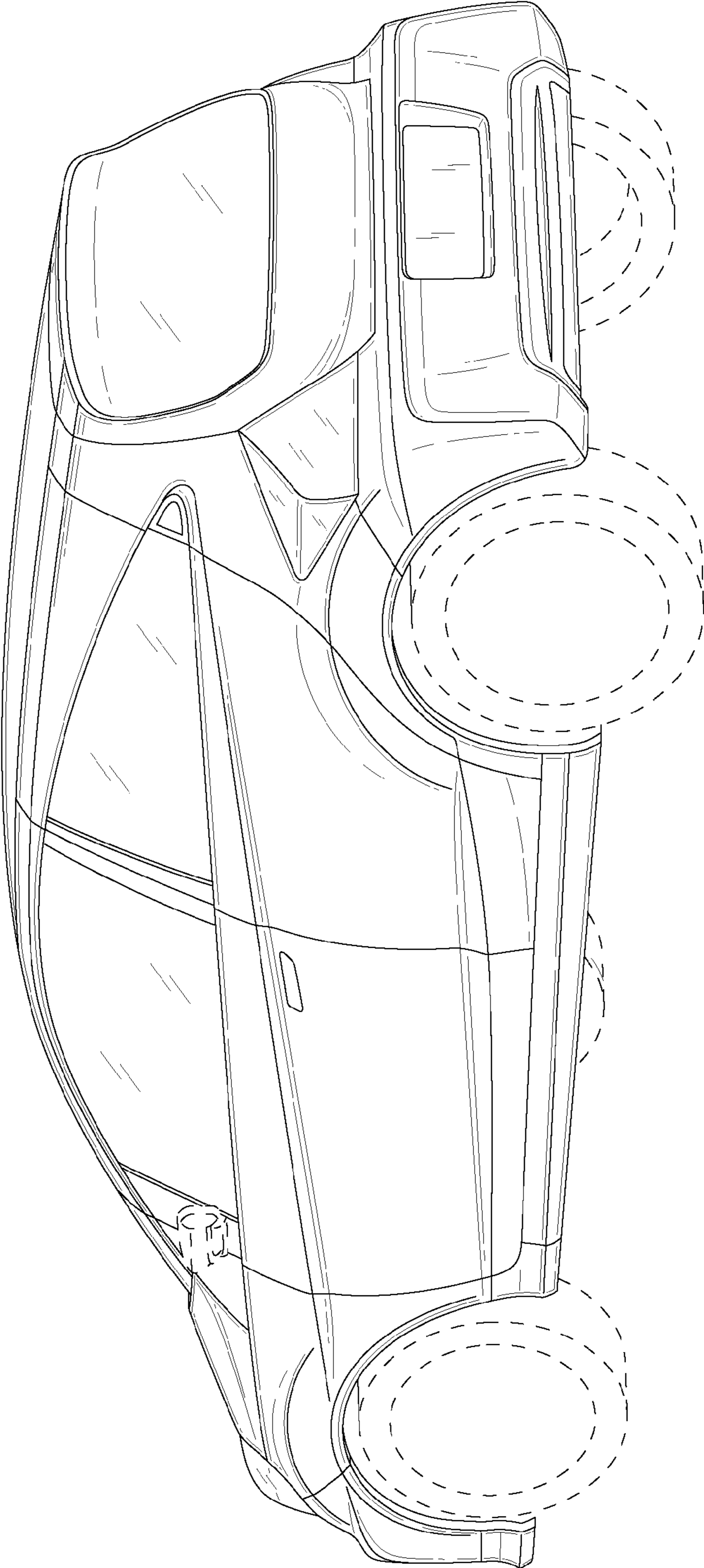

Fig. 4

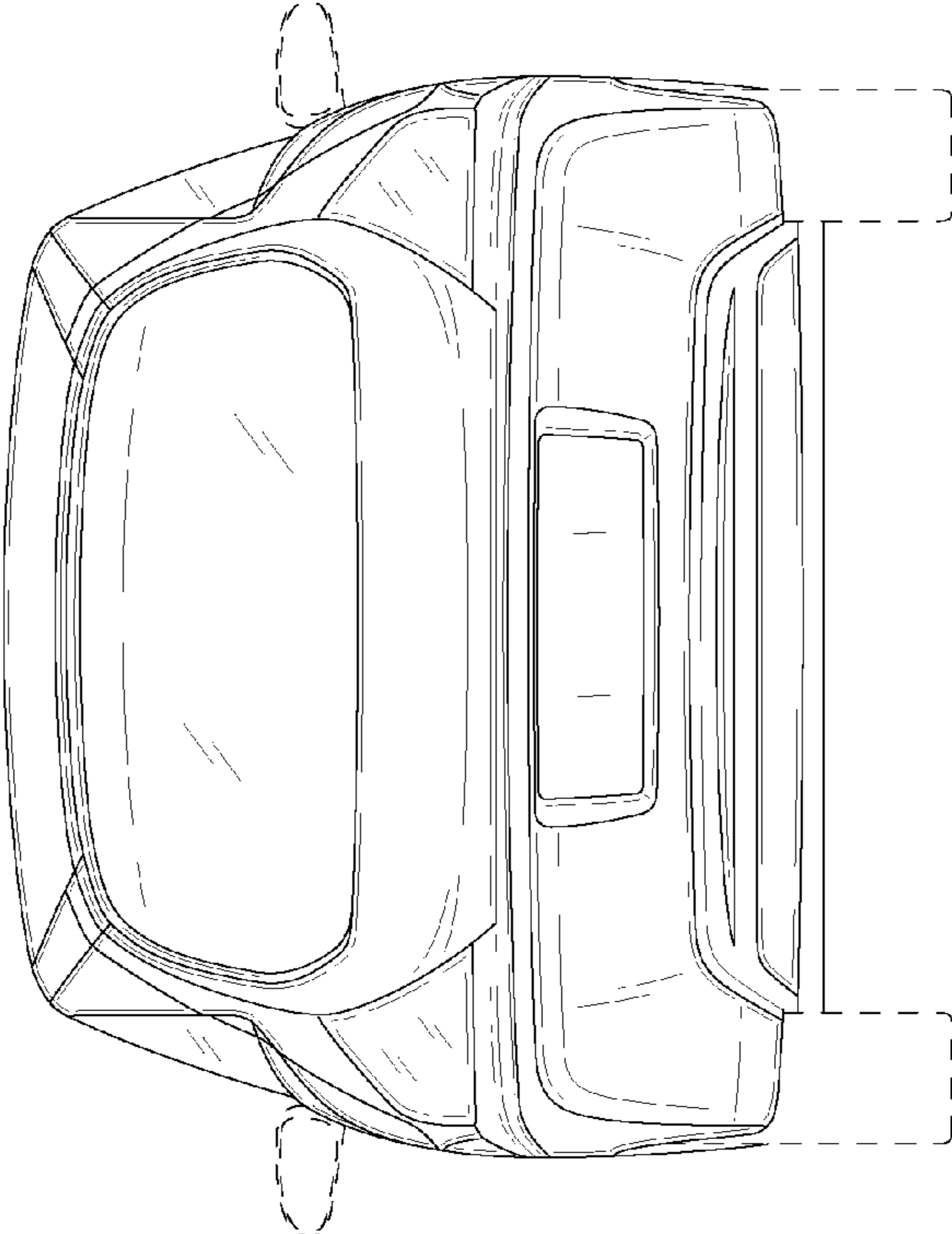
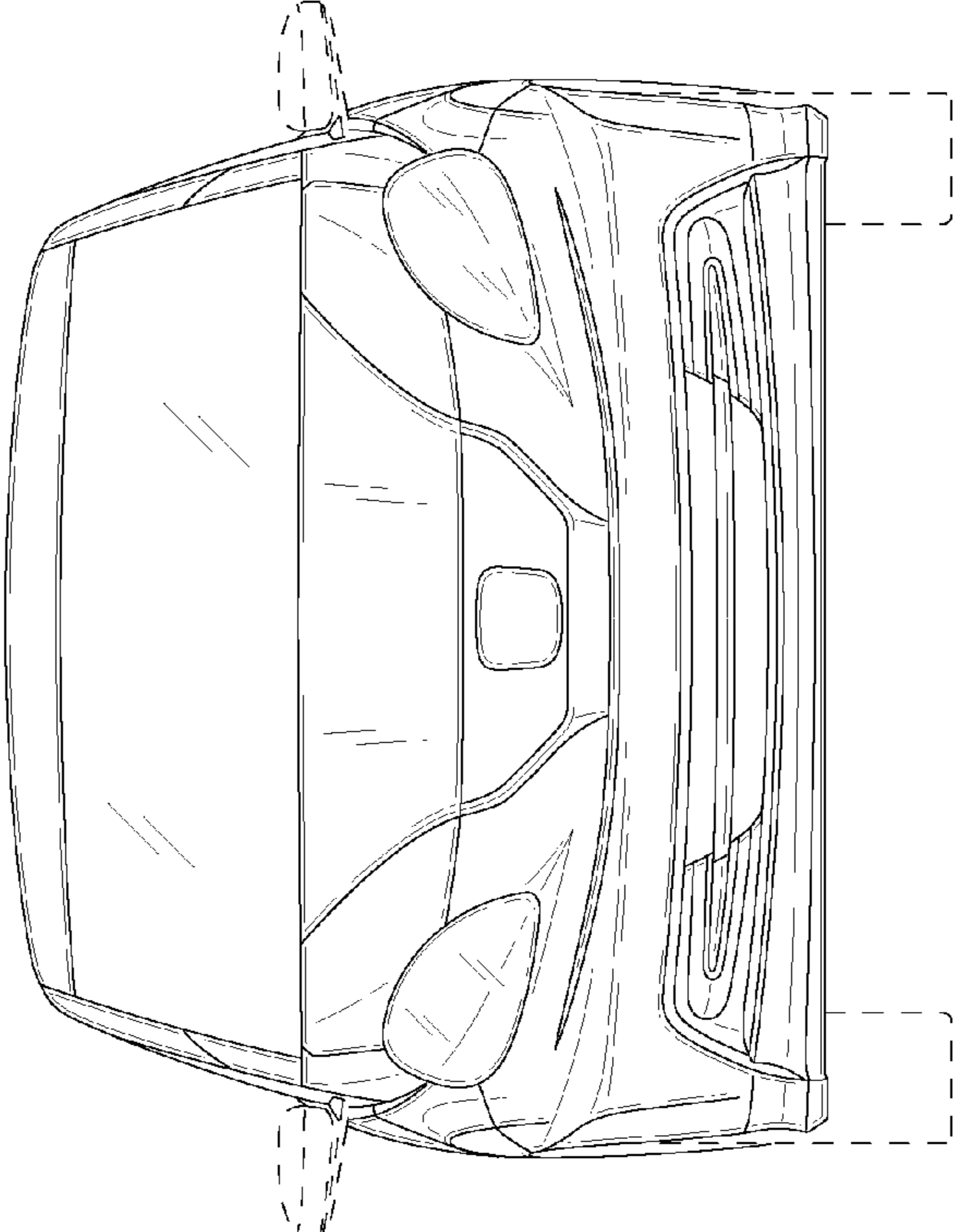

Fig. 3



*Fig. 5*

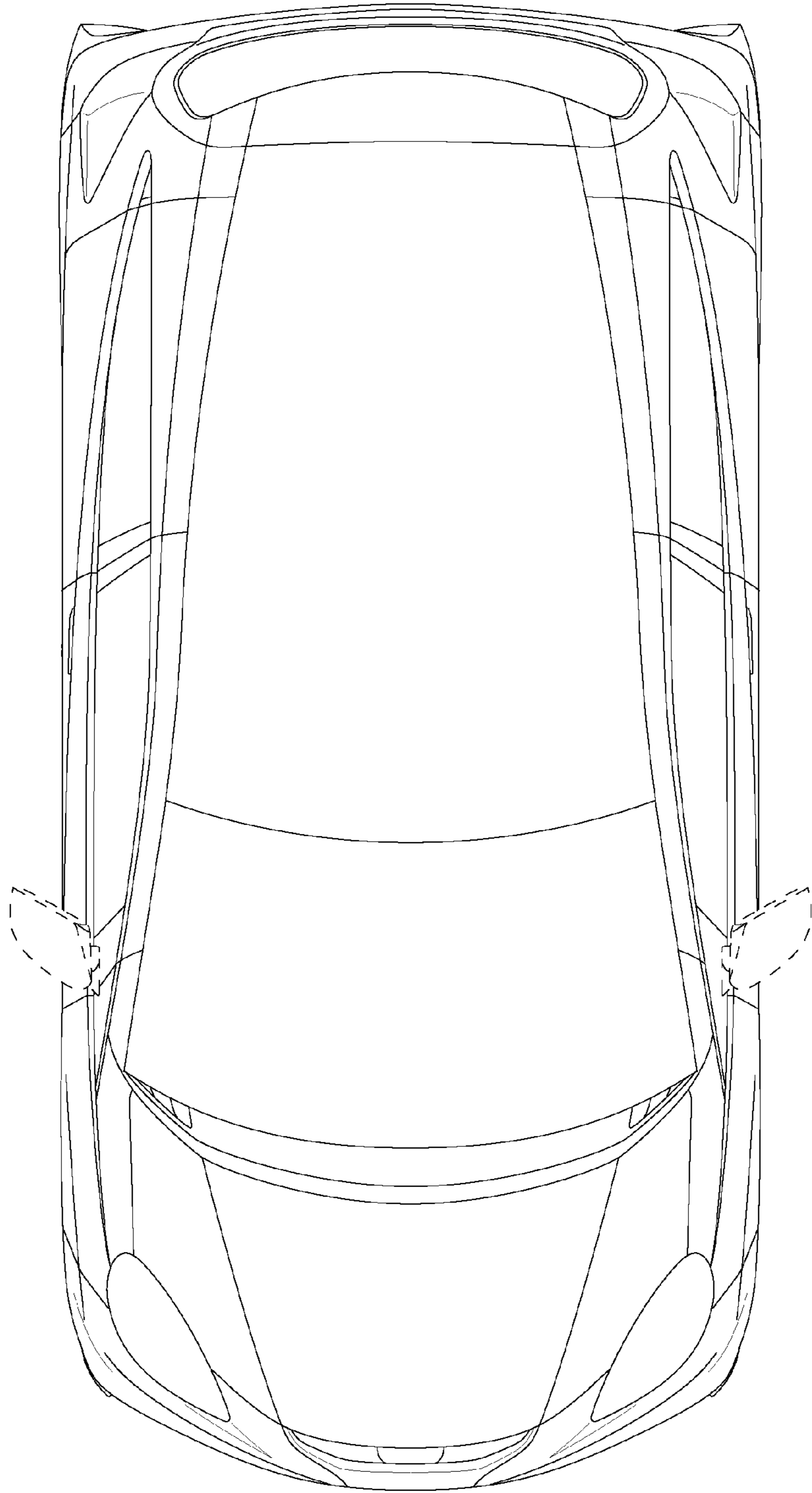

Fig. 6

