



US00D633006S

(12) **United States Design Patent**
Sanschagrín et al.

(10) **Patent No.:** **US D633,006 S**

(45) **Date of Patent:** **** Feb. 22, 2011**

(54) **UTILITY VEHICLE**

2005/0212244 A1* 9/2005 Bobbitt et al. 280/86.751

(75) Inventors: **Stephane Sanschagrín**, Valcourt (CA);
Jean-Philippe Crepeau, Bromont (CA)

* cited by examiner

(73) Assignee: **Bombardier Recreational Products Inc.**, Valcourt (CA)

Primary Examiner—T. Chase Nelson

Assistant Examiner—Ania K Dworzecka

(74) *Attorney, Agent, or Firm*—Osler, Hoskin & Harcourt LLP

(**) Term: **14 Years**

(57) **CLAIM**

(21) Appl. No.: **29/362,947**

The ornamental design for a utility vehicle, as shown and described.

(22) Filed: **Jun. 2, 2010**

(51) **LOC (9) Cl.** **12-13**

(52) **U.S. Cl.** **D12/1**

(58) **Field of Classification Search** D12/87,
D12/86, 1, 433, 15, 16, 107, 82, 88, 89, 90,
D12/91, 92, 93; D15/30; D21/803; 180/233,
180/908; 280/DIG. 5, 183, 184, 185, 186,
280/28, 37.7

See application file for complete search history.

DESCRIPTION

FIG. 1 is a perspective view taken from a front, left side of a utility vehicle according to a first embodiment of our design;

FIG. 2 is a perspective view taken from a rear, left side thereof;

FIG. 3 is a perspective view taken from a front, right side thereof;

FIG. 4 is a perspective view taken from a rear, right side thereof;

FIG. 5 is a front elevation view thereof;

FIG. 6 is a right side elevation view thereof;

FIG. 7 is a left side elevation view thereof;

FIG. 8 is a rear elevation view thereof;

FIG. 9 is a top plan view thereof;

FIG. 10 is a bottom plan view thereof;

FIG. 11 is a perspective view taken from a front, left side of a utility vehicle according to a second embodiment of our design;

FIG. 12 is a perspective view taken from a rear, left side thereof;

FIG. 13 is a perspective view taken from a front, right side thereof;

FIG. 14 is a perspective view taken from a rear, right side thereof;

FIG. 15 is a front elevation view thereof;

FIG. 16 is a right side elevation view thereof;

(56) **References Cited**

U.S. PATENT DOCUMENTS

D332,239 S	1/1993	Hirata et al.	
D439,548 S	3/2001	Kouchi et al.	
D498,435 S	11/2004	Saito et al.	
D503,905 S	4/2005	Saito et al.	
D504,638 S	5/2005	Tanaka et al.	
D511,317 S	11/2005	Tanaka et al.	
D555,036 S *	11/2007	Eck	D12/87
7,367,247 B2 *	5/2008	Horiuchi et al.	74/606 R
D578,433 S *	10/2008	Kawaguchi et al.	D12/14
D578,934 S *	10/2008	Tanaka et al.	D12/14
D592,998 S *	5/2009	Woodard et al.	D12/14
D595,613 S *	7/2009	Lai et al.	D12/14
D604,201 S *	11/2009	Kawaguchi et al.	D12/14
D605,555 S	12/2009	Tanaka et al.	
D606,900 S *	12/2009	Flores	D12/87
D607,377 S *	1/2010	Shimomura et al.	D12/14
D610,514 S	2/2010	Eck	
D621,426 S	8/2010	Fusejima et al.	
D622,631 S *	8/2010	Lai et al.	D12/87
D622,645 S	8/2010	Ichihara et al.	

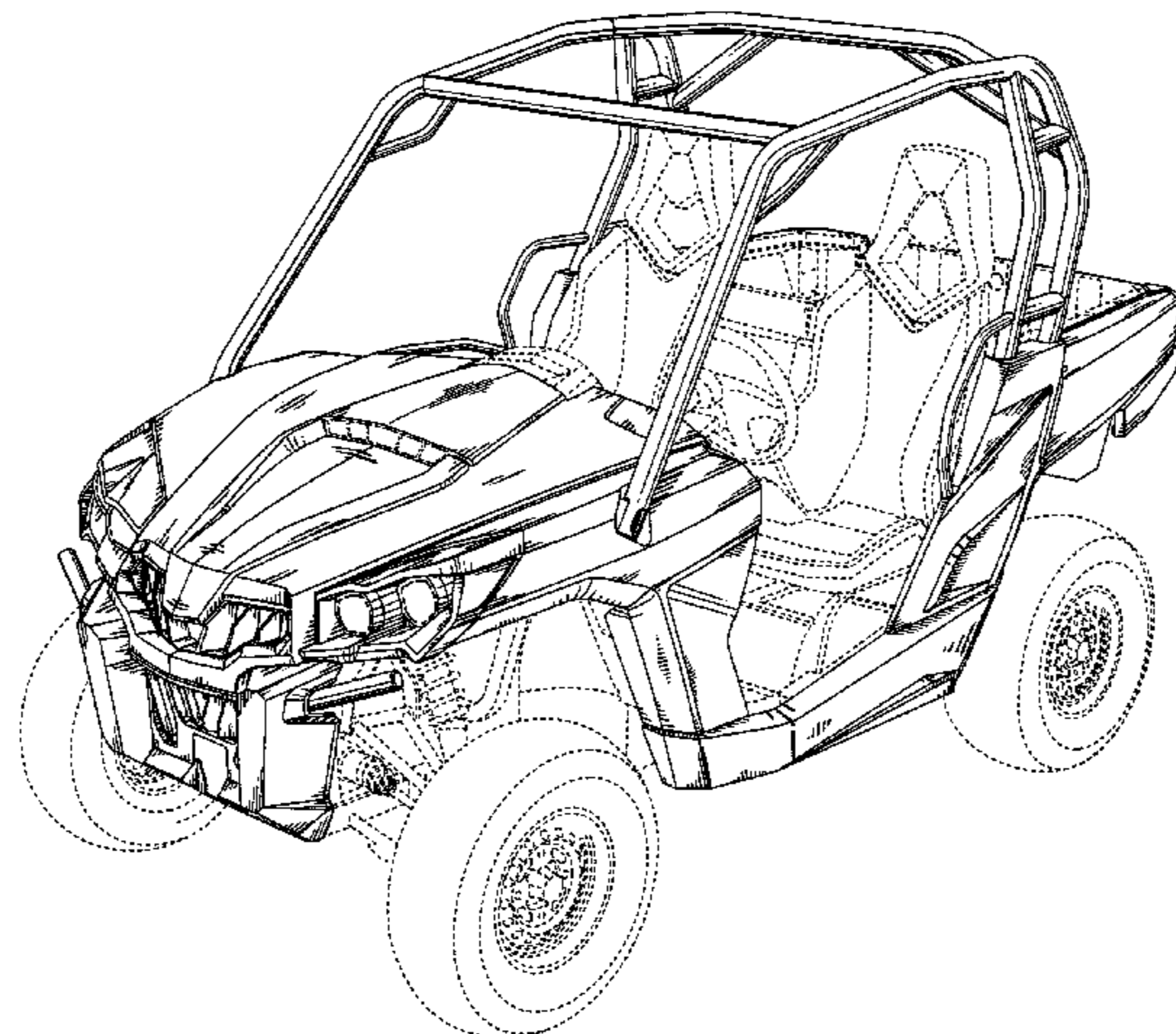

FIG. 17 is a left side elevation view thereof;

FIG. 18 is a rear elevation view thereof;

FIG. 19 is a top plan view thereof;

FIG. 20 is a bottom plan view thereof;

FIG. 21 is a perspective view taken from a front, left side of a utility vehicle according to an alternate broken line environment;

FIG. 22 is a perspective view taken from a rear, left side thereof;

FIG. 23 is a perspective view taken from a front, right side thereof;

FIG. 24 is a perspective view taken from a rear, right side thereof;

FIG. 25 is a front elevation view thereof;

FIG. 26 is a right side elevation view thereof;

FIG. 27 is a left side elevation view thereof;

FIG. 28 is a rear elevation view thereof;

FIG. 29 is a top plan view thereof; and,

FIG. 30 is a bottom plan view thereof.

Throughout the Figures, where shown: (i) the elements of the utility vehicle shown in dotted lines are for illustrative purposes only and do not form part of the claimed design; and, (ii) in FIGS. 11, 12, 13, 14, 15, 18, 19, 20, 21, 22, 23, 24, 25, 28, 29 and 30, the dotted/dashed lines immediately adjacent solid lines represent unclaimed boundaries of the claimed design and as such, the configuration of the unshaded surfaces defined by those dotted/dashed lines form no part of the claimed design. Portions of the utility vehicle not shown in the Figures and not otherwise described in this Specification do not form part of the claimed design. Throughout the Figures, the unshaded surfaces do not form part of the claimed design.

1 Claim, 30 Drawing Sheets

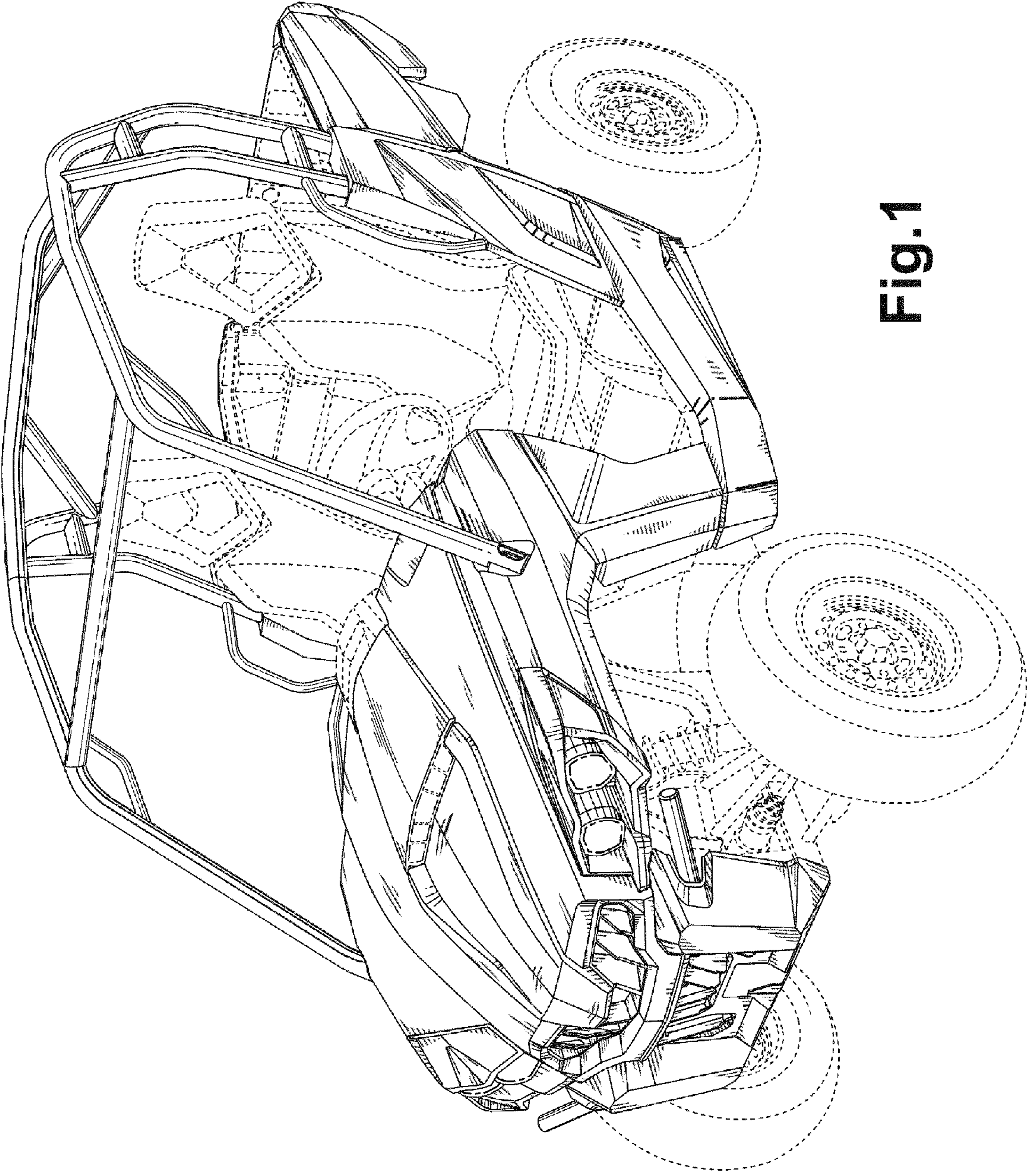

Fig.1

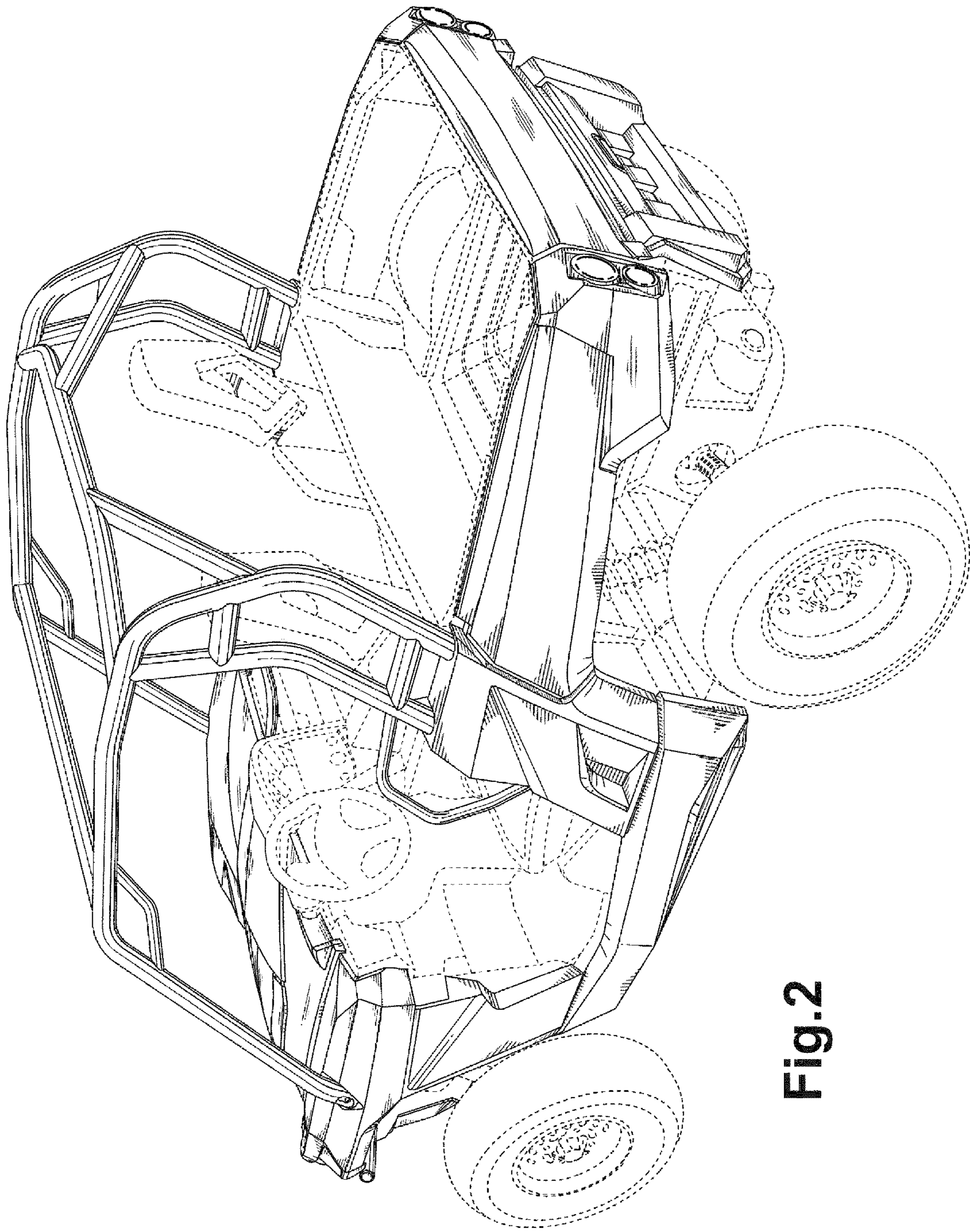

Fig.2

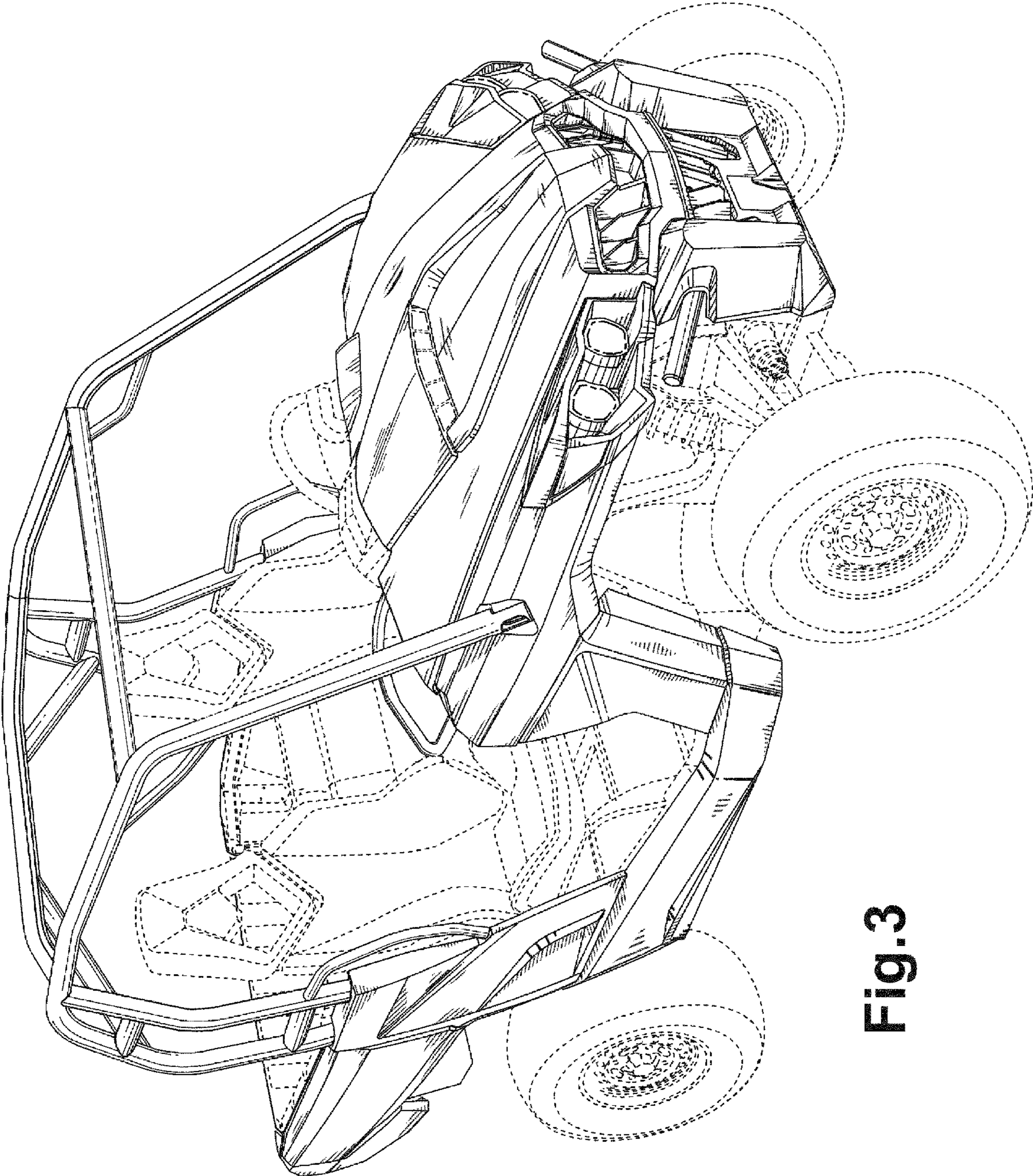

Fig. 3

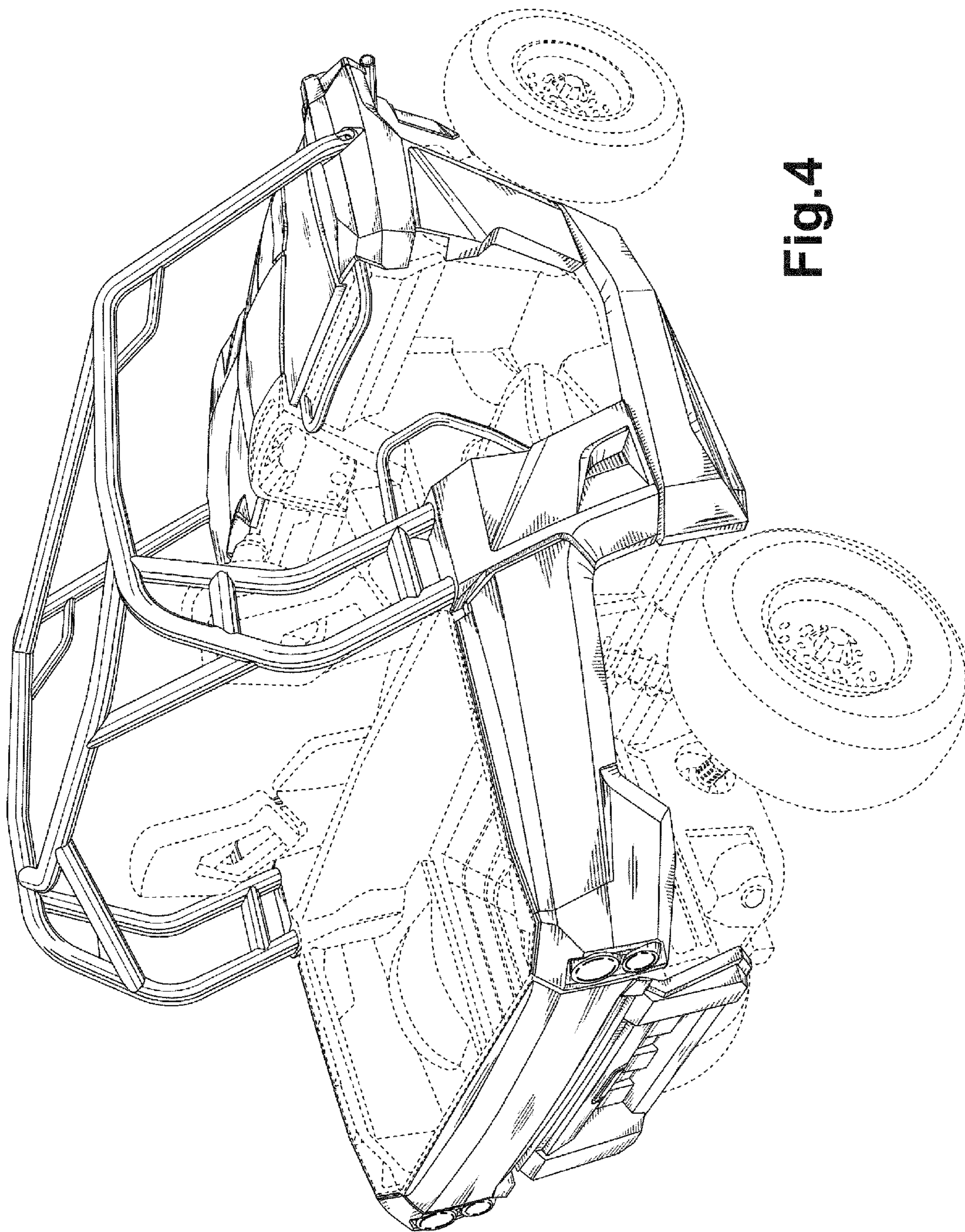

Fig.4

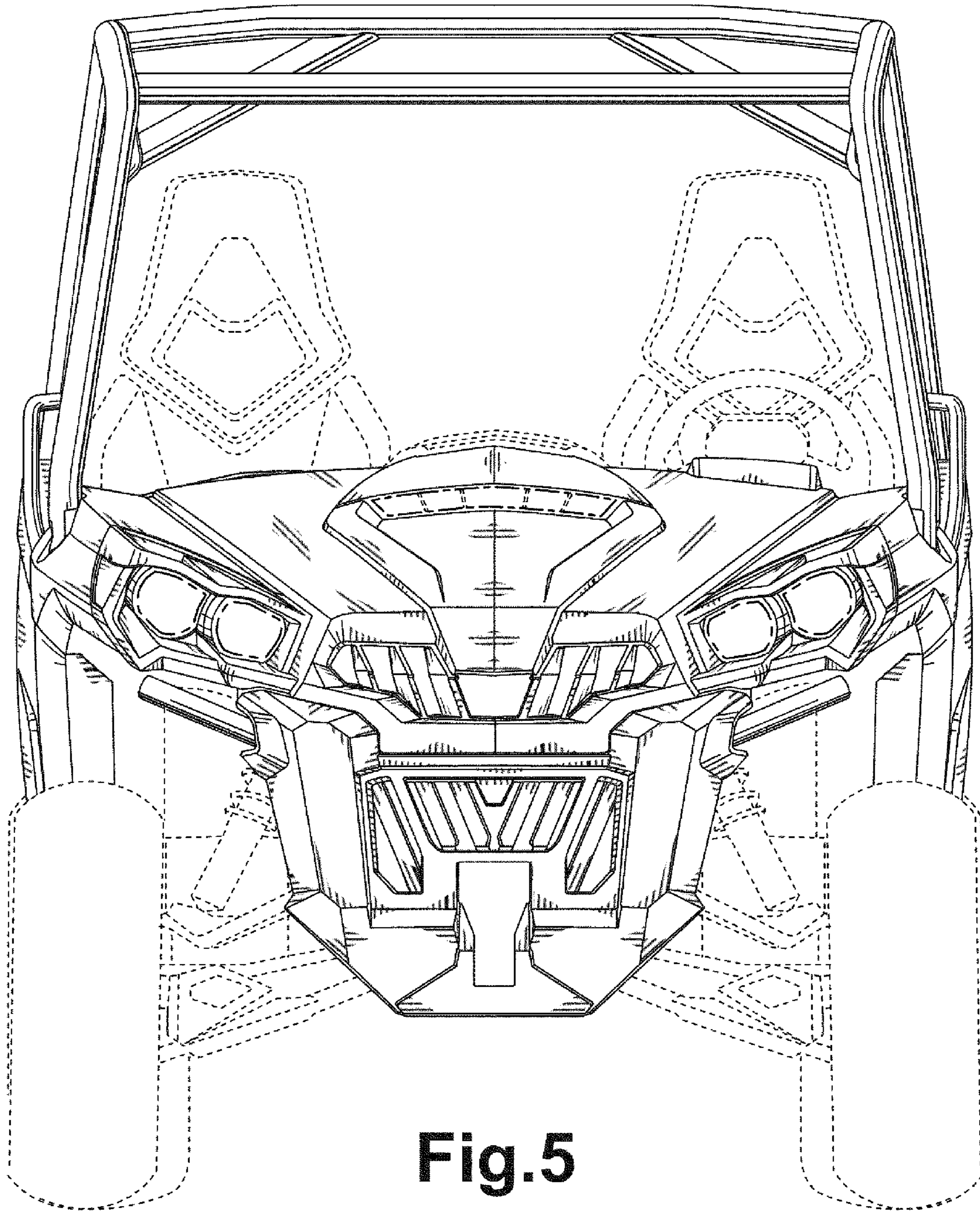

Fig.5

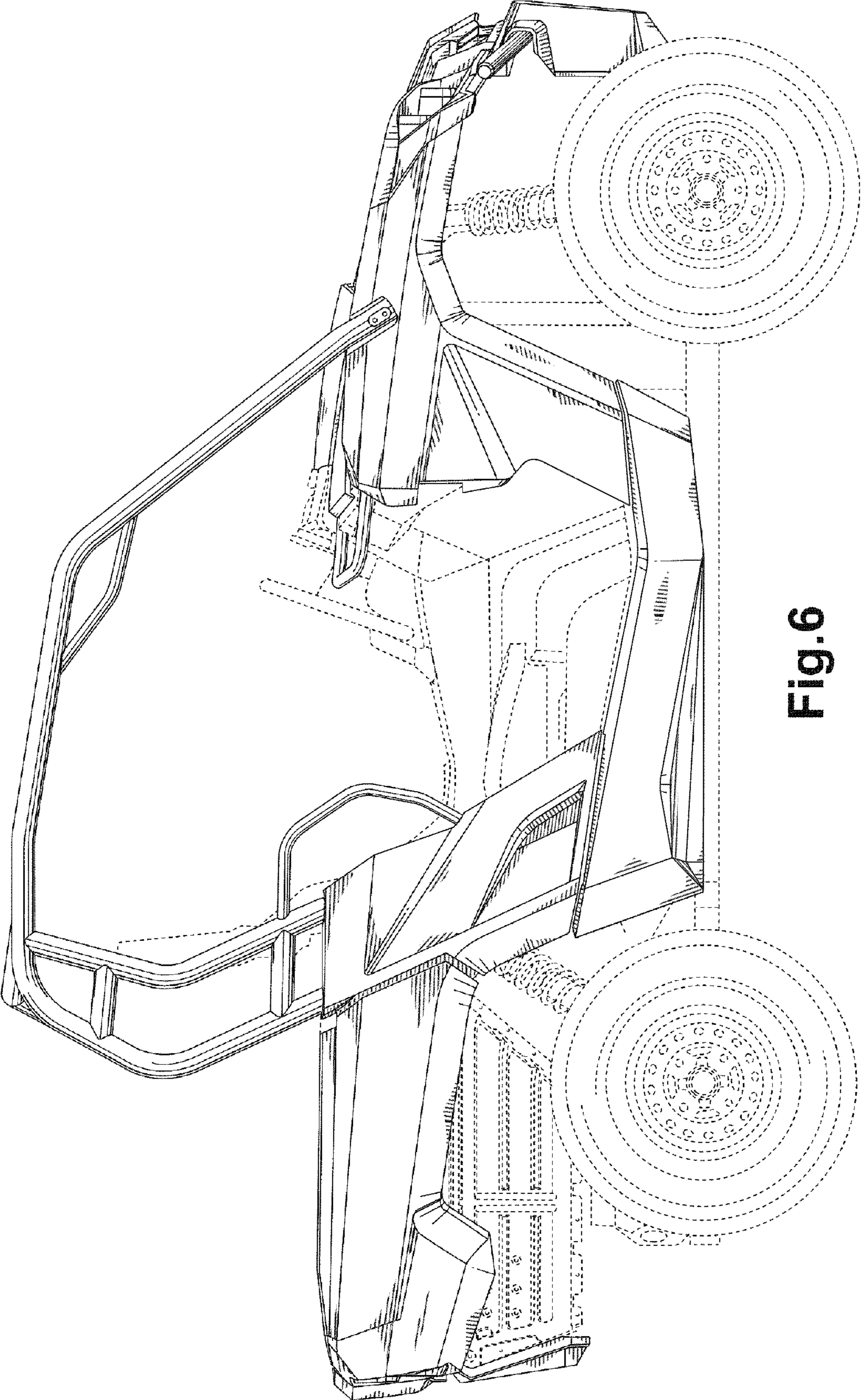

Fig. 6

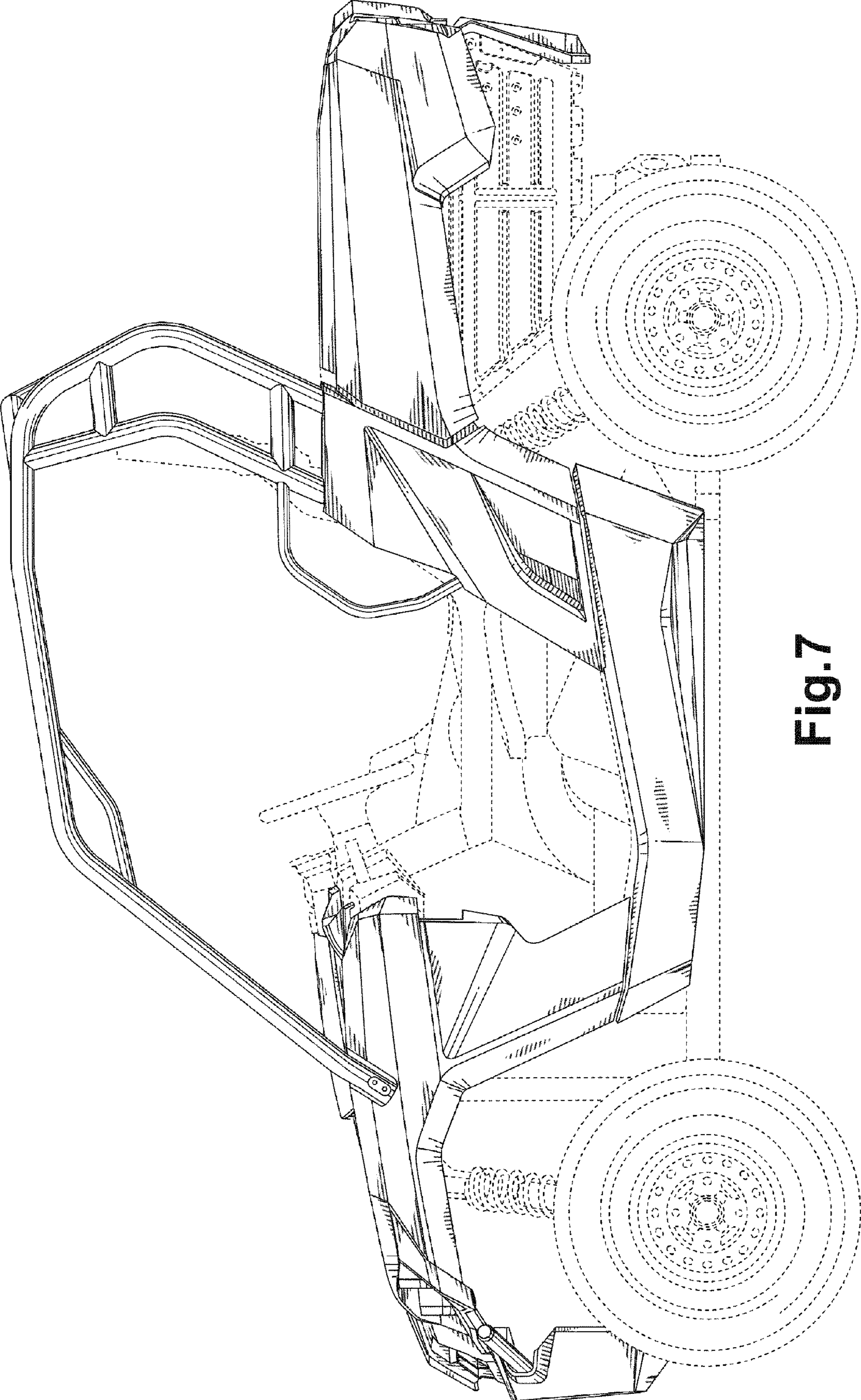

Fig. 7

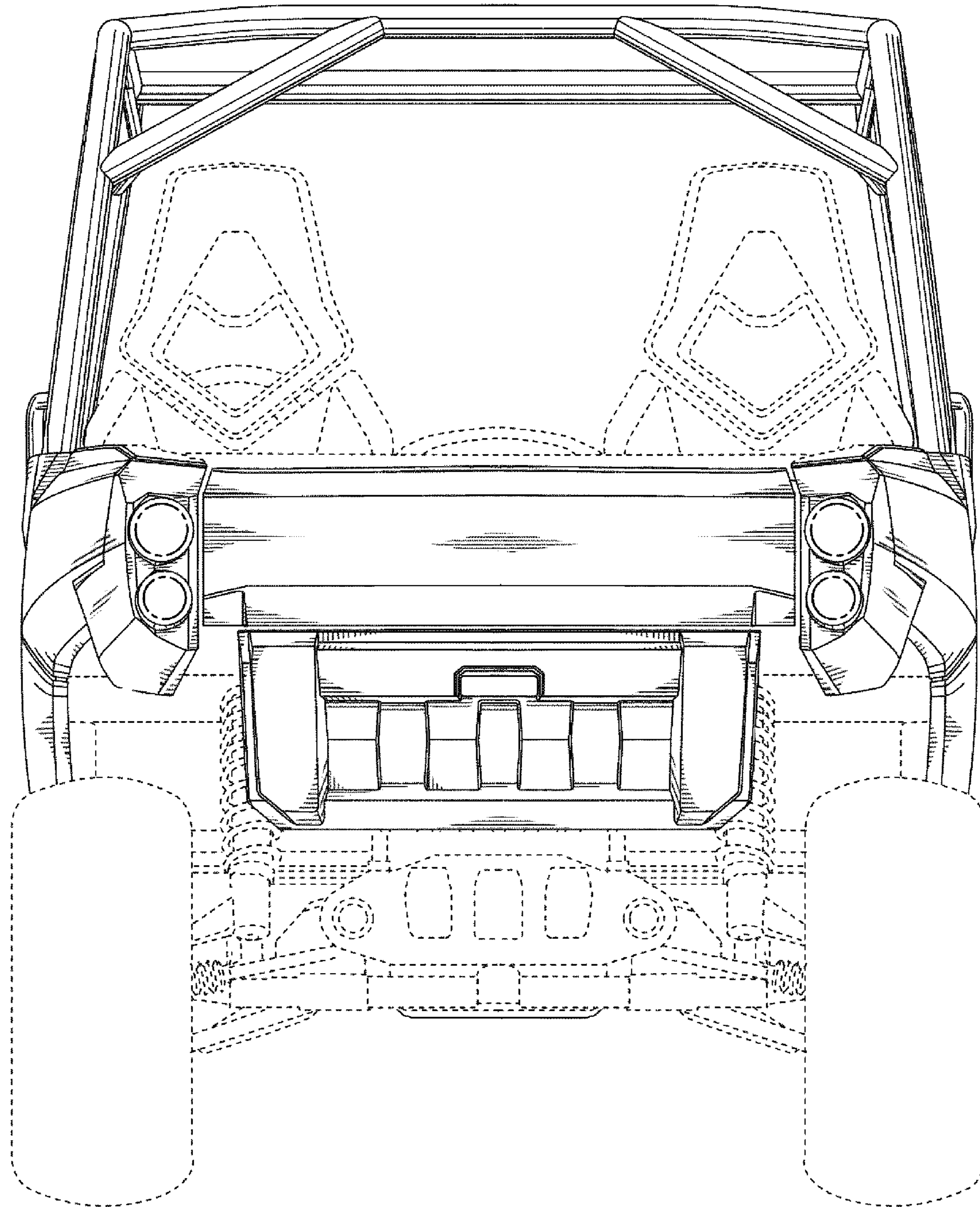

Fig.8

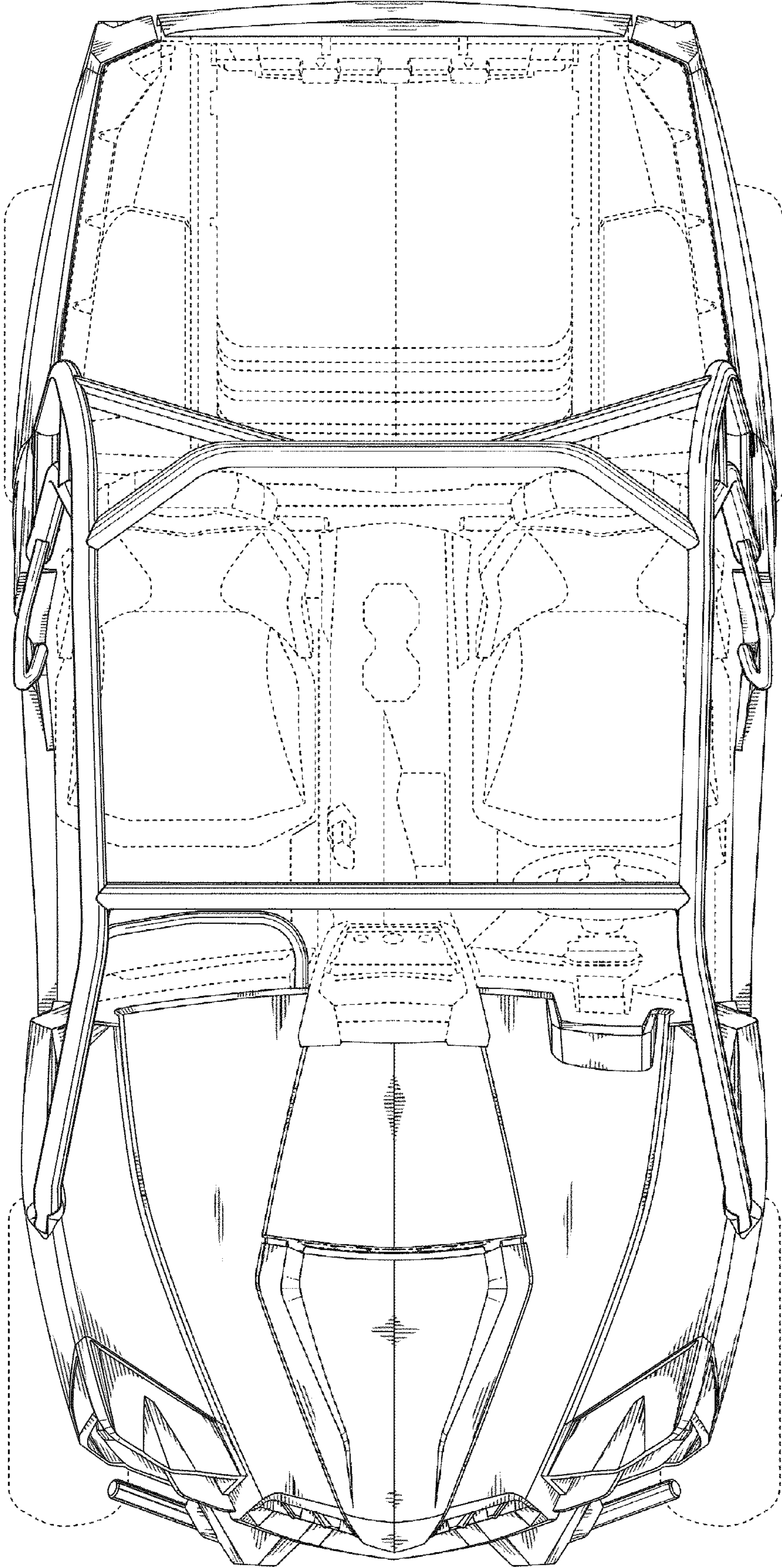

Fig.9

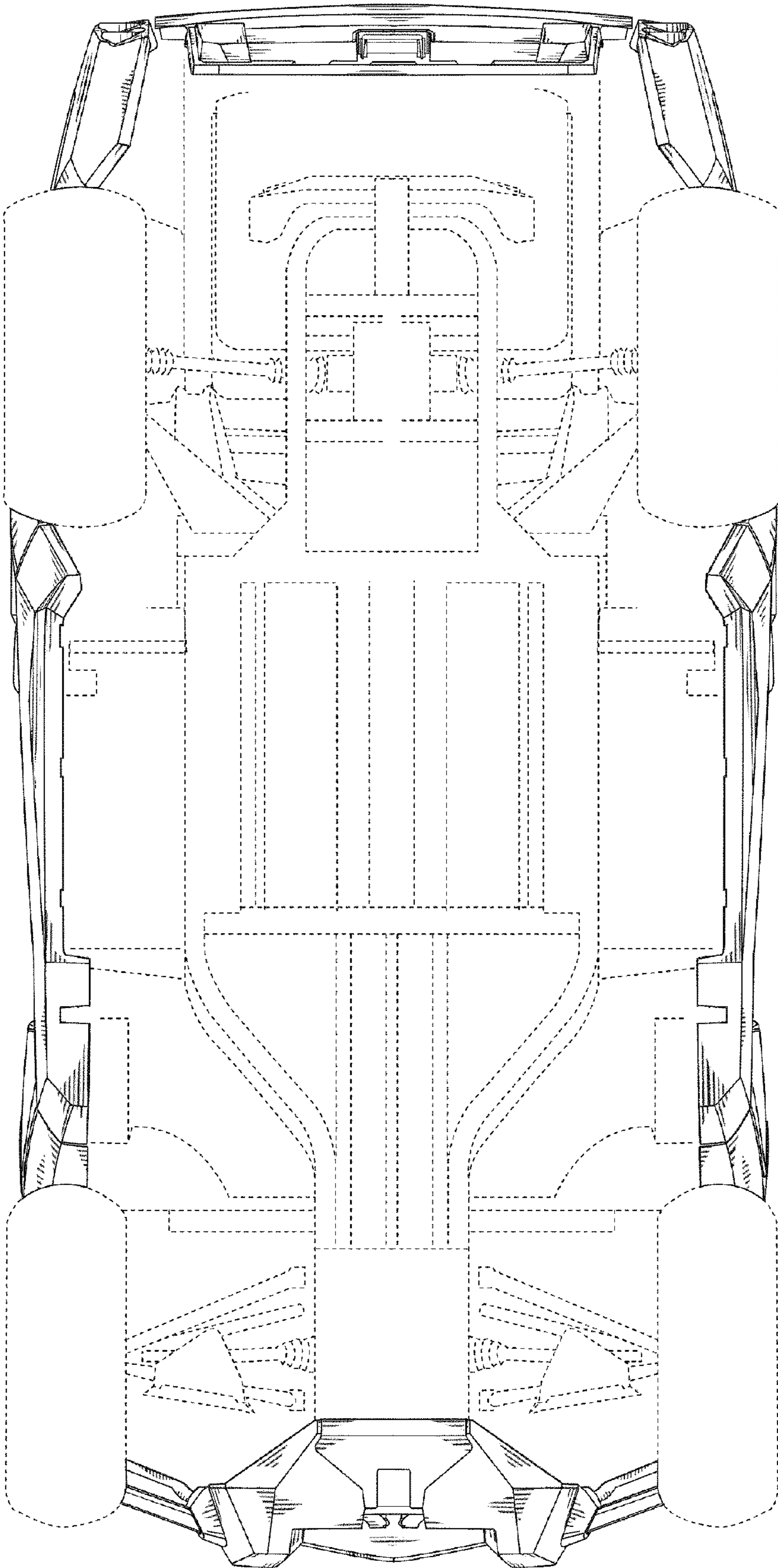

Fig.10

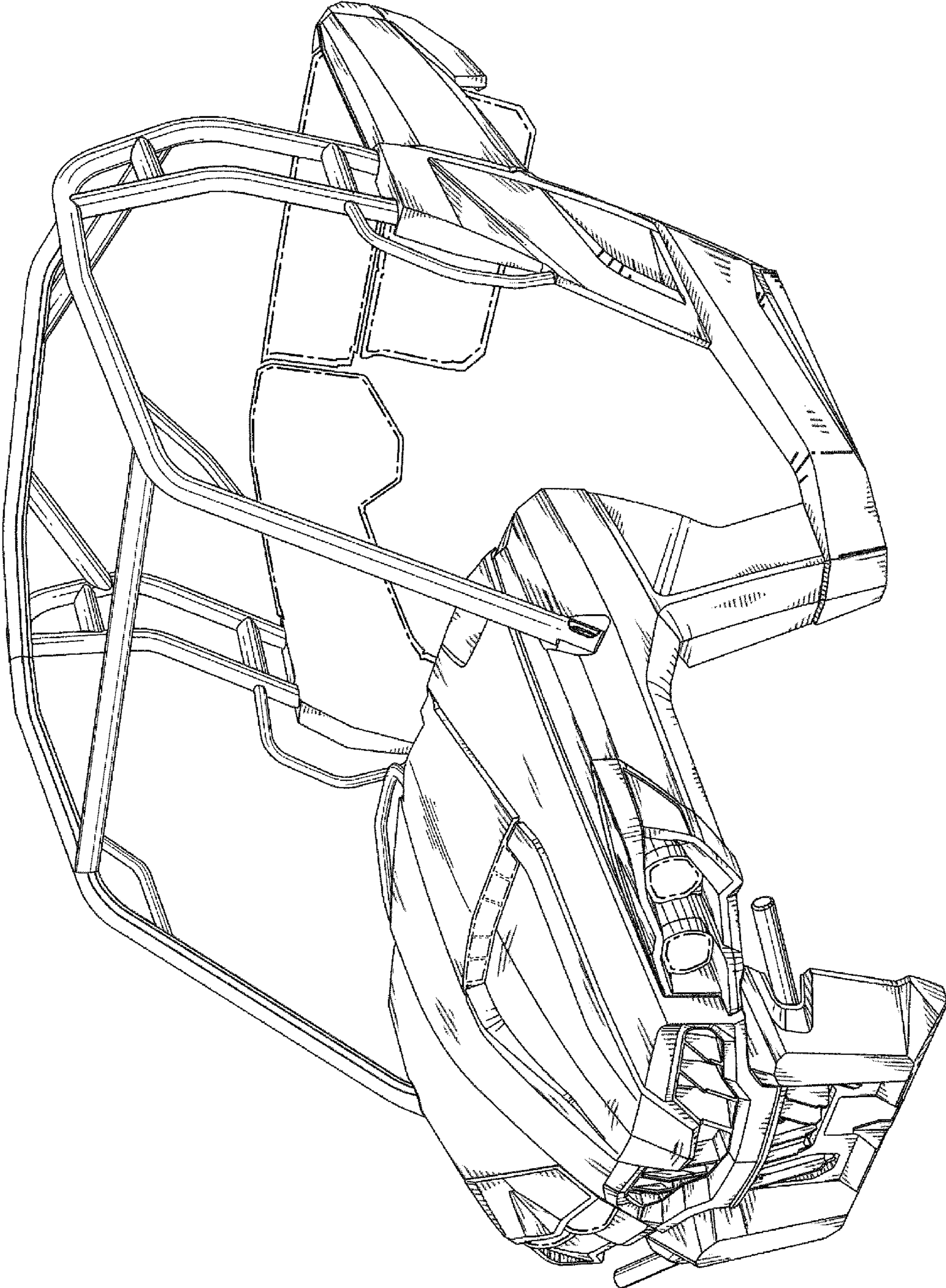

Fig.11

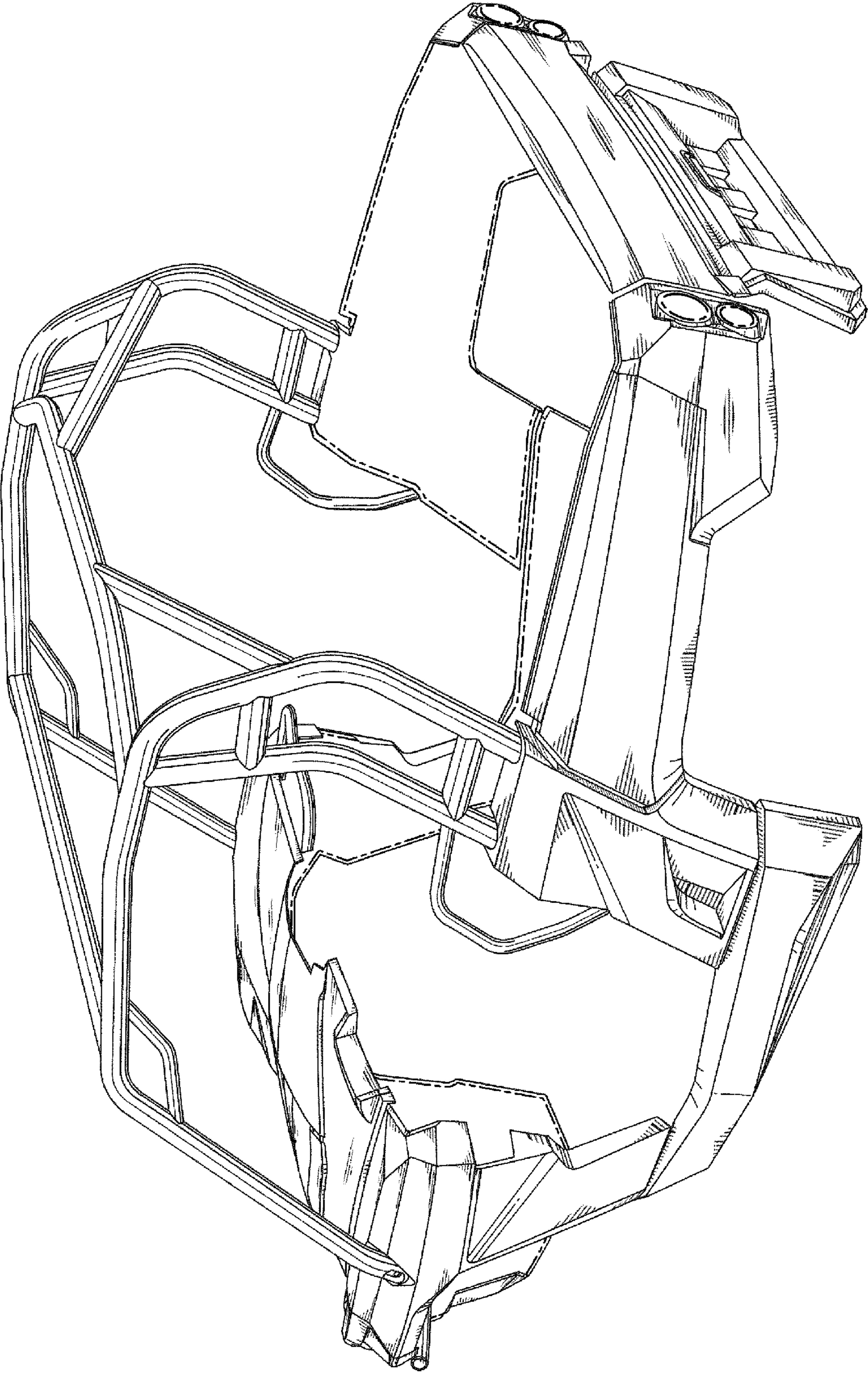

Fig.12

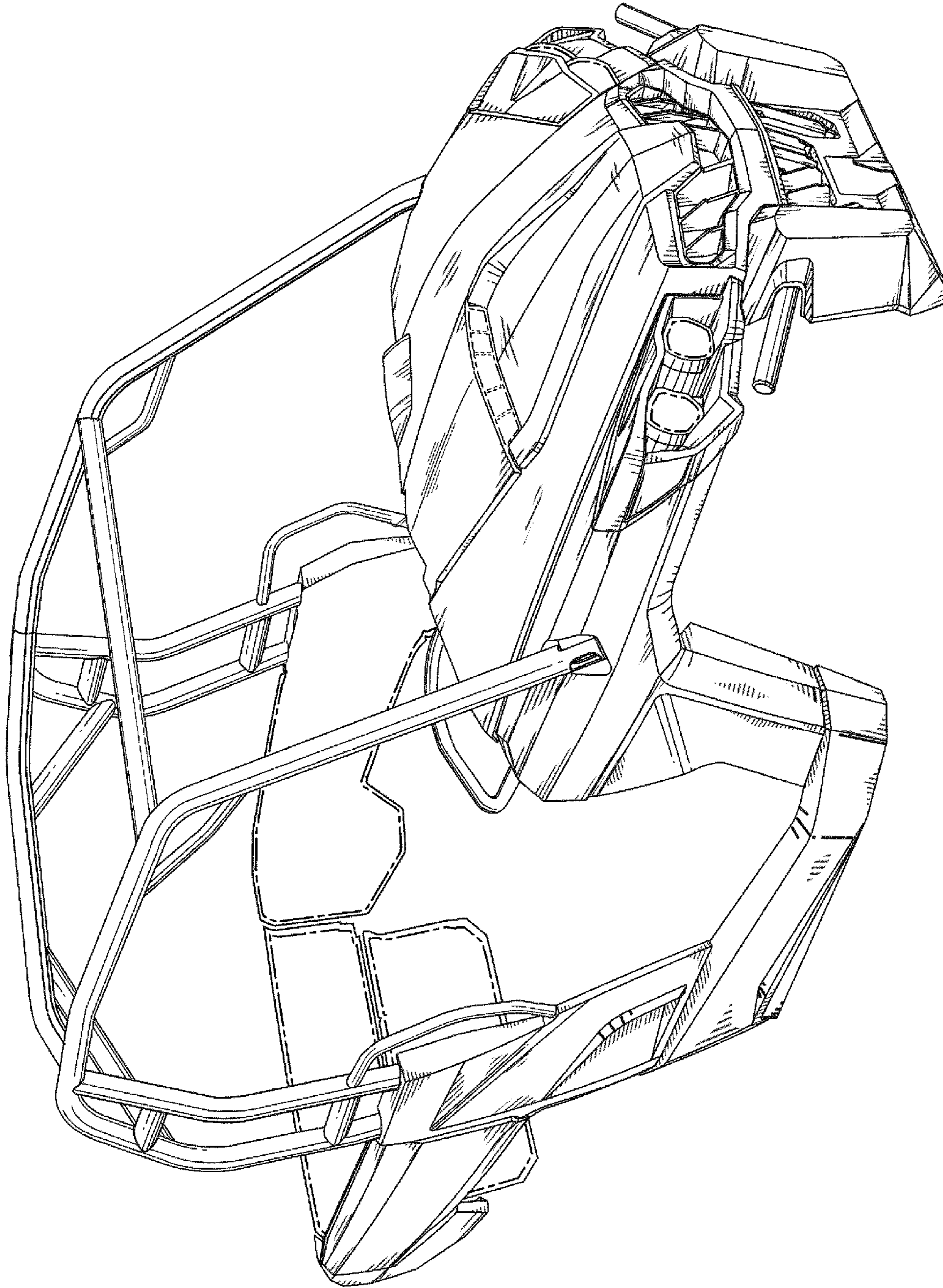

Fig.13

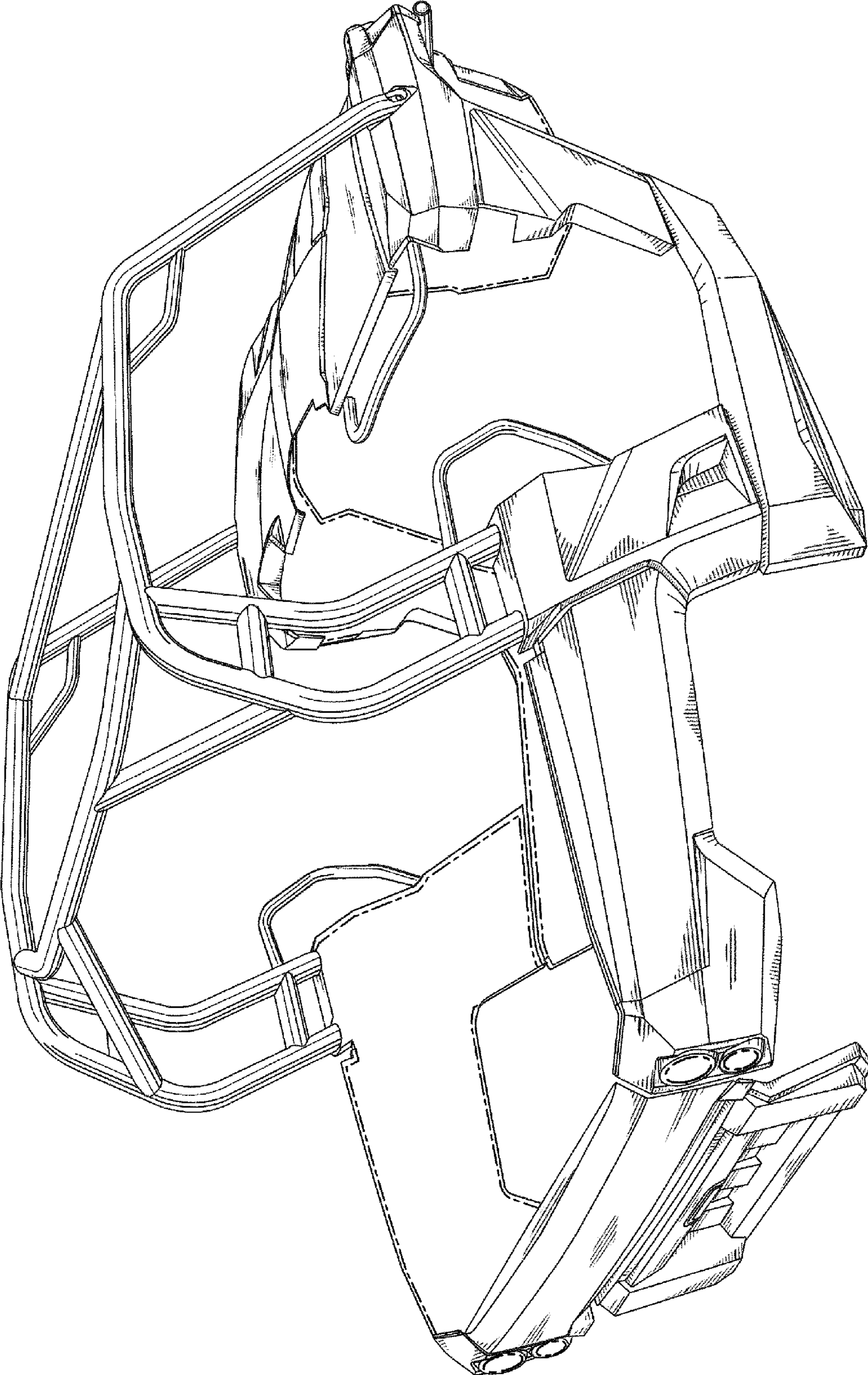

Fig.14

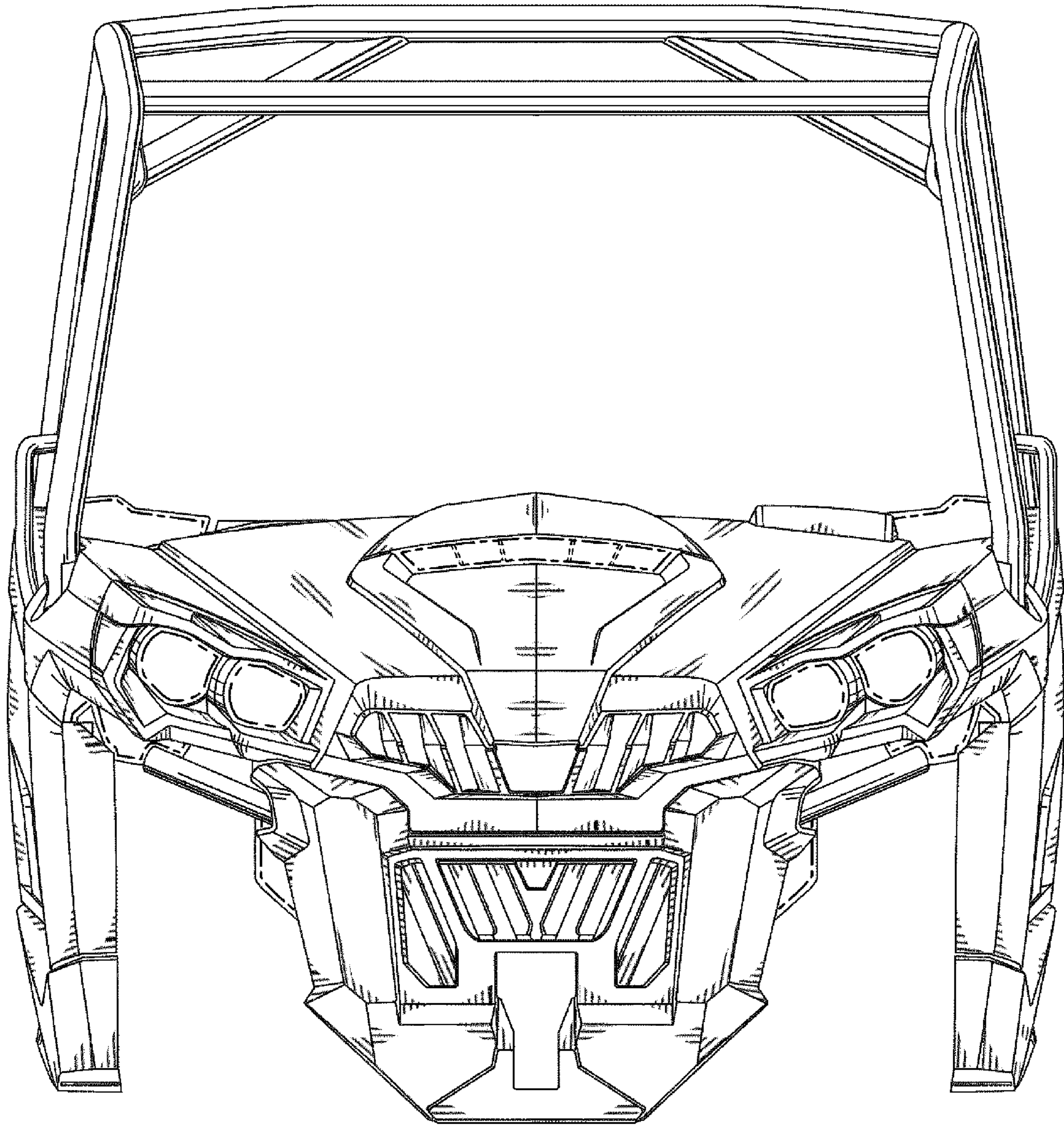

Fig.15

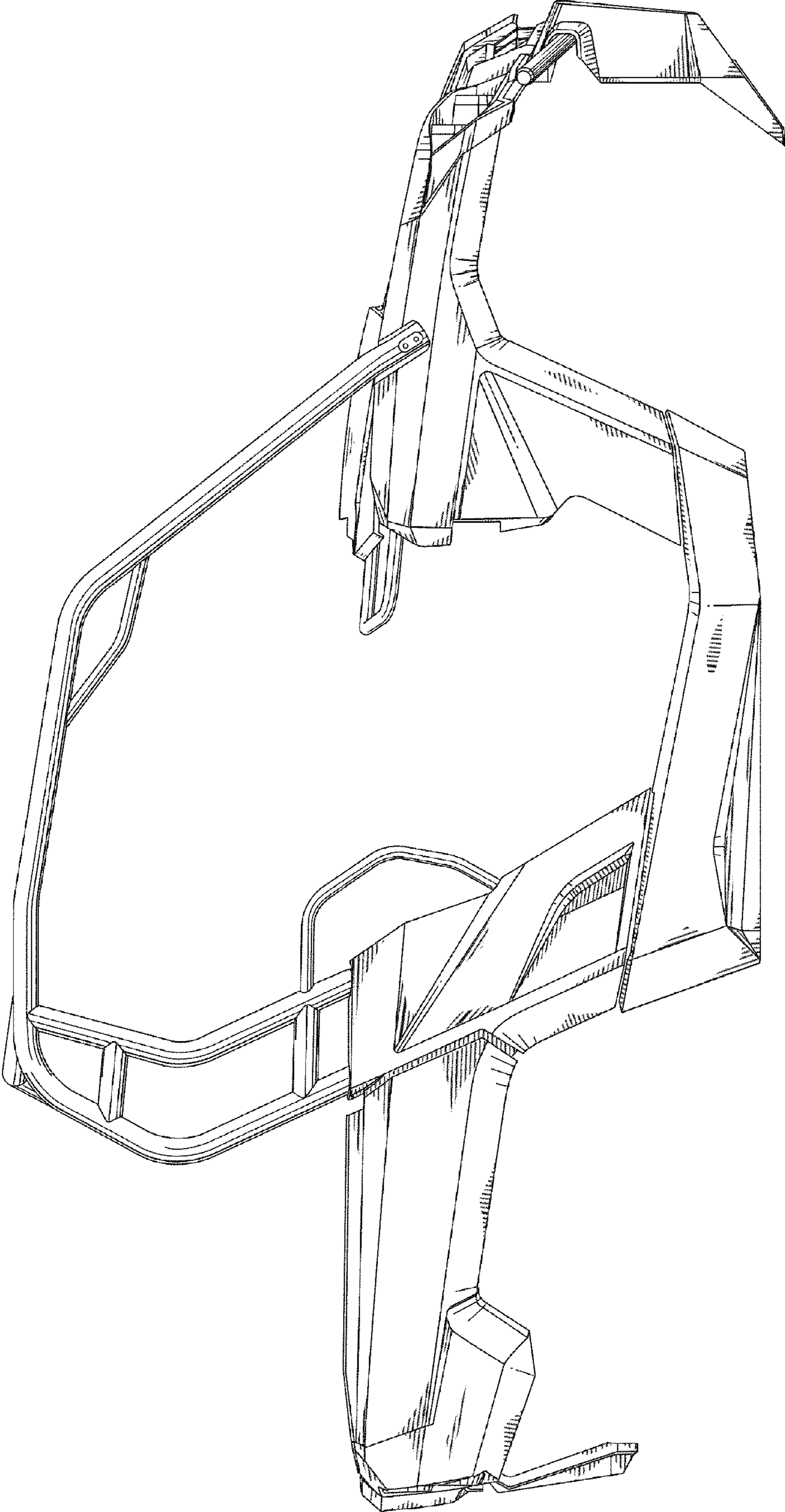

Fig.16

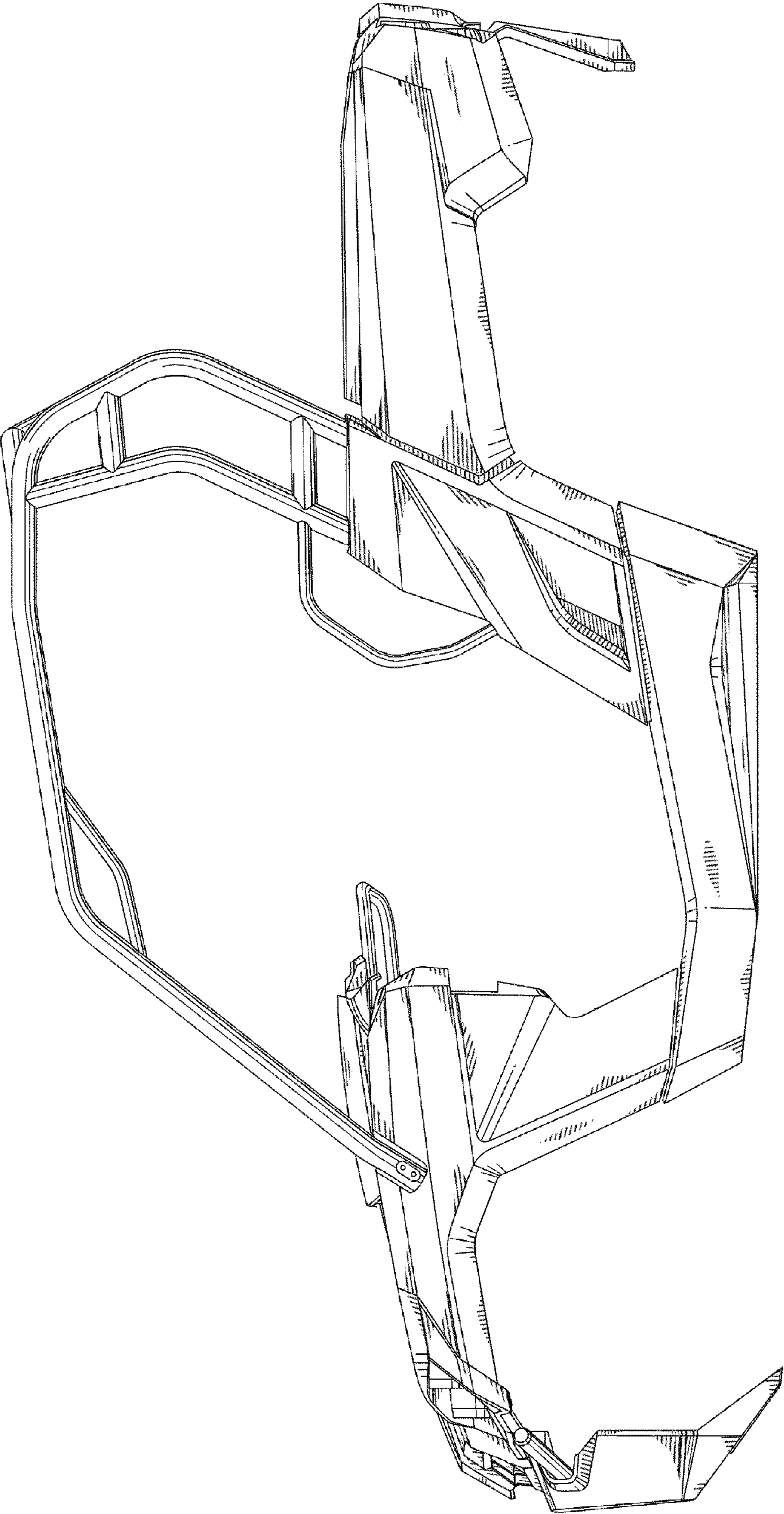

Fig.17

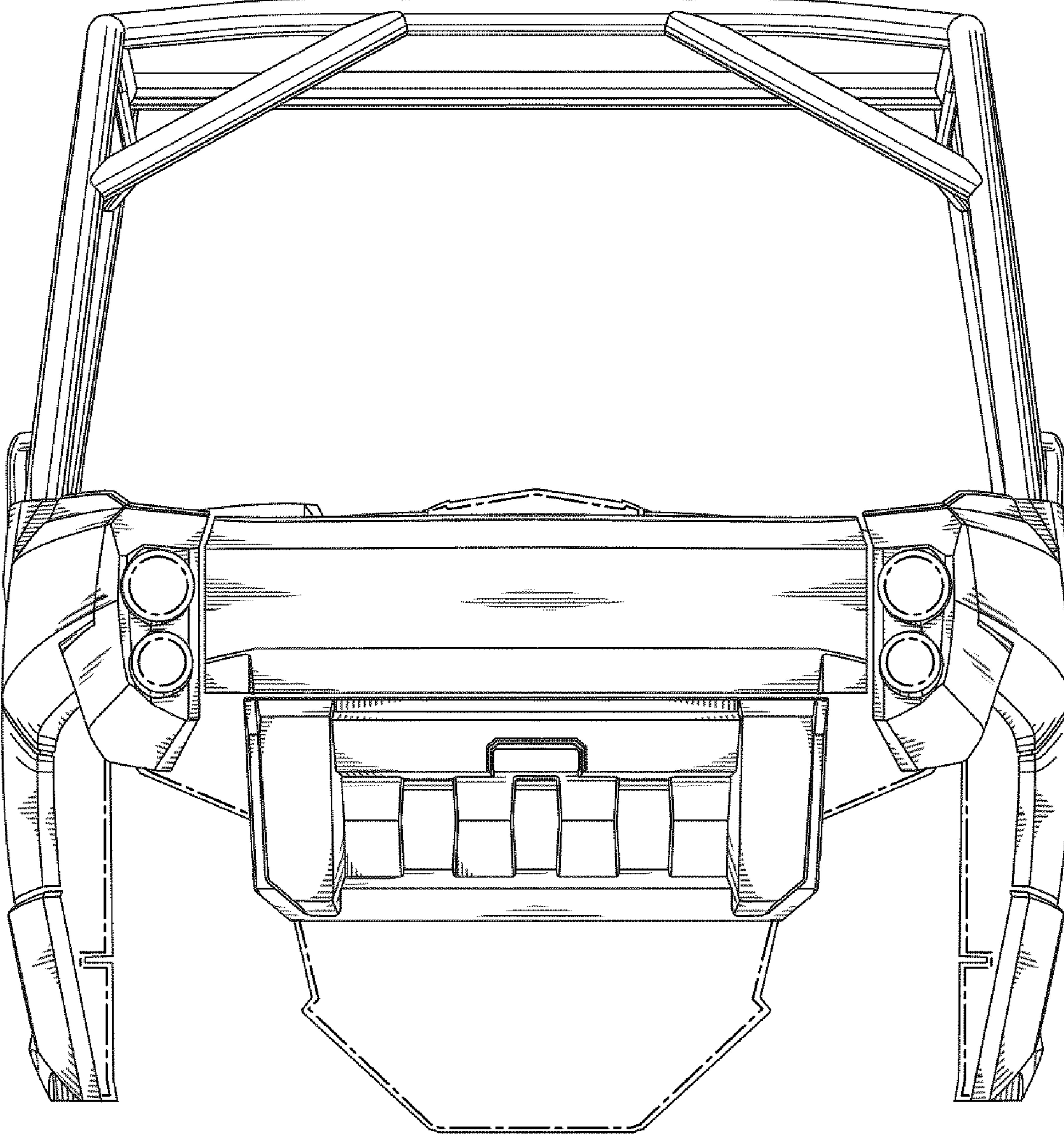

Fig.18

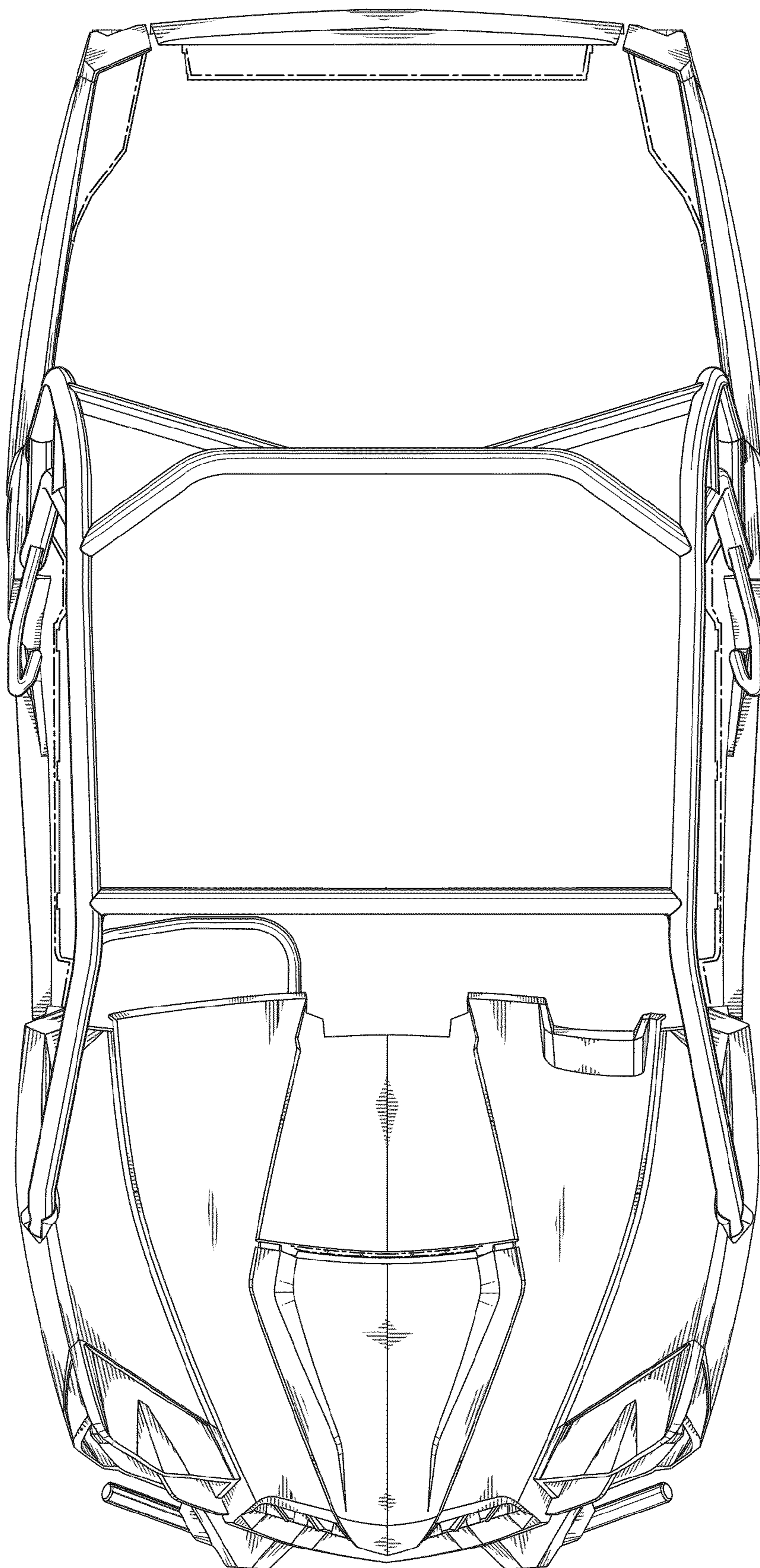

Fig.19

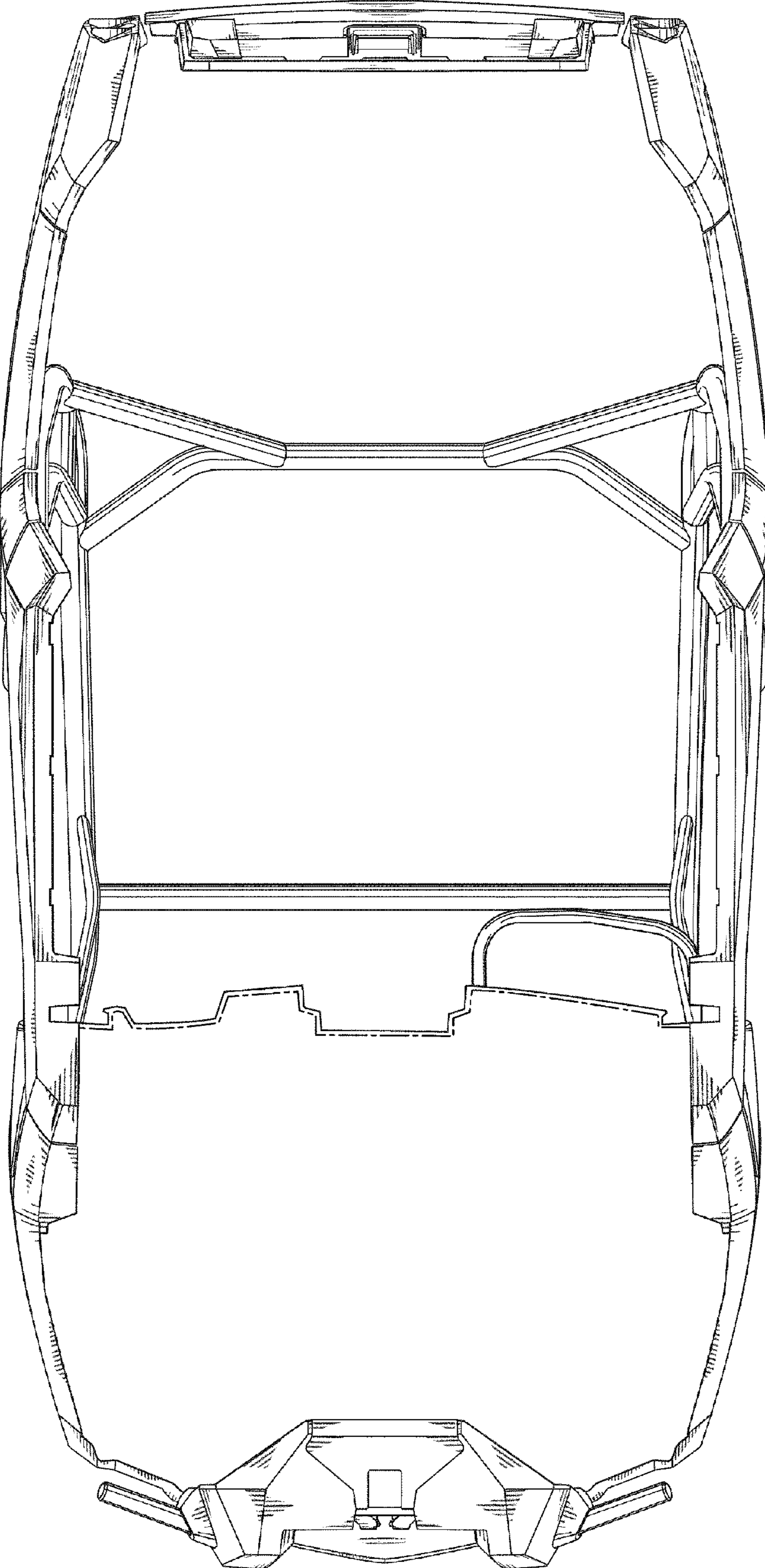

Fig.20

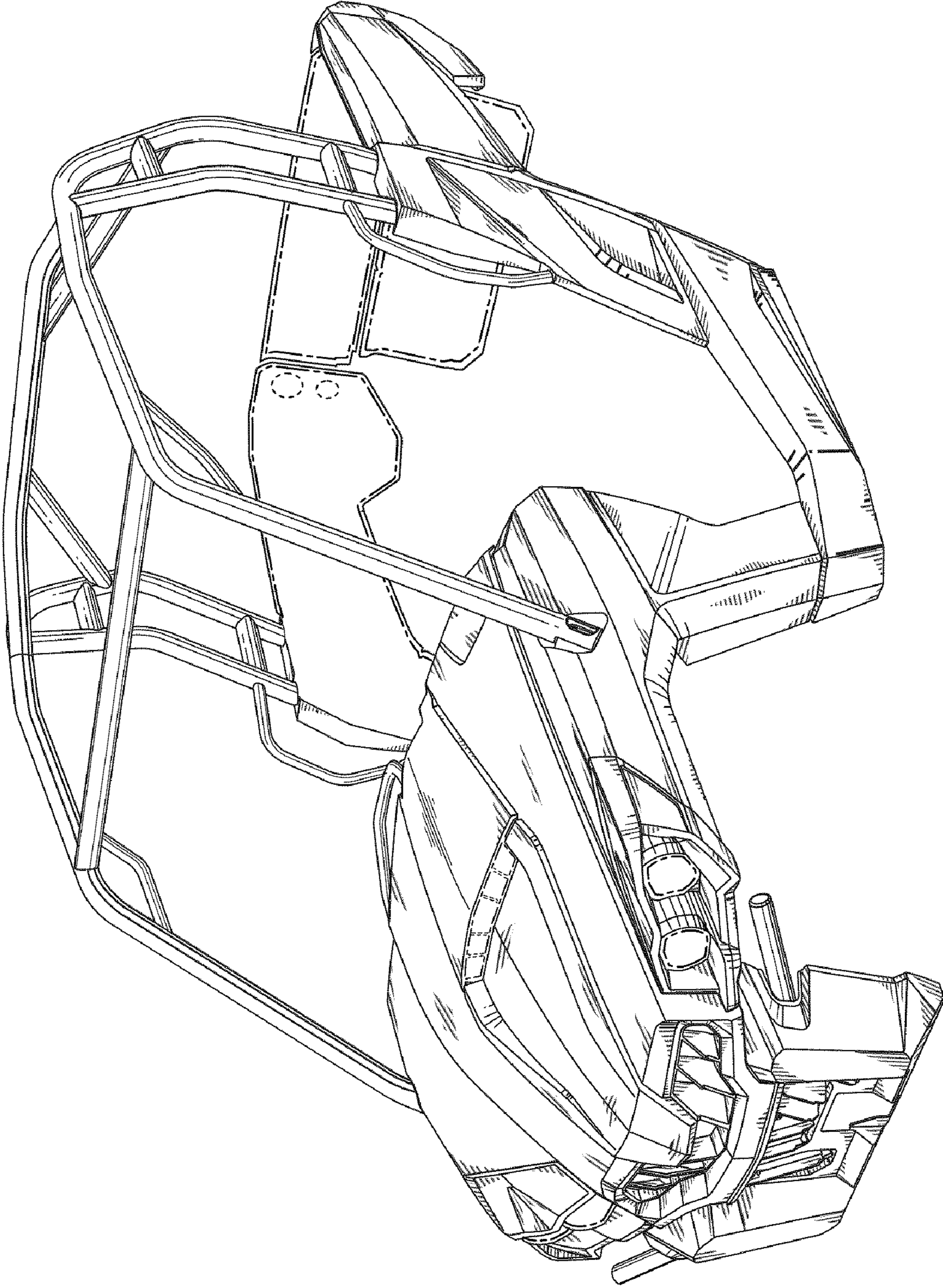

Fig. 21

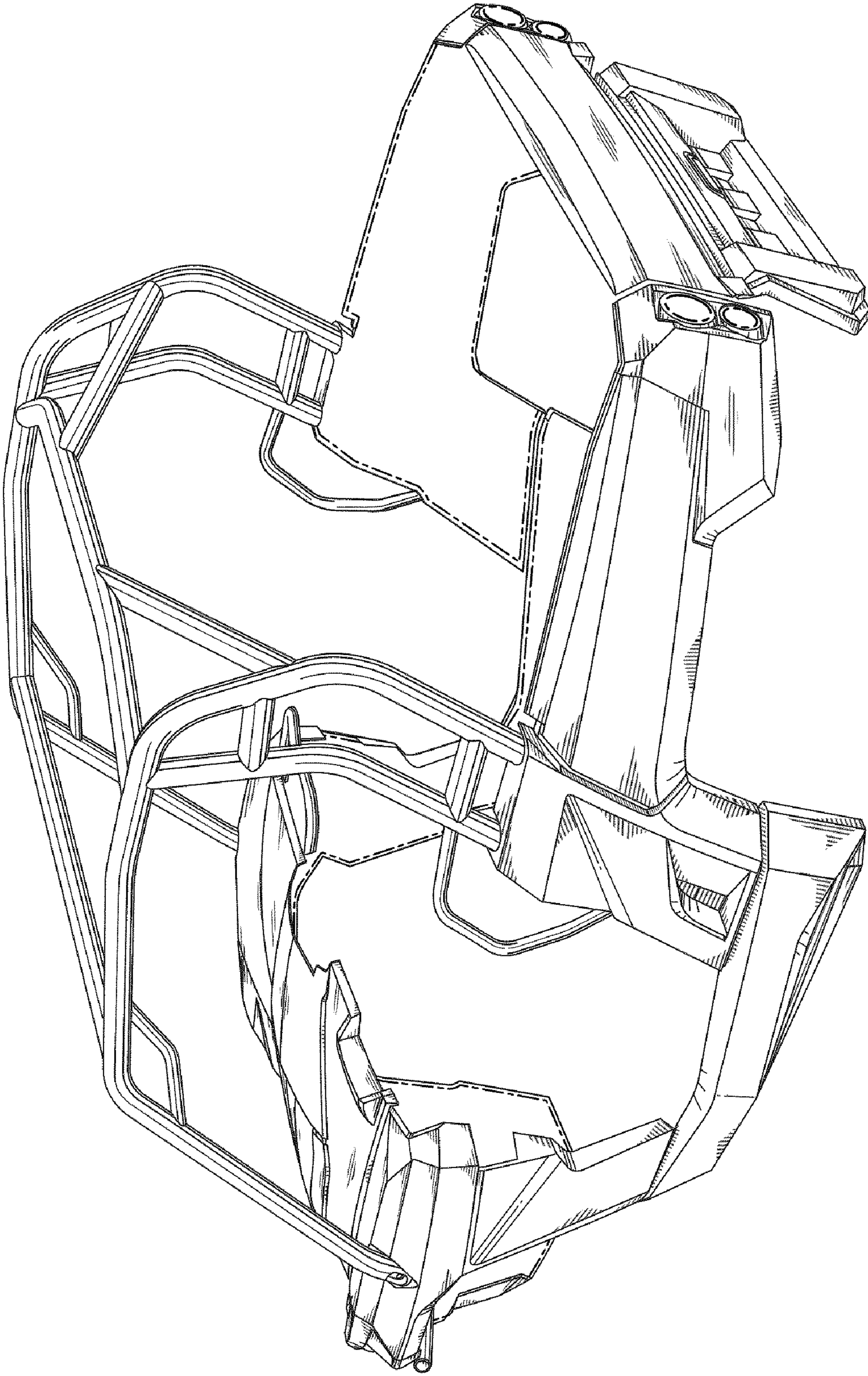

Fig.22

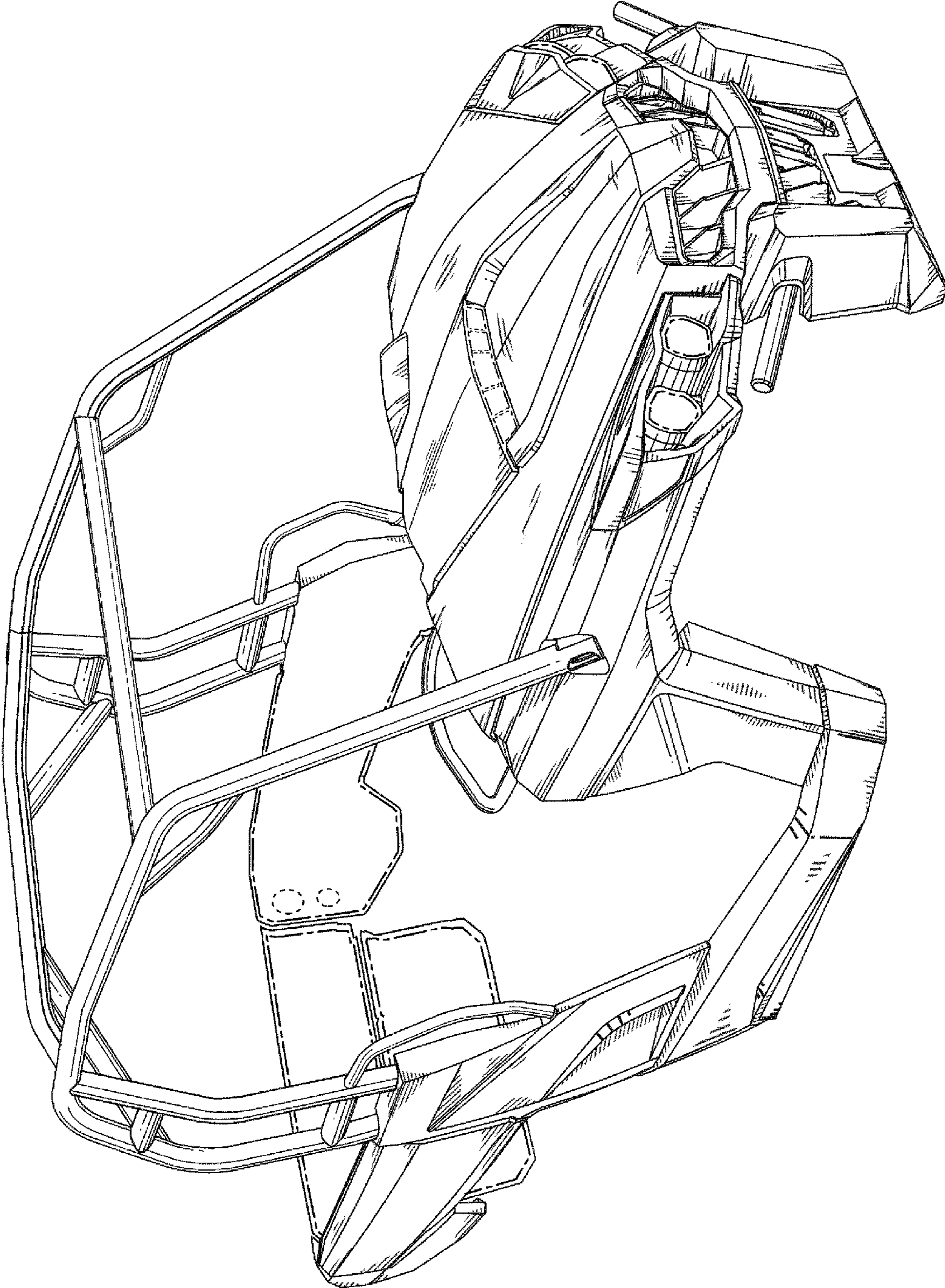

Fig. 23

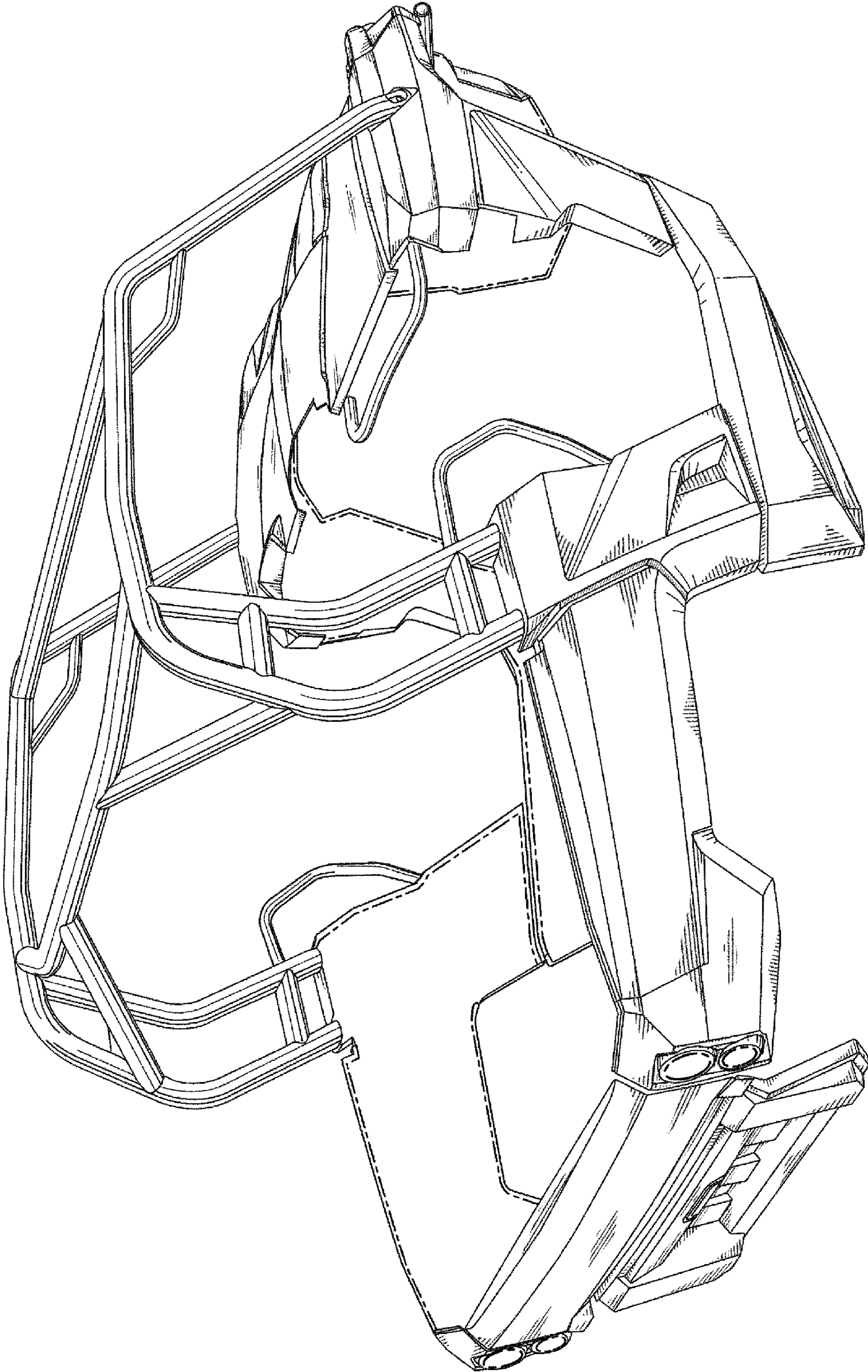

Fig. 24

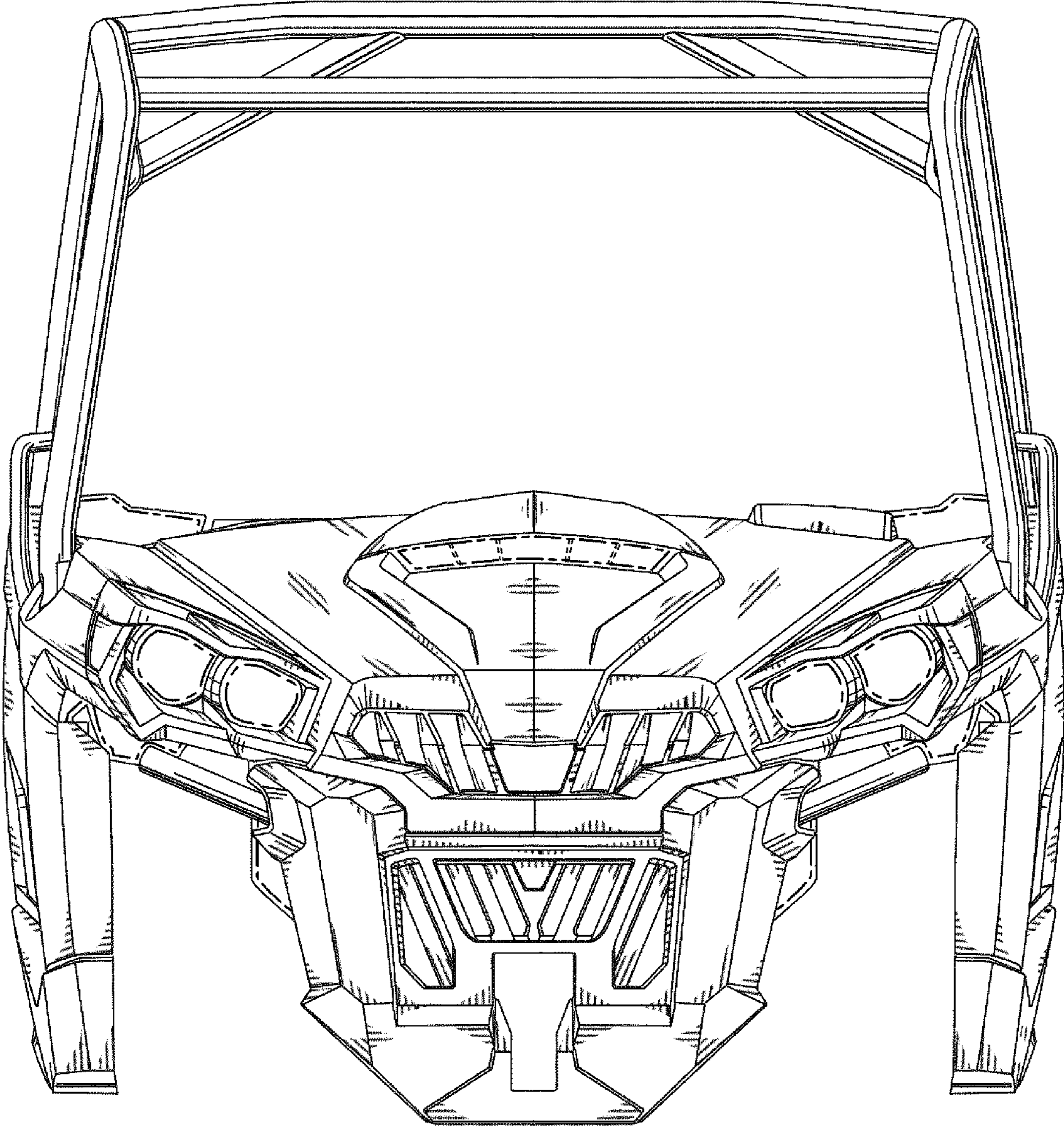

Fig.25

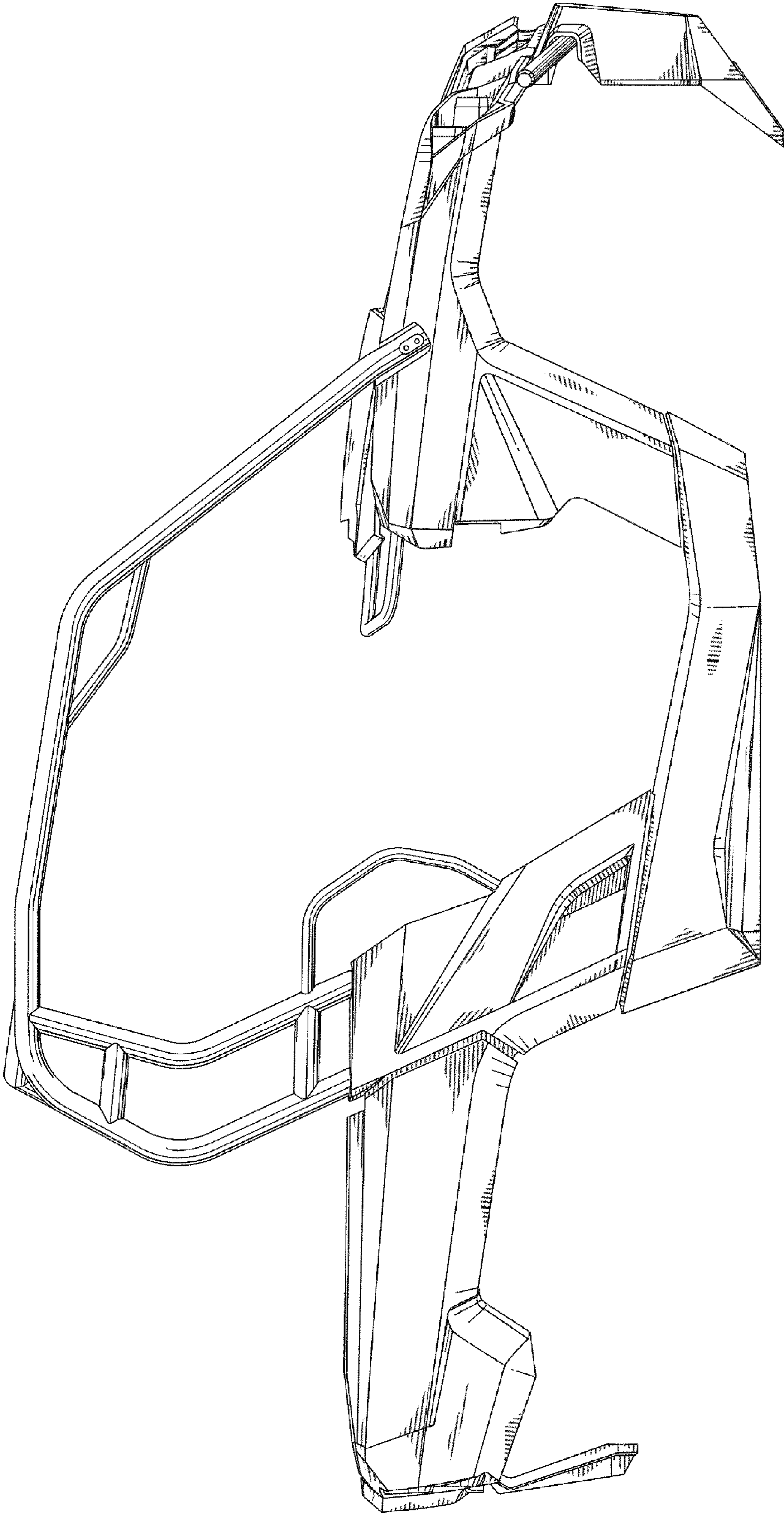

Fig.26

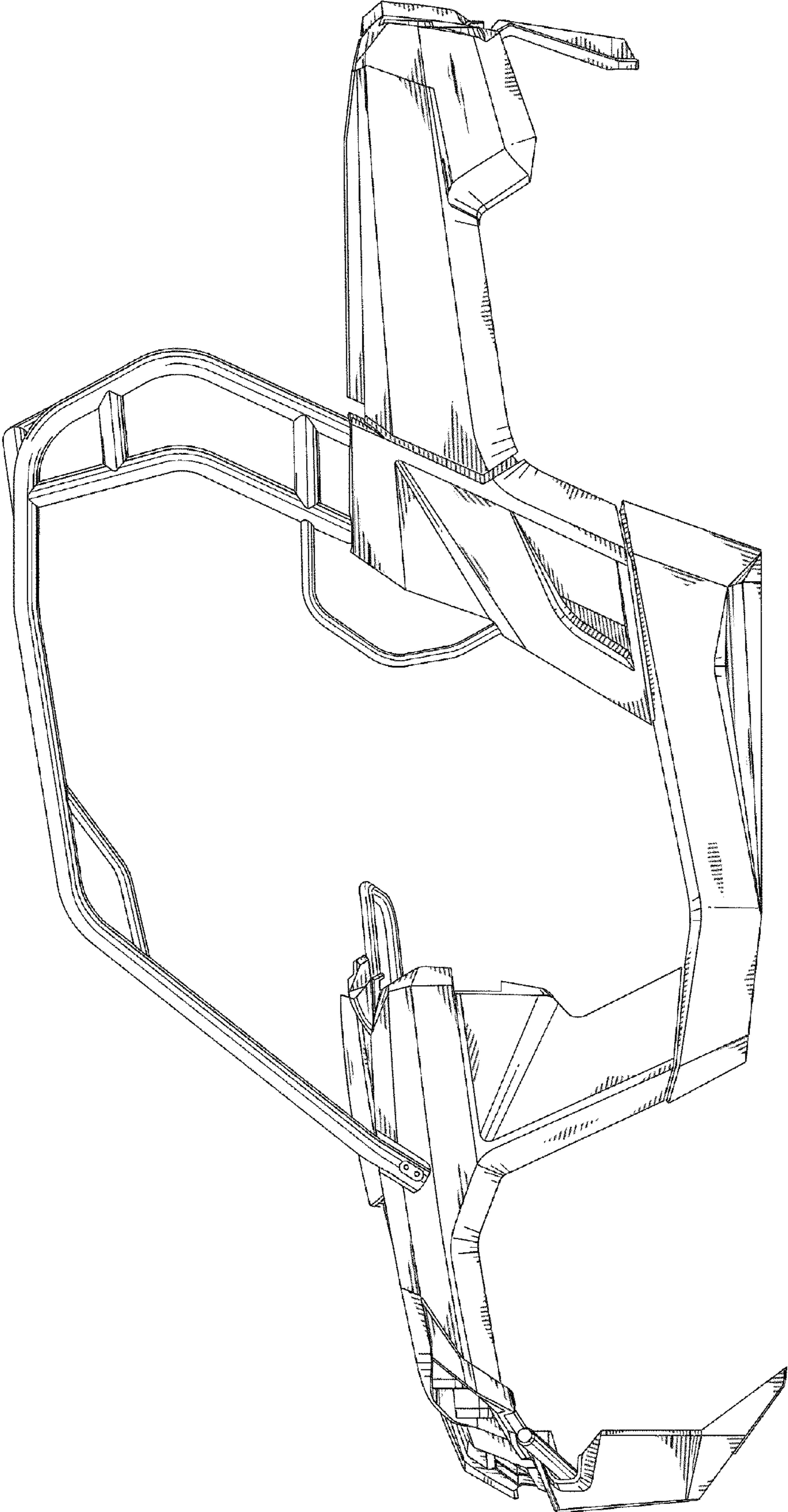

Fig.27

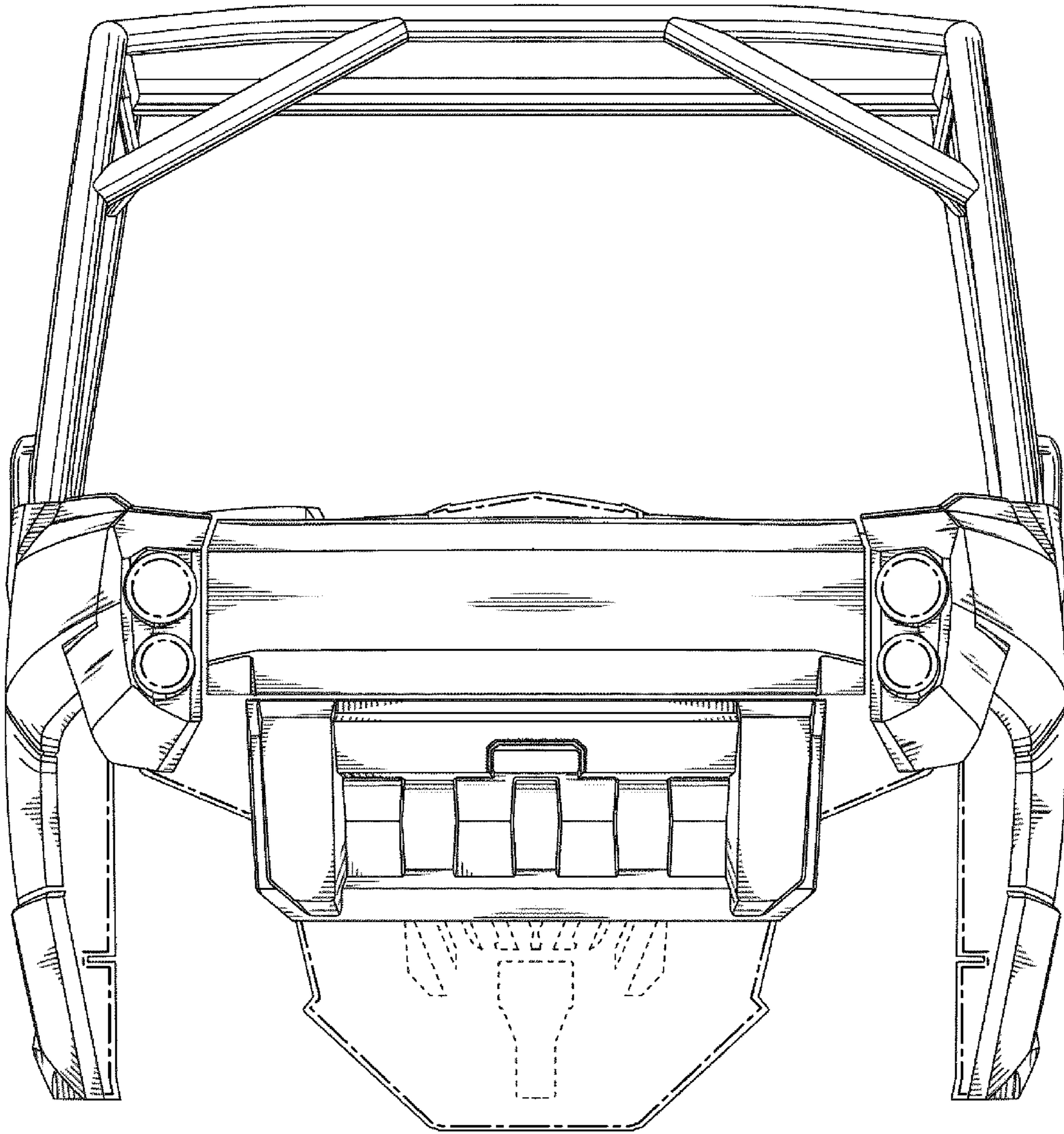

Fig.28

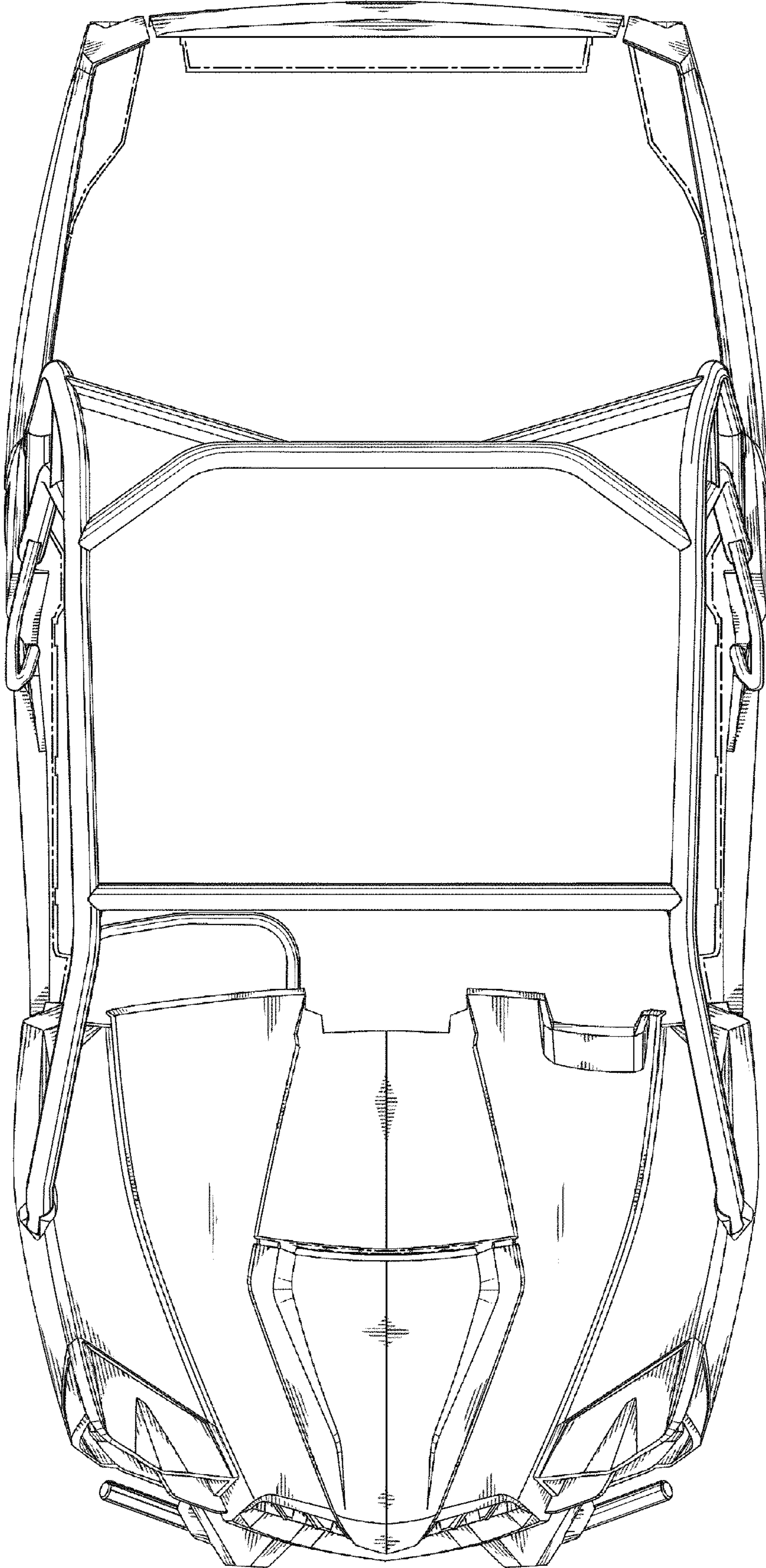

Fig. 29

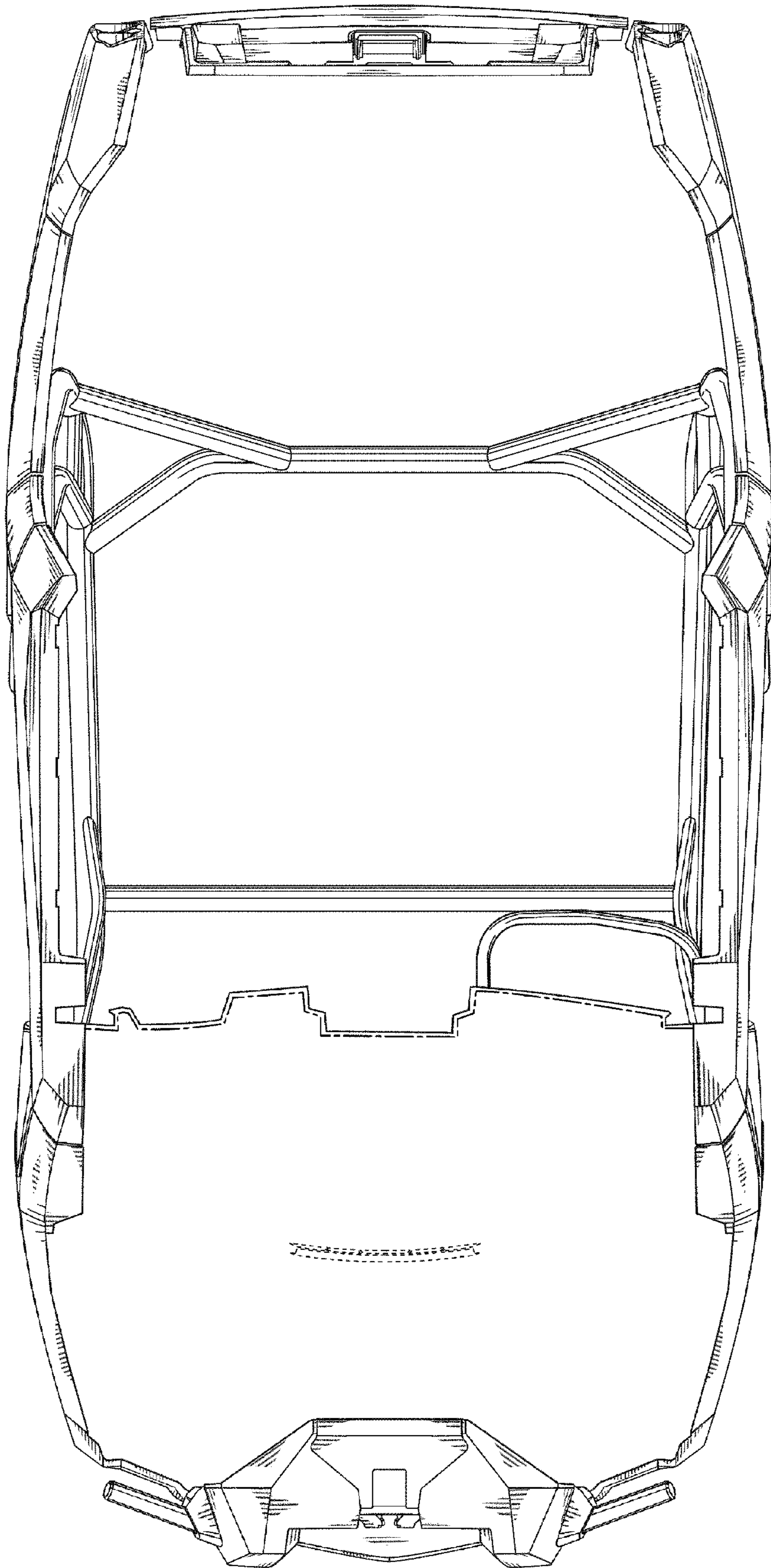

Fig.30