



US00D632969S

(12) **United States Design Patent**
Monteparo et al.

(10) **Patent No.:** **US D632,969 S**
(45) **Date of Patent:** **** Feb. 22, 2011**

(54) **BOTTLE**

(75) Inventors: **Sandra Monteparo**, Brooklyn, NY (US); **Sunnie Guglielmo**, Long Island City, NY (US); **Christine McKee**, New York, NY (US)

(73) Assignee: **Victoria's Secret Stores Brand Management, Inc.**, Reynoldsburg, OH (US)

(**) Term: **14 Years**

(21) Appl. No.: **29/349,618**

(22) Filed: **Apr. 16, 2010**

(51) **LOC (9) Cl.** **09-01**

(52) **U.S. Cl.** **D9/544; D9/559; D9/567; D9/573; D9/575; D9/444**

(58) **Field of Classification Search** D9/439, D9/44, 441, 541, 544, 546, 559-560, 566, D9/567-568, 572-575, 682, 694; D7/598; D28/91.1; 215/355, 382; 220/660, 662, 220/669

See application file for complete search history.

(56) **References Cited**

U.S. PATENT DOCUMENTS

D71,782 S	1/1927	Delaize	
D86,566 S	3/1932	Gibson	
D94,153 S	12/1934	Levine	
D98,382 S *	1/1936	Barbiers	D9/563
D120,147 S *	4/1940	Steuer	D9/568
D123,204 S *	10/1940	Carey	D9/566
D143,657 S	1/1946	Graham	
D194,809 S	3/1963	Du Pree	
D211,625 S *	7/1968	Du Pree	D7/300
D247,282 S *	2/1978	Zimmermann	D9/521
D278,410 S *	4/1985	Matsubara et al.	D9/563
D278,515 S	4/1985	Adams et al.	
D285,054 S *	8/1986	Stones	D9/542

D333,269 S	2/1993	Albright et al.	
D366,620 S *	1/1996	Kuzma et al.	D9/542
D420,596 S *	2/2000	Maddy	D9/560
D444,071 S	6/2001	Mansau	
D526,567 S	8/2006	Dalton	
D530,211 S	10/2006	Lloyd	
D531,911 S	11/2006	Lloyd	
D574,257 S *	8/2008	Zeidan	D9/694
D610,916 S *	3/2010	Yeung et al.	D9/694
D612,259 S	3/2010	Legros	
D620,804 S *	8/2010	Bogert et al.	D9/544

OTHER PUBLICATIONS

Trademark Registration No. 1,070,454, by Shower Mate Corporation, Registered on Jul. 26, 1977.

* cited by examiner

Primary Examiner—Charles A Rademaker

Assistant Examiner—Dana L Sipos

(74) *Attorney, Agent, or Firm*—Ward & Olivo

(57) **CLAIM**

The ornamental design for a bottle, as shown and described.

DESCRIPTION

FIG. 1 is a perspective view of a bottle;

FIG. 2 is a front view thereof;

FIG. 3 is a rear view thereof;

FIG. 4 is a right side view thereof, the left side being a mirror image thereof;

FIG. 5 is a top view thereof; and,

FIG. 6 is a bottom view thereof.

The stripes applied to the rear of the bottle represent opaque contrast on the rear sidewall surfaces.

The broken lines shown in the figures are for illustrative purposes only and form no part of the claimed design.

1 Claim, 4 Drawing Sheets

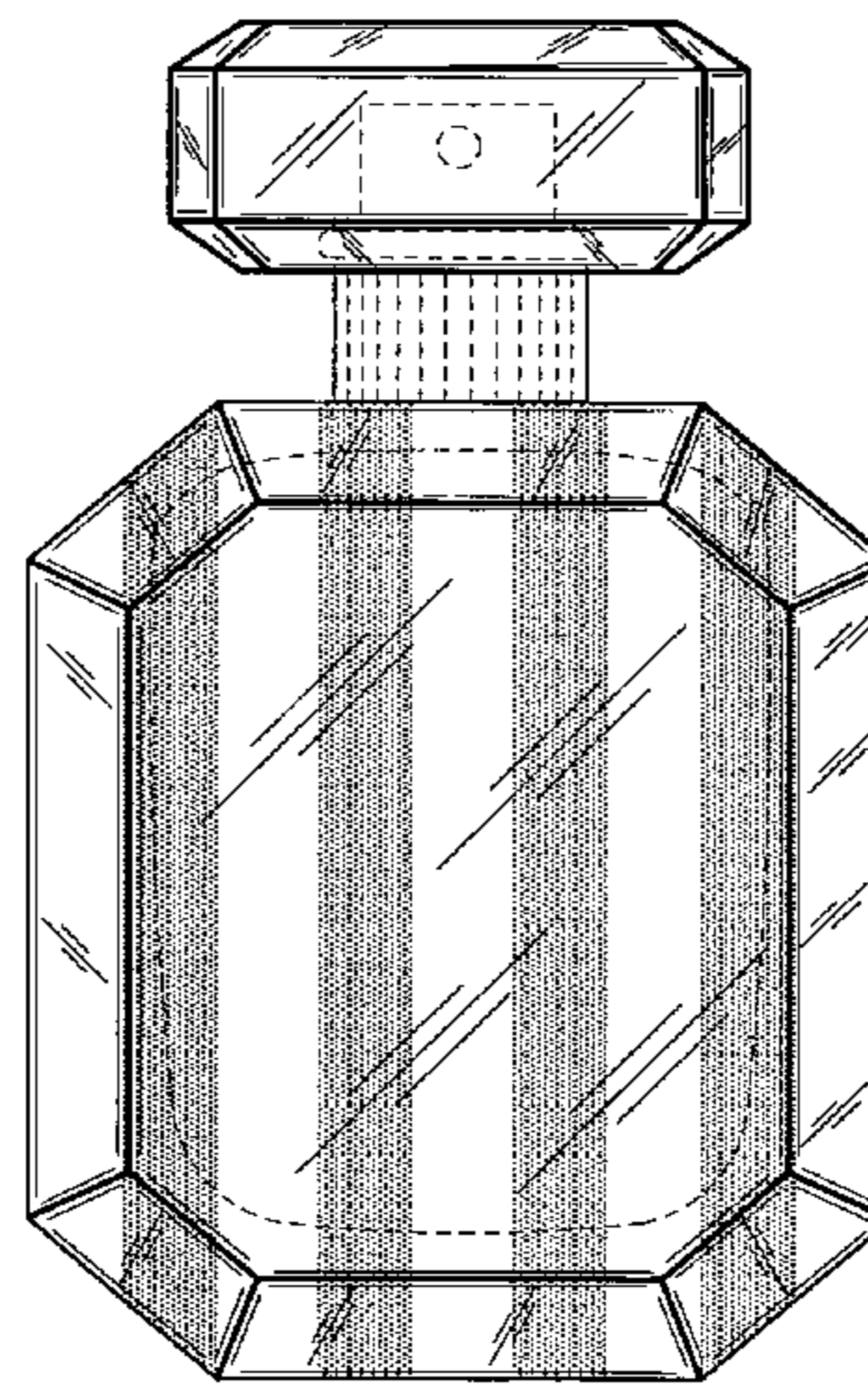
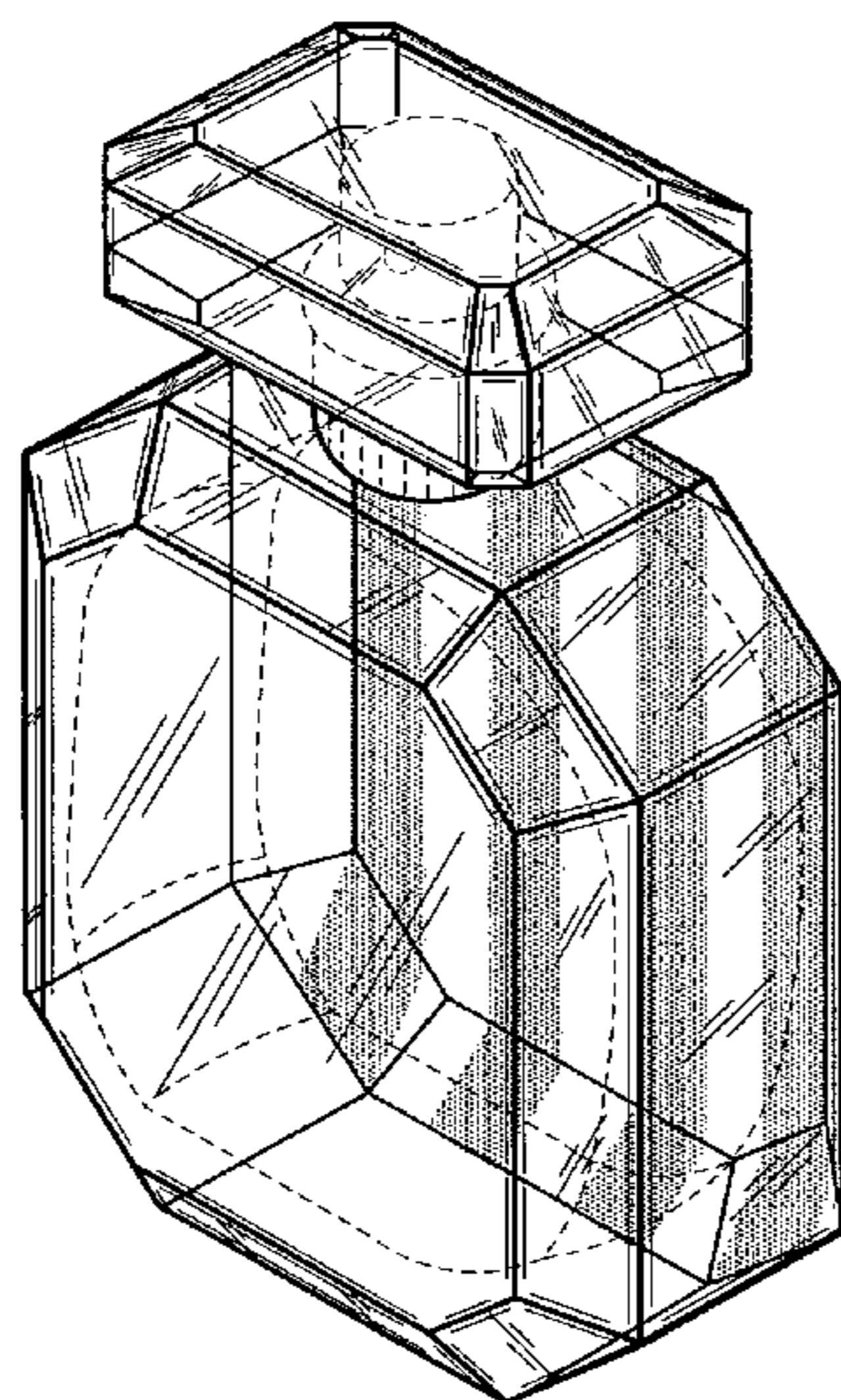

FIG. 1

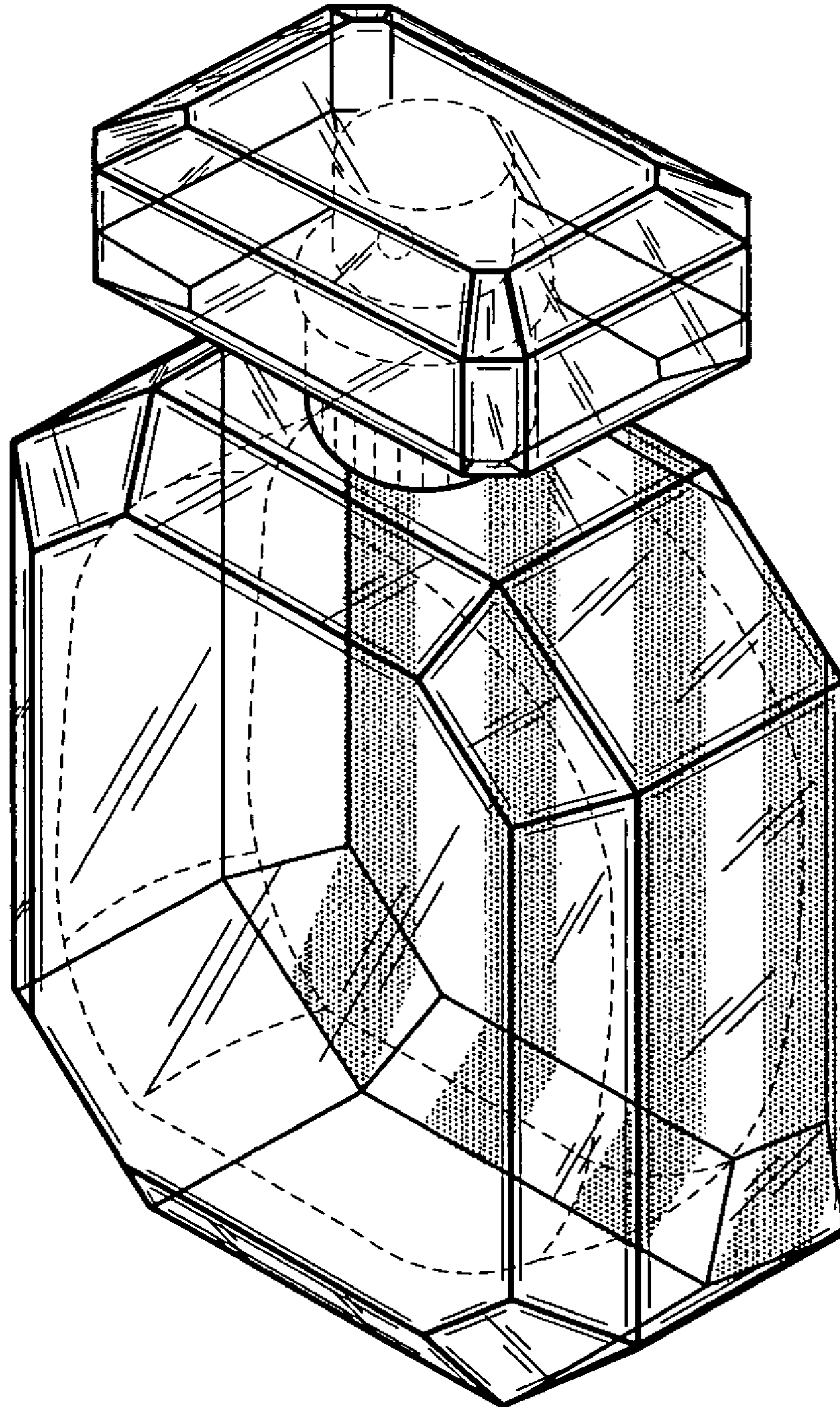

FIG. 2

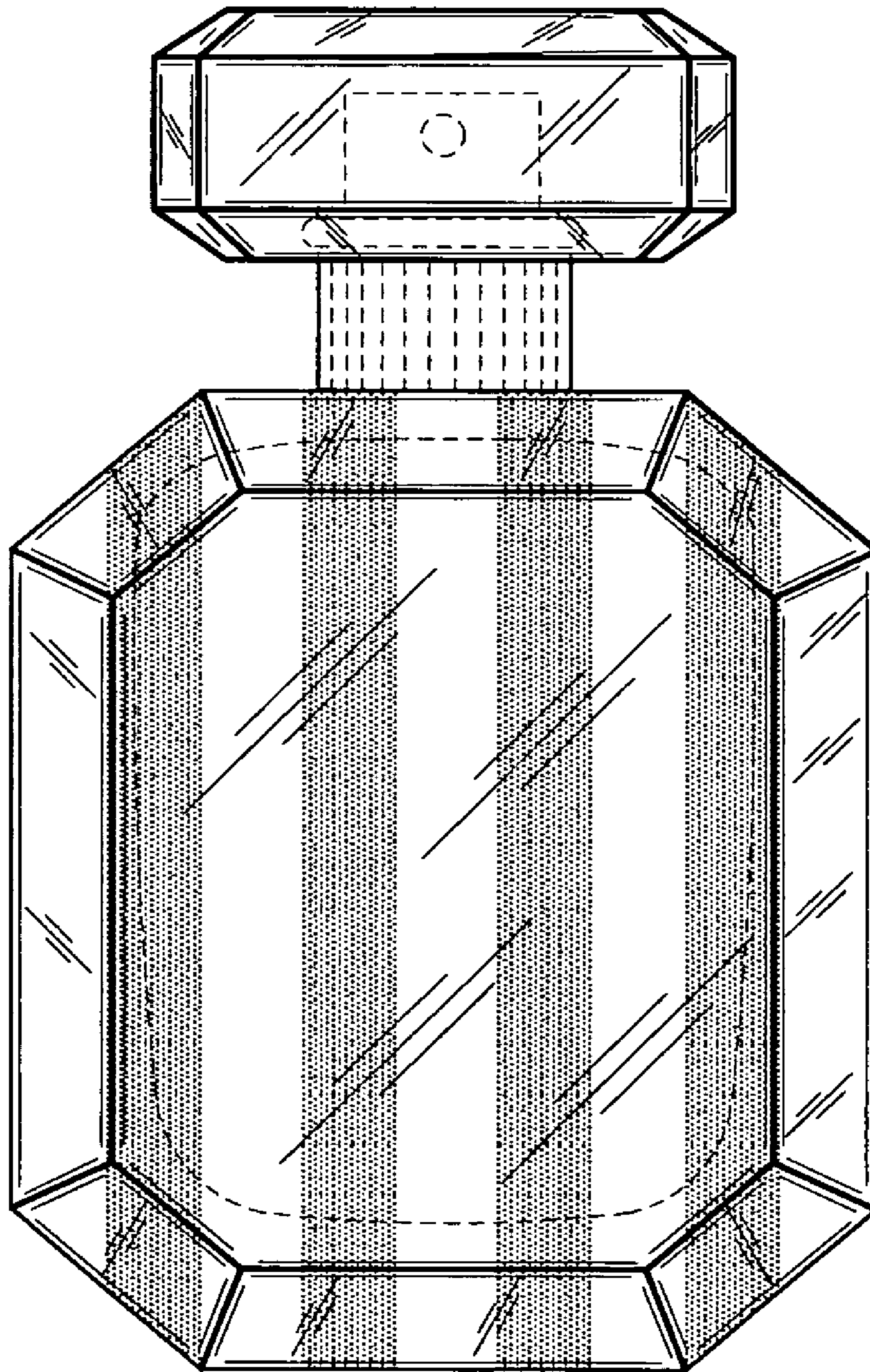

FIG. 3

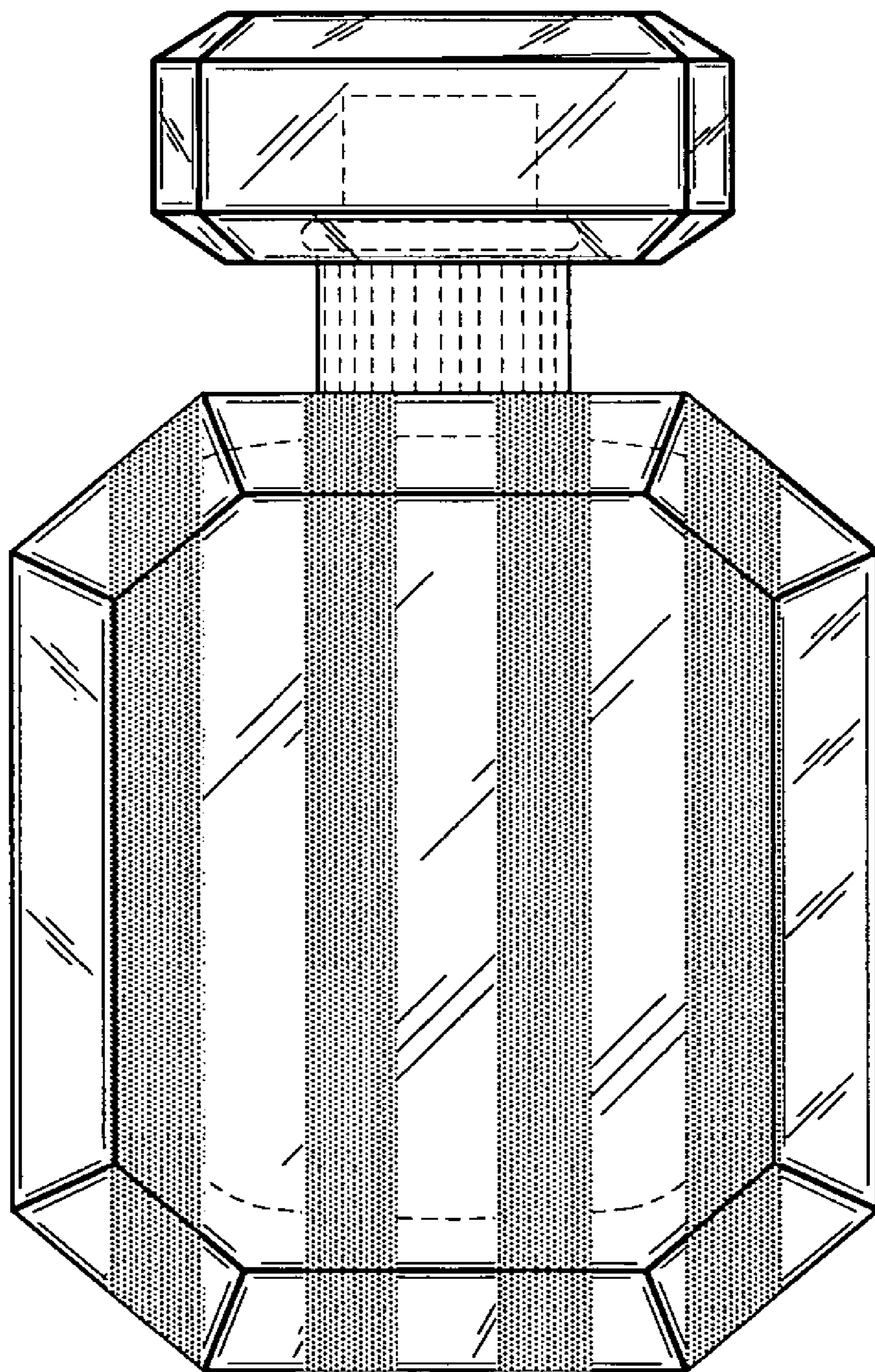

FIG. 4

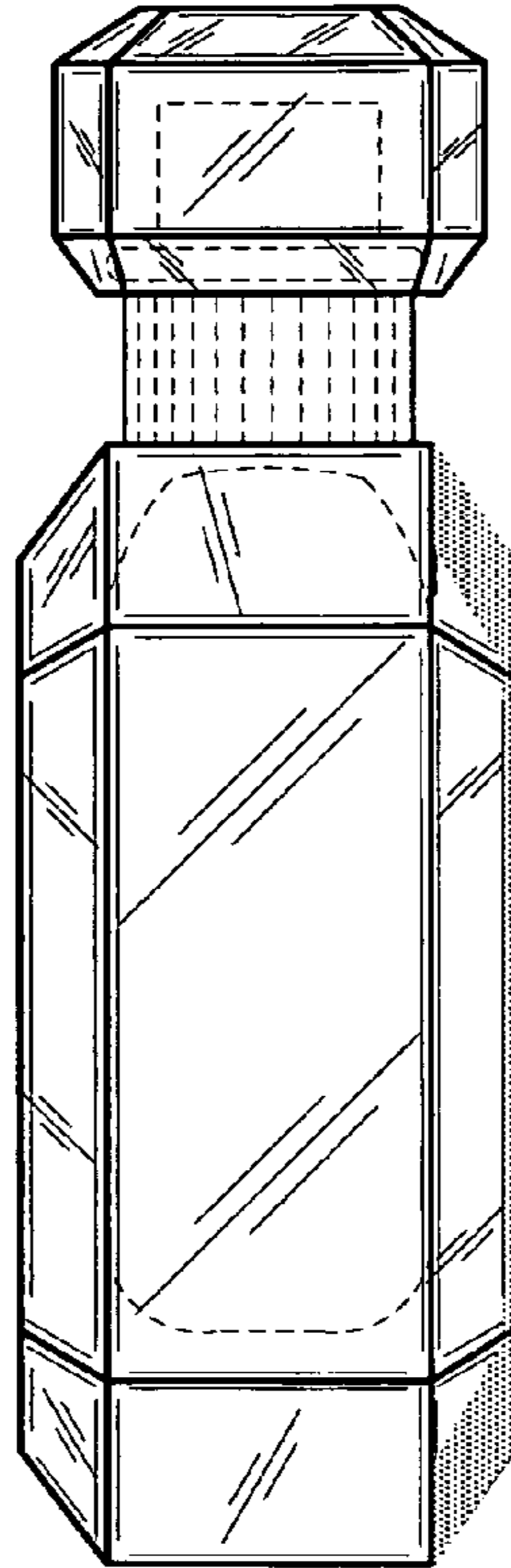

FIG. 5

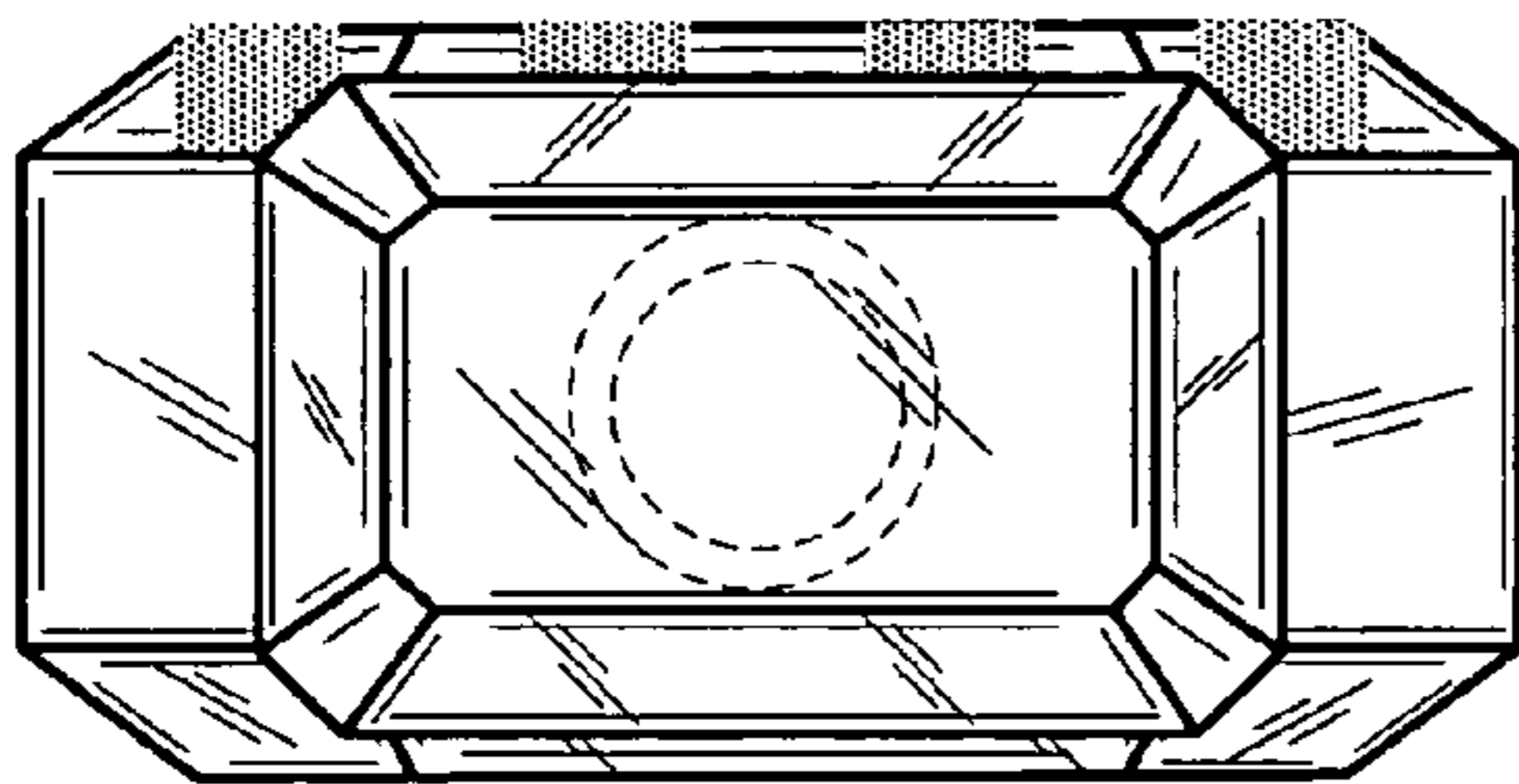

FIG. 6

