



US00D632641S

(12) **United States Design Patent**
Sato

(10) **Patent No.:** **US D632,641 S**
(45) **Date of Patent:** **** Feb. 15, 2011**

(54) **AUTOMOBILE TIRE**

(75) Inventor: **Yoshiki Sato**, Osaka (JP)

(73) Assignee: **Toyo Tire & Rubber Co., Ltd.**,
Osaka-shi (JP)

(**) Term: **14 Years**

(21) Appl. No.: **29/368,792**

(22) Filed: **Aug. 30, 2010**

(30) **Foreign Application Priority Data**

Jul. 5, 2010 (JP) 2010-016317

(51) **LOC (9) Cl.** **12-15**

(52) **U.S. Cl.** **D12/605**

(58) **Field of Classification Search** D12/500–501,
D12/544, 579, 600, 605, 604; 152/523–524,
152/DIG. 12, 555; D7/588, 396.4–396.5
See application file for complete search history.

(56) **References Cited**

U.S. PATENT DOCUMENTS

- D450,034 S * 11/2001 Kajikawa D12/605
- D452,203 S * 12/2001 Kajikawa D12/605
- D541,211 S * 4/2007 Shondel et al. D12/605
- D543,933 S * 6/2007 Shondel D12/605
- D584,222 S * 1/2009 Ohashi D12/605
- D593,487 S * 6/2009 Takahashi D12/605
- D608,275 S * 1/2010 Maxwell D12/605

D626,502 S * 11/2010 Nakamura D12/605

FOREIGN PATENT DOCUMENTS

JP 1366846 S 8/2009

* cited by examiner

Primary Examiner—Stacia Cadmus

(74) *Attorney, Agent, or Firm*—Westerman, Hattori, Daniels & Adrian, LLP

(57) **CLAIM**

The ornamental design for an automobile tire, as shown and described.

DESCRIPTION

FIG. 1 is a front elevation view of an automobile tire showing my new design;

FIG. 2 is a rear elevation view thereof;

FIG. 3 is a left-side elevation view thereof;

FIG. 4 is a top plan view thereof;

FIG. 5 is a perspective view thereof;

FIG. 6 is an enlarged view taken along line 6—6 in FIG. 1 thereof; and,

FIG. 7 is an enlarged cross-sectional view along the line 7—7 in FIG. 6, in the area designated by “B” in FIG. 4 and “C” in FIG. 6.

The broken lines illustrate environmental structure and form no part of the claimed design.

1 Claim, 7 Drawing Sheets

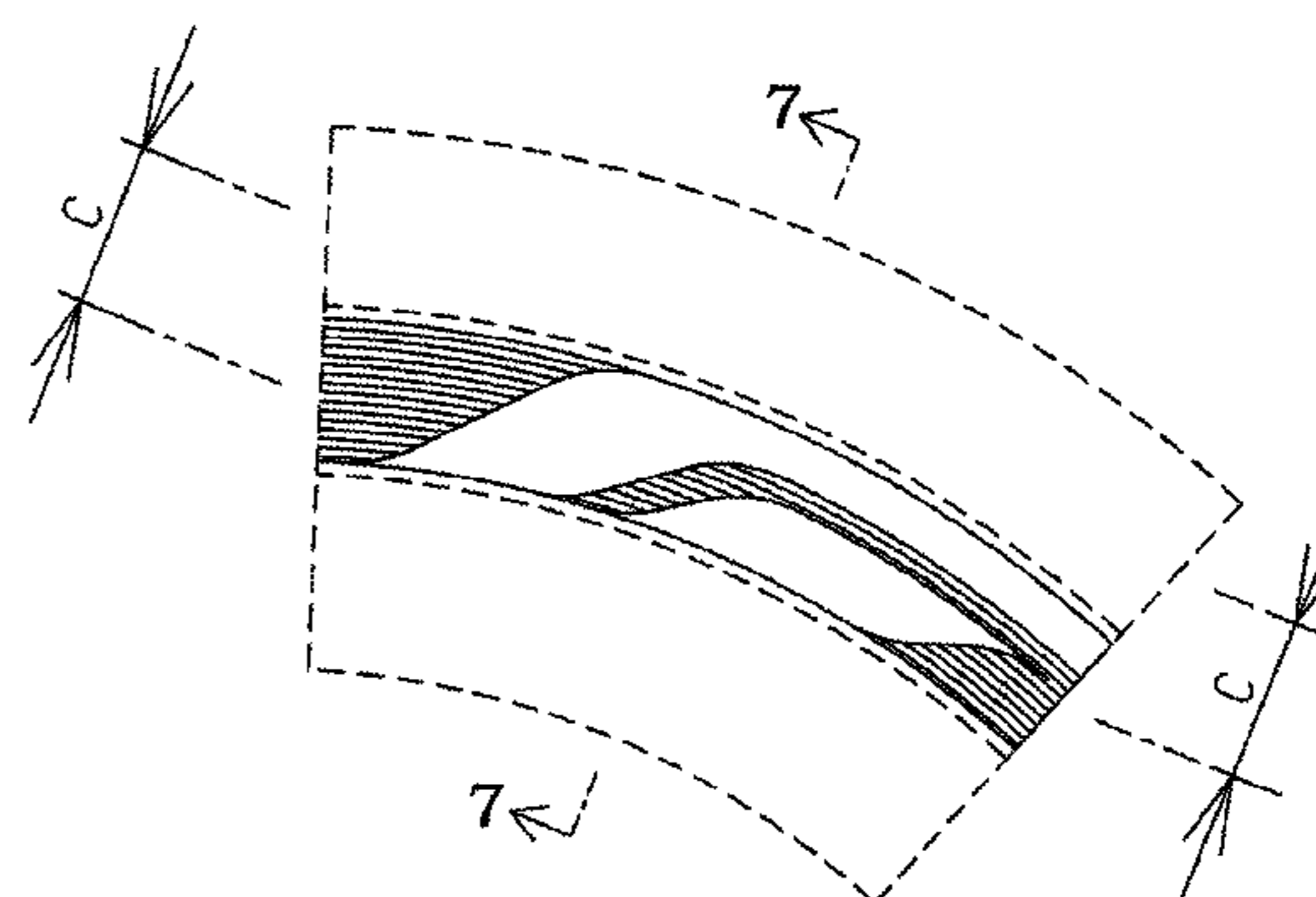
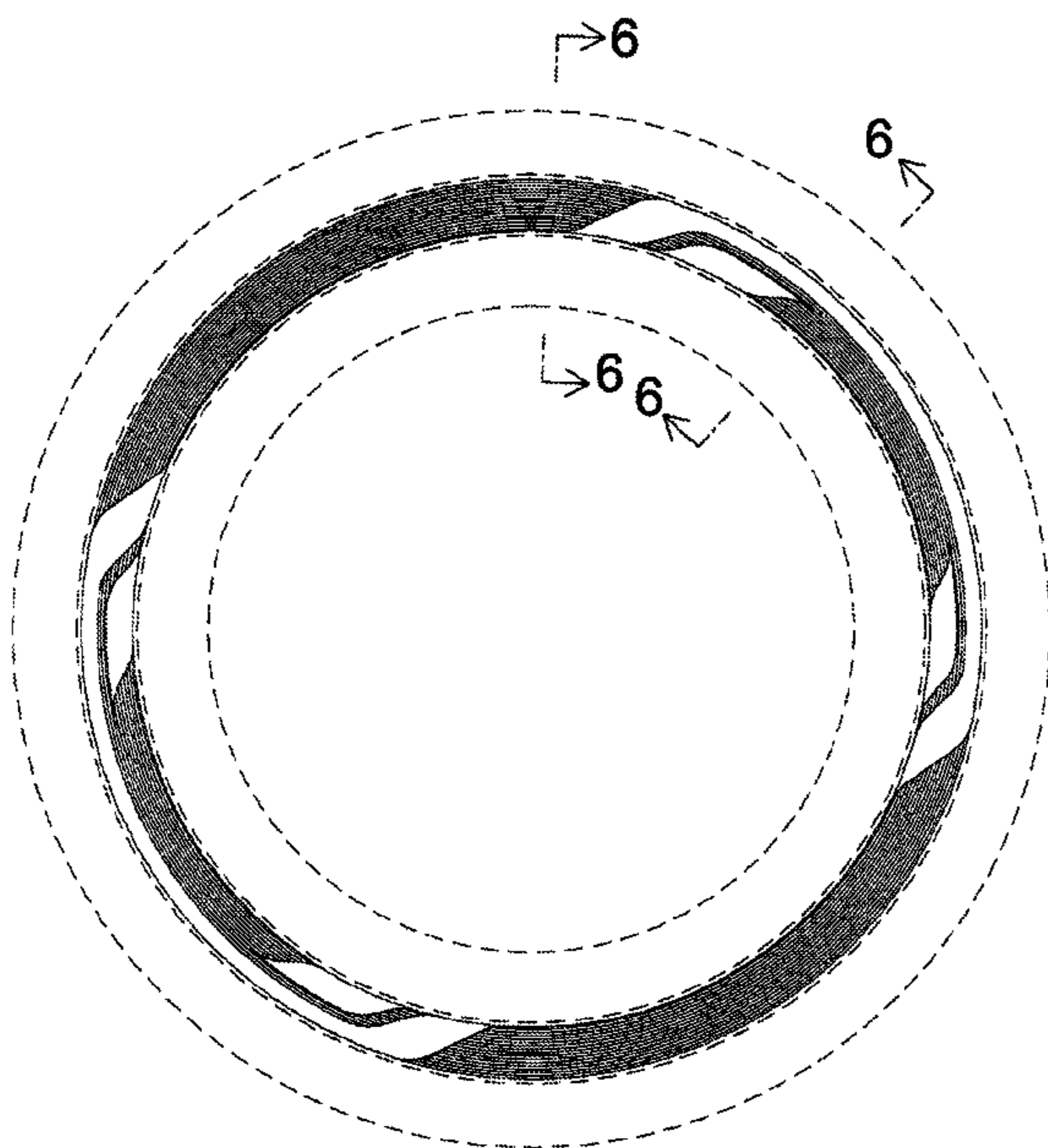

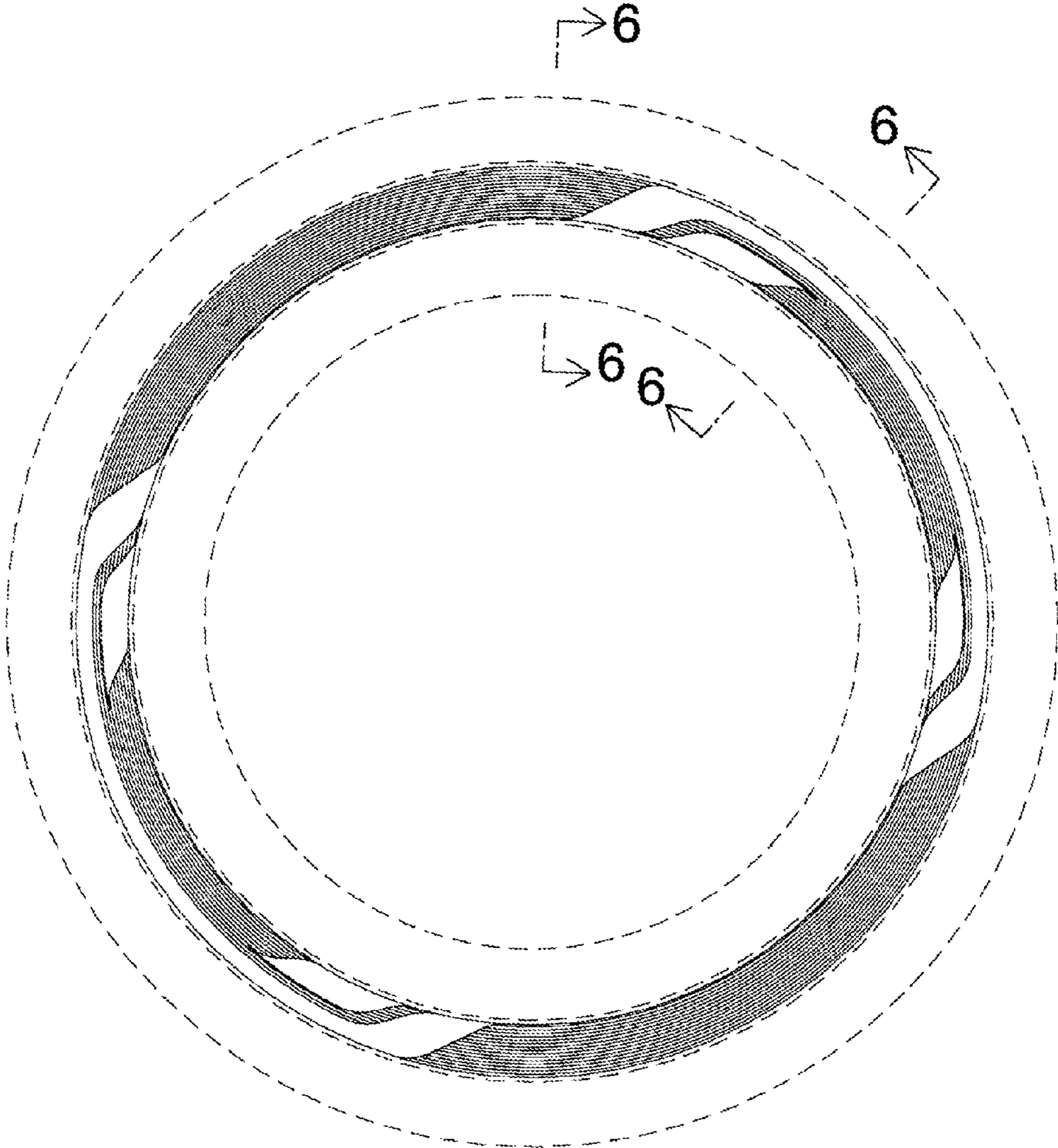

FIG.1

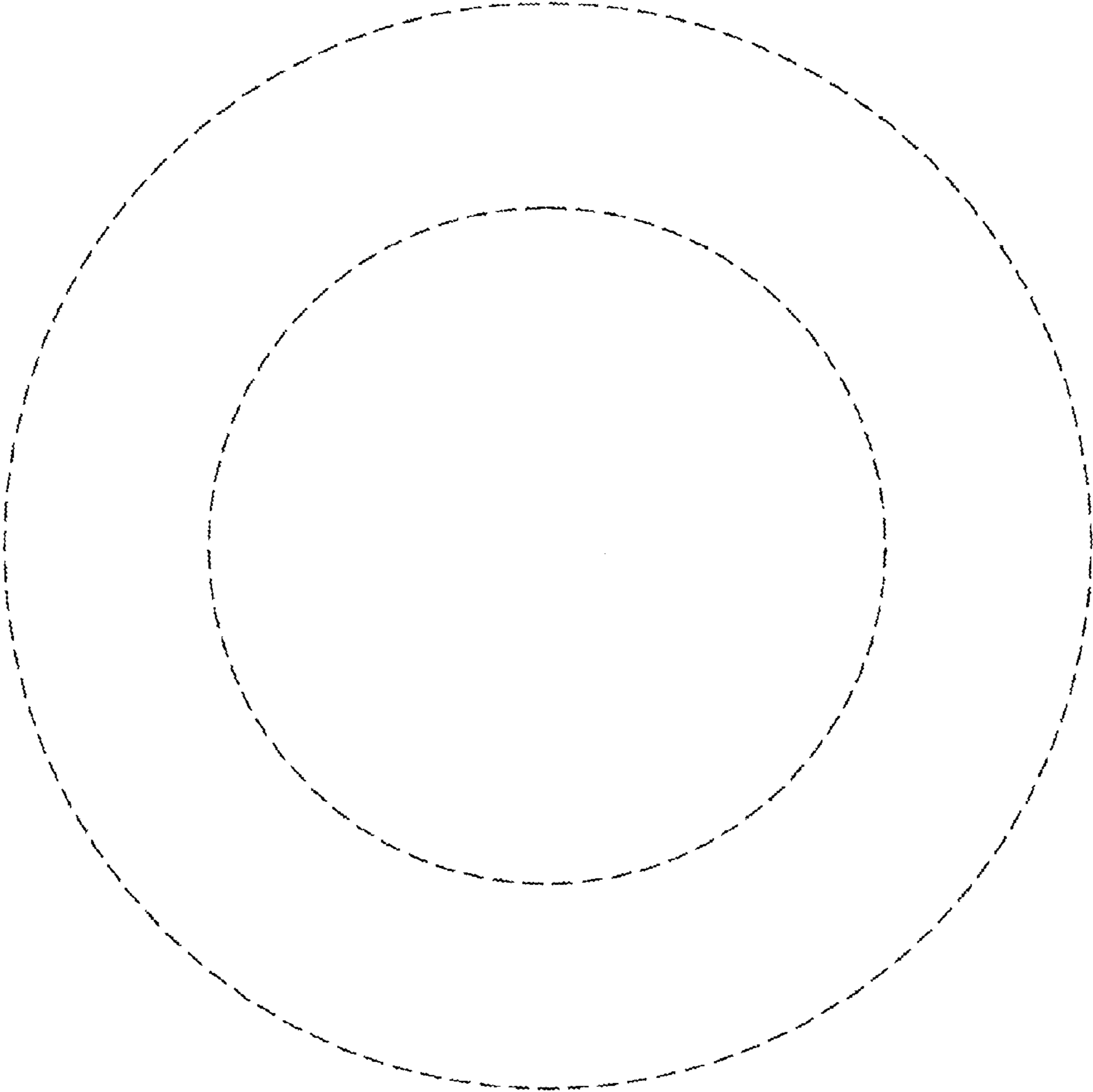

FIG.2

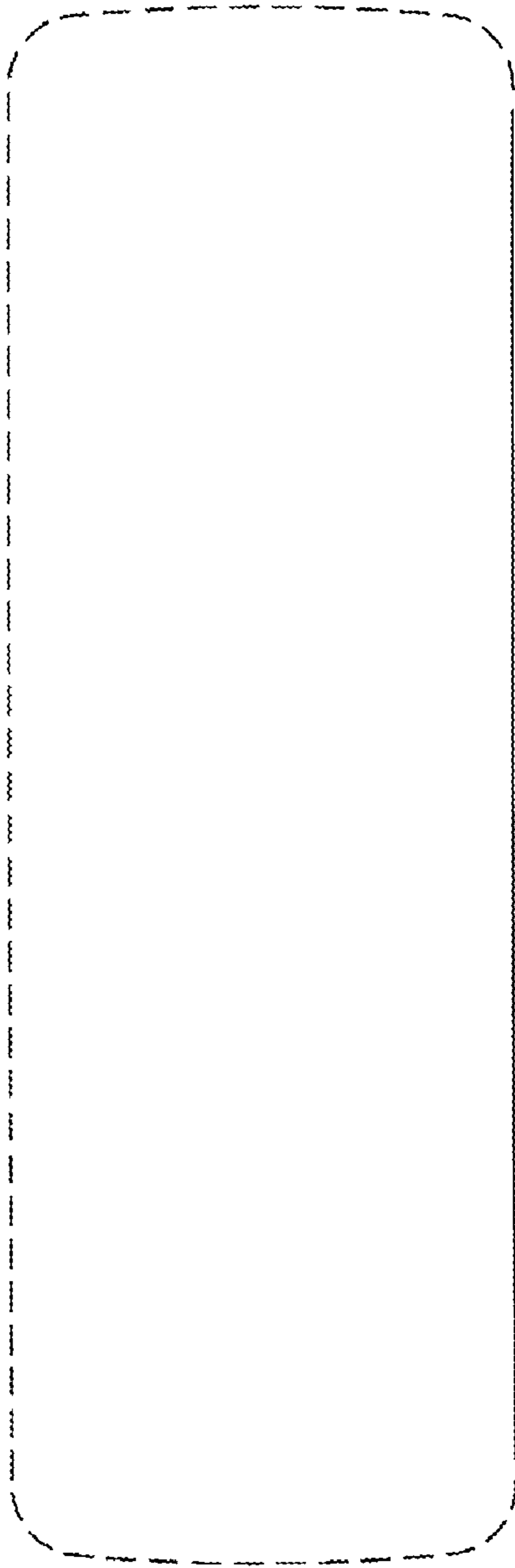

FIG.3

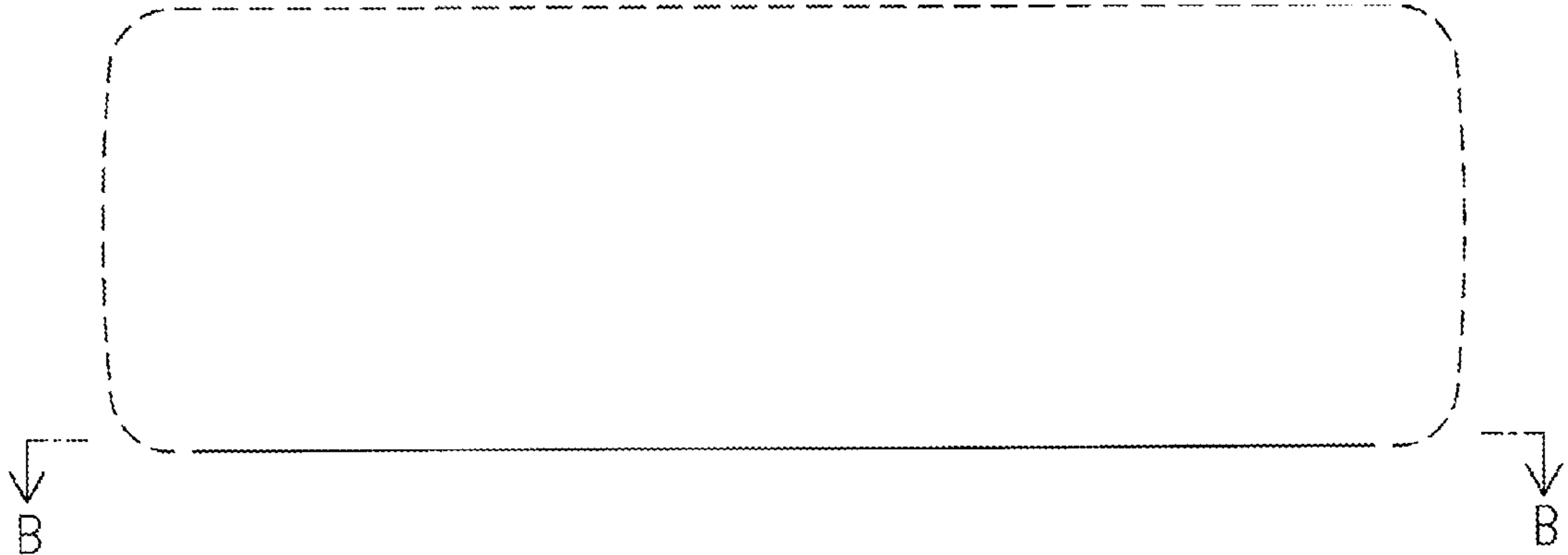

FIG.4

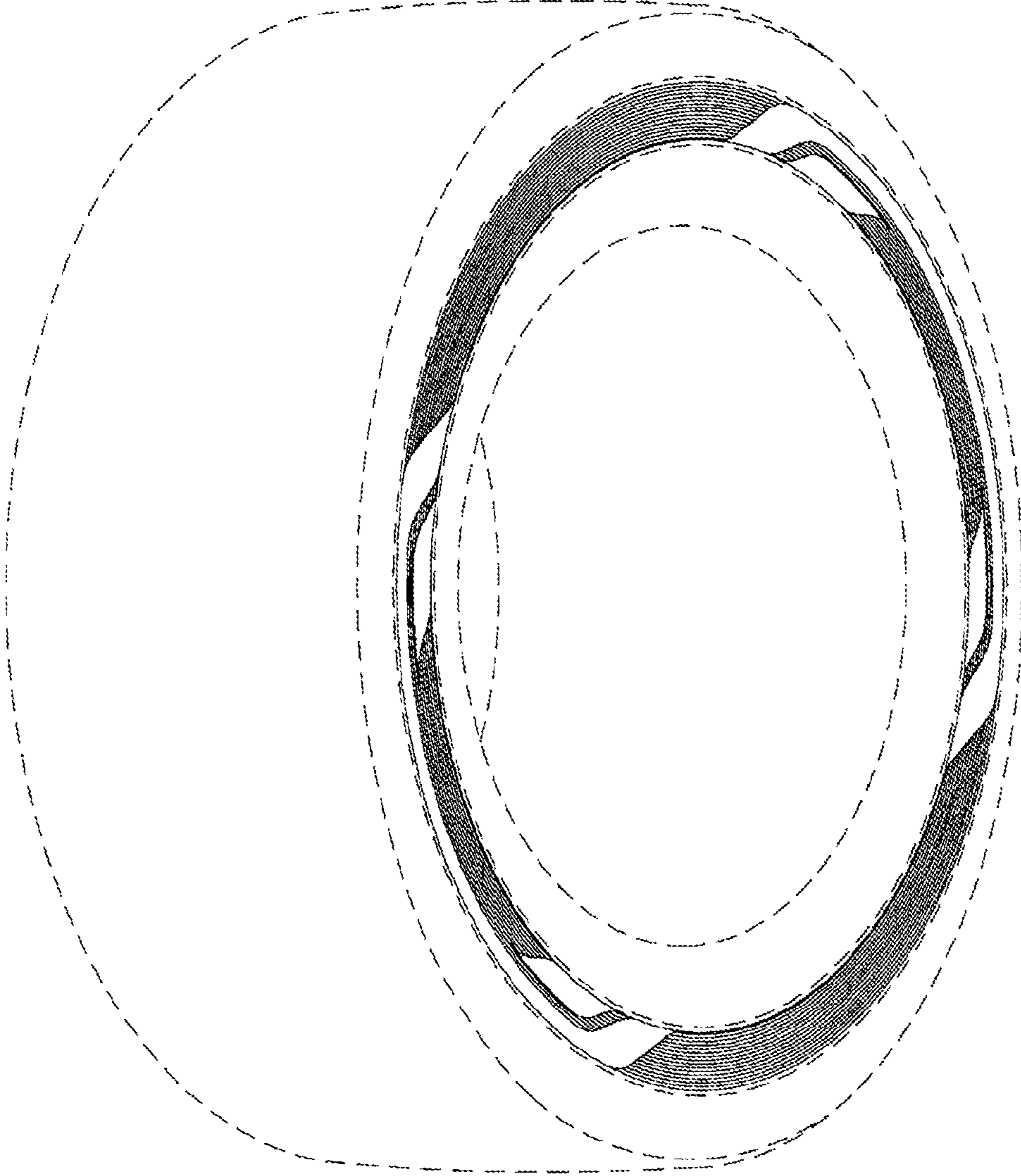

FIG.5

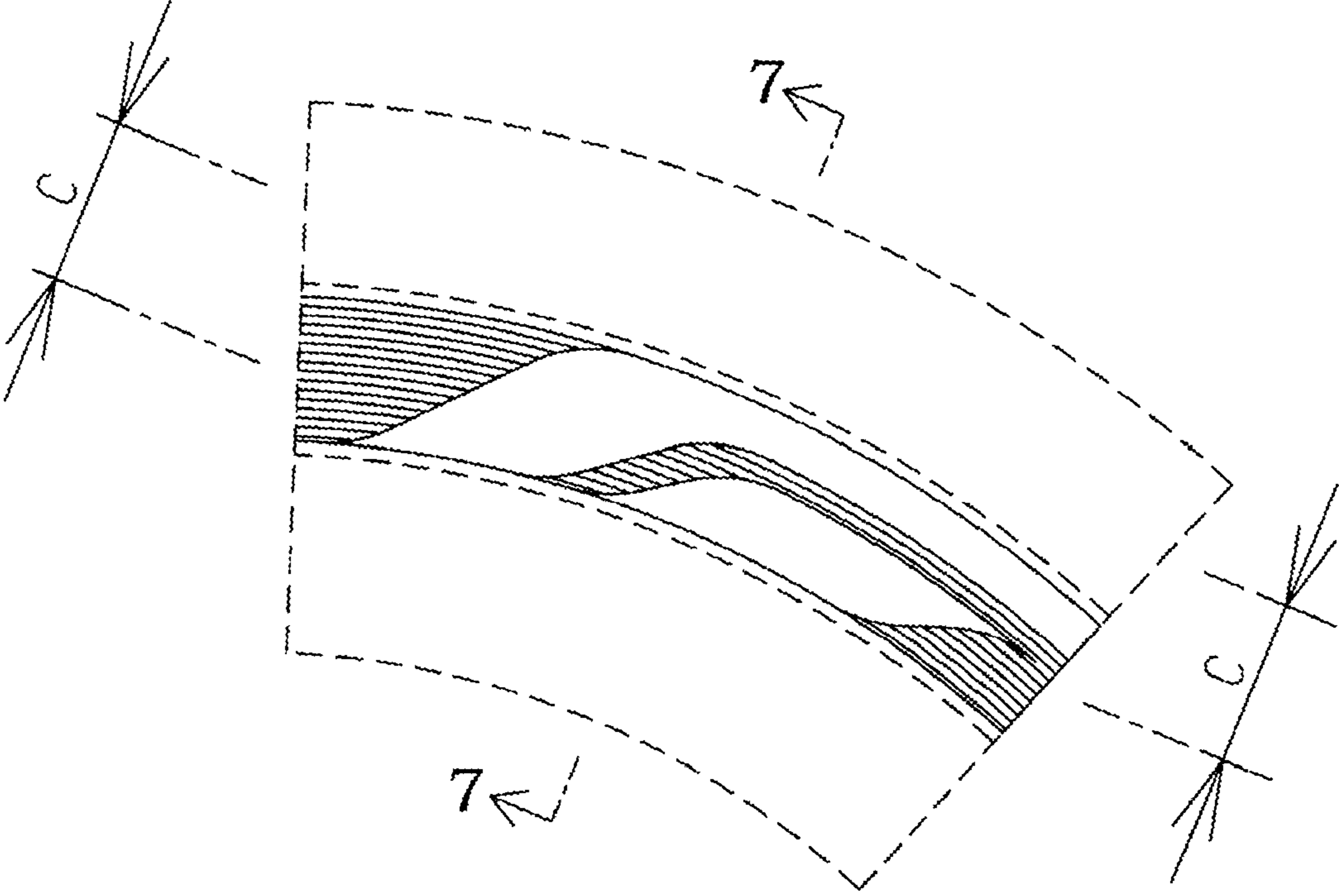

FIG.6



FIG.7