



US00D632622S

(12) **United States Design Patent**
Fujioka et al.

(10) **Patent No.:** **US D632,622 S**

(45) **Date of Patent:** **** Feb. 15, 2011**

- (54) **VEHICLE CONTROL PANEL**
- (75) Inventors: **Devon Jay Fujioka**, Los Angeles, CA
(US); **Ildefonso Burgos**, Orange, CA
(US)
- (73) Assignee: **Honda Motor Co., Ltd.**, Tokyo (JP)
- (**) Term: **14 Years**
- (21) Appl. No.: **29/363,651**
- (22) Filed: **Jun. 11, 2010**
- (51) **LOC (9) Cl.** **12-16**
- (52) **U.S. Cl.** **D12/192**
- (58) **Field of Classification Search** D12/192,
D12/415, 110, 114; 180/90; 280/750-752;
296/190.01-190.09, 191, 70; D15/17, 28;
D10/46, 98, 102-103, 122-127
See application file for complete search history.

D535,926 S *	1/2007	Anderson et al.	D12/192
D556,658 S *	12/2007	Kanda et al.	D12/192
D558,109 S *	12/2007	Misugi et al.	D12/192
D561,077 S *	2/2008	Kato	D12/192
D571,270 S *	6/2008	Nakajima	D12/192
D578,048 S *	10/2008	Wyszogrod	D12/192
D586,278 S *	2/2009	Yu	D12/192
D613,653 S *	4/2010	Money Penny et al.	D12/192
D621,760 S *	8/2010	Wiedeman et al.	D12/192
2008/0100086 A1 *	5/2008	Vermeersch et al.	296/70
2009/0015031 A1 *	1/2009	Sato et al.	296/70

* cited by examiner

Primary Examiner—Caron Veynar

Assistant Examiner—Katrina A Kile

(74) *Attorney, Agent, or Firm*—Plumsea Law Group, LLC;
Mark E. Duell

(57) **CLAIM**

The ornamental design for a vehicle control panel, as shown and described.

DESCRIPTION

FIG. 1 is a perspective view of a vehicle control panel showing our new design; and,

FIG. 2 is a front elevational view thereof.

The broken line denotes a boundary of the claimed design and forms no part thereof.

1 Claim, 2 Drawing Sheets

(56) **References Cited**

U.S. PATENT DOCUMENTS

D443,246 S *	6/2001	Smith	D12/415
D449,026 S *	10/2001	Tsay et al.	D12/192
D474,137 S *	5/2003	Wyszogrod	D12/192
D494,909 S *	8/2004	Pfeiffer	D12/192
D503,367 S *	3/2005	Pfeiffer	D12/192
D512,356 S *	12/2005	Pfeiffer	D12/192
D528,485 S *	9/2006	Montijo et al.	D12/192
D529,948 S *	10/2006	Jimba et al.	D18/43

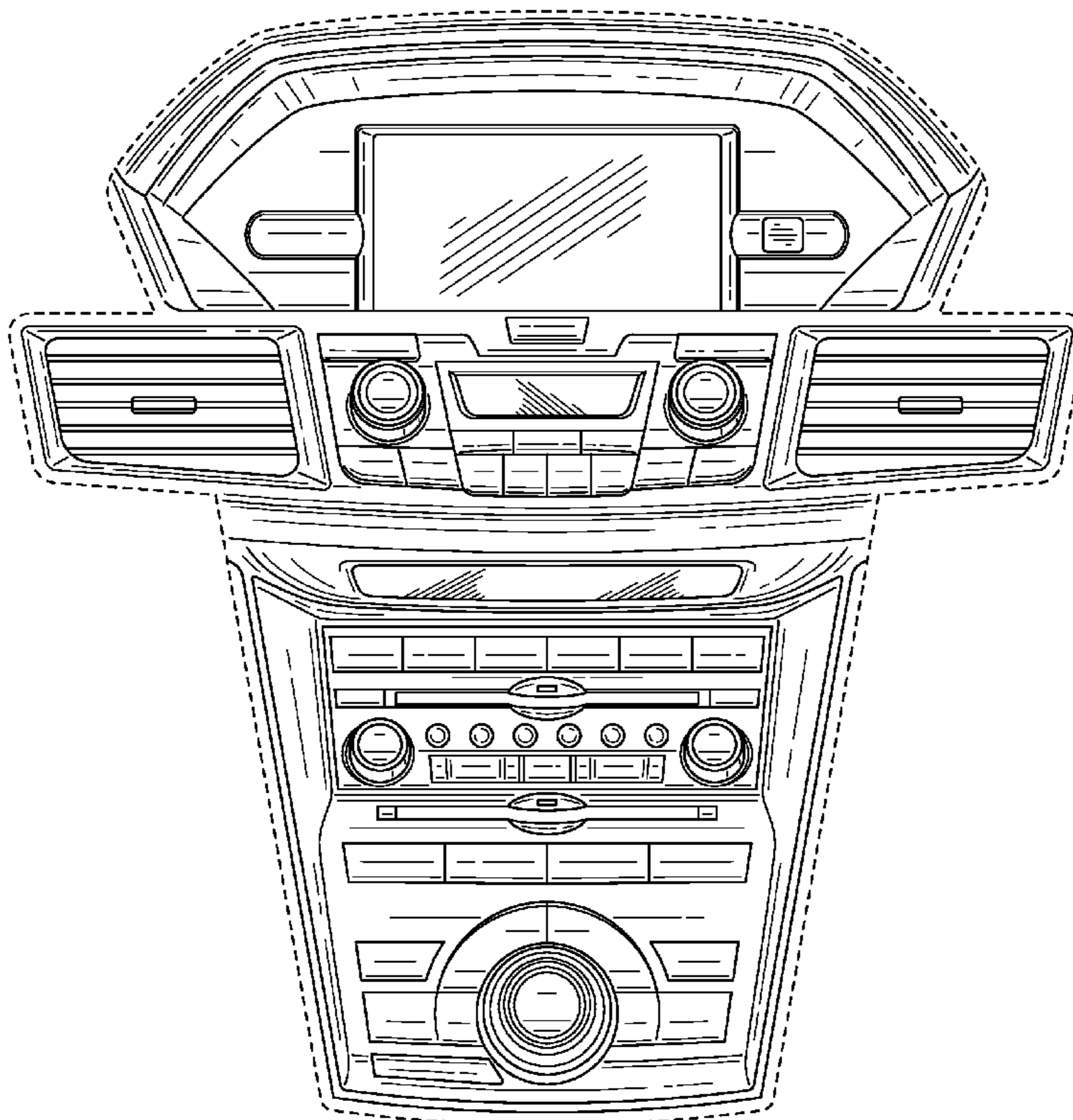

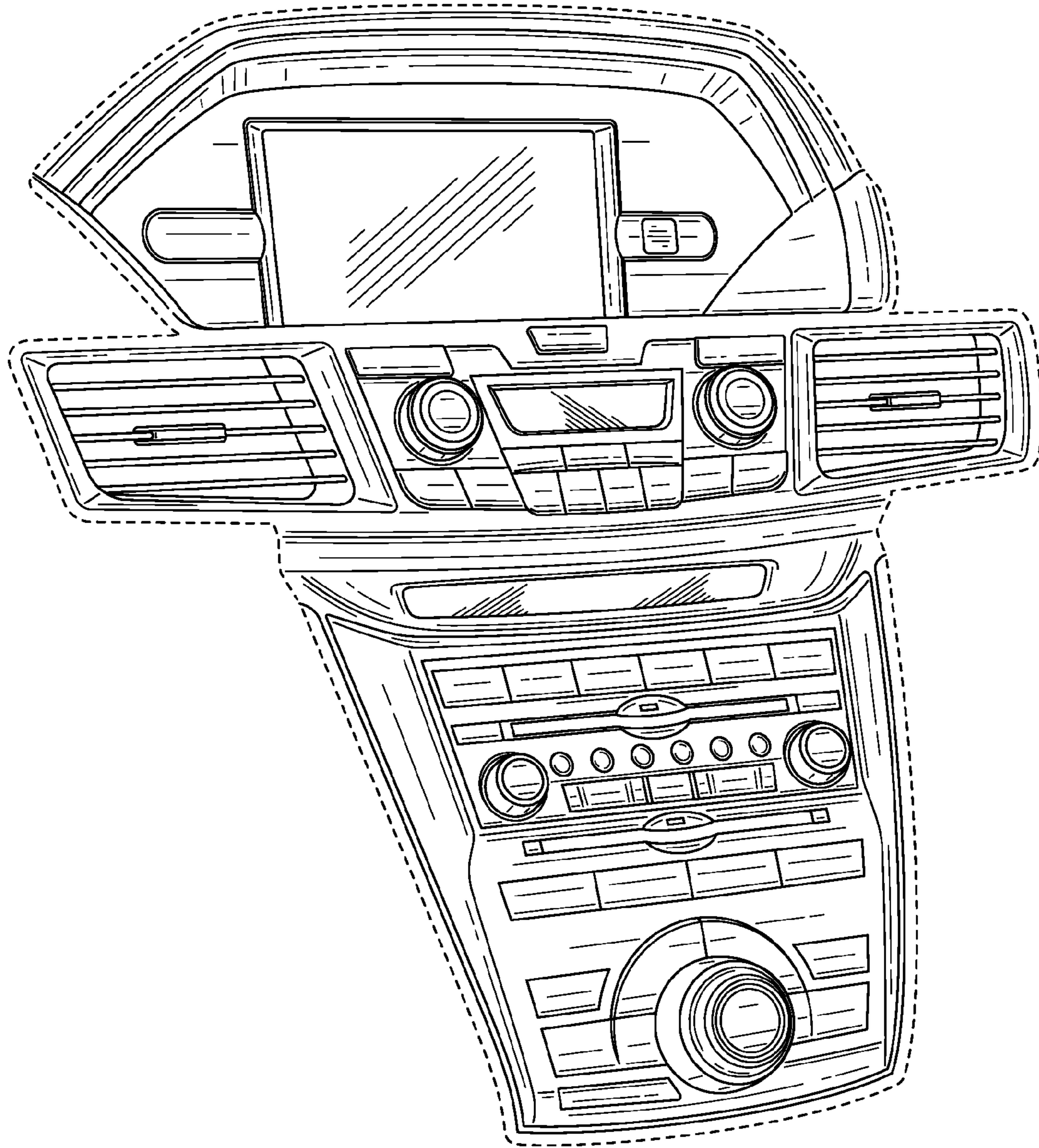

FIG. 1

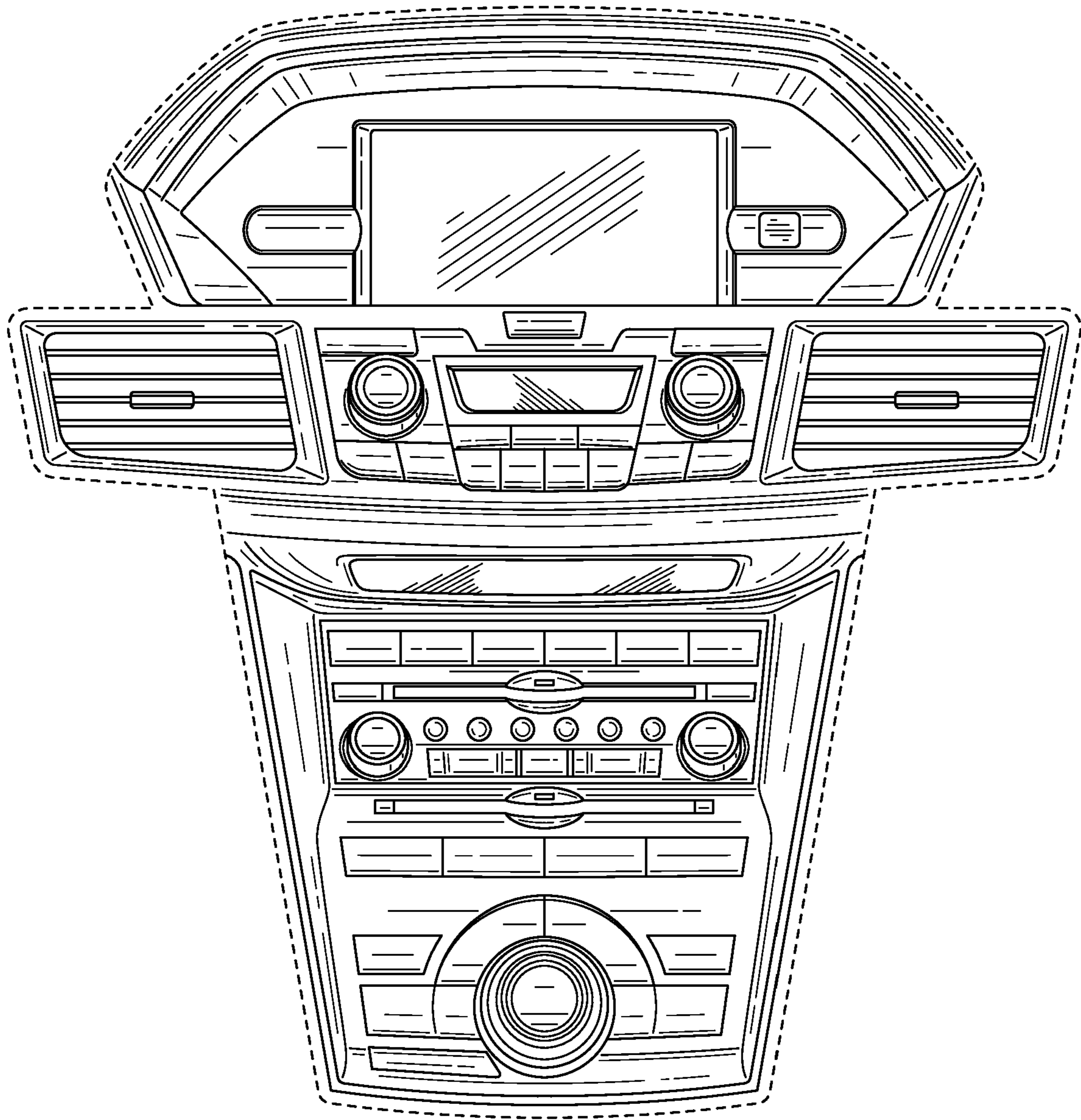

FIG. 2