



US00D632344S

(12) **United States Design Patent**
Hong

(10) **Patent No.:** **US D632,344 S**

(45) **Date of Patent:** **** Feb. 8, 2011**

(54) **SPORTSTER CAR WITH CANOPY AND PUSH BAR**

7,832,757 B2 * 11/2010 McCabe 280/650

* cited by examiner

(76) Inventor: **Jae Hyun Hong**, 16851 Knott Ave., La Mirada, CA (US) 90638

Primary Examiner—Ian Simmons

Assistant Examiner—Charles D Hanson

(74) *Attorney, Agent, or Firm*—John K. Park; Park Law Firm

(**) Term: **14 Years**

(21) Appl. No.: **29/365,546**

(57) **CLAIM**

(22) Filed: **Jul. 9, 2010**

The ornamental design for a sportster car with canopy and push bar, as shown and described.

(51) **LOC (9) Cl.** **21-01**

DESCRIPTION

(52) **U.S. Cl.** **D21/433; D12/129**

(58) **Field of Classification Search** D12/128–133;
D6/360, 367; 280/62, 647–650, 29, 200,
280/47.38, 250.1, 259, 642, 658; 297/DIG. 4;
296/65.03, 65.04; 224/409; D21/425, 426;
D34/17, 18

FIG. 1 is a perspective view of a sportster car with canopy and push bar showing my new design;

FIG. 2 is a front plan view thereof;

FIG. 3 is a rear plan view thereof;

FIG. 4 is a side plan view thereof;

FIG. 5 is another side plan view thereof;

FIG. 6 is a top plan view thereof; and

FIG. 7 is another perspective rear view thereof with a steering wheel in place;

FIG. 8 is the perspective rear view of FIG. 7 with the steering wheel removed;

FIG. 9 is a bottom plan view thereof with a push bar stored in a bottom groove; and,

FIG. 10 is the bottom plan view of FIG. 9 with a push bar removed from the bottom groove.

See application file for complete search history.

The broken line showing of environment is for illustrative purposes only and forms no part of the claimed design.

(56) **References Cited**

U.S. PATENT DOCUMENTS

D305,011 S *	12/1989	Pipon	D12/129
D332,592 S *	1/1993	O'Dea et al.	D12/129
D364,132 S *	11/1995	Badon et al.	D12/129
D388,027 S *	12/1997	Polak et al.	D12/129
D388,367 S *	12/1997	Polak et al.	D12/129
D388,473 S *	12/1997	Pasin et al.	D21/425
D432,185 S *	10/2000	Hulst	D21/433
D451,849 S *	12/2001	Noshi	D12/131
6,446,981 B1 *	9/2002	Wise et al.	280/7.17
6,497,424 B2 *	12/2002	Gartner et al.	280/47.4
D547,393 S *	7/2007	Johnson et al.	D21/433
D564,040 S *	3/2008	Kurth et al.	D21/433

1 Claim, 10 Drawing Sheets

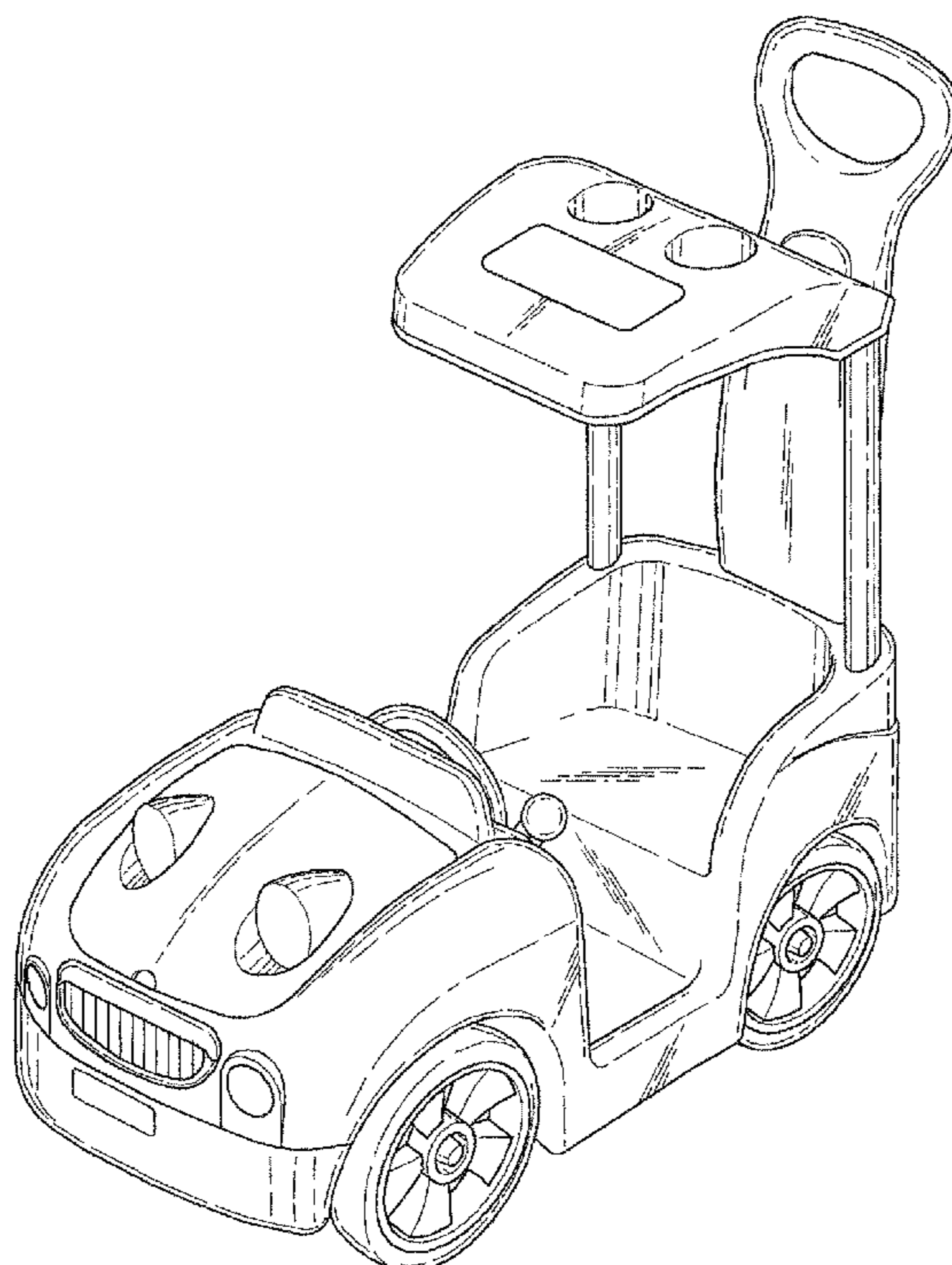

FIG. 1

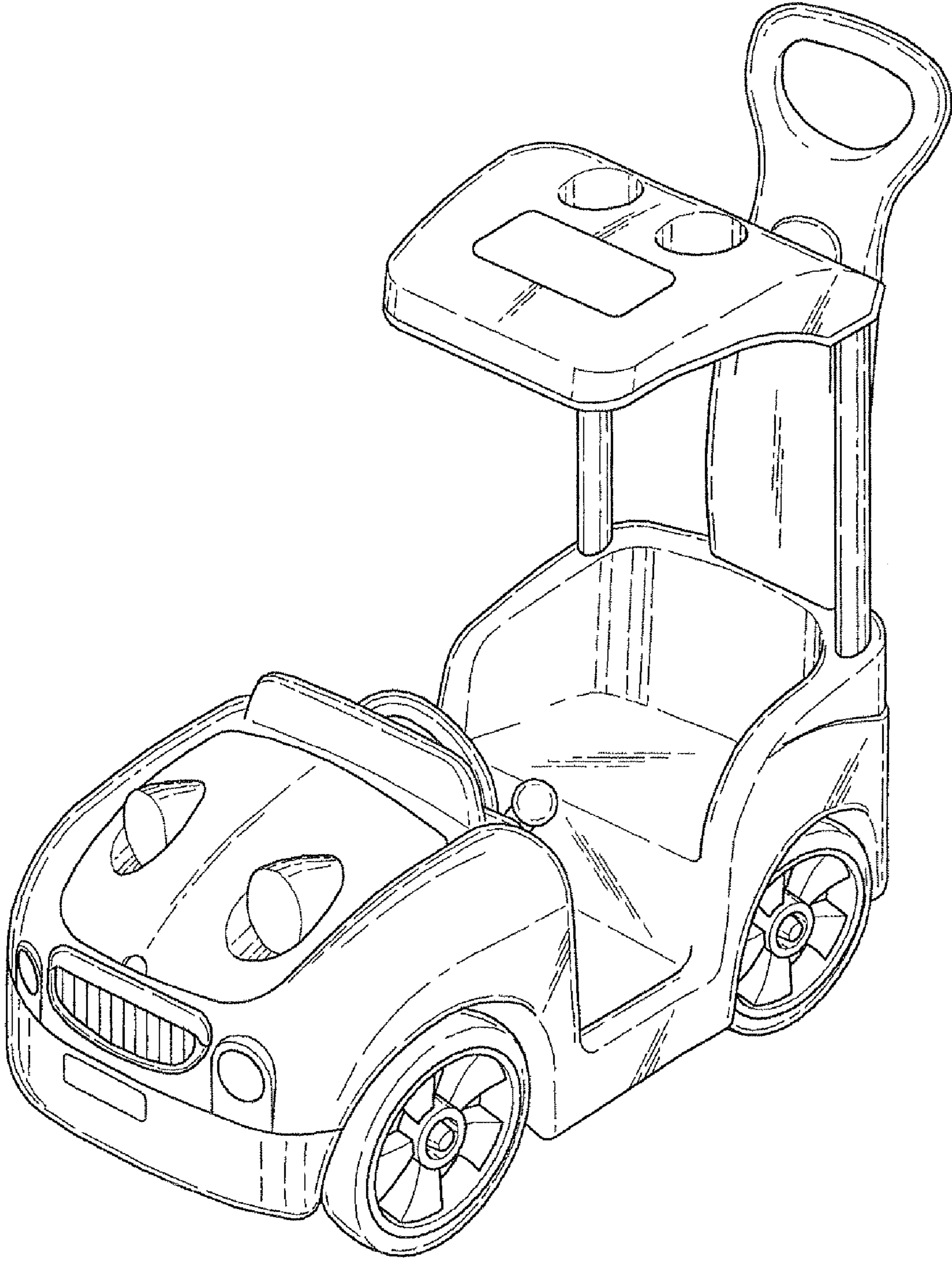

FIG. 2

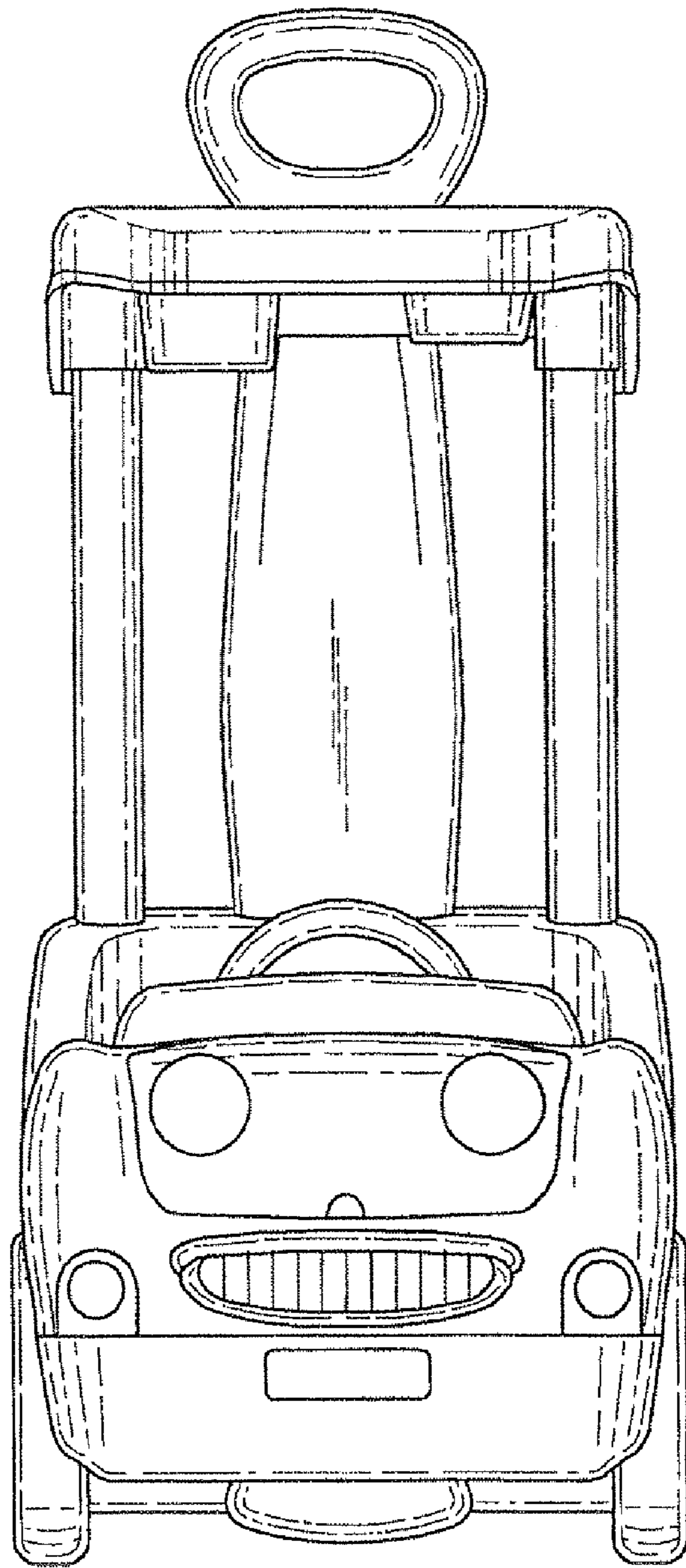

FIG. 3

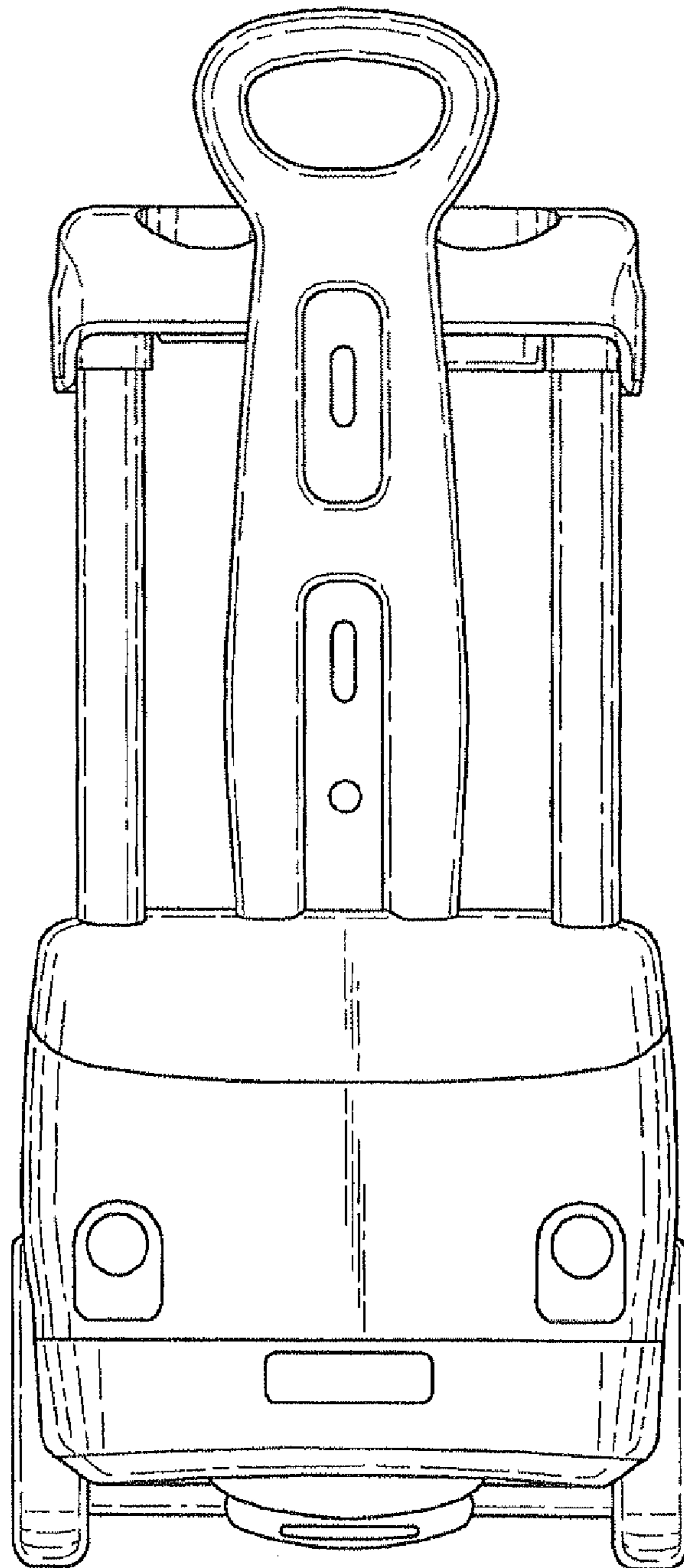

FIG. 4

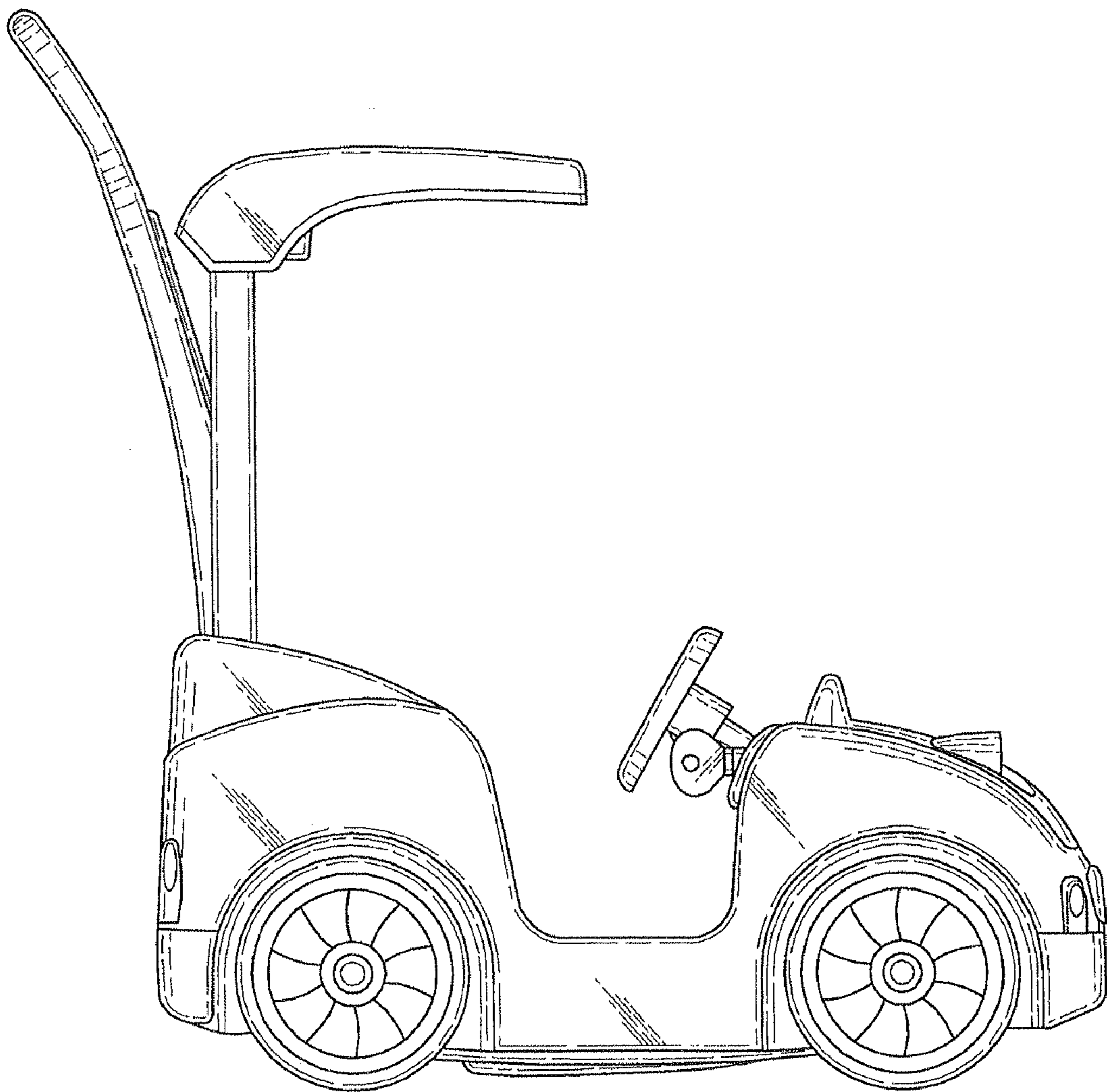

FIG. 5

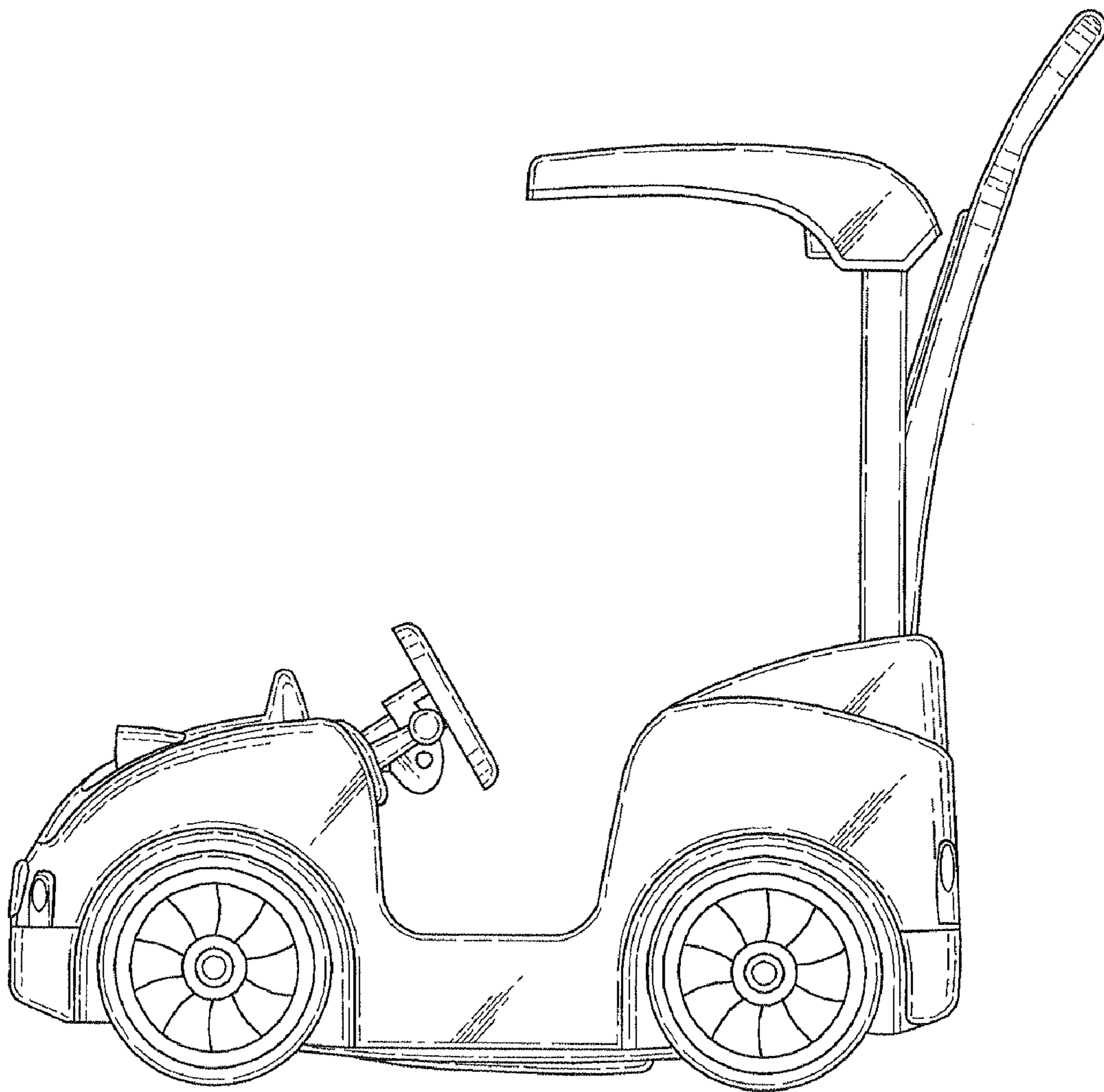

FIG. 6

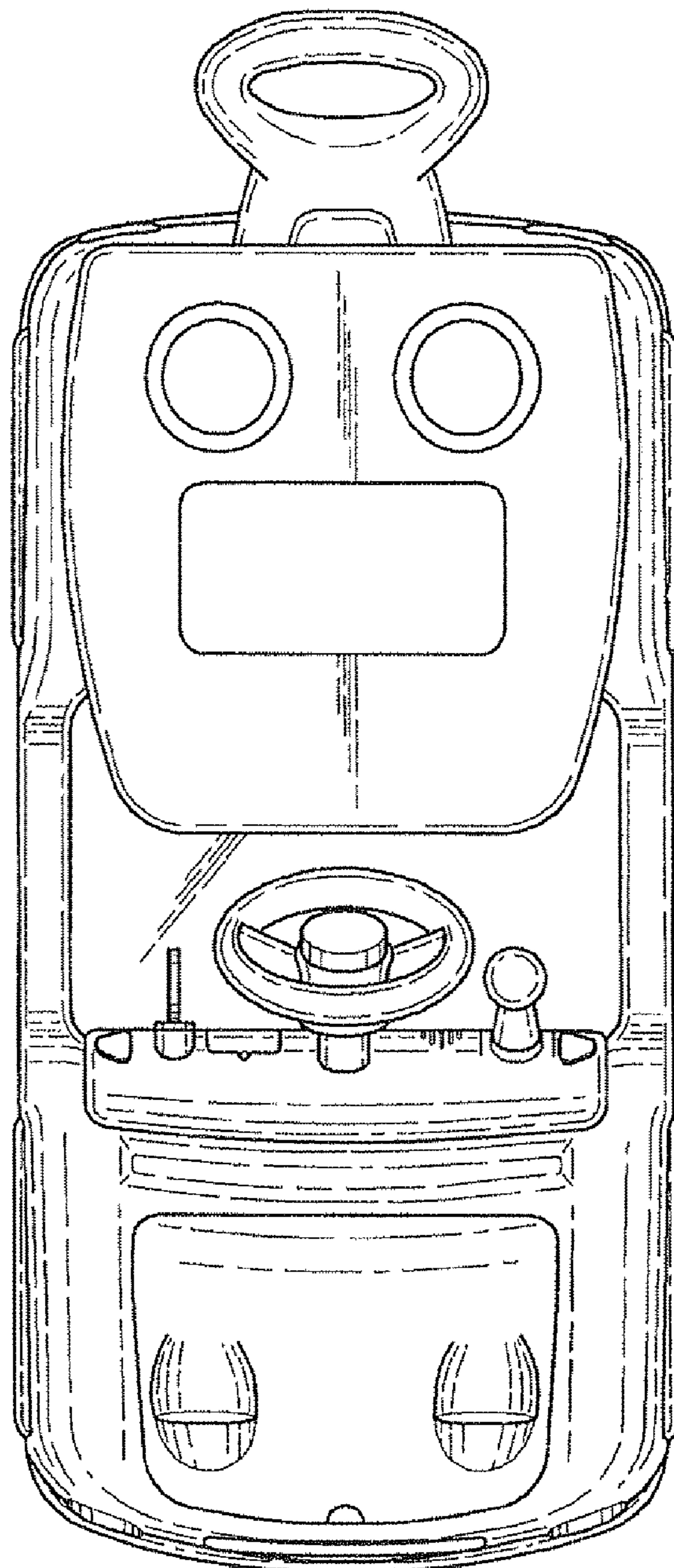

FIG. 7

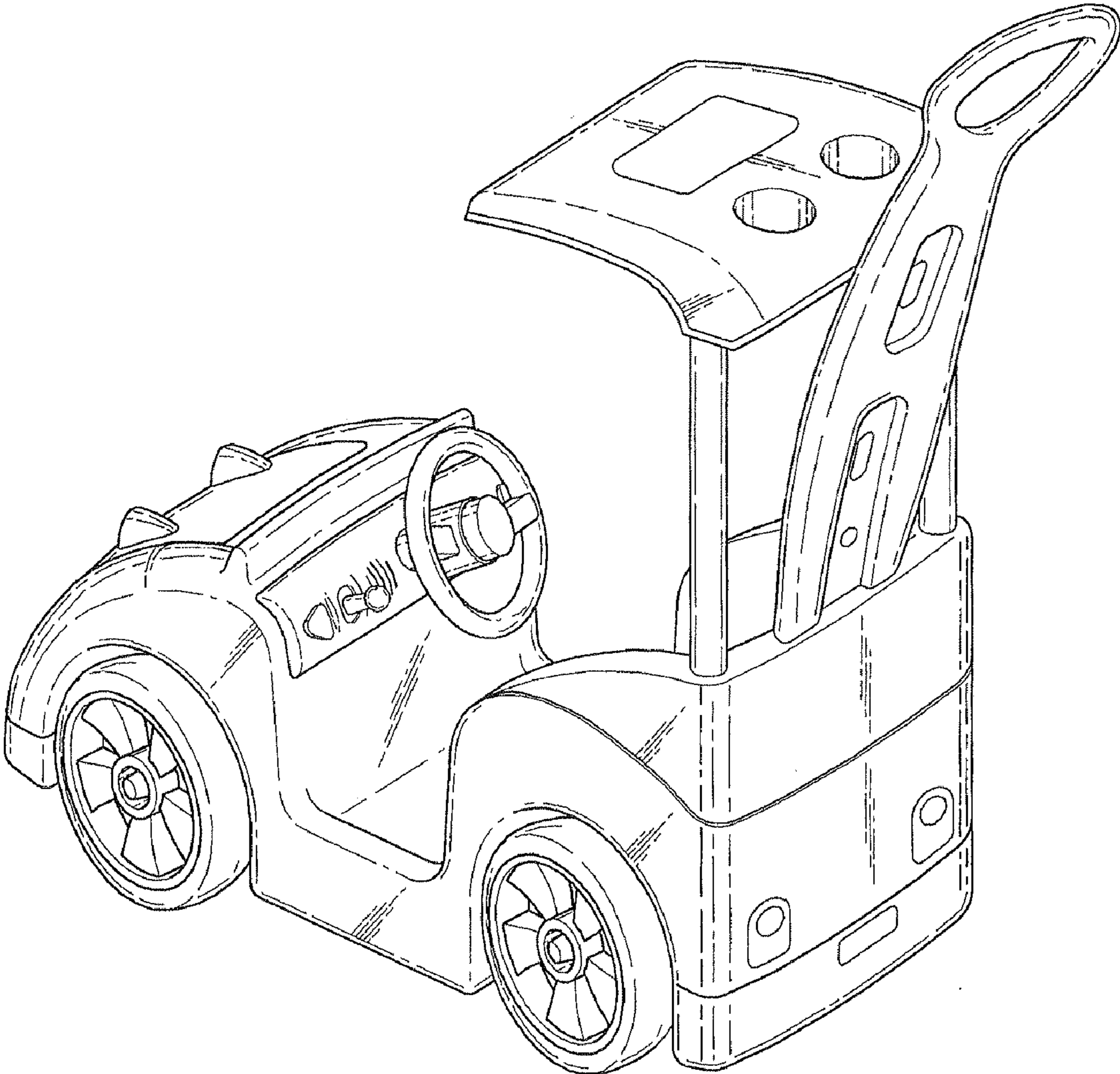

FIG. 8

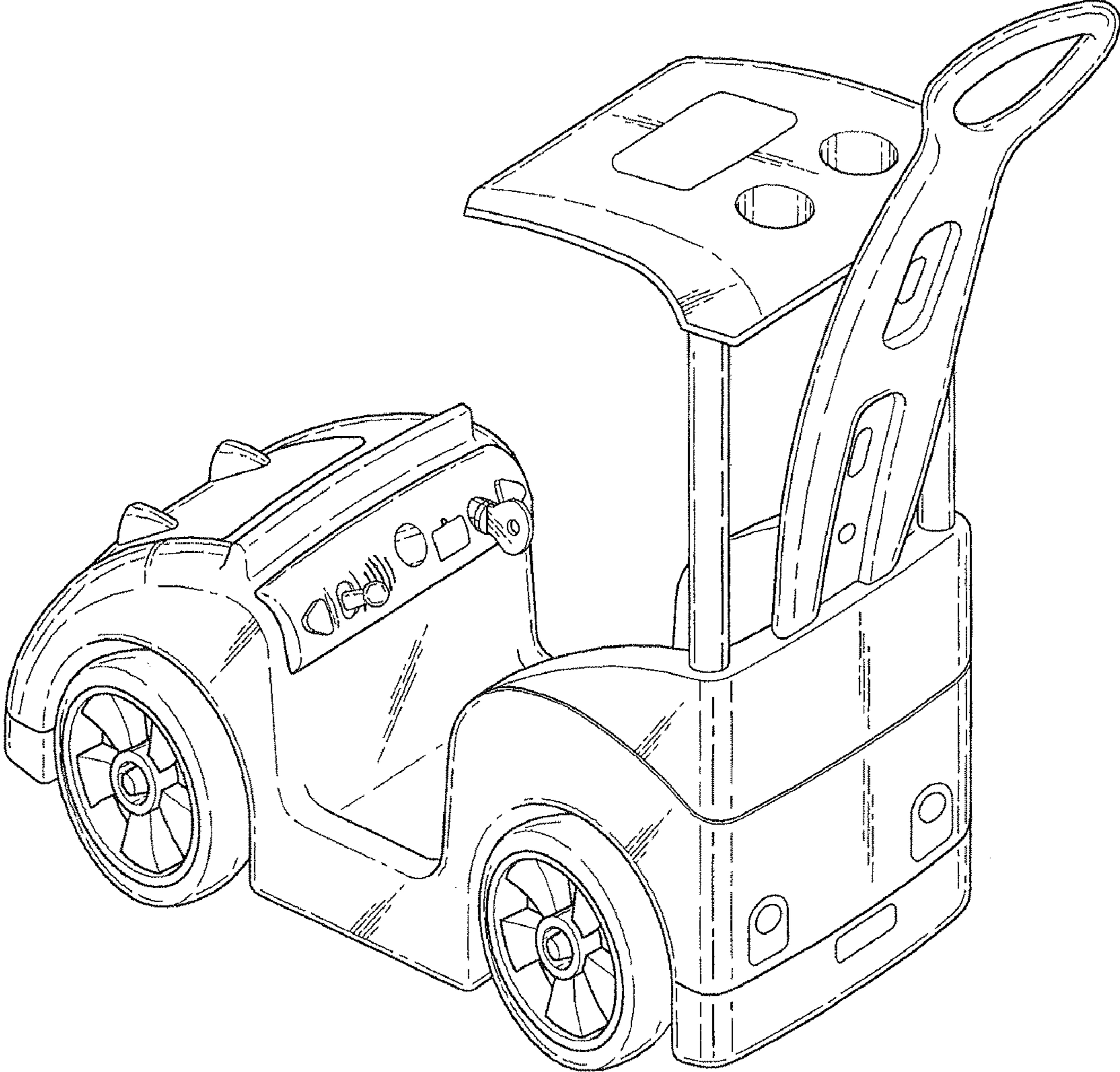

FIG. 9

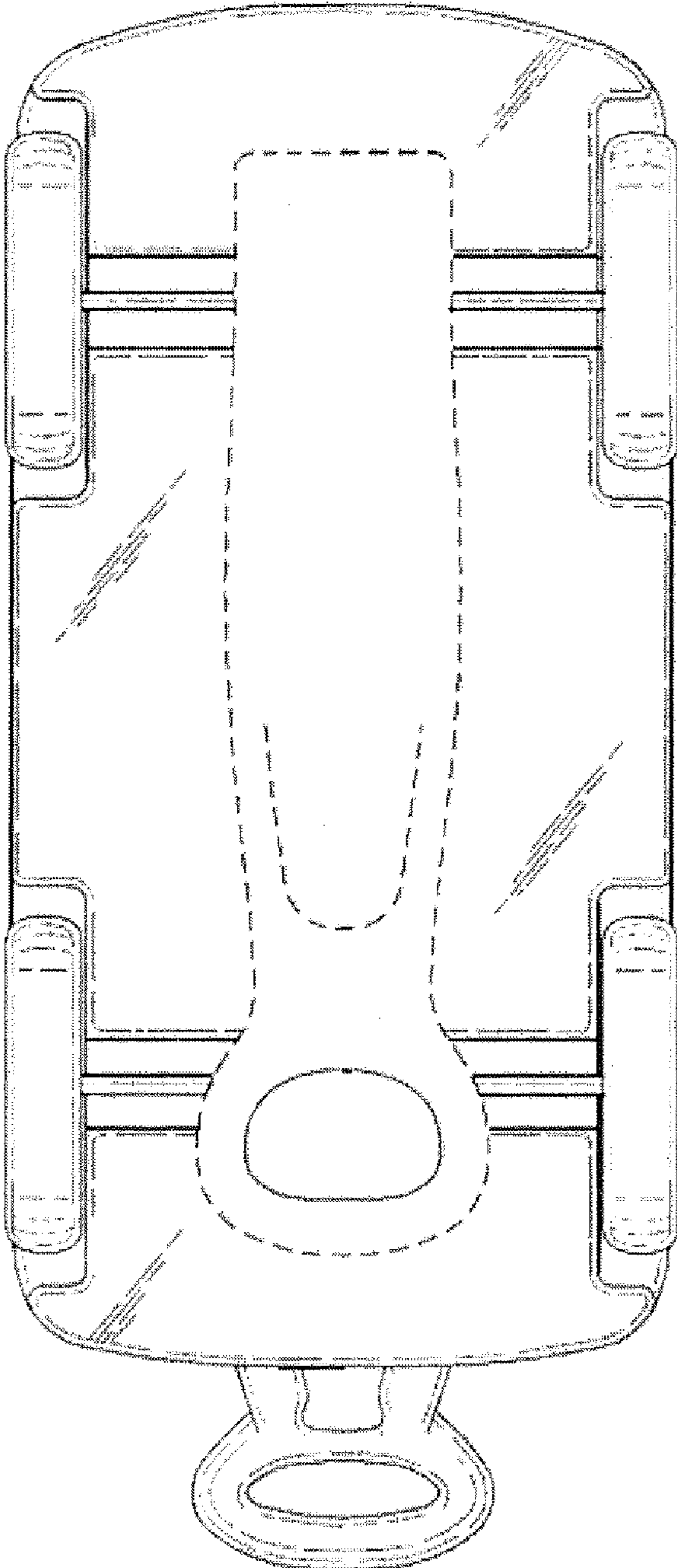

FIG. 10

