



US00D632228S

(12) **United States Design Patent**
Marin

(10) **Patent No.:** **US D632,228 S**
(45) **Date of Patent:** **** Feb. 8, 2011**

(54) **BIKE RACK**

7,784,622 B2 * 8/2010 Bernard 211/20

(76) Inventor: **Radovan Marin**, info@auto-mart.hr,
Zagreb (HR) 10000

* cited by examiner

(**) Term: **14 Years**

Primary Examiner—Philip S Hyder

Assistant Examiner—Linda G. Brooks

(21) Appl. No.: **29/362,774**

(74) *Attorney, Agent, or Firm*—Eric Hanscom; Todd Langford

(22) Filed: **May 29, 2010**

(57) **CLAIM**

(51) **LOC (9) Cl.** **12-11**

The ornamental design for a bike rack, as shown and described.

(52) **U.S. Cl.** **D12/115**

(58) **Field of Classification Search** D12/115,
D12/120, 406–408; 211/5, 17–22, 8, 182,
211/85.8; 248/514, 515, 518–520, 528, 529,
248/149, 150, 419, 420, 176.3; 224/924;
52/64, 122.1; 411/537, 538; 414/592, 598,
414/599

See application file for complete search history.

DESCRIPTION

FIG. 1 is a front view of a bike rack showing my new design as it would appear with a bicycle attached;

FIG. 2 is a back view thereof;

FIG. 3 is a right-side view thereof;

FIG. 4 is a front view thereof;

FIG. 5 is a top view thereof;

FIG. 6 is a bottom view thereof;

FIG. 7 is a left-side view thereof; and,

FIG. 8 is a front view showing the bicycle-holding section fully extended, and also shown broken away at the bottom left edge for convenience of illustration.

The dashed lines used in the figures are environmental and form no part of the claimed design.

(56) **References Cited**

U.S. PATENT DOCUMENTS

4,316,544	A *	2/1982	Goldstein	211/5
4,352,432	A *	10/1982	Smith	211/19
D288,995	S *	3/1987	Cooper	D21/664
D302,803	S *	8/1989	Villanueva	D12/115
5,082,120	A *	1/1992	Vega	211/20
5,833,074	A *	11/1998	Phillips	211/21
5,941,397	A *	8/1999	Buchanan et al.	211/19
7,481,027	B2 *	1/2009	Blume	52/79.1
D604,207	S *	11/2009	Selzer et al.	D12/115

1 Claim, 7 Drawing Sheets

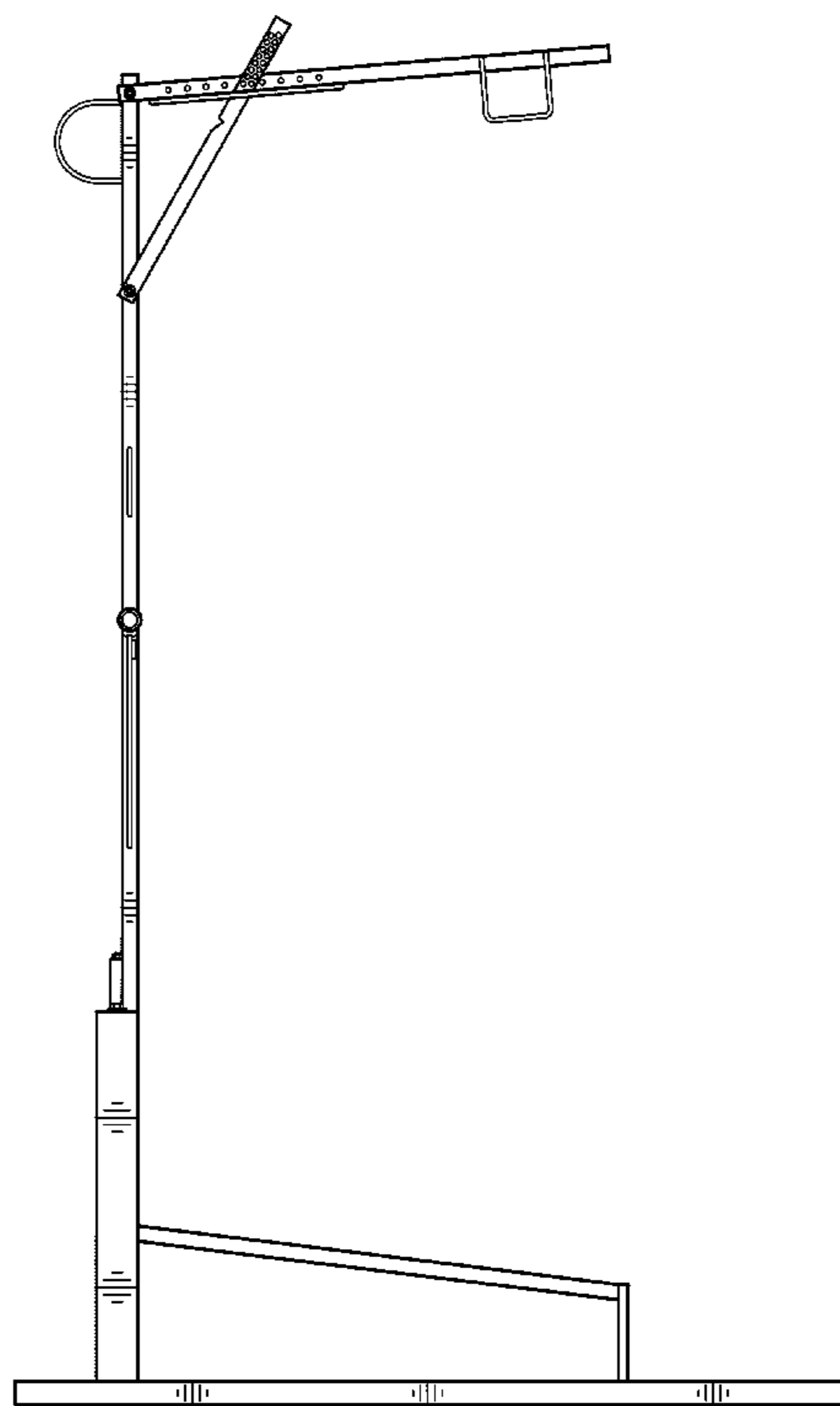

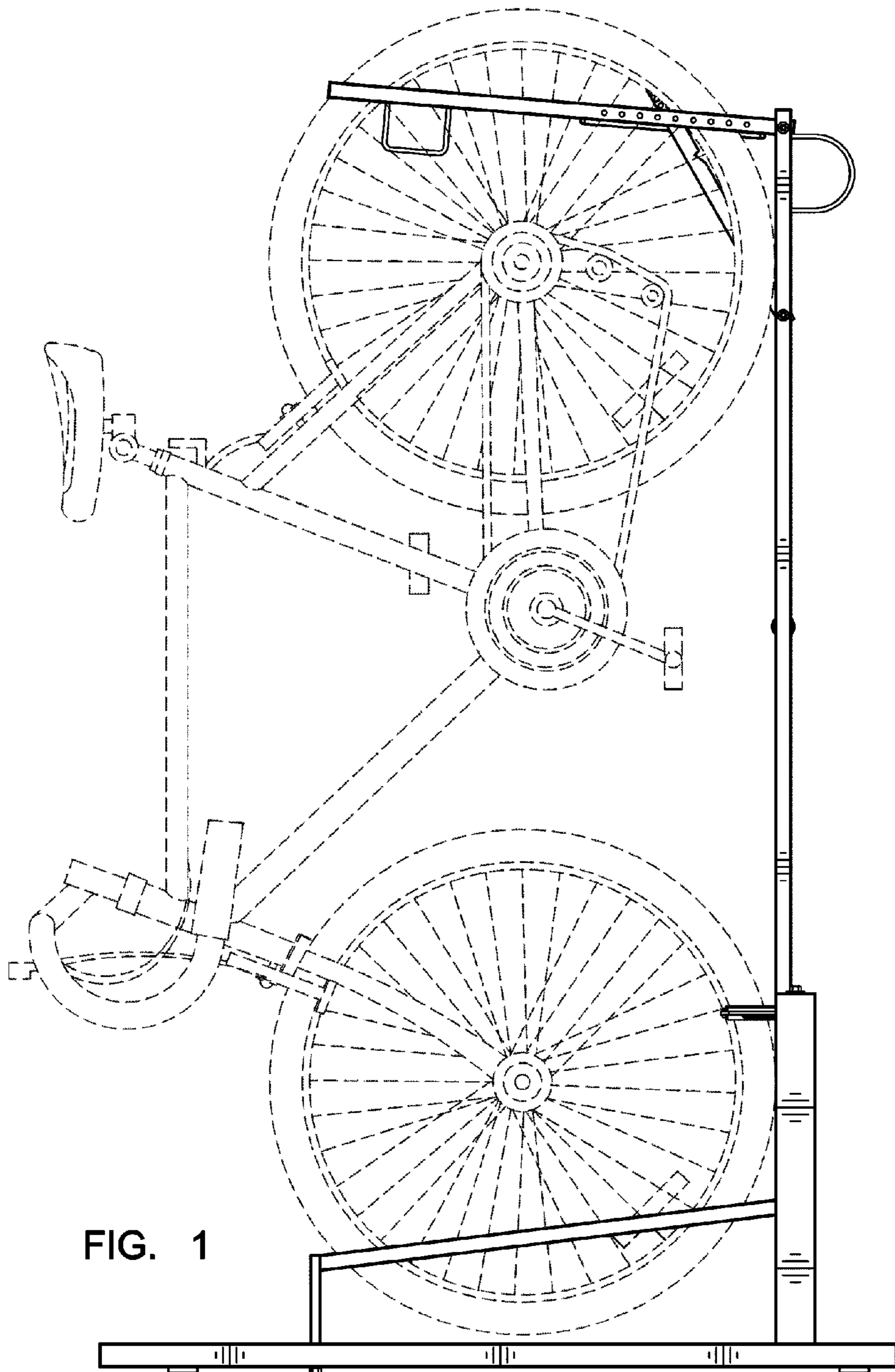

FIG. 1

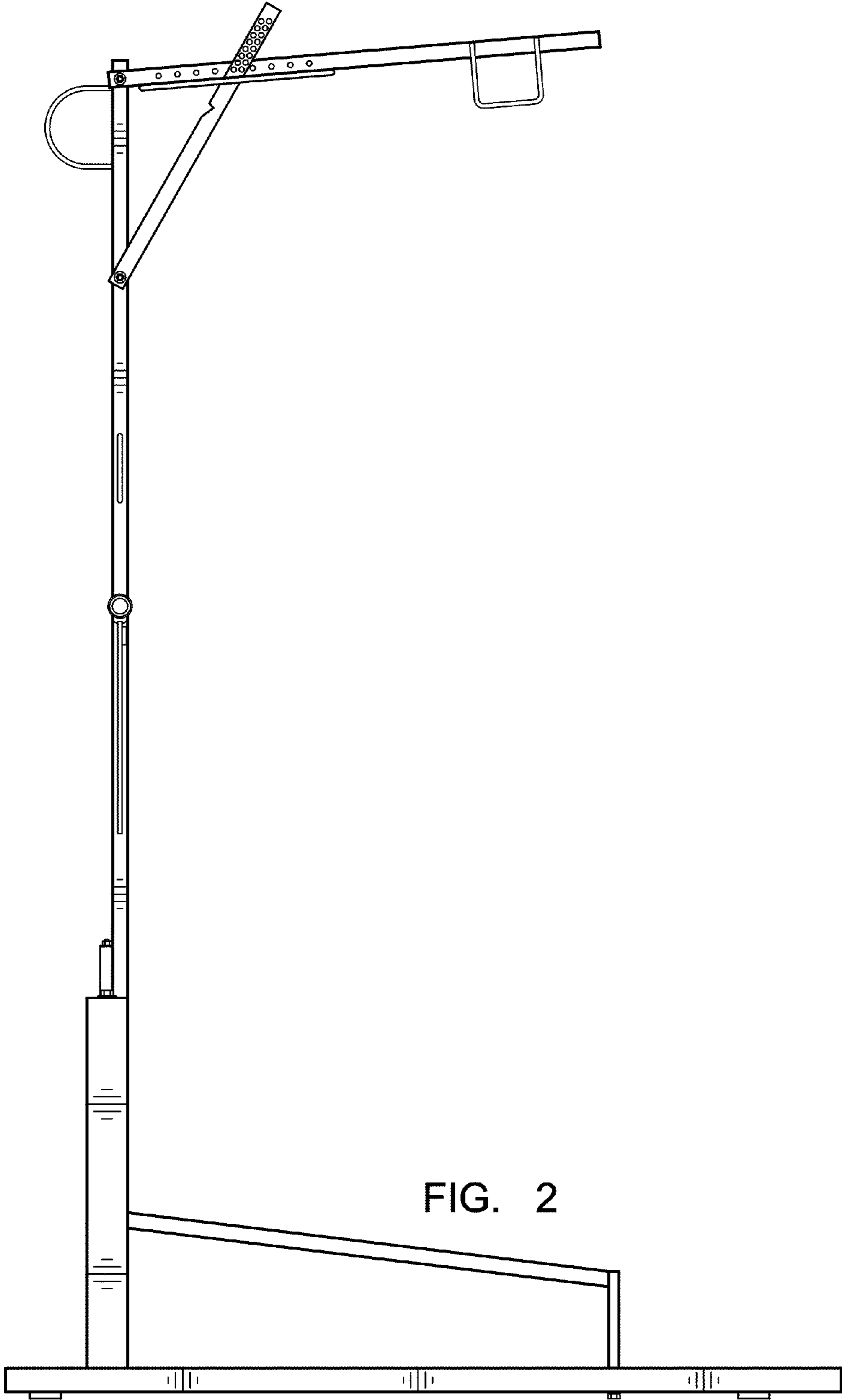
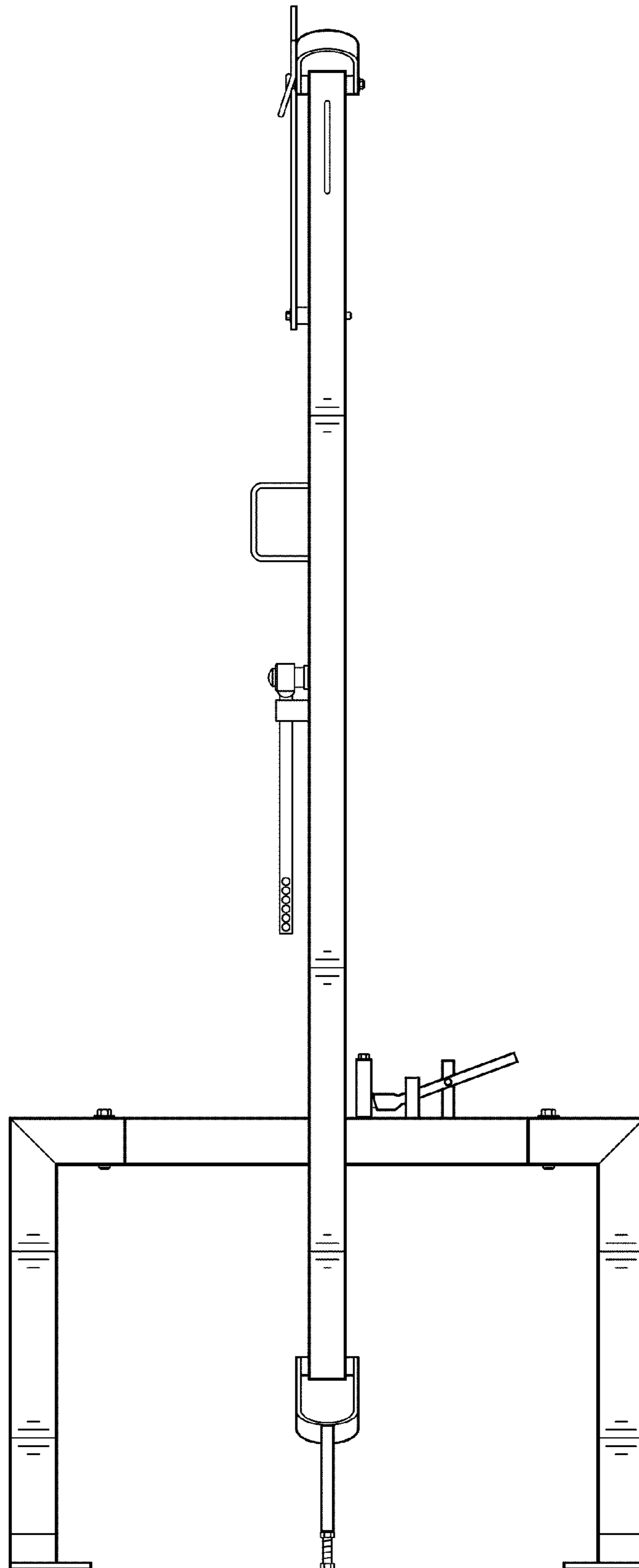
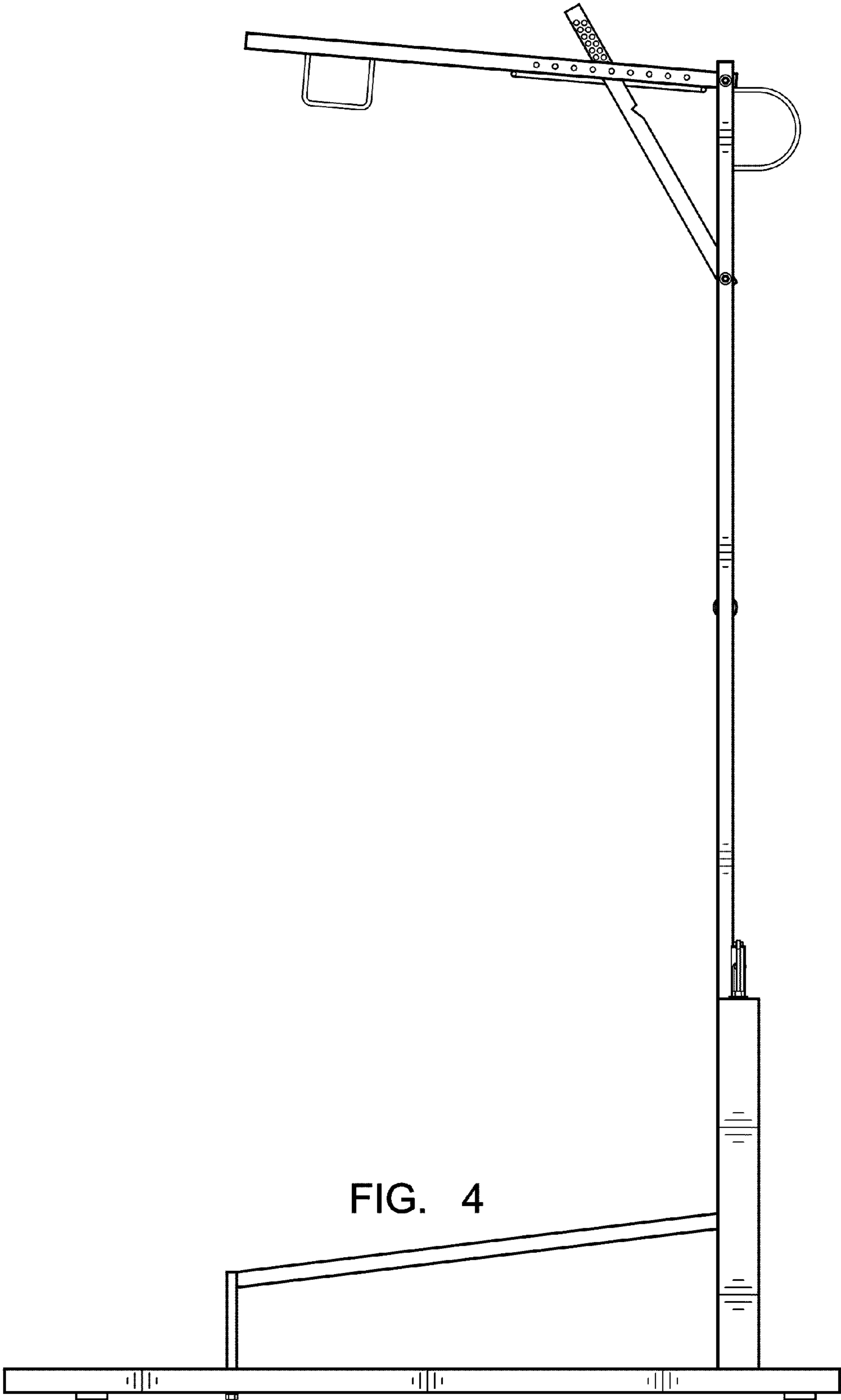

FIG. 2

FIG. 3





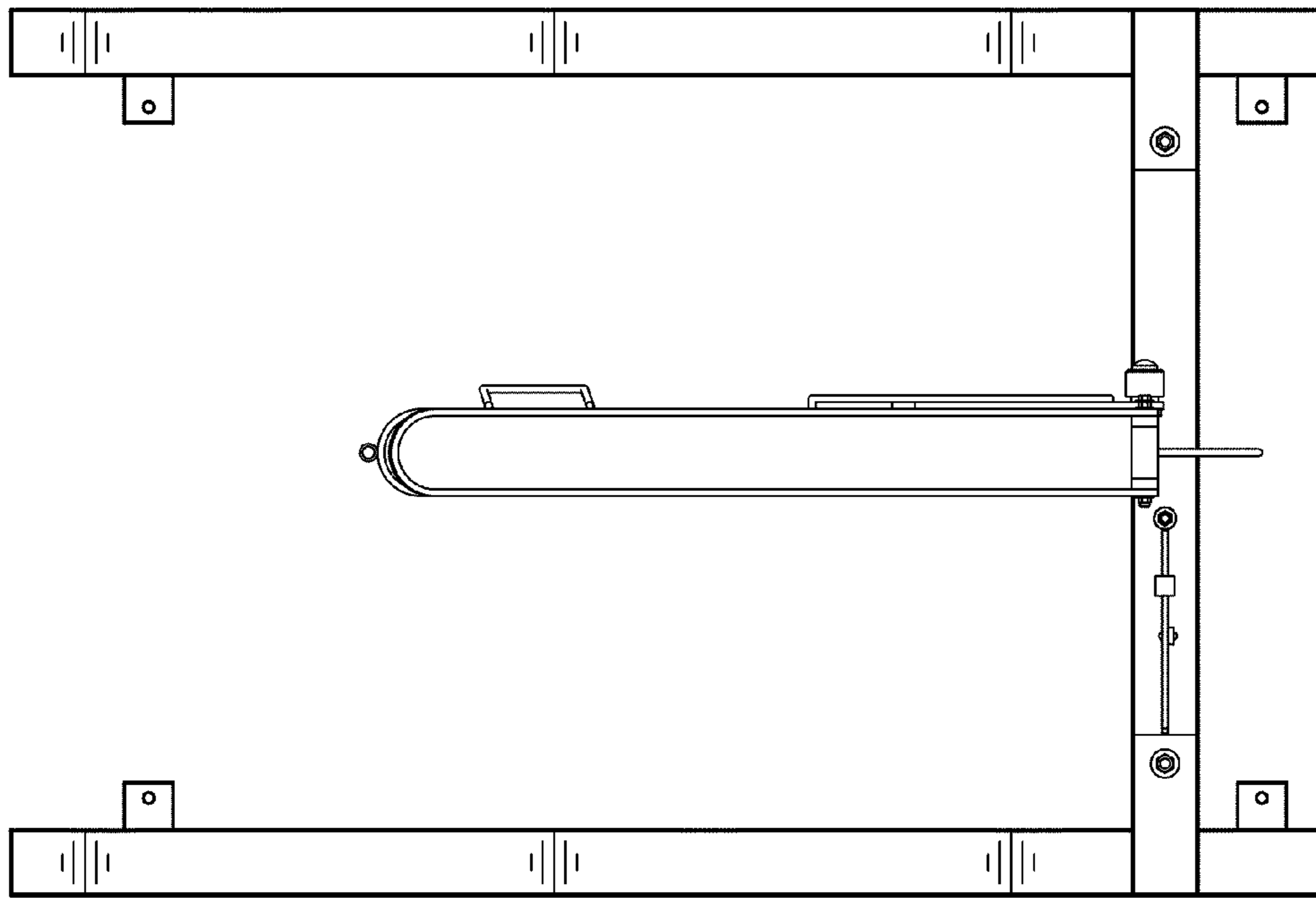

FIG. 5

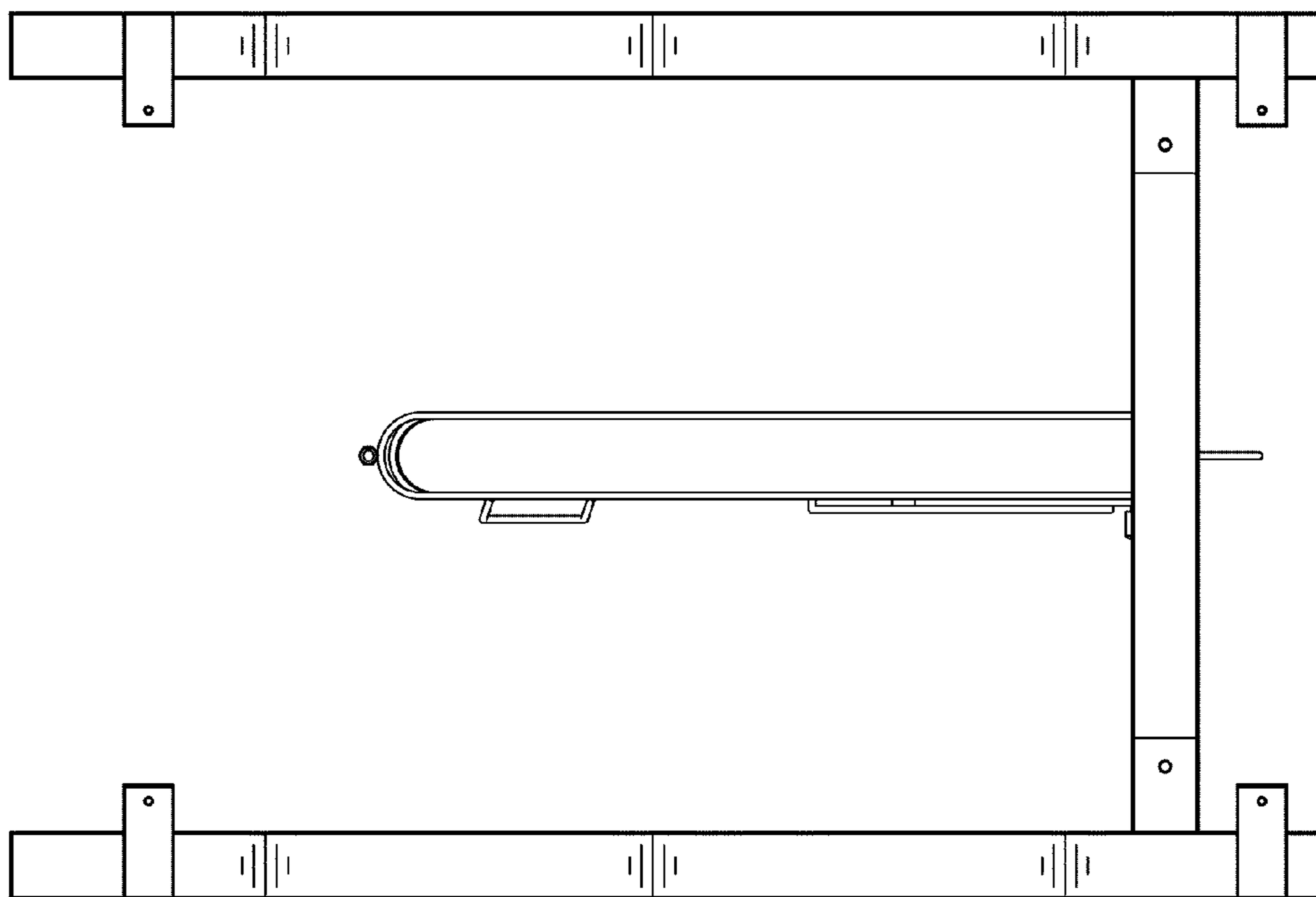

FIG. 6

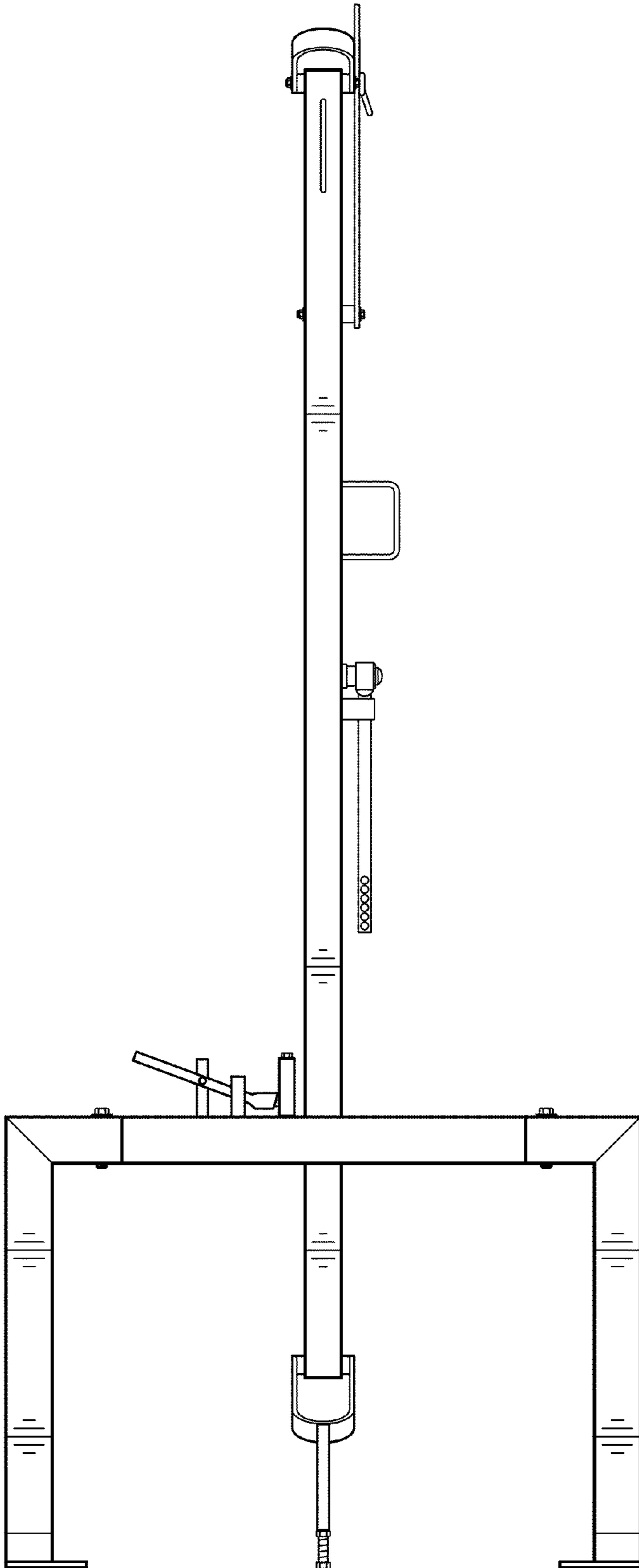

FIG. 7

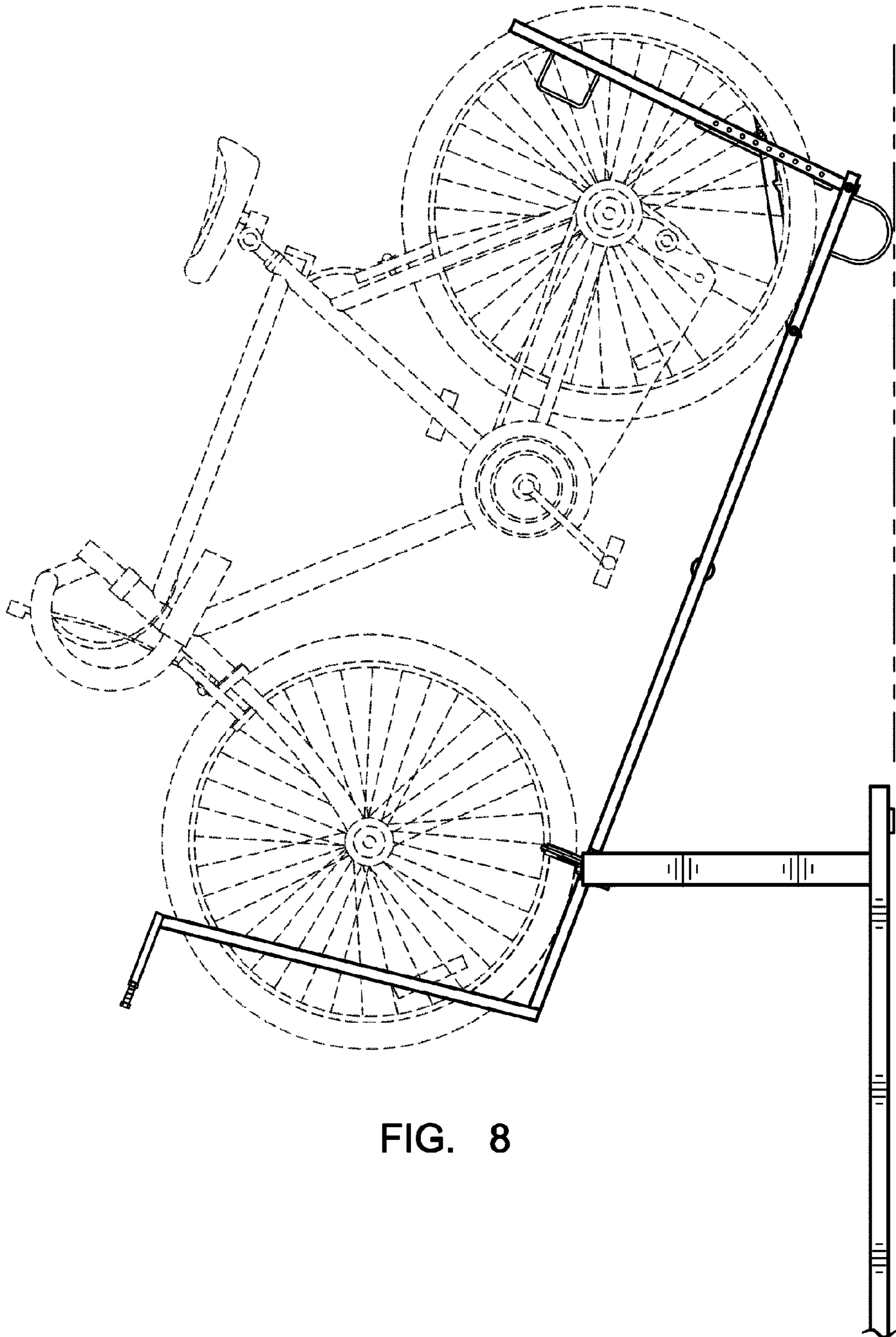

FIG. 8