



US00D632224S

(12) **United States Design Patent**
Peltola et al.

(10) **Patent No.:** **US D632,224 S**
(45) **Date of Patent:** **** Feb. 8, 2011**

(54) **TRUCK BODY**

D320,583 S 10/1991 Simons
D366,638 S 1/1996 Tucker
D382,844 S 8/1997 Norwood
D395,848 S 7/1998 Meryman

(75) Inventors: **Wallace A Peltola**, Sammamish, WA (US); **Jonathan Duncan**, Seattle, WA (US); **Steven H Hovind**, Bellevue, WA (US); **Charles Baer**, Bellevue, WA (US); **Gerald J Angelo**, Bellevue, WA (US); **Alec C Wong**, Bellevue, WA (US); **Steven L Baker**, Duvall, WA (US); **Erik D Hjorten**, Everett, WA (US); **Casey W Keil**, Renton, WA (US); **Adam G Salnick**, Seattle, WA (US); **James E Schatzer**, Maple Valley, WA (US); **Jonathan F Wilkens**, Kirkland, WA (US); **Greg W Bonsen**, Bellevue, WA (US); **Jameson L Longman**, Bellevue, WA (US); **Mark Dyal**, Renton, WA (US)

(Continued)

OTHER PUBLICATIONS

“T660,” Kenworth Truck Company, Kirkland, Washington, 2007, 36-page brochure.

(Continued)

Primary Examiner—Melody N Brown
(74) *Attorney, Agent, or Firm*—Christensen O’Connor Johnson Kindness PLLC

(73) Assignee: **PACCAR Inc**, Bellevue, WA (US)

(**) Term: **14 Years**

(57) **CLAIM**

(21) Appl. No.: **29/360,606**

The ornamental design for a truck body, as shown and described.

(22) Filed: **Apr. 28, 2010**

(51) **LOC (9) Cl.** **12-16**

DESCRIPTION

(52) **U.S. Cl.** **D12/96; D12/173**

(58) **Field of Classification Search** D12/96,
D12/97, 98, 12, 90–92, 173; 296/180.1–180.3,
296/181.1–185, 186, 186.1; 180/89.12, 89.1,
180/242, 449

FIG. 1 is a front right perspective view of a truck body showing our new design;

FIG. 2 is a front elevational view of the truck body of FIG. 1;

FIG. 3 is a top plan view of the truck body of FIG. 1; and,

FIG. 4 is a right side elevational view of the truck body of FIG. 1, the left side elevational view being mirror symmetrical to FIG. 4.

See application file for complete search history.

The broken-line shows a wheel, chassis fairings, a portion of a truck cab, a portion of a truck roof, fender marker light and emblem seat is for the purpose of illustrating environmental structure and forms no part of the claimed design.

(56) **References Cited**

U.S. PATENT DOCUMENTS

D291,982 S 9/1987 Simons
D307,731 S 5/1990 Kerney
D312,609 S 12/1990 Preslik
D312,805 S 12/1990 Marlowe
D312,810 S 12/1990 Preslik
D313,954 S 1/1991 Fingerle
D319,036 S 8/1991 Fingerle

1 Claim, 4 Drawing Sheets

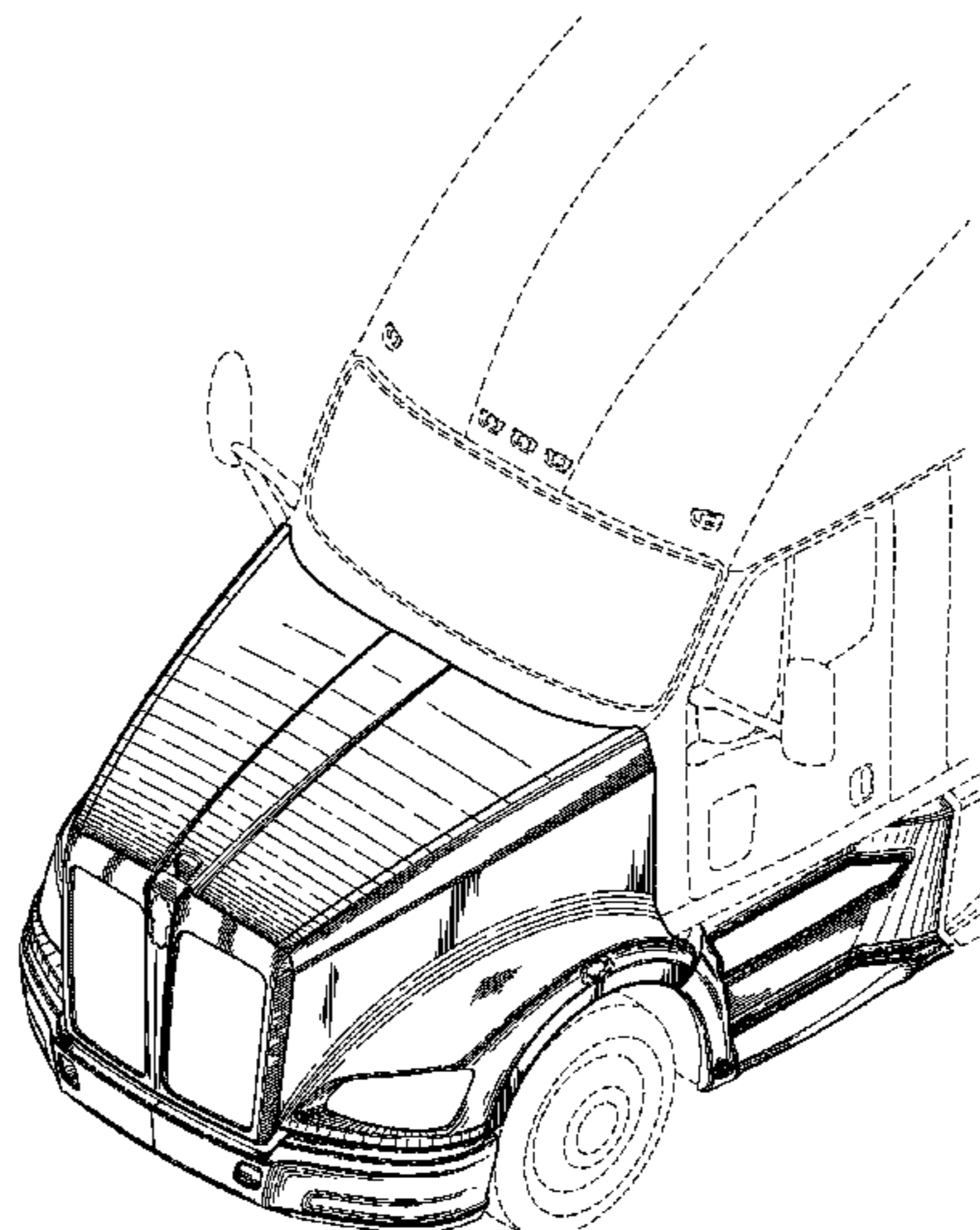

U.S. PATENT DOCUMENTS

D395,860 S 7/1998 Meryman
 D403,636 S 1/1999 Meryman
 D411,140 S 6/1999 Meryman
 D411,494 S 6/1999 Meryman
 D412,689 S 8/1999 Onopa
 D420,622 S 2/2000 Hellhake
 D422,251 S 4/2000 Bader
 D422,957 S 4/2000 Damon
 D423,429 S 4/2000 Hickman
 D423,990 S 5/2000 Meryman
 D429,669 S 8/2000 Cook
 D433,365 S 11/2000 Beigel
 D433,967 S 11/2000 Delashaw
 D433,981 S 11/2000 Davis
 D434,348 S 11/2000 Delashaw
 D435,816 S 1/2001 Delashaw
 D436,563 S 1/2001 Delashaw
 D437,258 S 2/2001 Meryman
 D442,132 S 5/2001 Weidhase
 D450,277 S 11/2001 Onopa
 D460,023 S 7/2002 Beigel
 D465,749 S 11/2002 Beigel
 D476,929 S 7/2003 Dozier
 D478,027 S 8/2003 Chiang
 D478,028 S 8/2003 Chiang
 D482,302 S 11/2003 Dozier
 D482,993 S 12/2003 Conway
 D484,077 S 12/2003 Conway
 D488,112 S 4/2004 Satou
 D491,858 S 6/2004 Velazco
 D492,627 S 7/2004 Metros
 D492,628 S 7/2004 Bond
 D492,801 S 7/2004 Metros
 D494,898 S 8/2004 Metros
 D497,581 S 10/2004 Conway
 D498,716 S 11/2004 Maeda
 D502,901 S 3/2005 Delashaw
 D504,642 S 5/2005 Perfetti
 D518,424 S 4/2006 Clark
 D519,067 S 4/2006 Steere
 D519,068 S 4/2006 Clark
 D519,069 S 4/2006 Clark
 D522,945 S 6/2006 Beigel
 D530,653 S 10/2006 Angelo
 D531,940 S 11/2006 McCuller
 D531,948 S 11/2006 Angelo
 D532,350 S 11/2006 Angelo
 D532,731 S 11/2006 Angelo
 D539,704 S 4/2007 Angelo
 D540,722 S 4/2007 Angelo
 D540,725 S 4/2007 Gunter
 D540,727 S 4/2007 Elliott
 D545,250 S 6/2007 Angelo
 D545,251 S 6/2007 Angelo
 D545,735 S 7/2007 Angelo
 D560,575 S 1/2008 Simons
 D561,647 S 2/2008 Simons
 D563,849 S 3/2008 Medina
 D563,850 S 3/2008 Rosen
 D563,851 S 3/2008 Rosen
 D563,852 S 3/2008 Rosen
 D563,853 S 3/2008 Rosen
 D571,696 S 6/2008 Rosen
 D578,453 S 10/2008 Raghavendran et al.
 D588,512 S * 3/2009 Raghavendran et al. D12/173
 D619,941 S * 7/2010 Krauss D12/173
 D621,754 S * 8/2010 Angelo et al. D12/173

D622,188 S * 8/2010 Angelo et al. D12/96

OTHER PUBLICATIONS

“T800,” Kenworth Truck Company, Kirkland, Washington, 1996, 7-page brochure.
 “T800,” Kenworth Truck Company, Kirkland, Washington, 2002, 32-page brochure.
 “T800,” Kenworth Truck Company, Kirkland, Washington, 2003, 32-page brochure.
 “T800,” Kenworth Truck Company, Kirkland, Washington, 2005, 28-page brochure.
 “T800B,” Kenworth Truck Company, Kirkland, Washington, 1993, 8-page brochure.
 “The Working Class,” Peterbilt Motors Company, Newark, California, Sep. 1976, 6 page brochure.
 “The World’s Best,” Kenworth Truck Company, Kirkland, Washington, 1992, 12-page brochure.
 “Unibilt™ Cab Sleeper System,” Peterbilt Motors Company, Denton Texas, Aug. 1994, 6 page brochure.
 “W900,” Kenworth Truck Company, Kirkland, Washington, 1996, 7-page brochure.
 “W900,” Kenworth Truck Company, Kirkland, Washington, 2002, 32-page brochure.
 “W900,” Kenworth Truck Company, Kirkland, Washington, 2005, 28-page brochure.
 “W900L Aero Cab,” Kenworth Truck Company, Kirkland, Washington, 1994, 2-page brochure.
 “AeroCab,” Kenworth Truck Company, Kirkland, Washington, 1993, 6-page brochure.
 “AeroCab,” Kenworth Truck Company, Kirkland, Washington, as early as 1995, 3-page brochure.
 “C500B,” Kenworth Truck Company, Kirkland, Washington, as early as 1990, 4-page brochure.
 “Cabovers,” Peterbilt Motors Company, Newark, California, as early as 2000, 7 page brochure.
 “Class Pays, Construction Trucks,” Peterbilt Motors Company, Denton, Texas, Nov. 2003, 16-page brochure.
 “Class Pays, Ergonomic Dash,” Peterbilt Motors Company, Denton, Texas, Mar. 2000, 2 page brochure.
 “Class Pays, Medium Duty,” Peterbilt Motors Company, Denton, Texas, Sep. 2000, 12-page brochure.
 “Class Pays, Platinum Interior,” Peterbilt Motors Company, Denton, Texas, May 2005, 4 page brochure.
 “Class Pays, Refuse Trucks,” Peterbilt Motors Company, Denton, Texas, Sep. 2003, 2 page brochure.
 “Class Pays, Truck Models,” Peterbilt Motors Company, Denton, Texas, Mar. 2005, 24-page brochure.
 “Class Pays,” Peterbilt Motors Company, Denton, Texas, Nov. 1998, 10 page brochure.
 “Class Pays,” Peterbilt Motors Company, Denton, Texas, September 1997, 10-page brochure.
 “Construction Trucks,” Canadian Kenworth Truck, Mississauga, Ontario, Canada, Jul. 1990, 16-page brochure.
 “Interiors,” Kenworth Truck Company, Kirkland, Washington, 2005, 16-page brochure.
 “K100E,” Kenworth Truck Company, Kirkland, Washington, 1984, 8-page brochure.
 “Model 320,” Peterbilt Motors Company, Denton, Texas, May 1996, 2 page brochure.
 “Model 330,” Peterbilt Motors Company, Denton, Texas, Oct. 1997, 3 page brochure.
 “Model 357 Heavy Haul,” Peterbilt Motors Company, Denton, Texas, Mar. 2005, 2 page brochure.
 “Model 357 Standard Specifications,” Peterbilt Motors Company, Newark, California, Sept. 1986, 6 page brochure.
 “Model 357, New Sloped Hood,” Peterbilt Motors Company, Denton, Texas, May 2002, 2 page brochure.
 “Model 357,” Peterbilt Motors Company, Denton, Texas, May 1994, 3-page brochure.
 “Model 357-115,” Peterbilt Motors Company, Denton, Texas, Mar. 2005, 2 page brochure.

“Model 362,” Peterbilt Motors Company, Newark, California, 1985, 8-page brochure.

“Model 375 Standard Specifications,” Peterbilt Motors Company, Newark, California, Sep. 1986, 6 page brochure.

“Model 377A/E,” Peterbilt Motors Company, Denton, Texas, Aug. 1997, 2-page brochure.

“Model 377A/E,” Peterbilt Motors Company, Denton, Texas, Jan. 1995, 6-page brochure.

“Model 378,” Peterbilt Motors Company, Denton, Texas, Mar. 1998, 3-page brochure.

“Model 379,” Peterbilt Motors Company, Denton, Texas, Apr. 2005, 2-page brochure.

“Model 379,” Peterbilt Motors Company, Denton, Texas, Mar. 1996, 5-page brochure.

“Model 385,” Peterbilt Motors Company, Denton, Texas, Oct. 1996, 5 page brochure.

“Model 387,” Peterbilt Motors Company, Denton, Texas, Oct. 2002, 2-page brochure.

“Peterbilt Parts & Accessories,” Peterbilt Motors Company, Denton, Texas, catalog, as early as 2000, 52-page brochure.

“Rest with Class,” Peterbilt Motors Company, Newark, California, Apr. 1978, 4-page brochure.

“Studio Sleeper,” Kenworth Truck Company, Kirkland, Washington, 1993, 5-page brochure.

“T2000,” Kenworth Truck Company, Kirkland, Washington, 1999, 20-page brochure.

“T2000,” Kenworth Truck Company, Kirkland, Washington, 2002, 20-page brochure.

“T2000,” Kenworth Truck Company, Kirkland, Washington, 2005, 20-page brochure.

“T270 Class 6 and T370 Class 7,” Kenworth Truck Company, Kirkland, Washington, 2008, 6-page brochure.

“T300,” Kenworth Truck Company, Kirkland, Washington, 1994, 4-page brochure.

“T300,” Kenworth Truck Company, Kirkland, Washington, 1997, 5-page brochure.

“T300,” Kenworth Truck Company, Kirkland, Washington, 2001, 16-page brochure.

“T300,” Kenworth Truck Company, Kirkland, Washington, 2005, 16-page brochure.

“T400B and T450B,” Kenworth Truck Company, Kirkland, Washington, 1992, 10-page brochure.

“T440,” Kenworth Truck Company, Kirkland, Washington, 2010, 2-page brochure.

“T470H,” Kenworth Truck Company, Kirkland, Washington, 2009, 2-page brochure.

“T600, Ten Years of Innovation,” Kenworth Truck Company, Kirkland, Washington, 1995, 6-page brochure.

“T600,” Kenworth Truck Company, Kirkland, Washington, 1996, 7-page brochure.

“T600,” Kenworth Truck Company, Kirkland, Washington, 2002, 28-page brochure.

“T600,” Kenworth Truck Company, Kirkland, Washington, 2005, 24-page brochure.

“T600A,” Kenworth Truck Company, Kirkland, Washington, 1985, 10-page brochure.

* cited by examiner

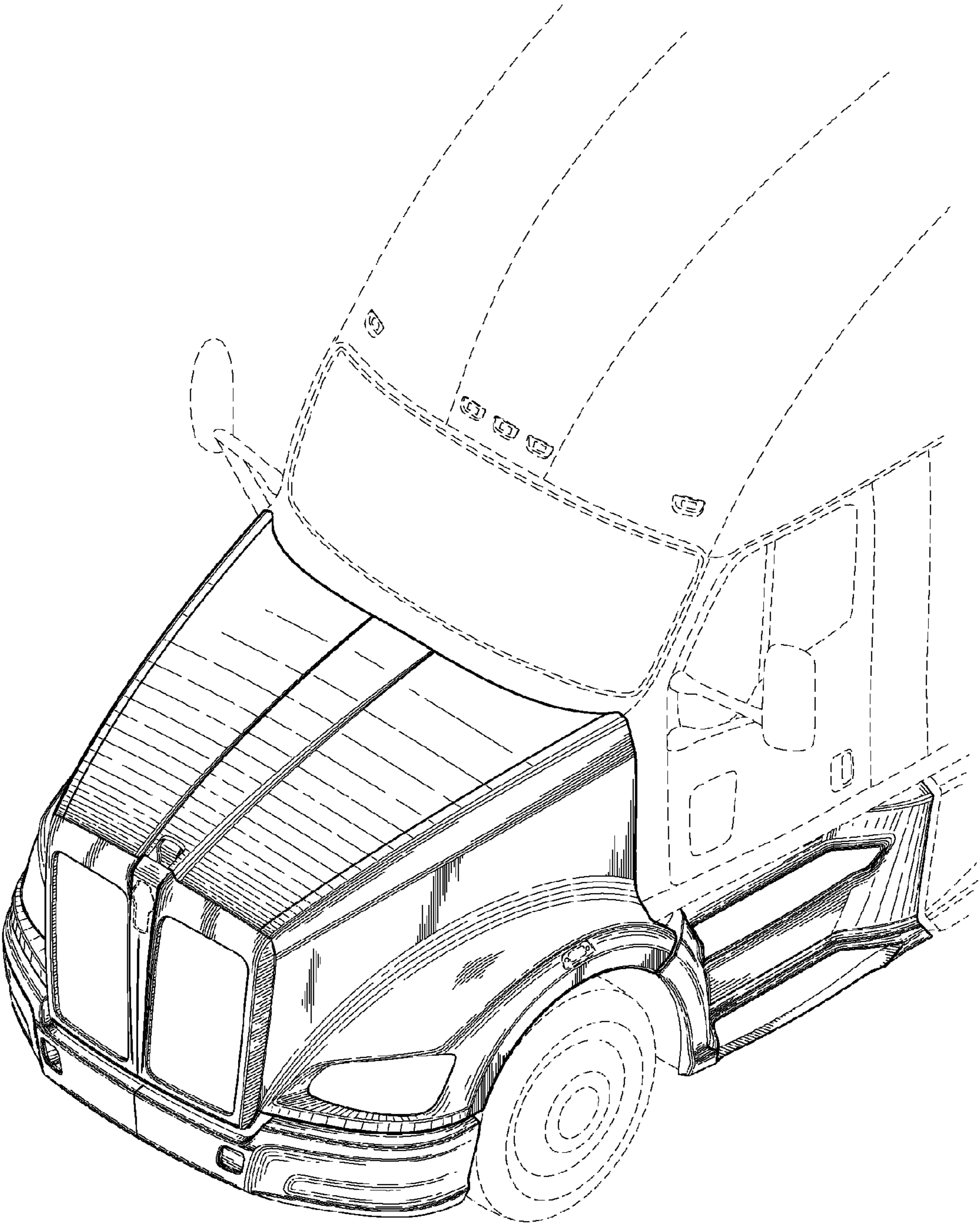

Fig. 1.

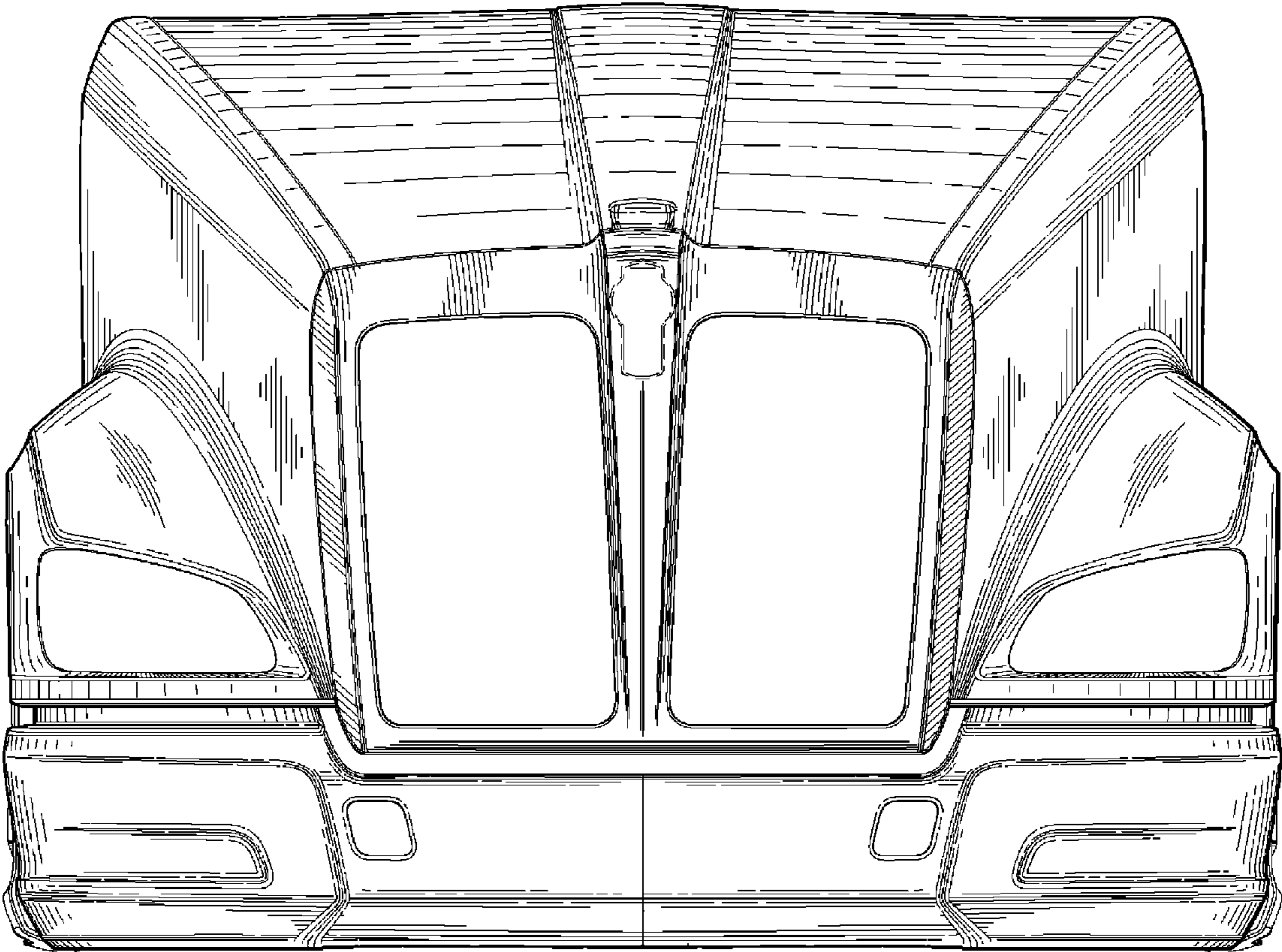

Fig. 2.

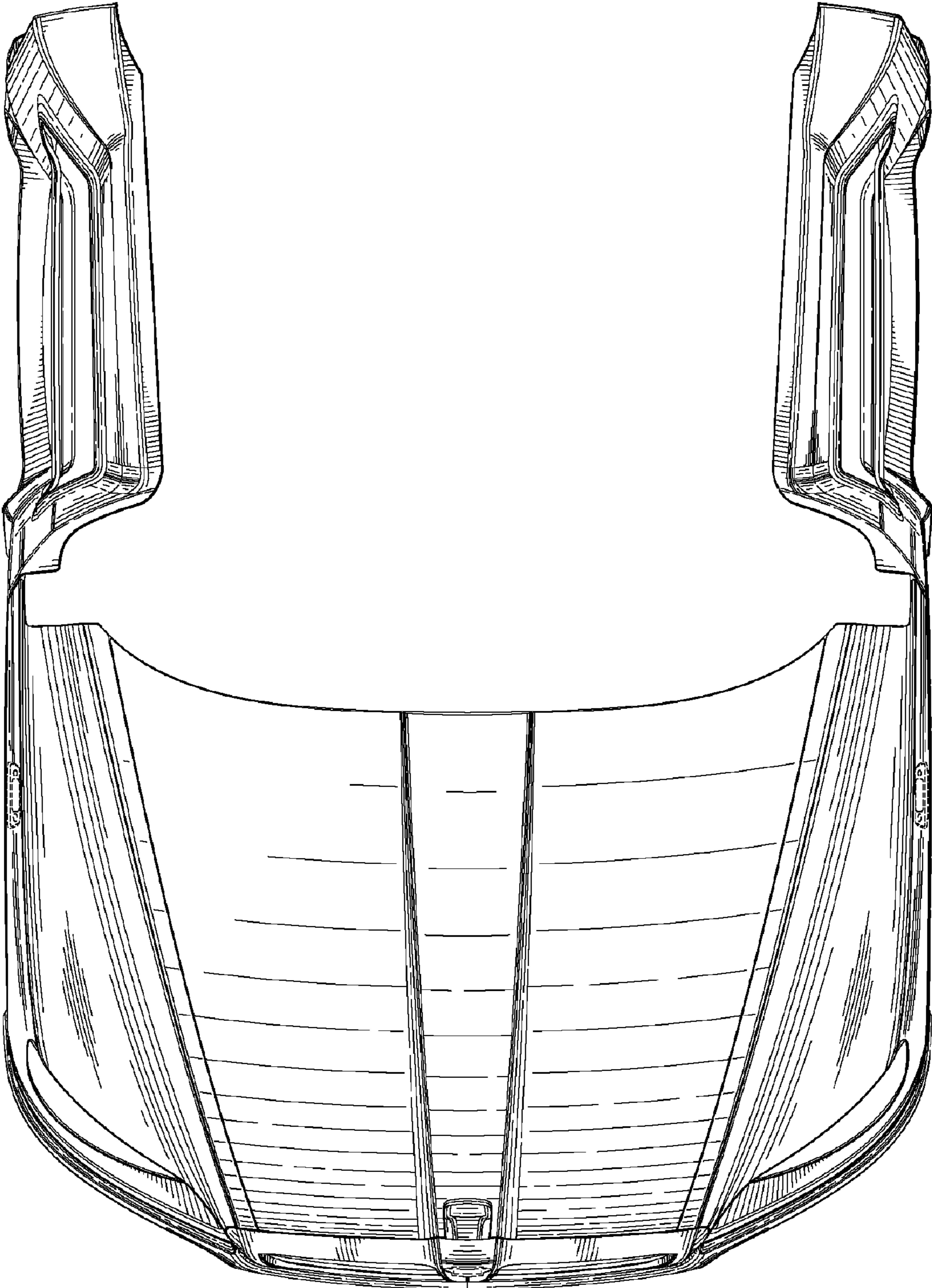

Fig. 3.

