



US00D632219S

(12) **United States Design Patent**  
**Lavoie**

(10) **Patent No.:** **US D632,219 S**  
(45) **Date of Patent:** **\*\* Feb. 8, 2011**

(54) **SNOWBOARD/SKI CARRIER FOR A SNOWMOBILE**

(76) Inventor: **Brian Lavoie**, 2058 Transcanada Highway, Golden, BC (CA) V0A 1H1

(\*\*) Term: **14 Years**

(21) Appl. No.: **29/314,337**

(22) Filed: **Mar. 20, 2009**

(51) **LOC (9) Cl.** ..... **12-14**

(52) **U.S. Cl.** ..... **D12/7; D12/400**

(58) **Field of Classification Search** ..... D12/7,  
D12/8, 9, 400; 224/408; 280/900; D8/354,  
D8/349

See application file for complete search history.

(56) **References Cited**

**U.S. PATENT DOCUMENTS**

3,785,541	A *	1/1974	Sibley	.....	224/408
4,950,010	A *	8/1990	Denny	.....	293/117
D359,466	S *	6/1995	Eggers et al.	.....	D12/115
6,823,957	B2 *	11/2004	Girouard et al.	.....	180/190
7,025,161	B2 *	4/2006	Bertrand et al.	.....	180/190
D616,287	S *	5/2010	Lavoie	.....	D8/354

\* cited by examiner

*Primary Examiner*—T. Chase Nelson  
*Assistant Examiner*—Ania K Dworzecka  
(74) *Attorney, Agent, or Firm*—Brownstein Hyatt Farber Schreck, LLP

(57) **CLAIM**

The ornamental design for a snowboard/ski carrier for a snowmobile, as shown and described.

**DESCRIPTION**

FIG. 1 is a side perspective view of a snowboard/ski carrier showing my new design;

FIG. 2 is a front elevation view of the carrier;

FIG. 3 is a left side elevation view of the carrier;

FIG. 4 is a top plan view of the carrier;

FIG. 5 is a side perspective view of the carrier showing a second embodiment;

FIG. 6 is a front elevation view of the carrier according to the second embodiment;

FIG. 7 is a left side elevation view of the carrier according to the second embodiment;

FIG. 8 is a top plan view of the carrier according to the second embodiment;

FIG. 9 is a side perspective view of the carrier according the third embodiment;

FIG. 10 is a front elevation view of the carrier according to the third embodiment;

FIG. 11 is left side elevation view of the carrier according o the third embodiment; and,

FIG. 12 is a top plan view of the carrier according to the third embodiment.

The broken lines are for purposes of illustrating environmental structure and form no part of the claimed design.

**1 Claim, 6 Drawing Sheets**

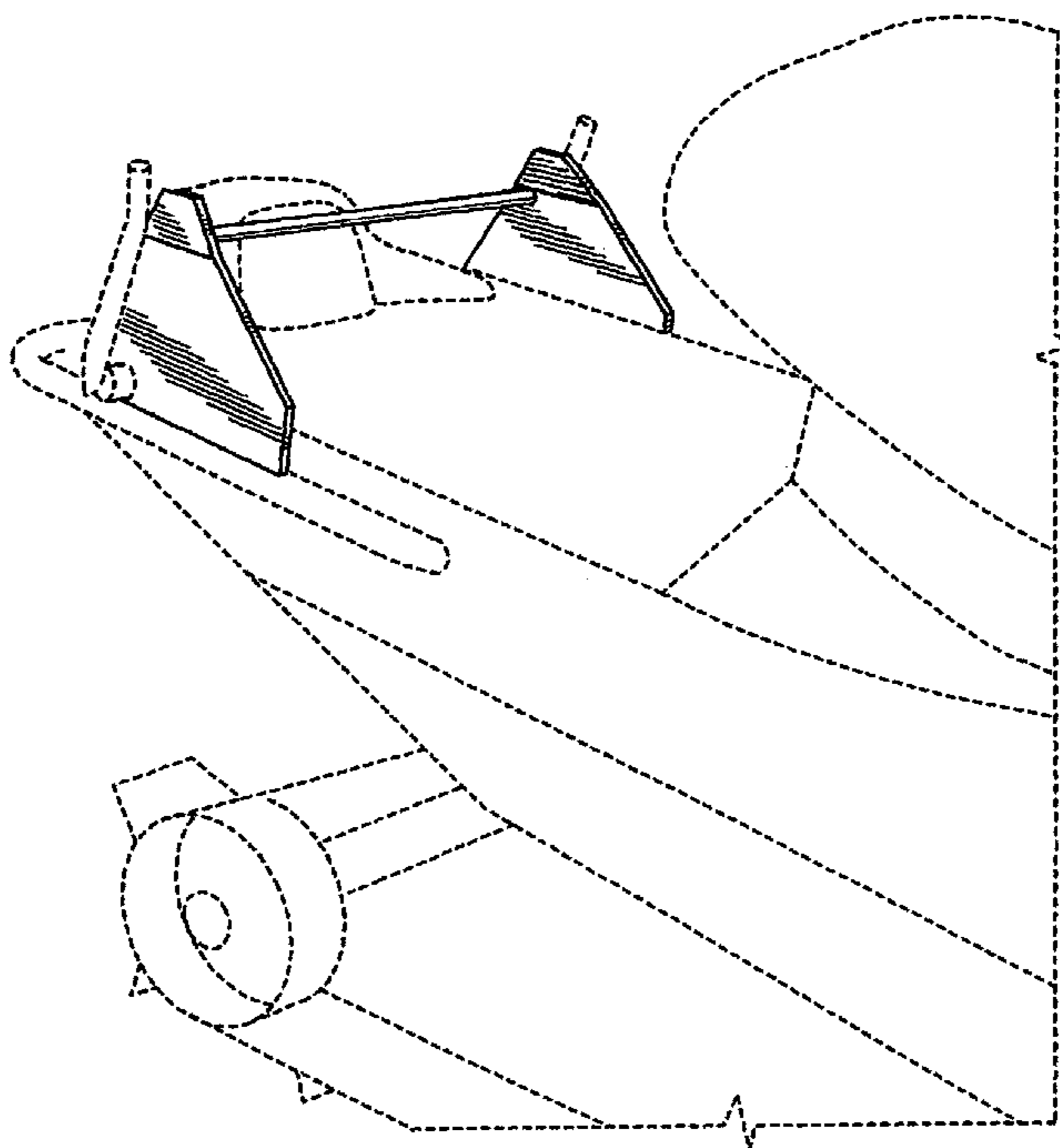

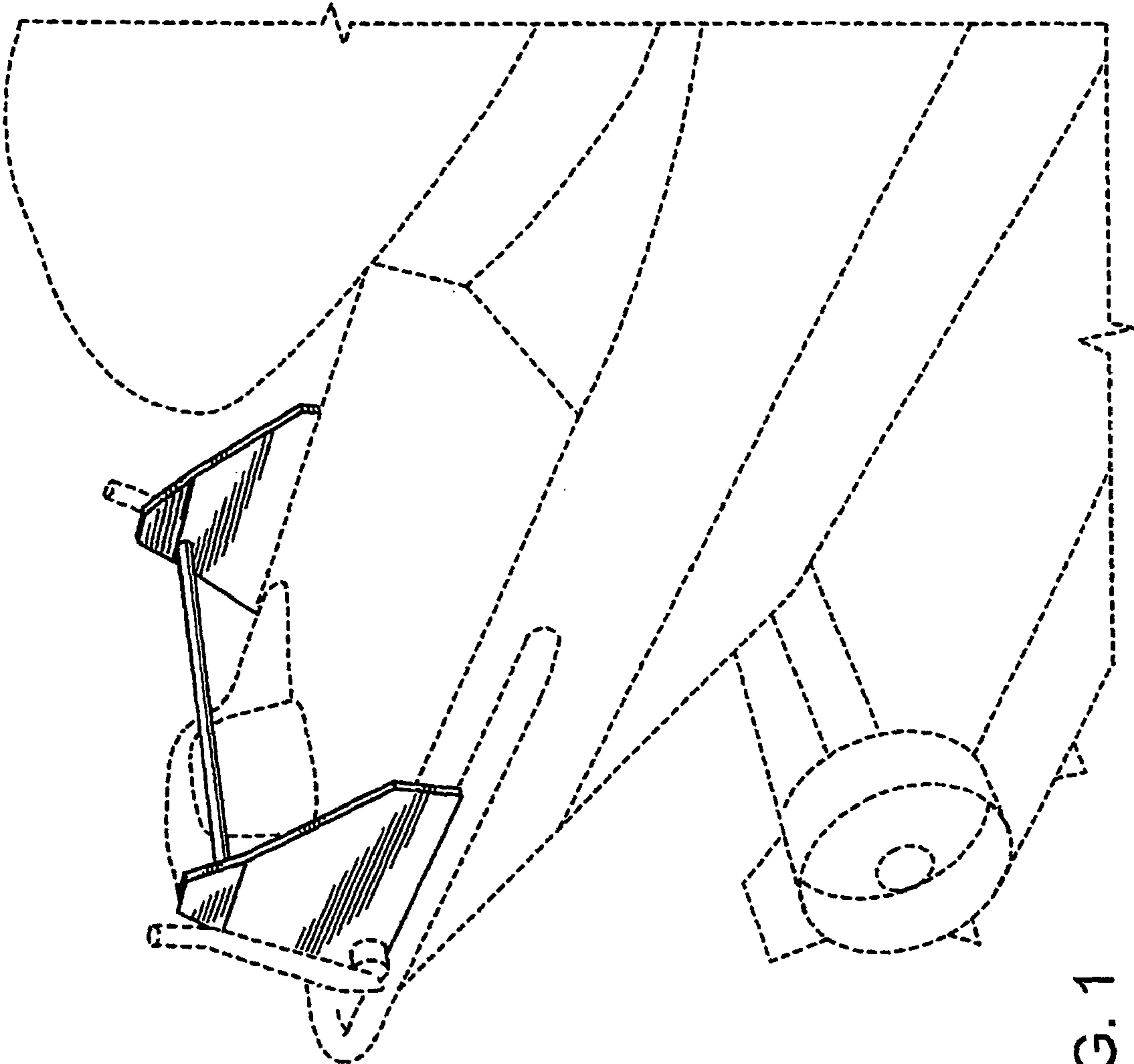

FIG. 1

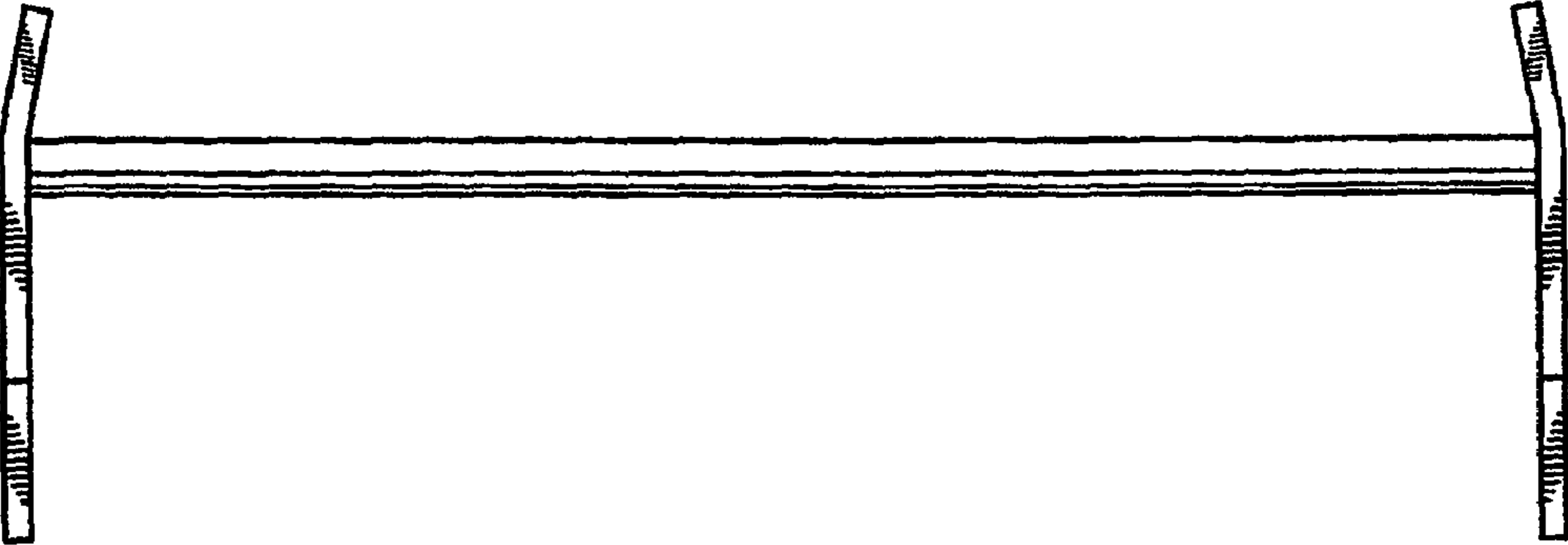

FIG. 2

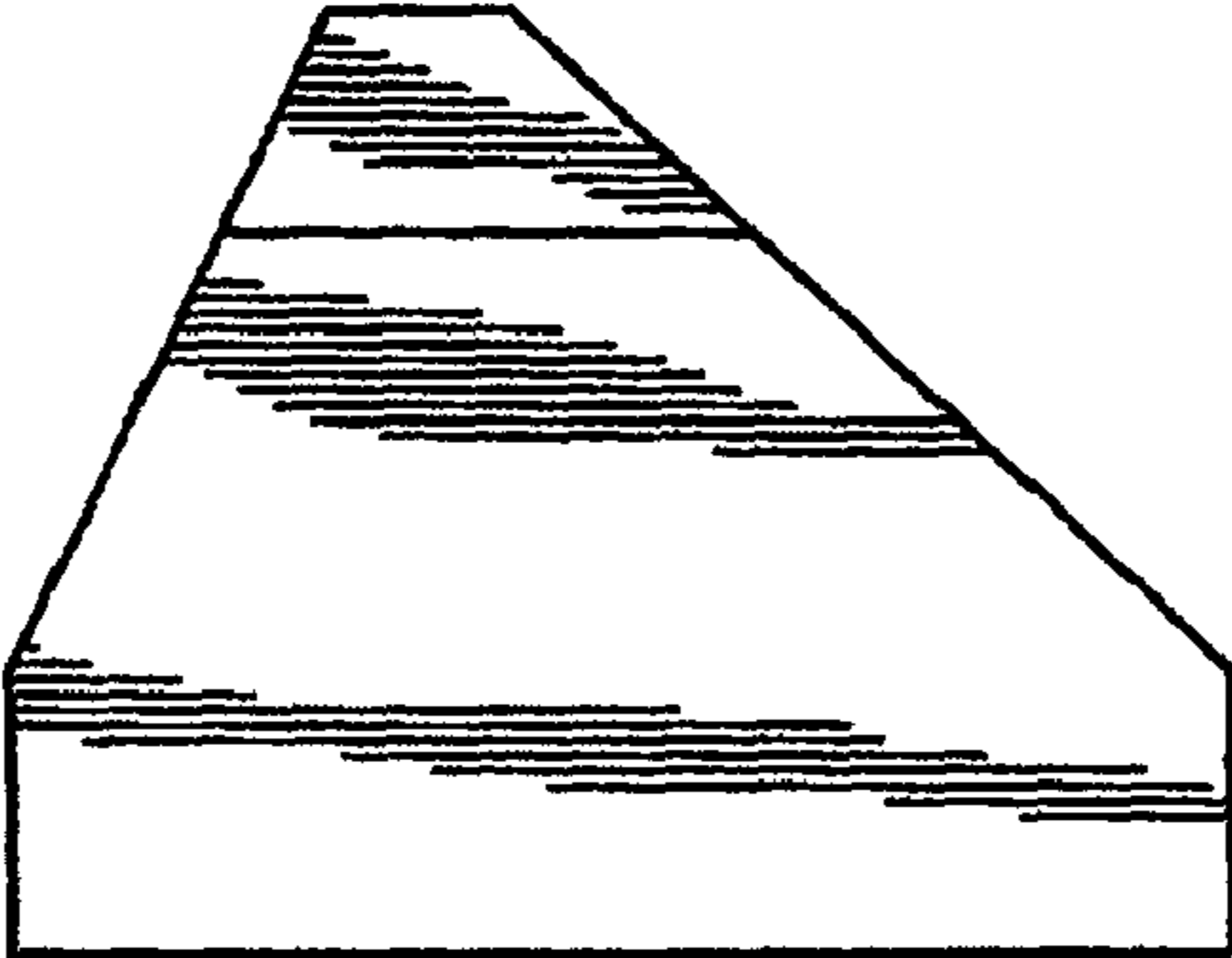

FIG. 3

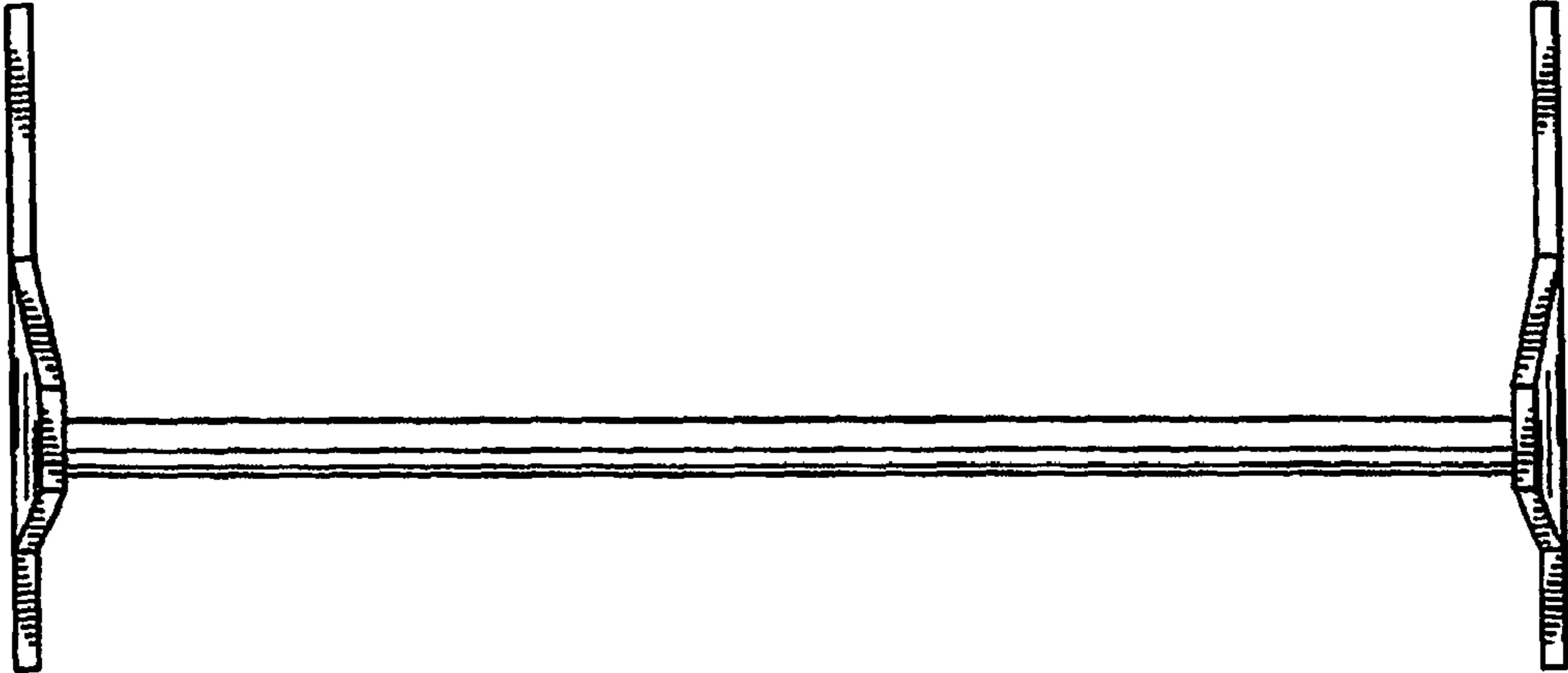

FIG. 4

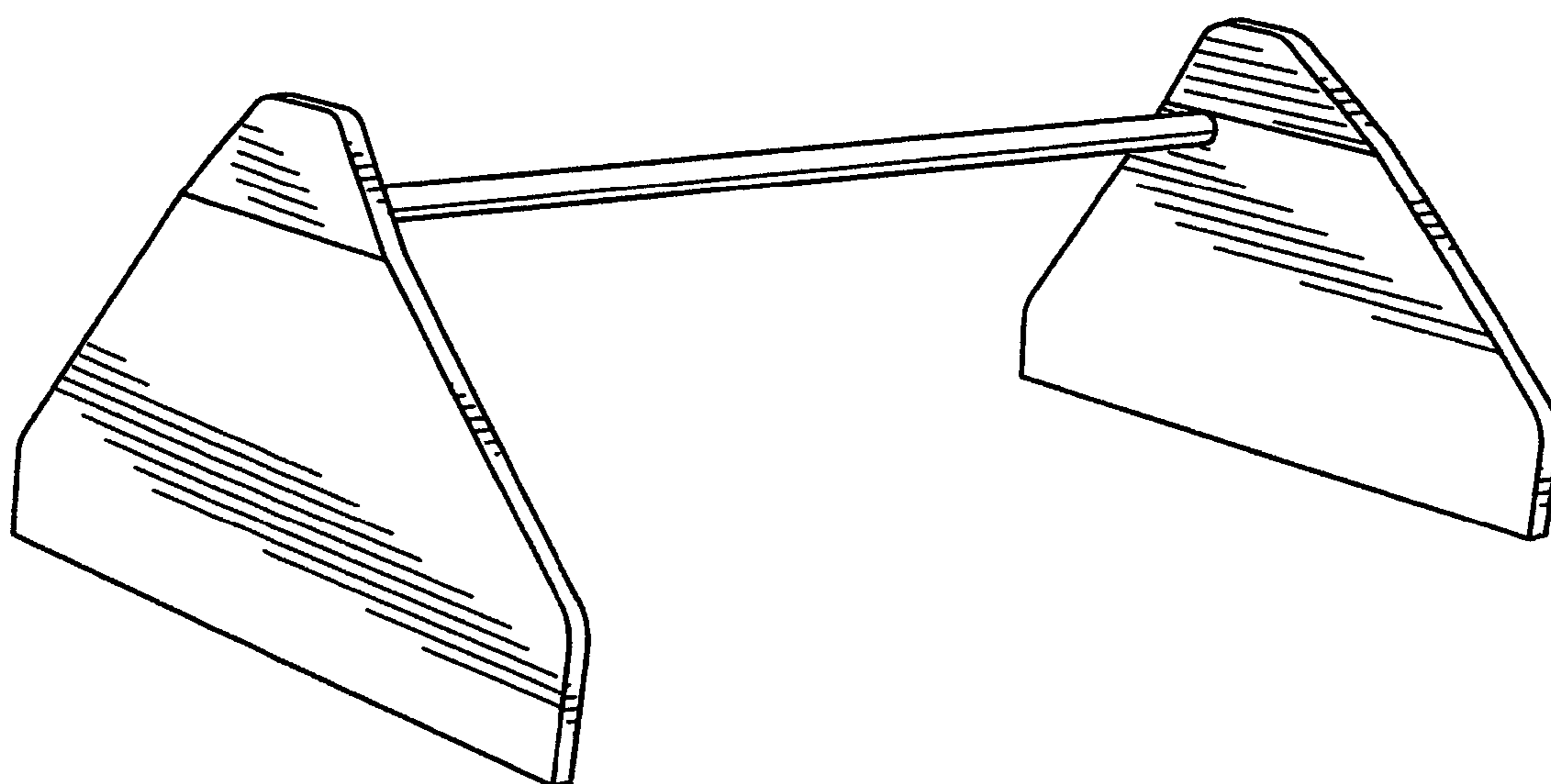

FIG. 5

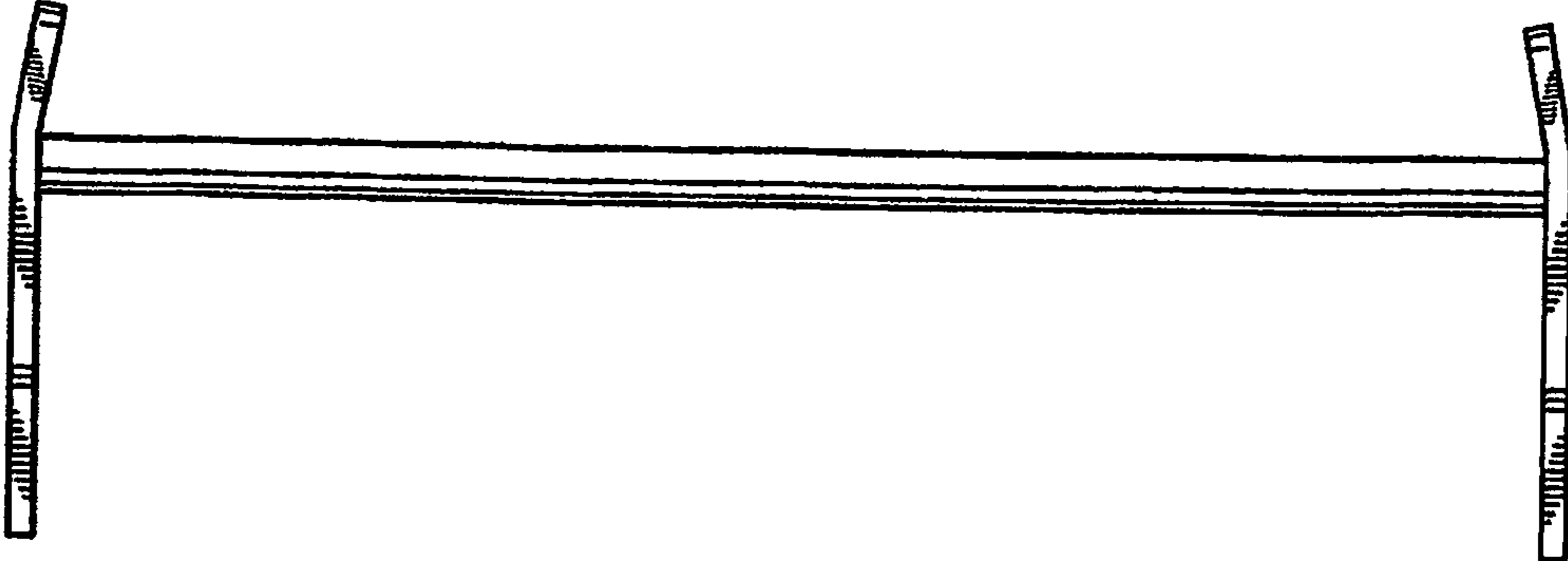

FIG. 6

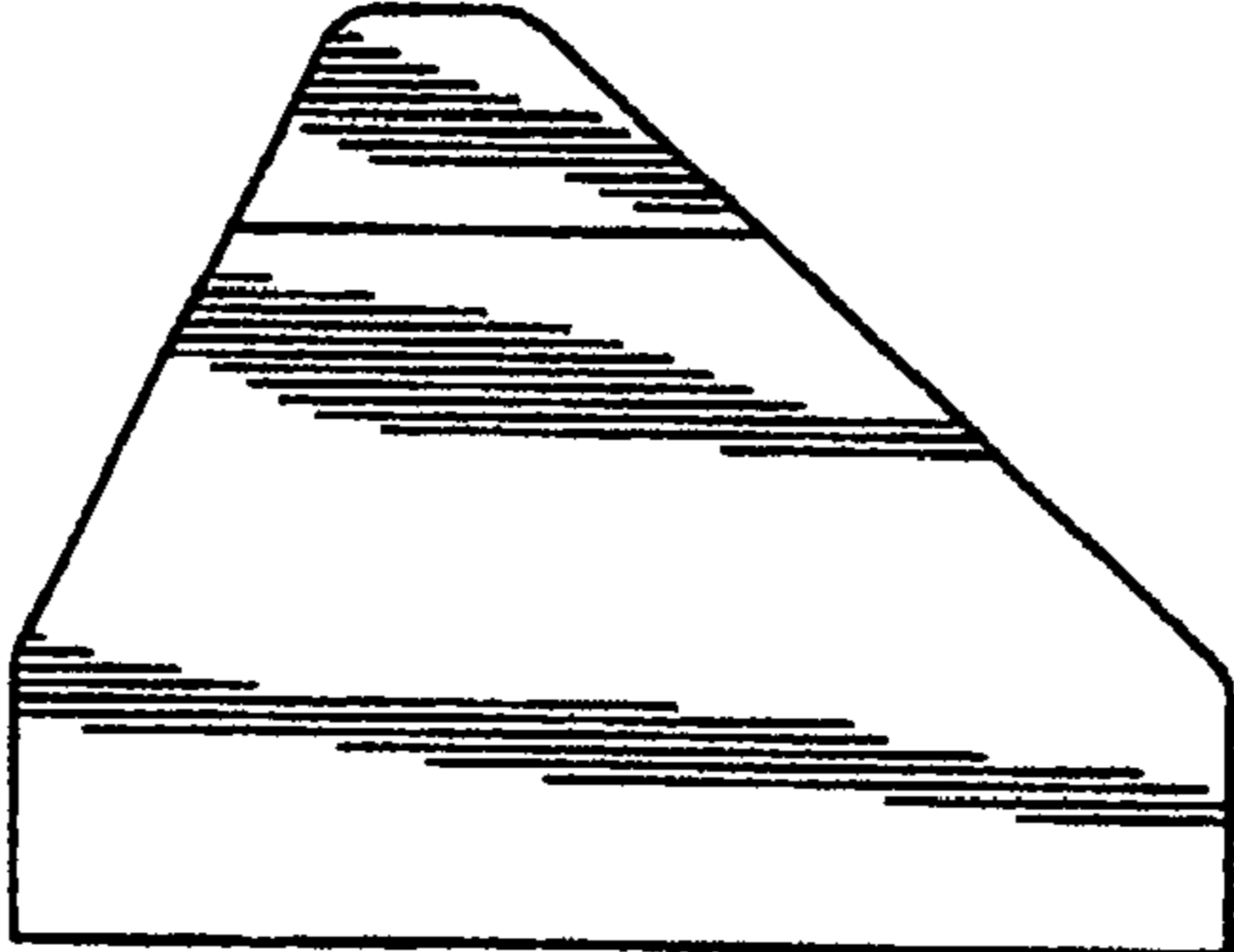

FIG. 7

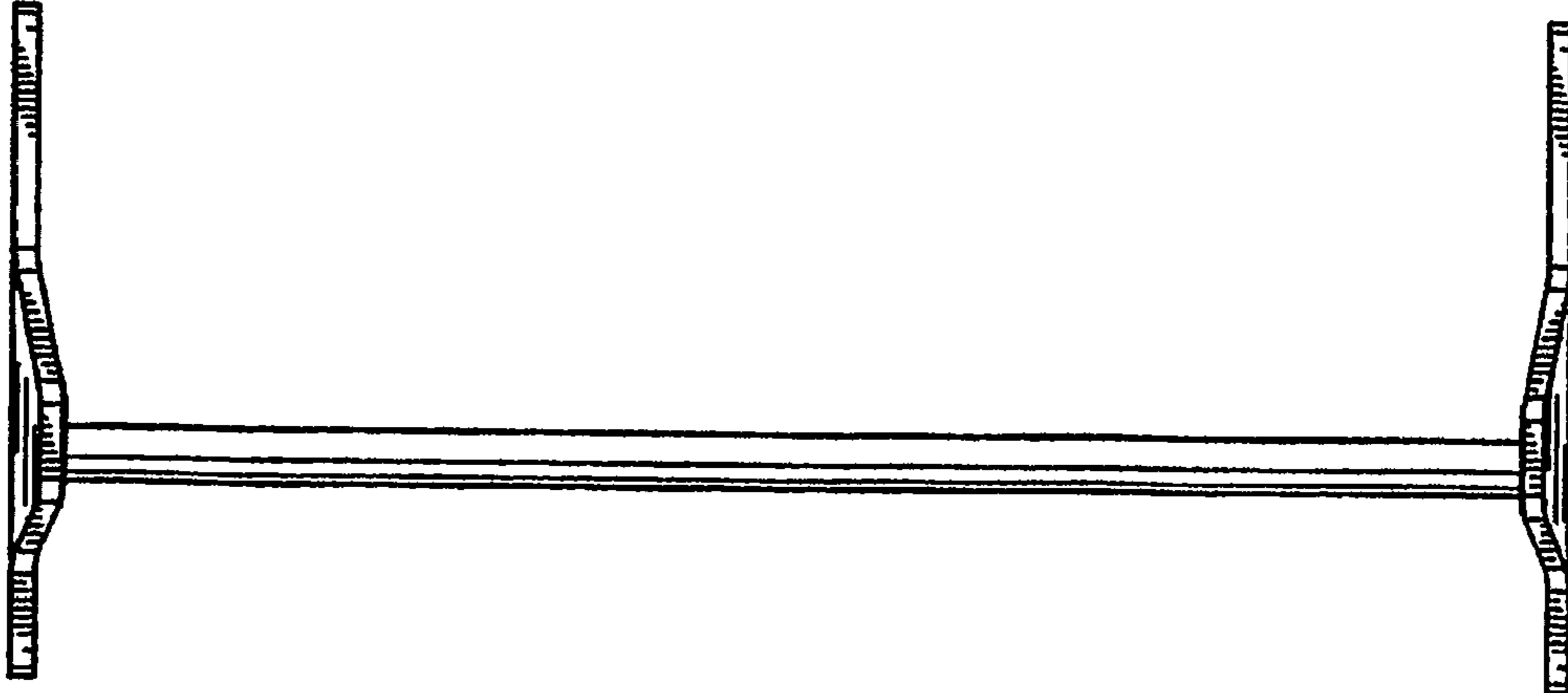

FIG. 8

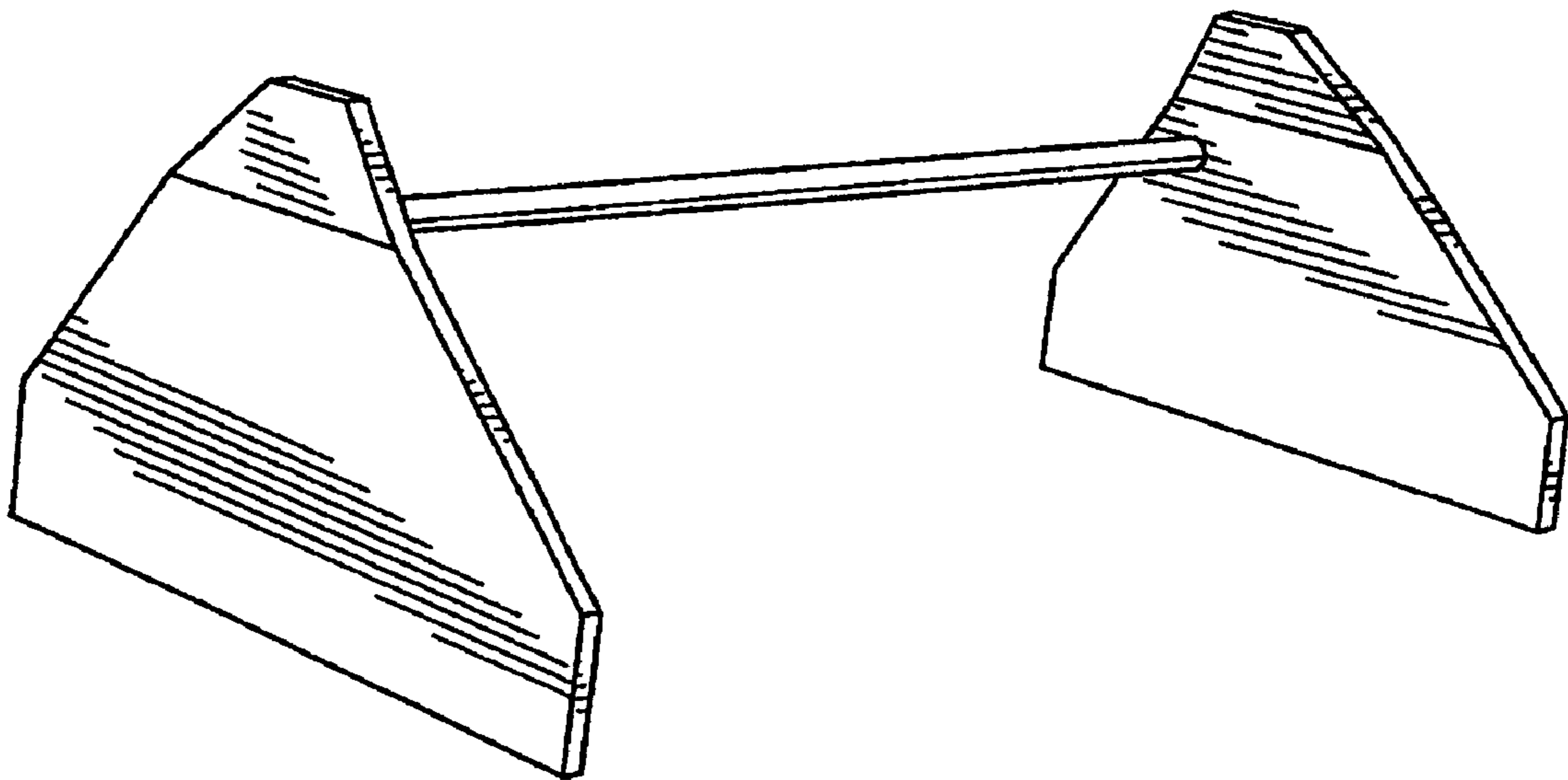

FIG. 9

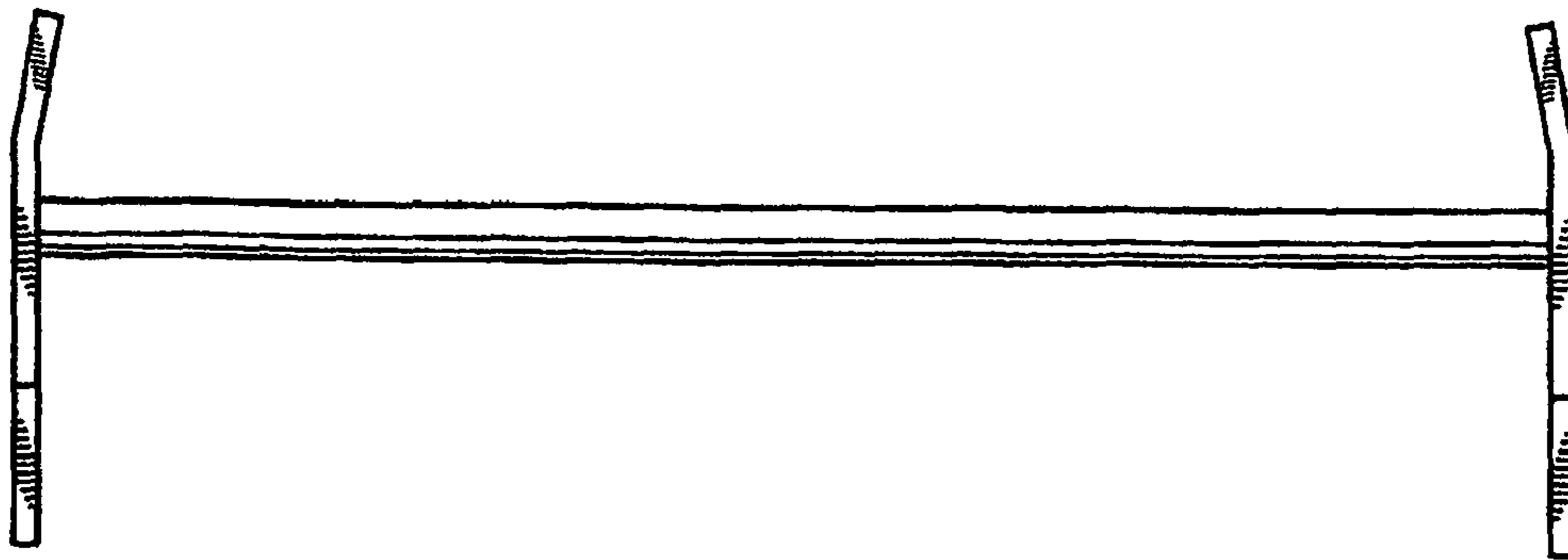

FIG. 10

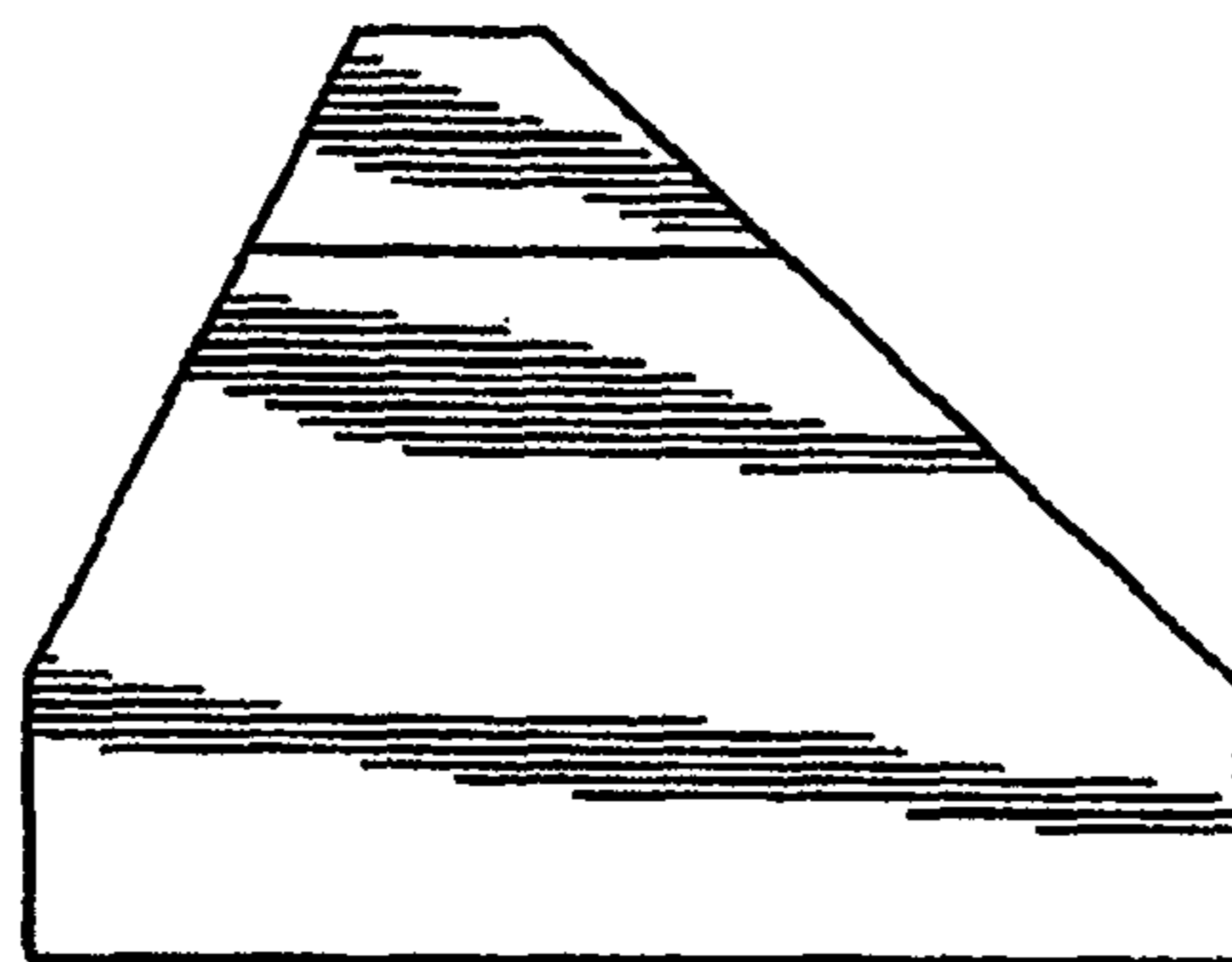

FIG. 11

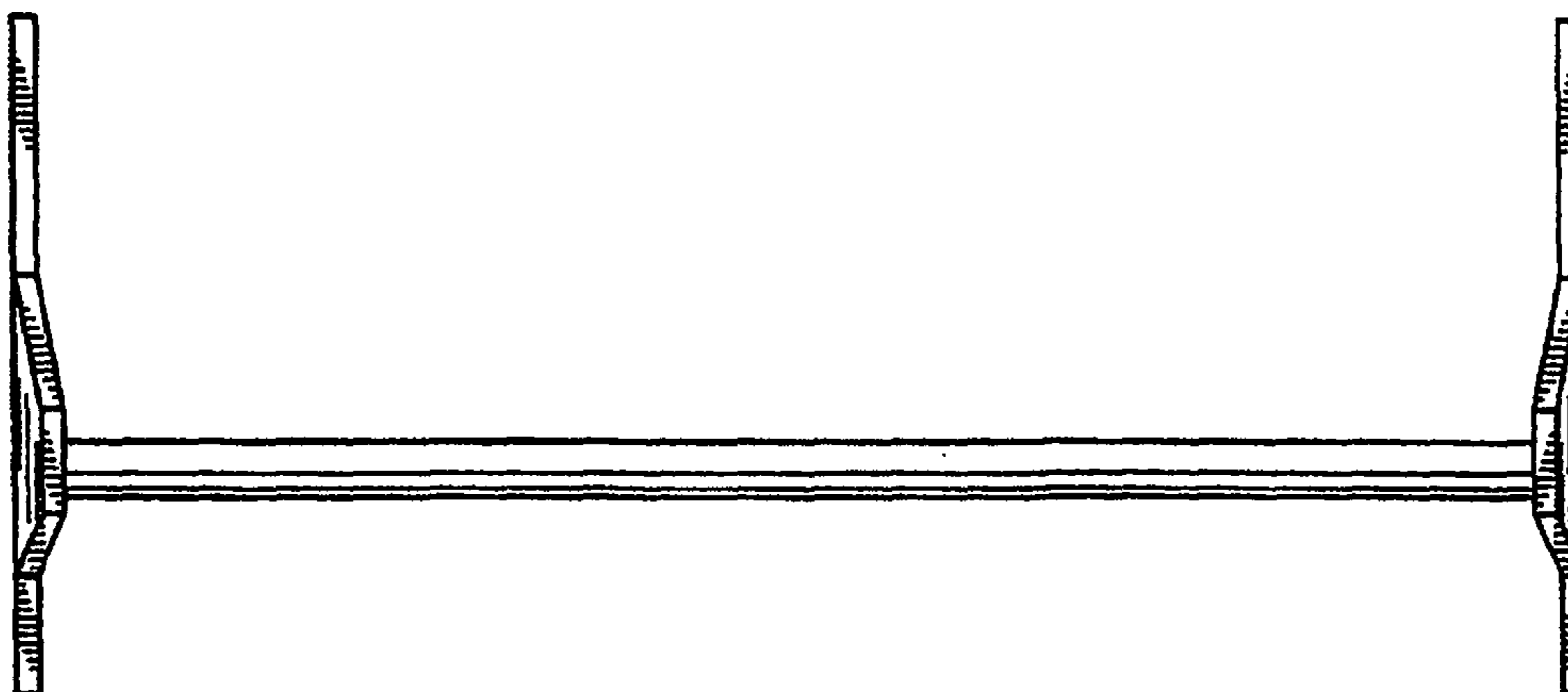

FIG. 12