



US00D631979S

(12) **United States Design Patent**  
**Kennedy et al.**

(10) **Patent No.:** **US D631,979 S**

(45) **Date of Patent:** **\*\* Feb. 1, 2011**

(54) **LADDER STOP**

(75) Inventors: **Neil J. Kennedy**, Woodbury, CT (US);  
**Andrew James Hughes**, New Hartforn,  
CT (US); **Joseph R. Flaherty**, Propect,  
CT (US); **Thomas Joel Anderson**,  
Hamden, CT (US)

(73) Assignee: **Thule Sweden AB**, Hillerstorp (SE)

(\*\*) Term: **14 Years**

(21) Appl. No.: **29/355,000**

(22) Filed: **Feb. 1, 2010**

(51) **LOC (9) Cl.** ..... **25-04**

(52) **U.S. Cl.** ..... **D25/68**

(58) **Field of Classification Search** ..... D25/68;  
182/107, 108; 248/210, 238; 224/405  
See application file for complete search history.

(56) **References Cited**

U.S. PATENT DOCUMENTS

|           |      |         |              |       |         |
|-----------|------|---------|--------------|-------|---------|
| 3,904,094 | A *  | 9/1975  | Correll      | ..... | 224/324 |
| D356,166  | S *  | 3/1995  | Spiller      | ..... | D25/68  |
| 5,829,654 | A *  | 11/1998 | Weger et al. | ..... | 224/322 |
| 6,971,563 | B2 * | 12/2005 | Levi         | ..... | 224/405 |
| 7,757,813 | B2 * | 7/2010  | Kerr         | ..... | 182/39  |

\* cited by examiner

*Primary Examiner*—Doris Clark  
(74) *Attorney, Agent, or Firm*—Novak Druce + Quigg, LLP

(57) **CLAIM**

We claim the ornamental design for a ladder stop, as shown and described.

**DESCRIPTION**

FIG. 1 is a perspective view of a ladder stop;  
FIG. 2 is a right side elevational view thereof;  
FIG. 3 is a left side elevational view thereof;  
FIG. 4 is a top plan view thereof;  
FIG. 5 is a bottom plan view thereof;  
FIG. 6 is a front elevational view thereof;  
FIG. 7 is a rear elevational view thereof;  
FIG. 8 is a cross sectional view taken along line 8—8 of FIG. 3;  
FIG. 9 is a cross sectional view taken along line 9—9 of FIG. 2;  
FIG. 10 is a perspective view of the ladder stop attached to a carrier rack; and,  
FIG. 11 is another perspective view of the ladder stop attached to a ladder and the carrier rack.  
The broken lines are for illustrative purposes only and form no part of the claimed design.

**1 Claim, 7 Drawing Sheets**

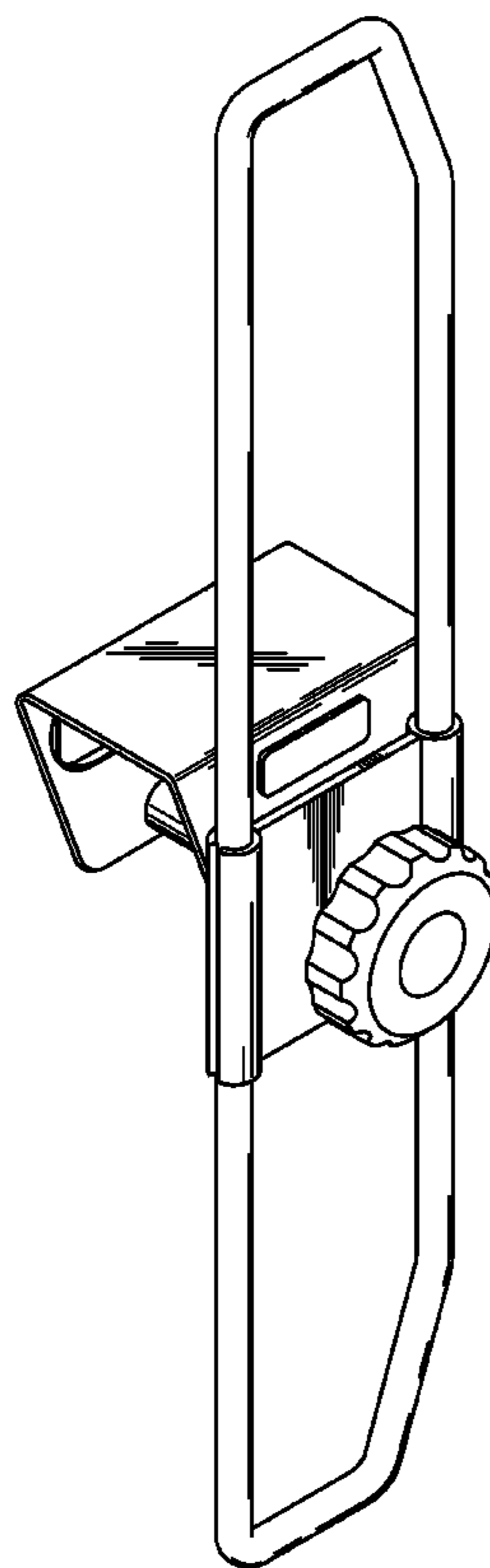

Fig. 1

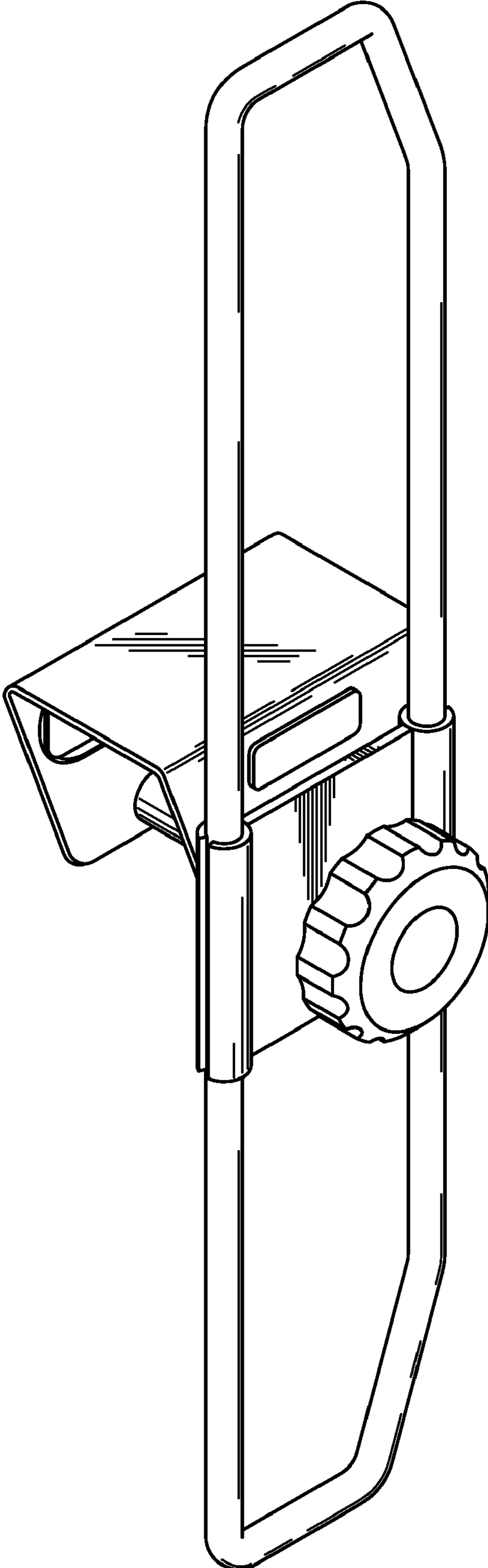

Fig. 2

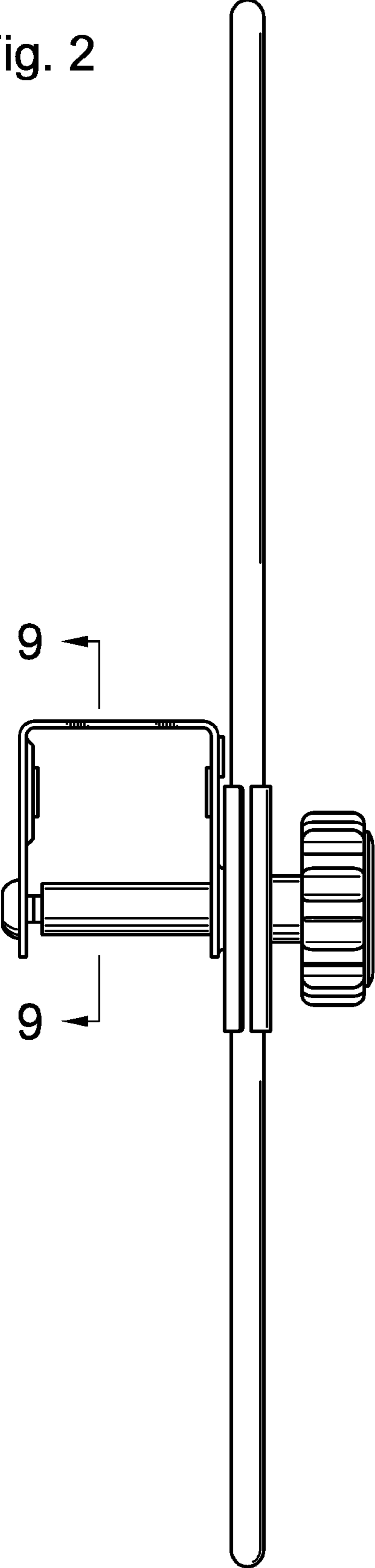

Fig. 3

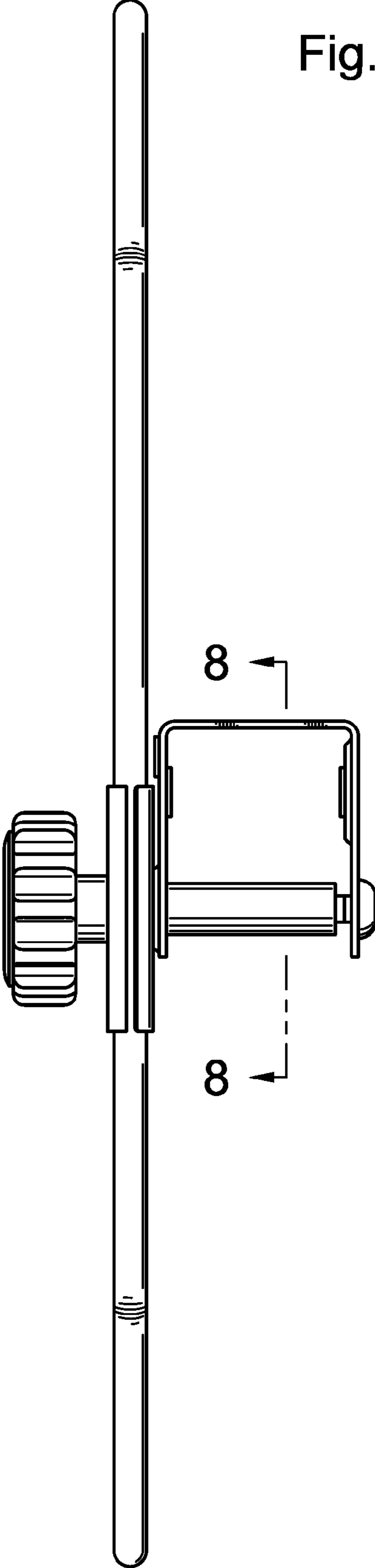

Fig. 4

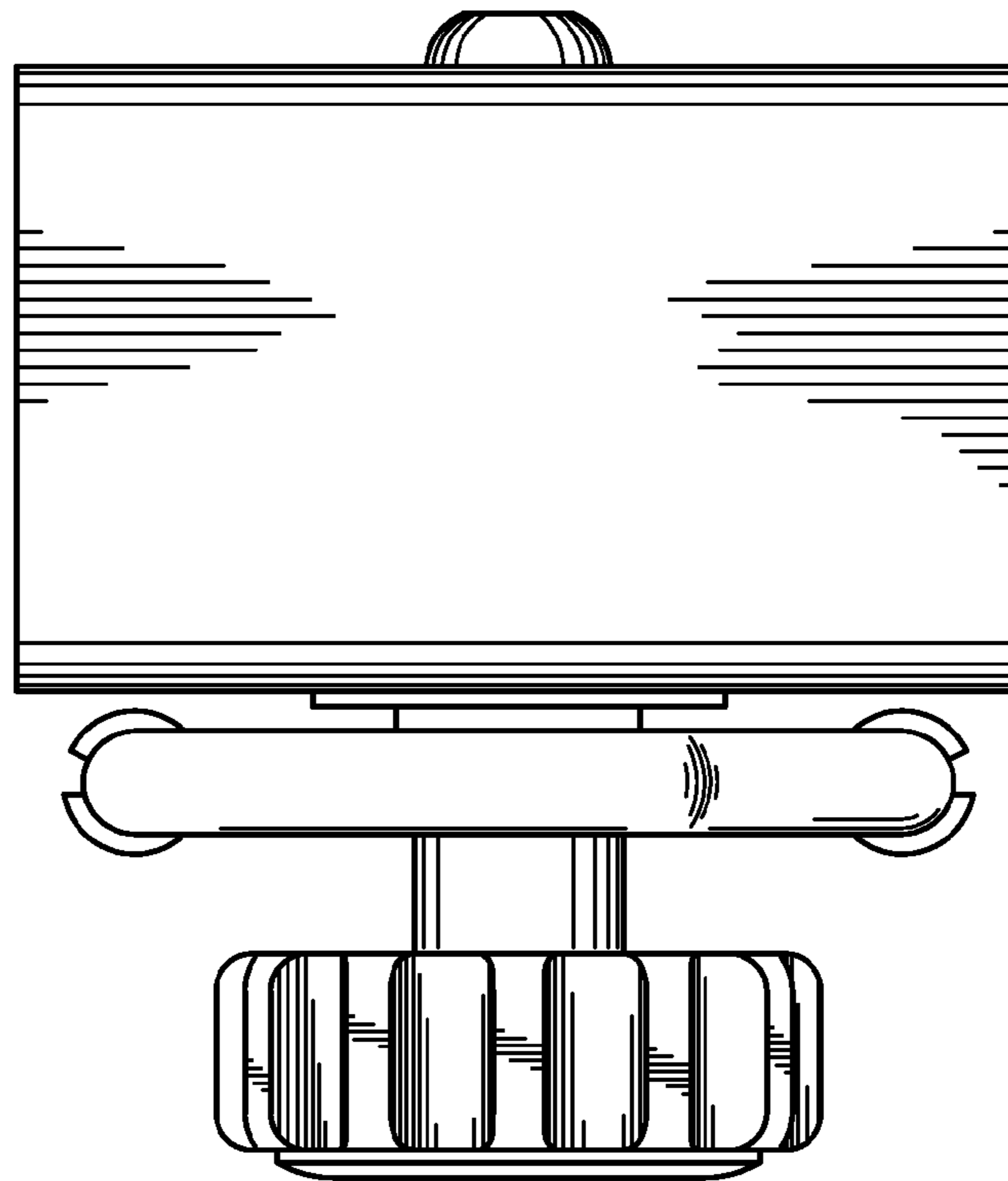

Fig. 5

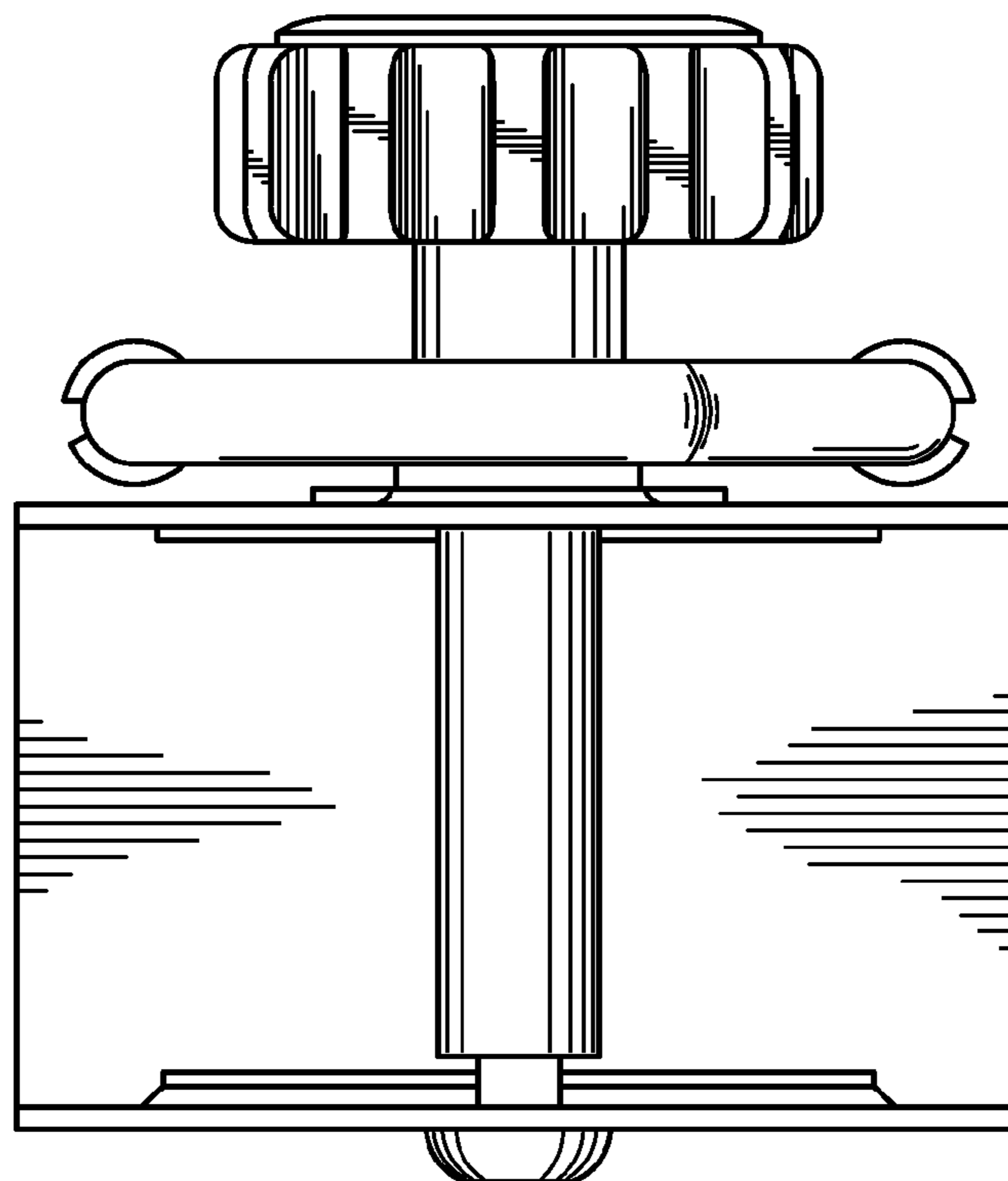

Fig. 6

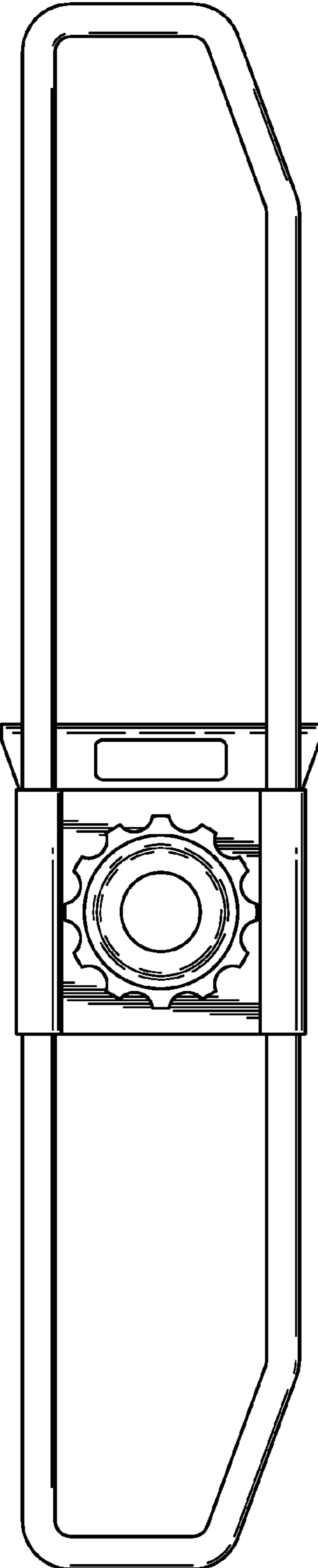
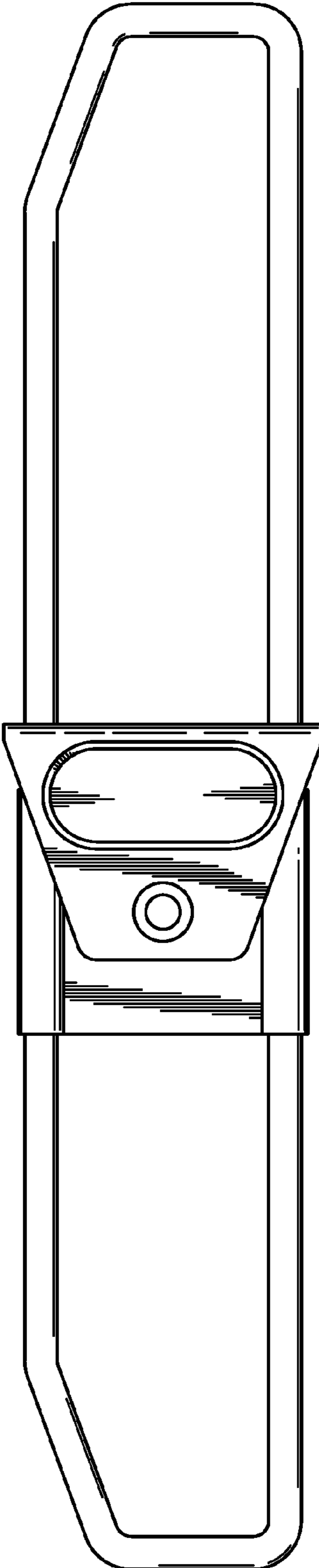

Fig. 7



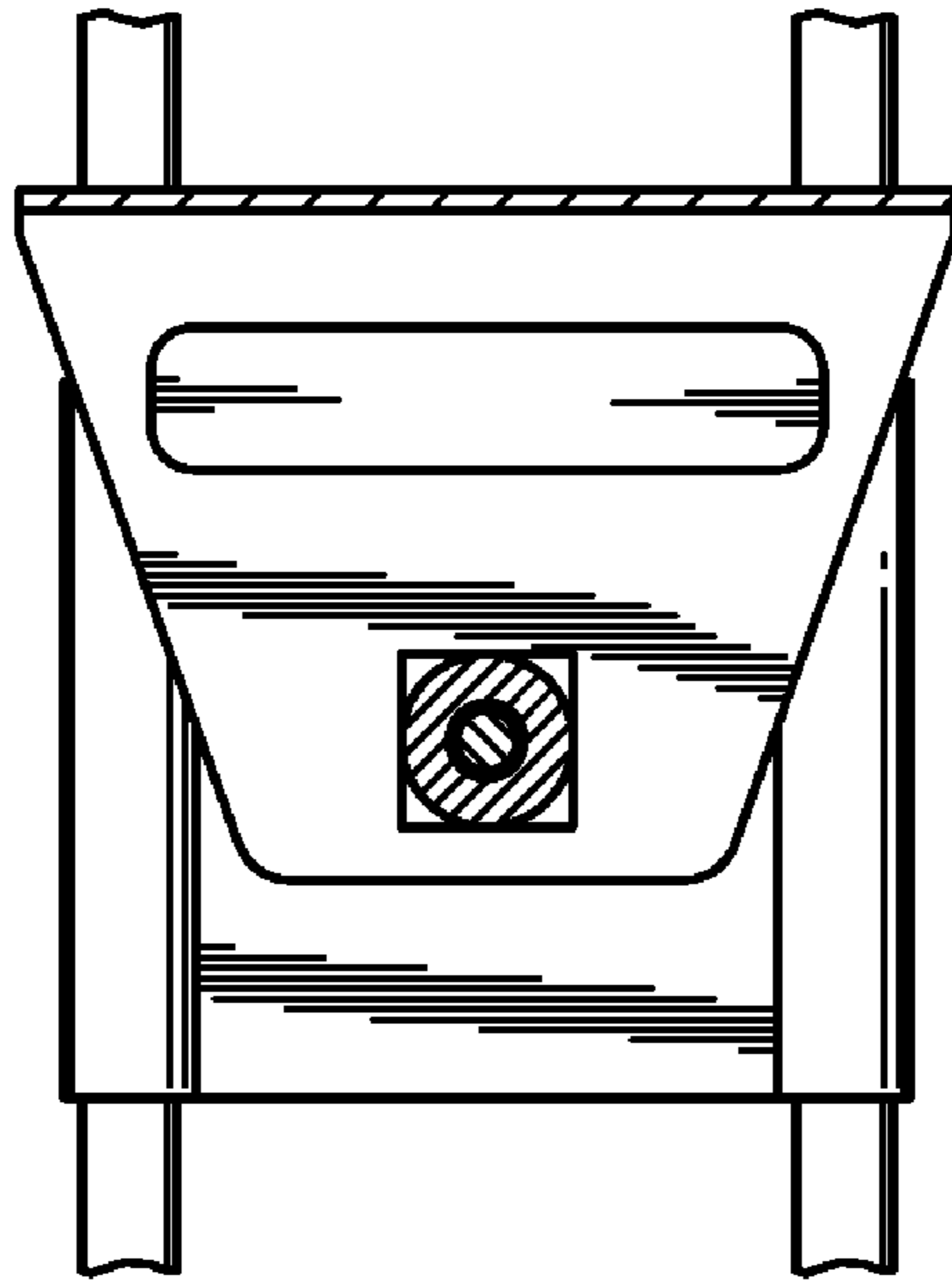

Fig. 8

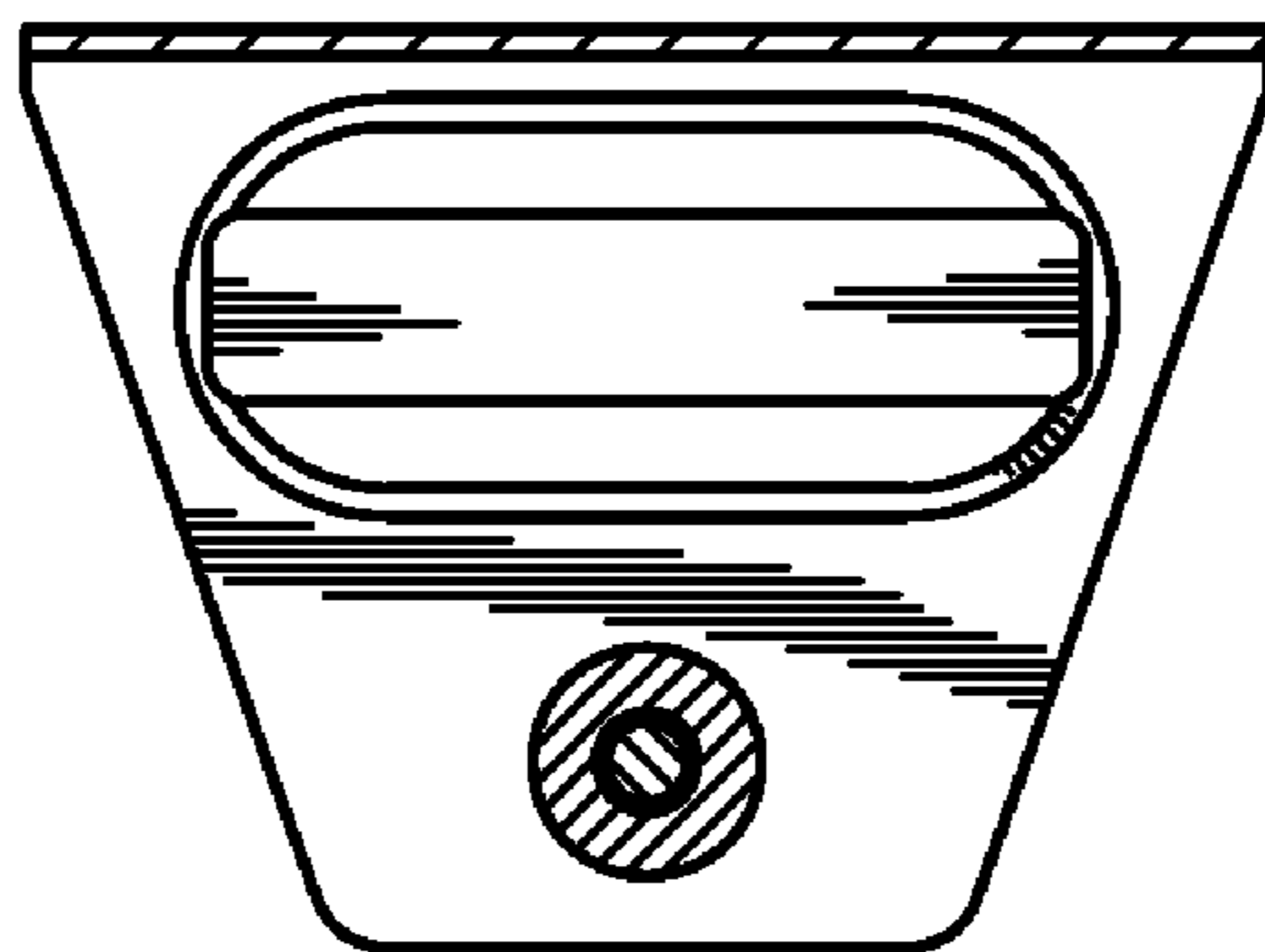

Fig. 9

Fig. 10

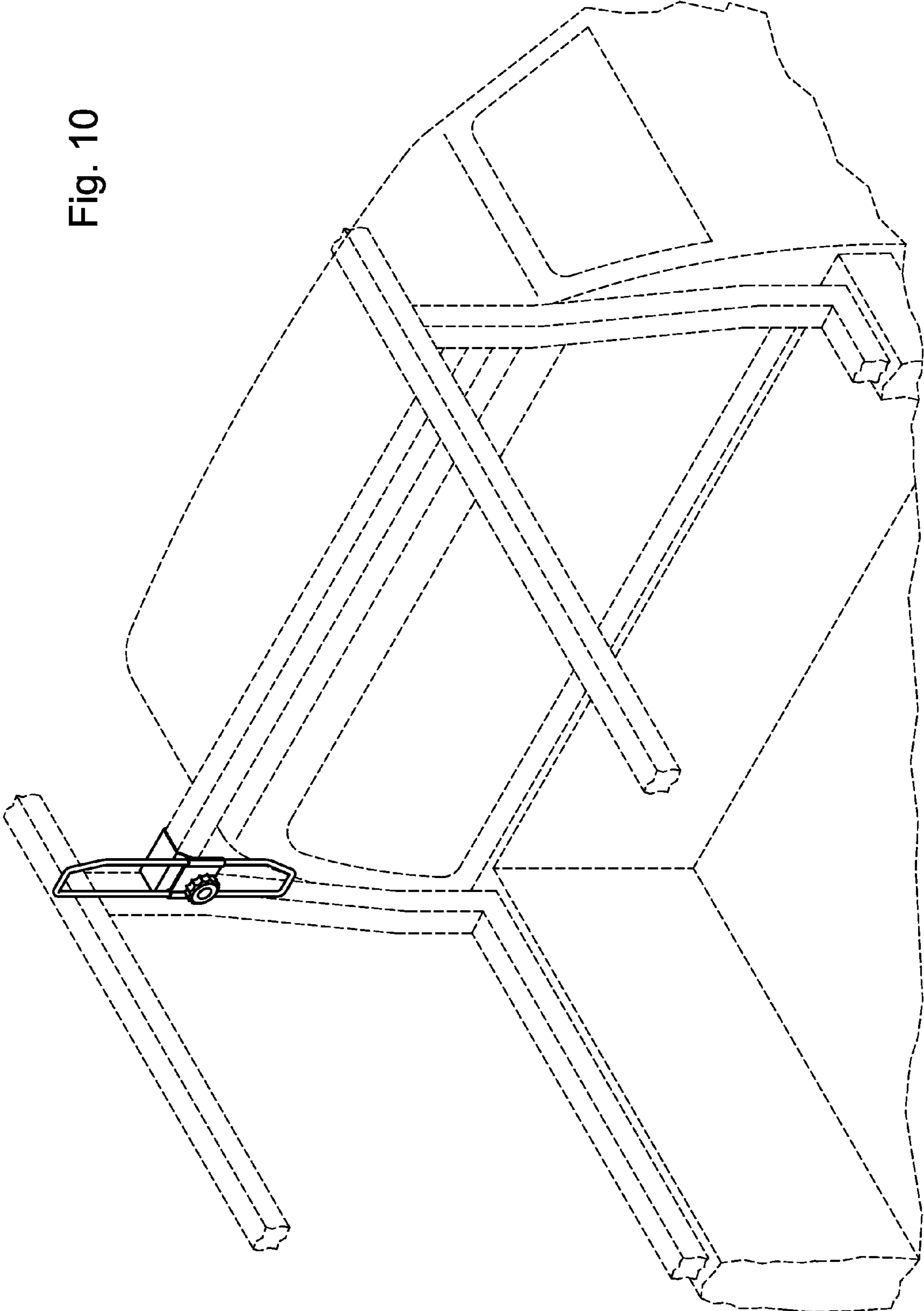



Fig. 11

