

US00D631807S

(12) **United States Design Patent**
Clottu

(10) **Patent No.:** **US D631,807 S**

(45) **Date of Patent:** **** Feb. 1, 2011**

(54) **DECORATIVE ELEMENT FOR A VEHICLE**

EM 001104913-0001 4/2009

* cited by examiner

(75) Inventor: **Fabien Clottu**, Munich (DE)

Primary Examiner—Caron Veynar

(73) Assignee: **Bayerische Motoren Werke Aktiengesellschaft**, Munich (DE)

Assistant Examiner—Katrina A Kile

(74) *Attorney, Agent, or Firm*—Crowell & Moring LLP

(**) Term: **14 Years**

(57) **CLAIM**

(21) Appl. No.: **29/347,800**

The ornamental design for a decorative element for a vehicle, as shown and described.

(22) Filed: **Jun. 7, 2010**

(30) **Foreign Application Priority Data**

Dec. 8, 2009 (DE) 402009006095

(51) **LOC (9) Cl.** **12-08**

(52) **U.S. Cl.** **D12/190**

(58) **Field of Classification Search** D12/181,
D12/191, 196, 400, 190, 88; 280/727, 770,
280/848; 296/180.1–180.5, 91; 180/903
See application file for complete search history.

(56) **References Cited**

U.S. PATENT DOCUMENTS

| | | | | |
|--------------|---------|-------------------|-------|---------|
| D409,473 S * | 5/1999 | Tieu | | D8/342 |
| D493,399 S * | 7/2004 | Schowalter et al. | | D12/195 |
| D507,471 S * | 7/2005 | Schowalter et al. | | D8/306 |
| D540,714 S | 4/2007 | Mueller-Stolz | | |
| D566,022 S * | 4/2008 | Johnson | | D12/190 |
| D587,980 S * | 3/2009 | Rosenbohm | | D8/303 |
| D594,393 S * | 6/2009 | Pfeiffer | | D12/190 |
| D600,181 S * | 9/2009 | Larson | | D12/181 |
| D604,677 S * | 11/2009 | Schiavone et al. | | D12/163 |
| D605,084 S | 12/2009 | Szavits | | |
| D606,468 S * | 12/2009 | Varga | | D12/181 |
| D607,390 S * | 1/2010 | Krauss | | D12/190 |
| D609,149 S * | 2/2010 | Larson et al. | | D12/181 |
| D619,056 S * | 7/2010 | Lamm et al. | | D12/163 |
| D619,507 S * | 7/2010 | Ishibashi | | D12/163 |

FOREIGN PATENT DOCUMENTS

EM 000482419-00001 10/2006

1 Claim, 4 Drawing Sheets

DESCRIPTION

This application contains subject matter related to the following co-pending U.S. design patent applications:

Application Ser. No. 29/347,801, filed herewith and entitled “Vehicle, Toy, and/or Replicas Thereof”; and

Application Ser. No. 29/347,792, filed herewith and entitled “Decorative Element for a Vehicle”.

FIG. 1 is a left perspective view of a first embodiment of a decorative element for a vehicle according to my design;

FIG. 2 is a right perspective view thereof;

FIG. 3 is a top, left perspective view thereof;

FIG. 4 is a front view thereof;

FIG. 5 is a left side view thereof; and

FIG. 6 is a right side view thereof.

FIG. 7 is a right perspective view of a second embodiment of a decorative element for a vehicle according to my design;

FIG. 8 is a left perspective view thereof;

FIG. 9 is a top, right perspective view thereof;

FIG. 10 is a front view thereof;

FIG. 11 is a right side view thereof; and,

FIG. 12 is a left side view thereof.

The second embodiment is a mirror image of the left decorative element for a vehicle as shown in FIGS. 1-6.

In the drawings, the broken lines depict portions of the design that form no part of the claim.

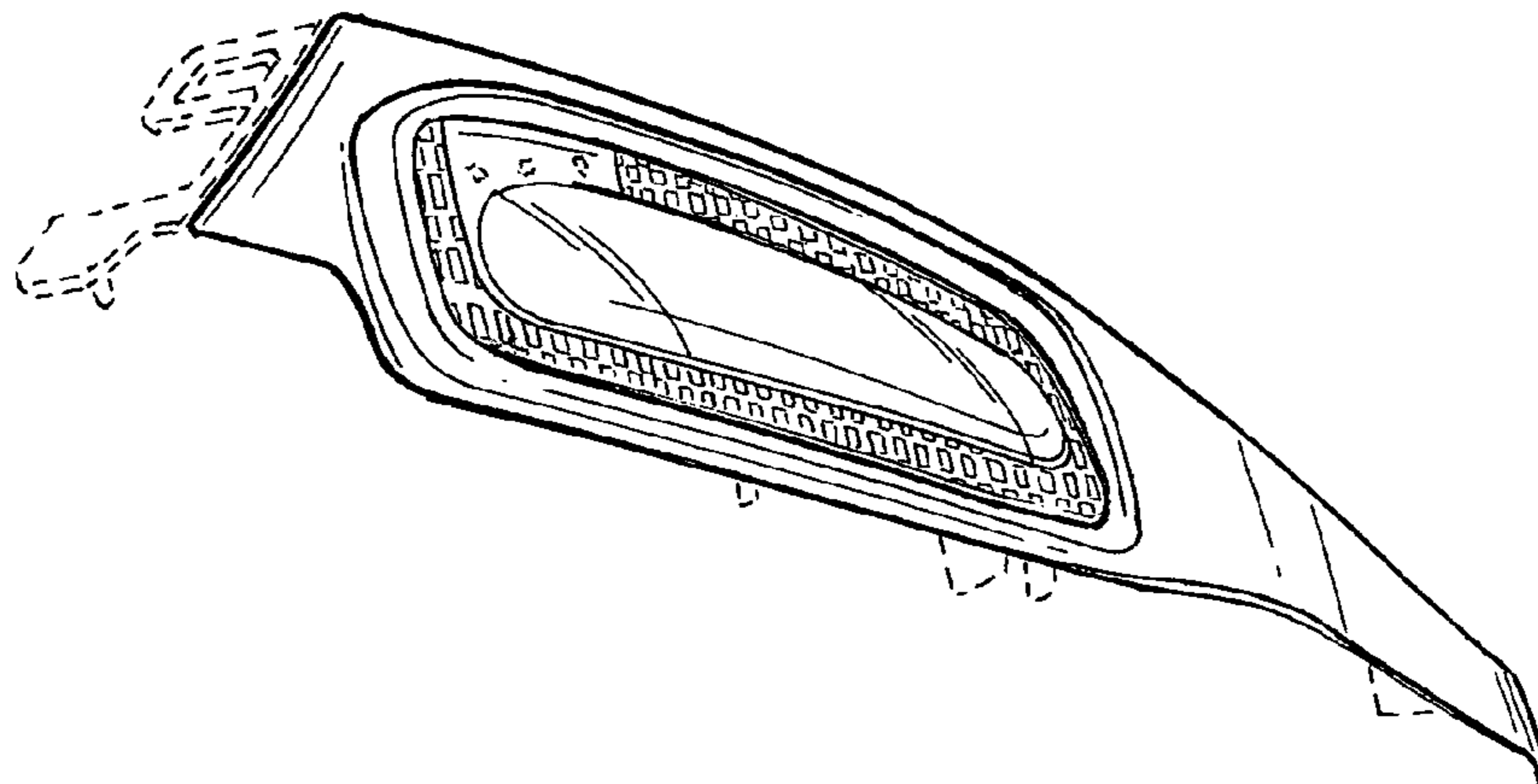

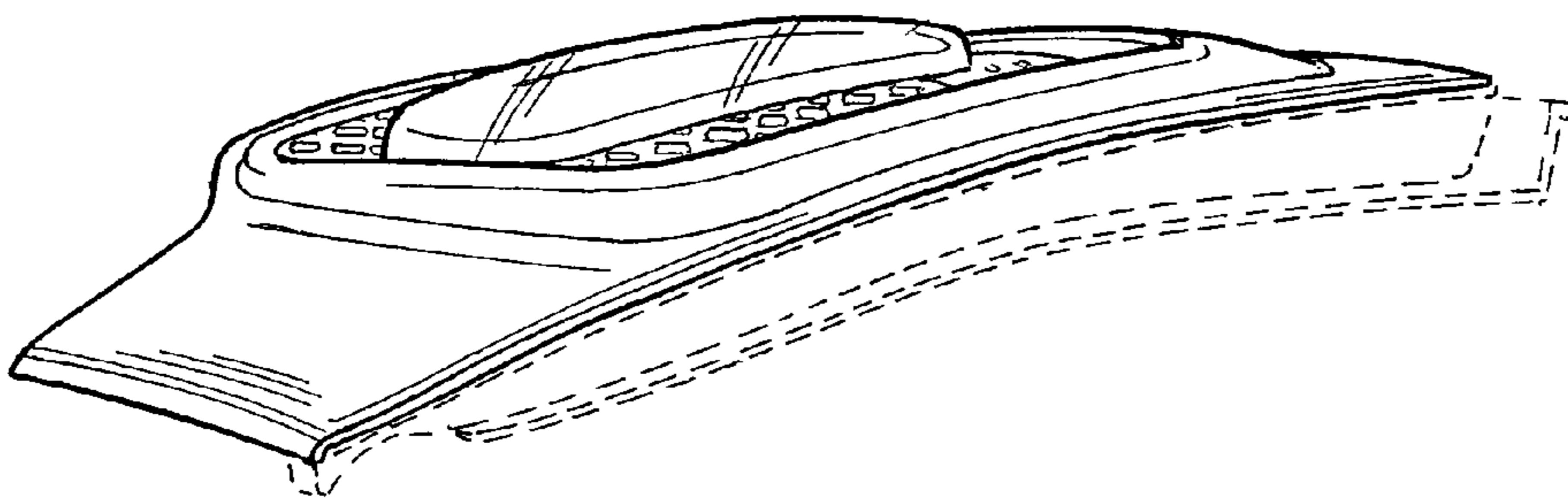

FIG. 3

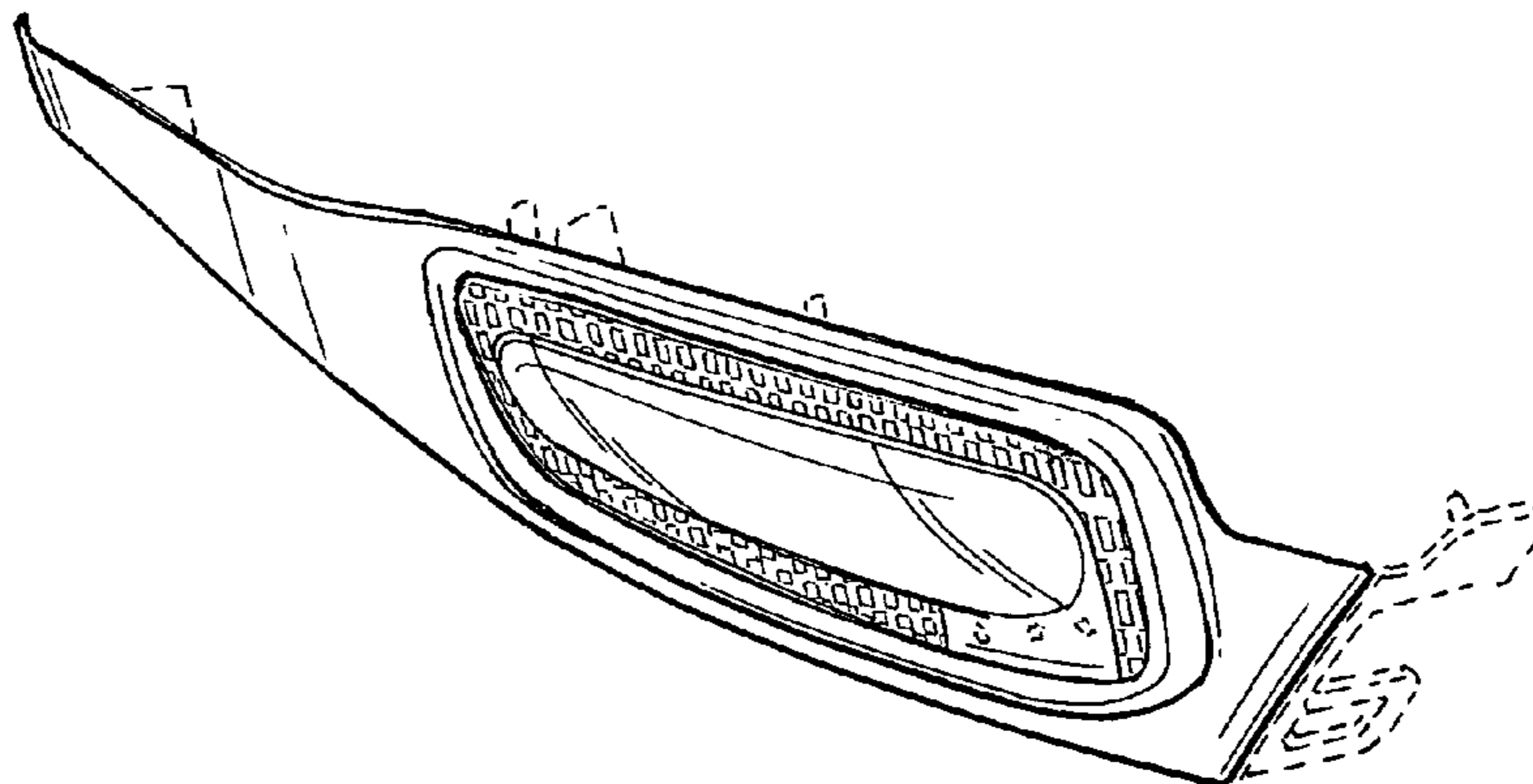

FIG. 2

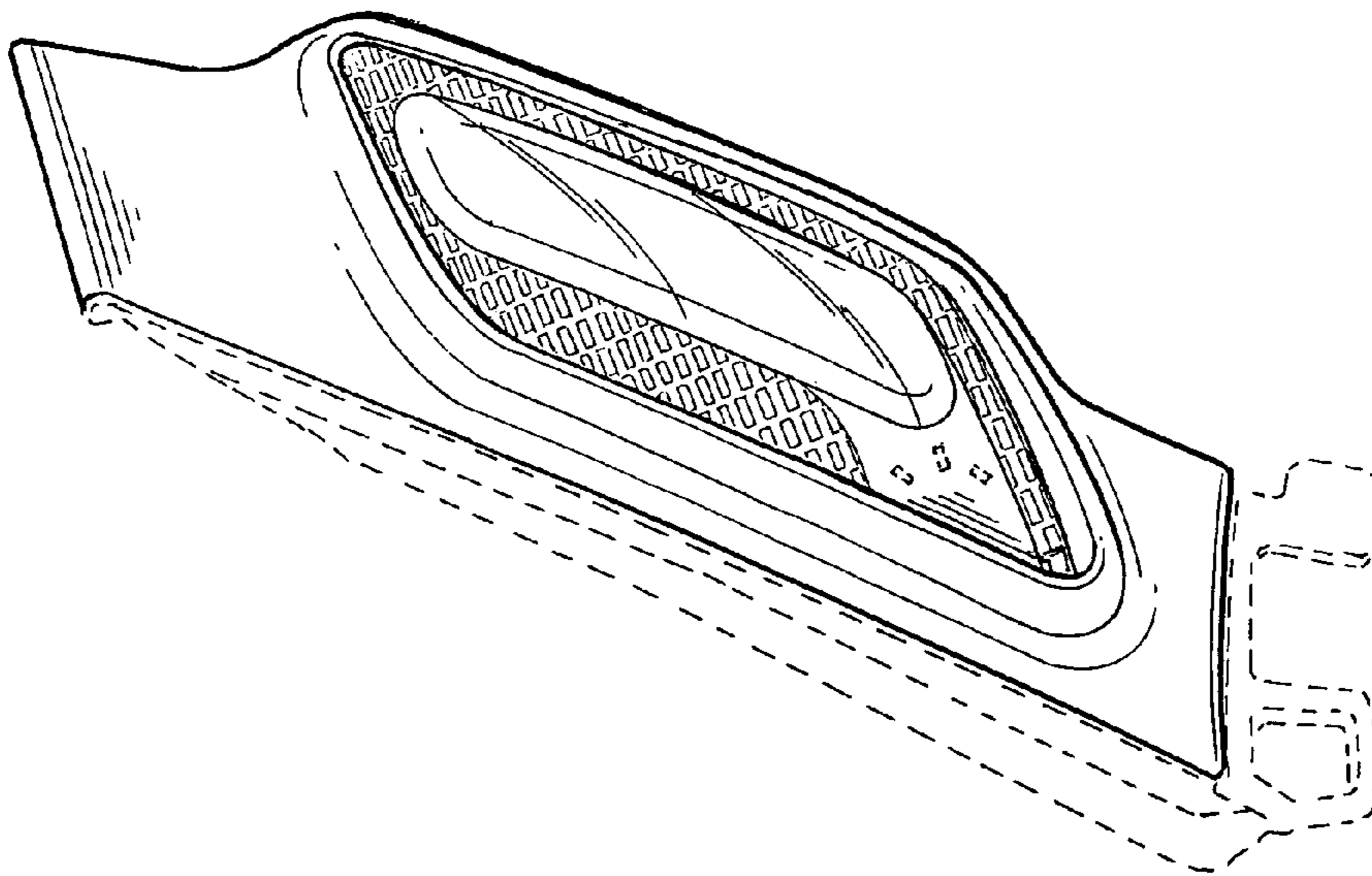

FIG. 1

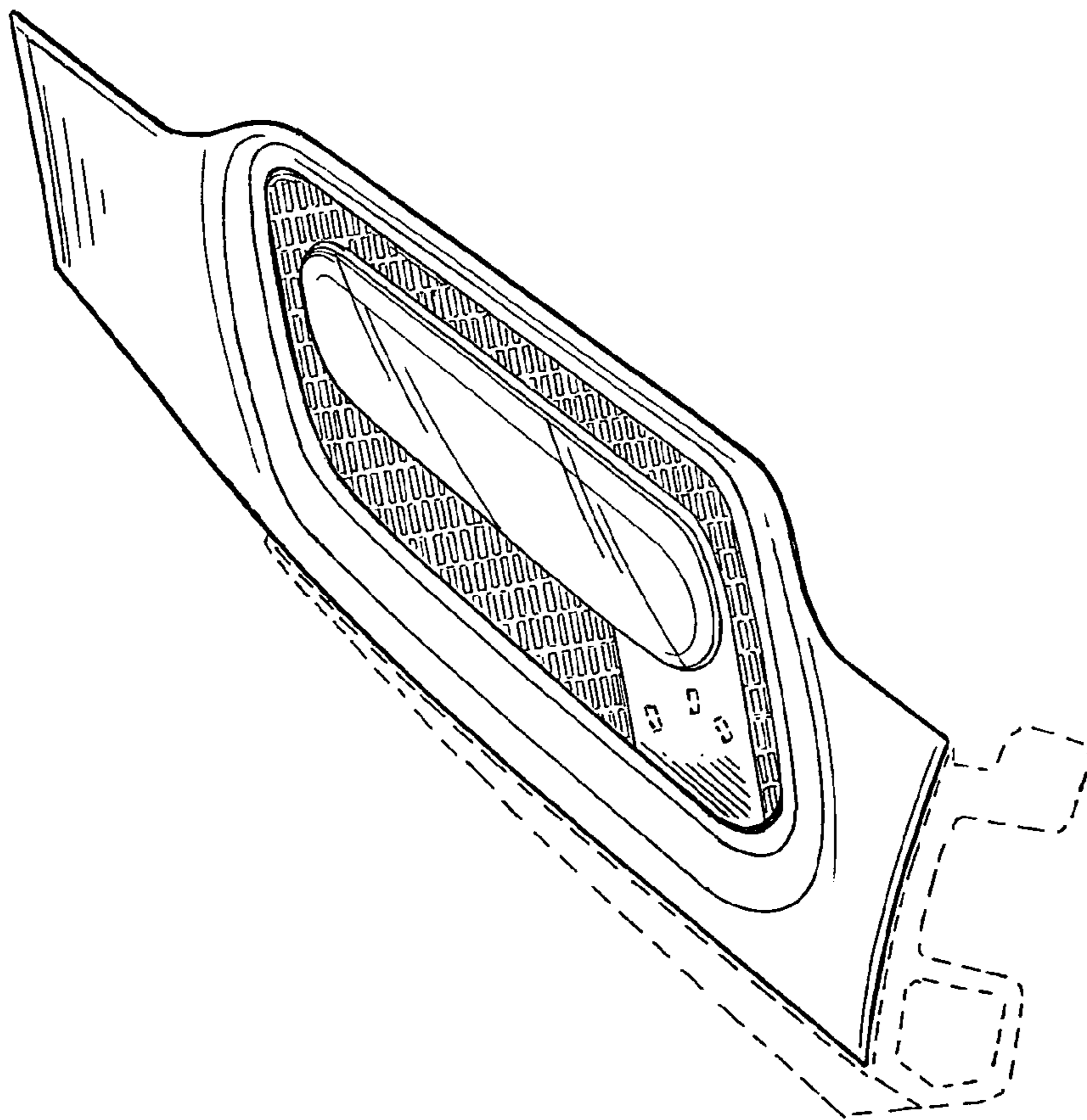

FIG. 4

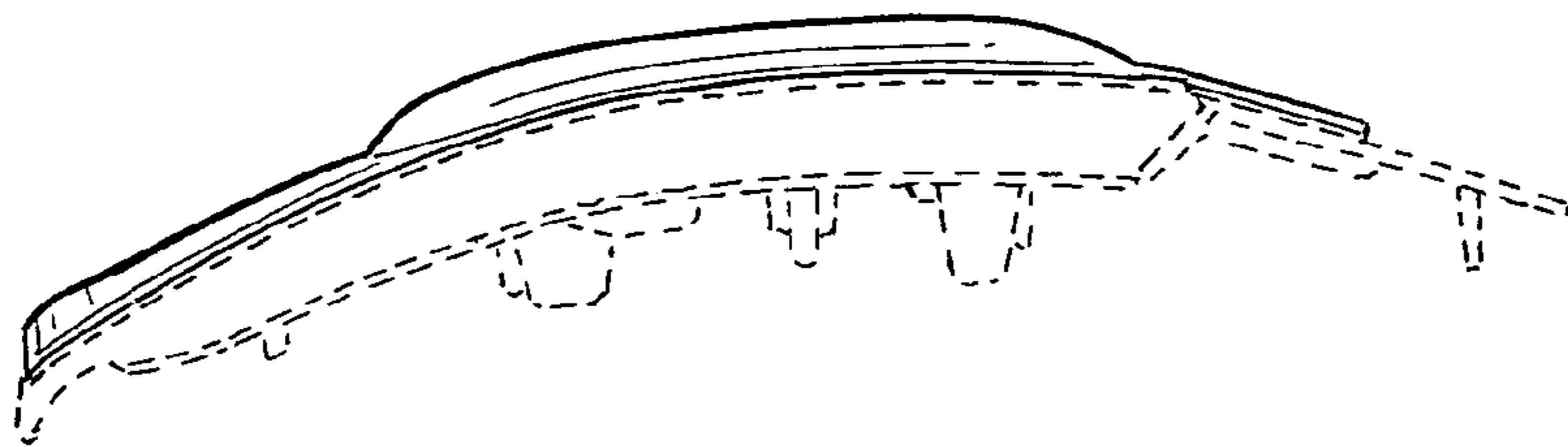

FIG. 5

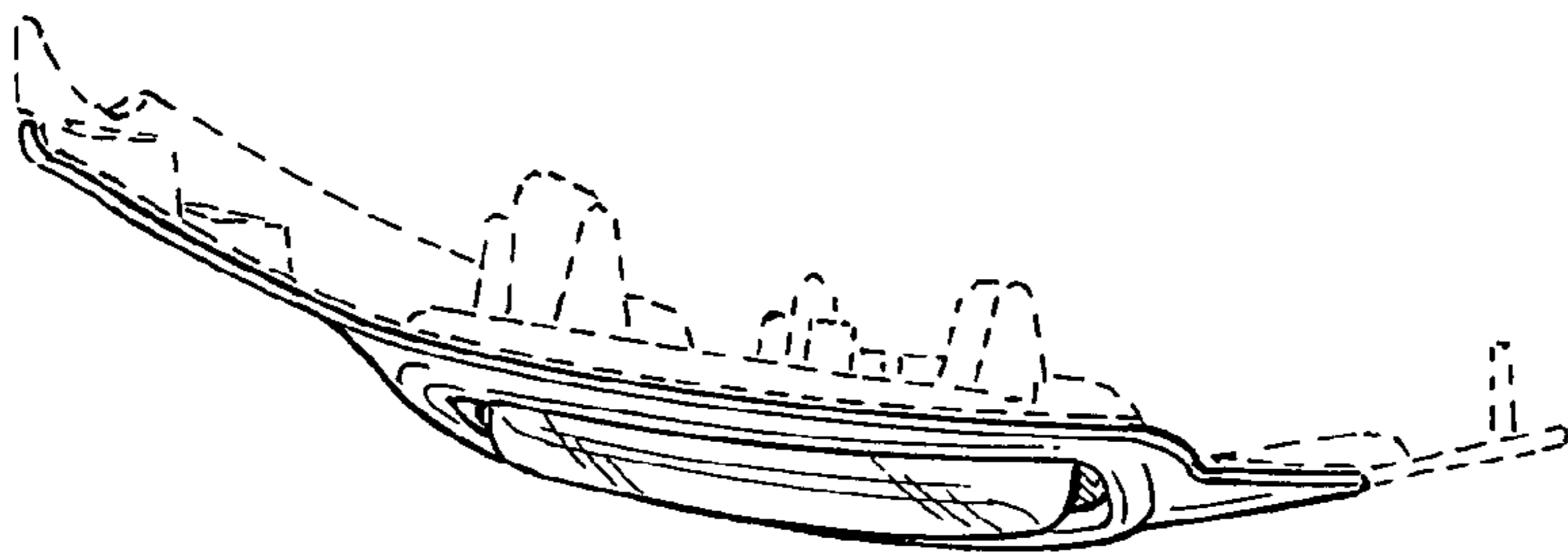

FIG. 6

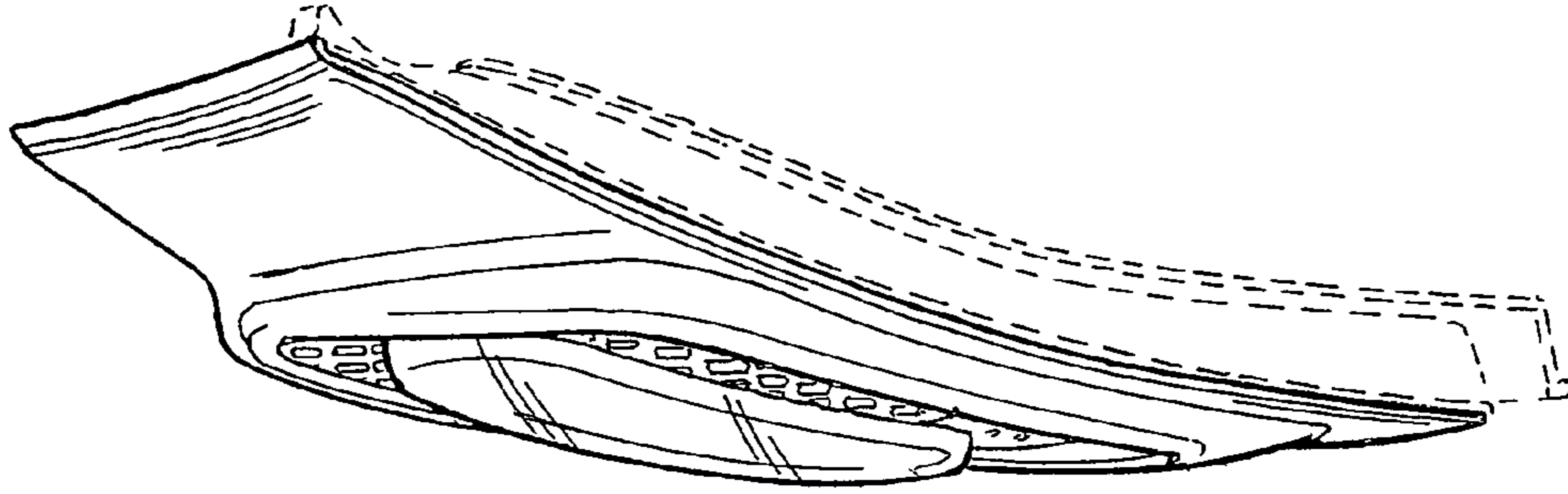

FIG. 9

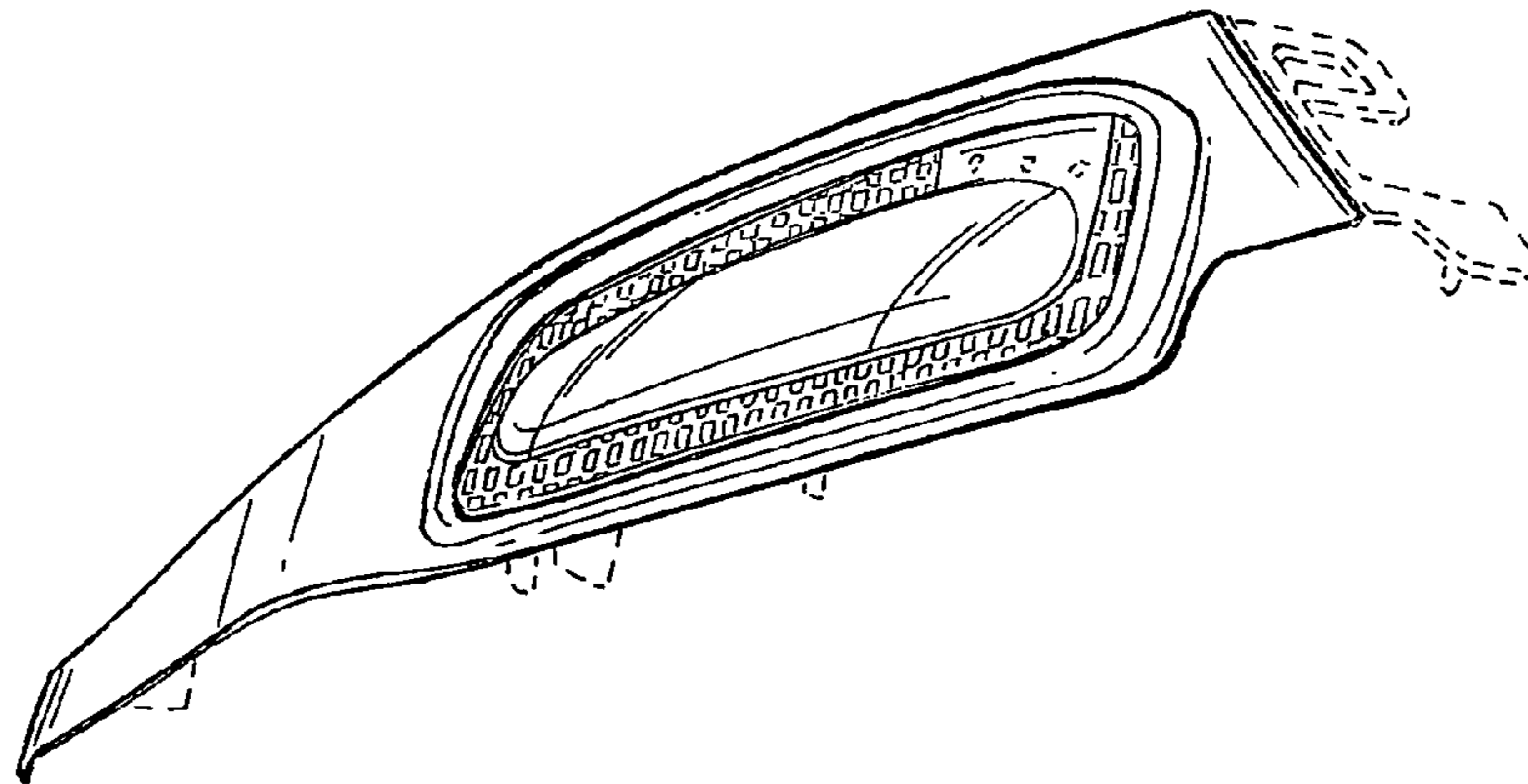

FIG. 8

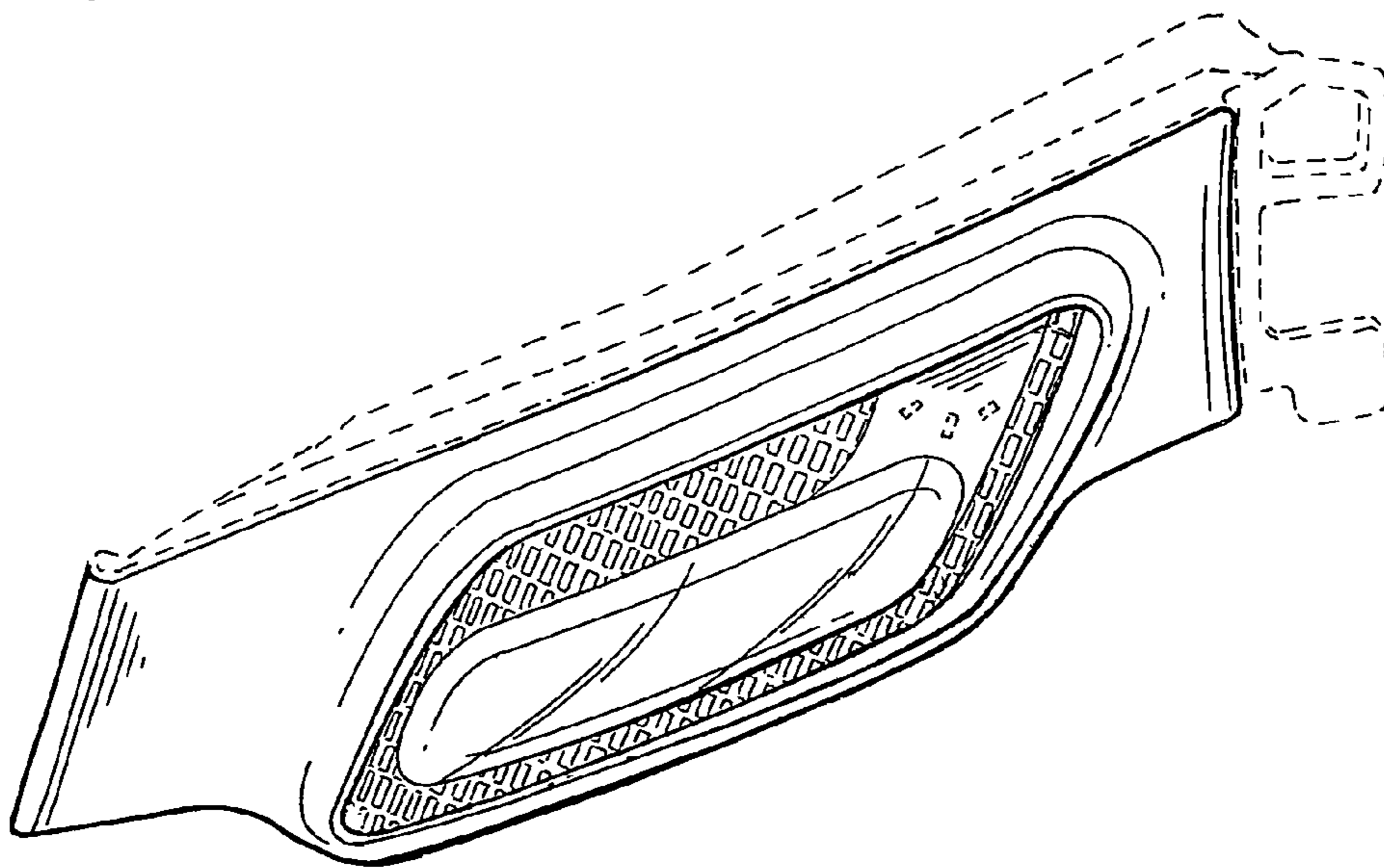

FIG. 7

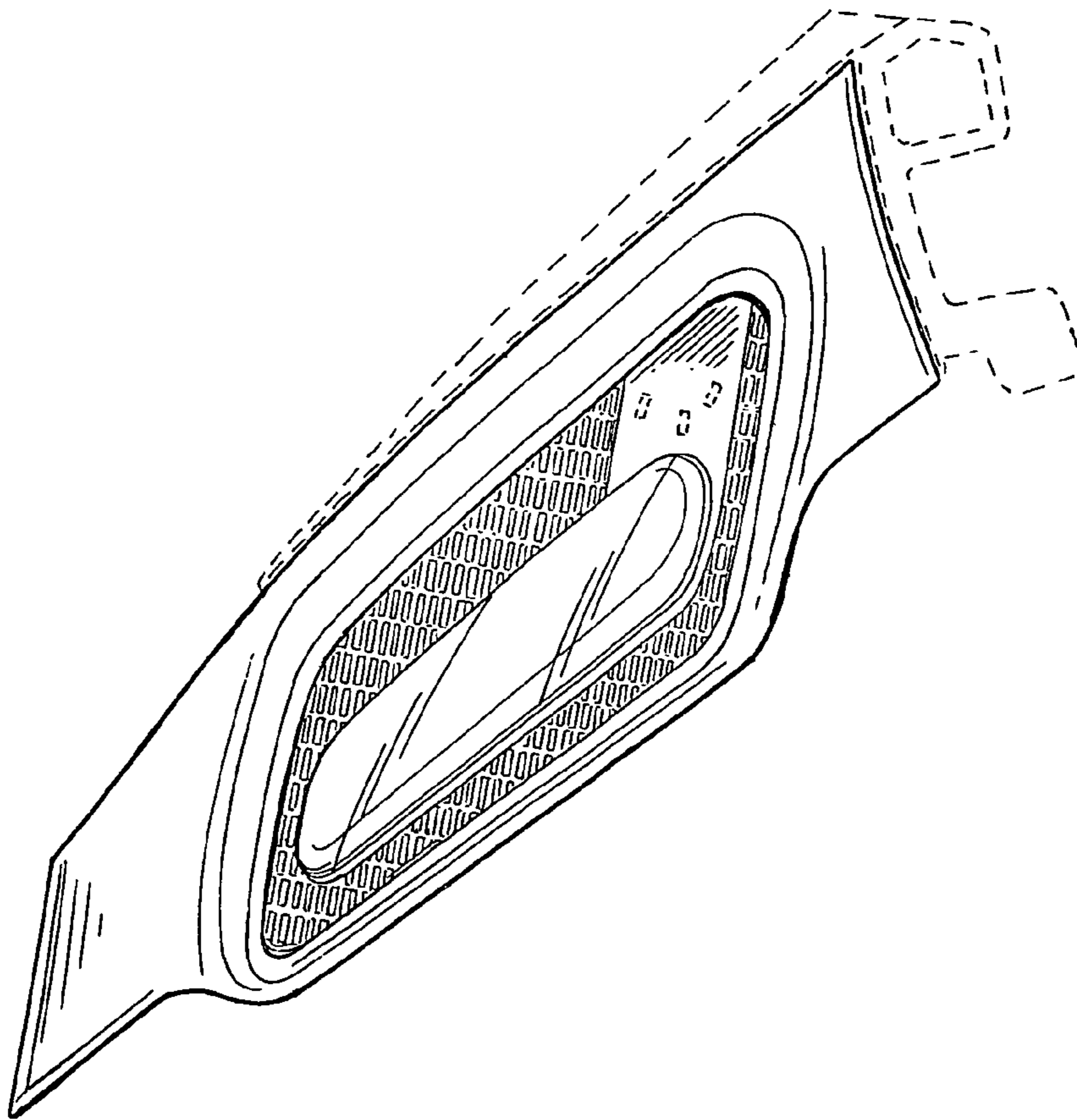

FIG. 10

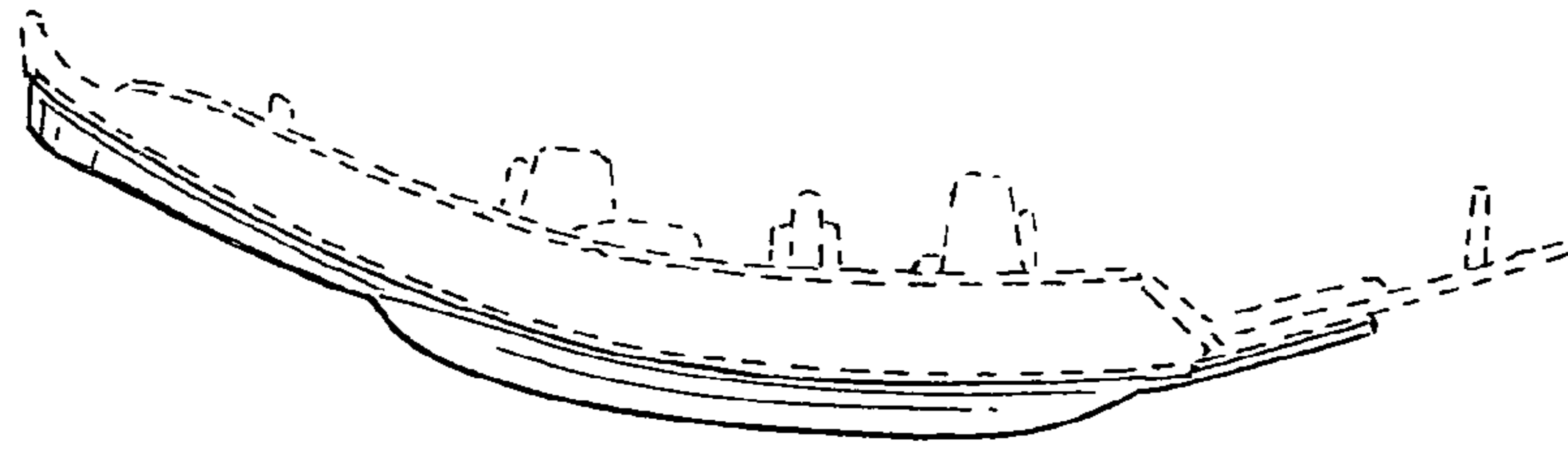

FIG. 11

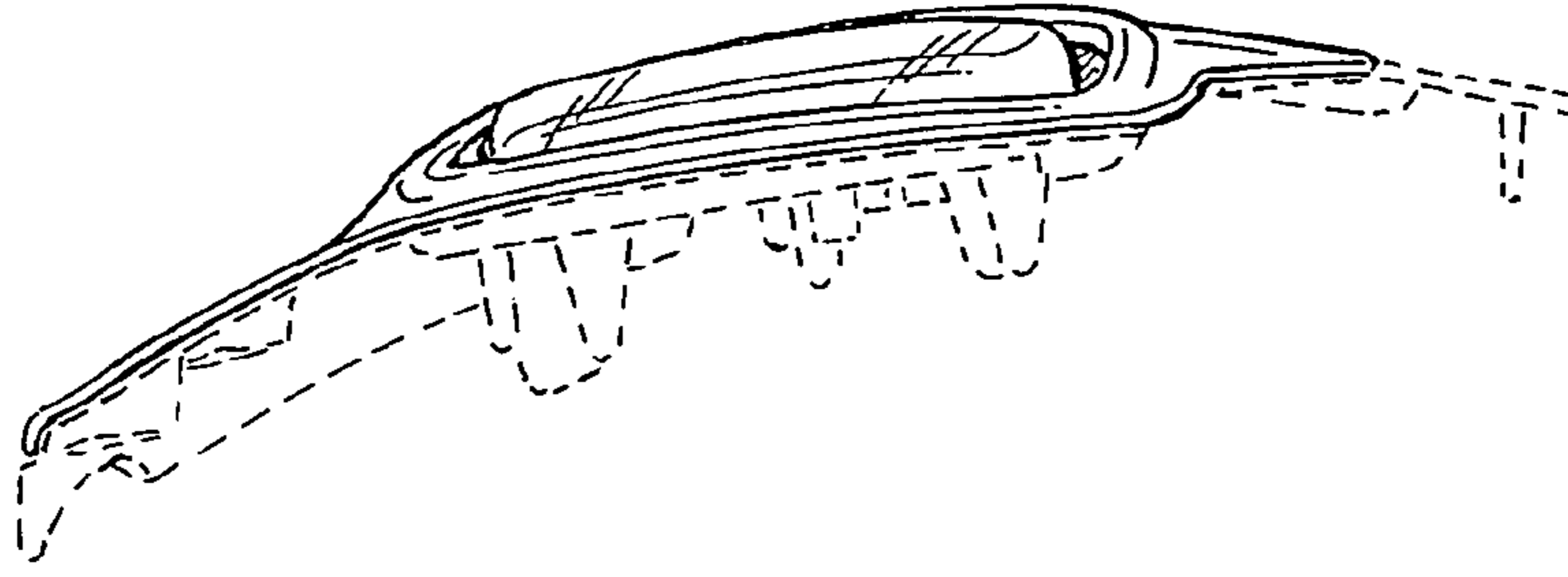

FIG. 12