



US00D631793S

(12) **United States Design Patent**  
**Sanschagrın**

(10) **Patent No.:** **US D631,793 S**  
(45) **Date of Patent:** **\*\* Feb. 1, 2011**

(54) **UTILITY VEHICLE SIDE FAIRING ASSEMBLY**

(75) Inventor: **Stephane Sanschagrın, Valcourt (CA)**

(73) Assignee: **Bombardier Recreational Products Inc., Valcourt (CA)**

(\*\*) Term: **14 Years**

(21) Appl. No.: **29/363,121**

(22) Filed: **Jun. 4, 2010**

(51) **LOC (9) Cl.** ..... **12-02**

(52) **U.S. Cl.** ..... **D12/14; D12/181**

(58) **Field of Classification Search** ..... D12/16,  
D12/173, 164, 196, 87, 86, 1, 433, 15, 107,  
D12/82, 88, 89, 90, 91, 92, 93, 167, 163,  
D12/169, 14, 181, 126; D15/30; D21/803;  
180/233, 908; 280/DIG. 5, 183, 184, 185,  
280/186, 28, 37.7

See application file for complete search history.

(56) **References Cited**

**U.S. PATENT DOCUMENTS**

D555,036 S *	11/2007	Eck	.....	D12/87
D586,694 S *	2/2009	Huang et al.	.....	D12/14
D588,957 S *	3/2009	Tuo	.....	D12/16
D606,900 S *	12/2009	Flores	.....	D12/87
D610,511 S *	2/2010	Dubanowski et al.	.....	D12/181
D610,514 S *	2/2010	Eck	.....	D12/196
D620,855 S *	8/2010	Waclawski et al.	.....	D12/181

\* cited by examiner

*Primary Examiner*—T. Chase Nelson

*Assistant Examiner*—Ania K Dworzecka

(74) *Attorney, Agent, or Firm*—Osler, Hoskin & Harcourt LLP

(57) **CLAIM**

The ornamental design for a utility vehicle side fairing assembly, as shown and described.

**DESCRIPTION**

FIG. 1 is a perspective view taken from a front, left side of a utility vehicle side fairing assembly according to my design;

FIG. 2 is a perspective view taken from a rear, left side thereof;

FIG. 3 is a perspective view taken from a front, right side thereof;

FIG. 4 is a perspective view taken from a rear, right side thereof;

FIG. 5 is a front elevation view thereof, with the two front wheels shown in dotted lines in the other Figures removed for clarity;

FIG. 6 is a right side elevation view thereof;

FIG. 7 is a left side elevation view thereof;

FIG. 8 is a rear elevation view thereof, with the two rear wheels shown in dotted lines in the other Figures removed for clarity;

FIG. 9 is a top plan view thereof; and,

FIG. 10 is a bottom plan view thereof, with the wheels shown in dotted lines in the other Figures removed for clarity.

Throughout the Figures, the broken lines showing additional structure of the utility vehicle side fairing assembly and the utility vehicle on which it is shown are for illustrative purposes only and form no part of the claimed design. Portions of the utility vehicle side fairing assembly not shown in the Figures and not otherwise described in this Specification do not form part of the claimed design.

Throughout the Figures, the unshaded surfaces do not form part of the claimed design.

**1 Claim, 10 Drawing Sheets**

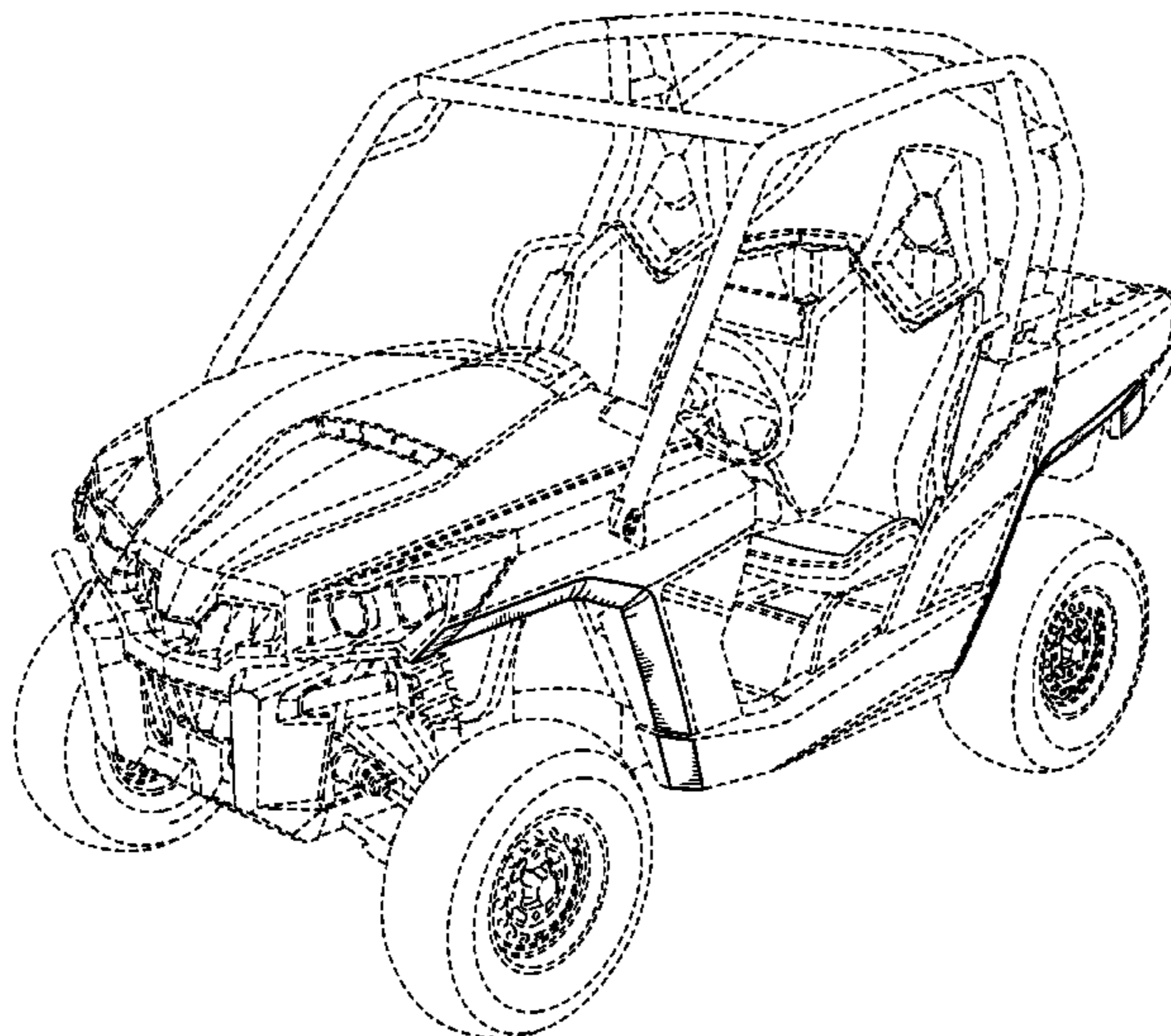

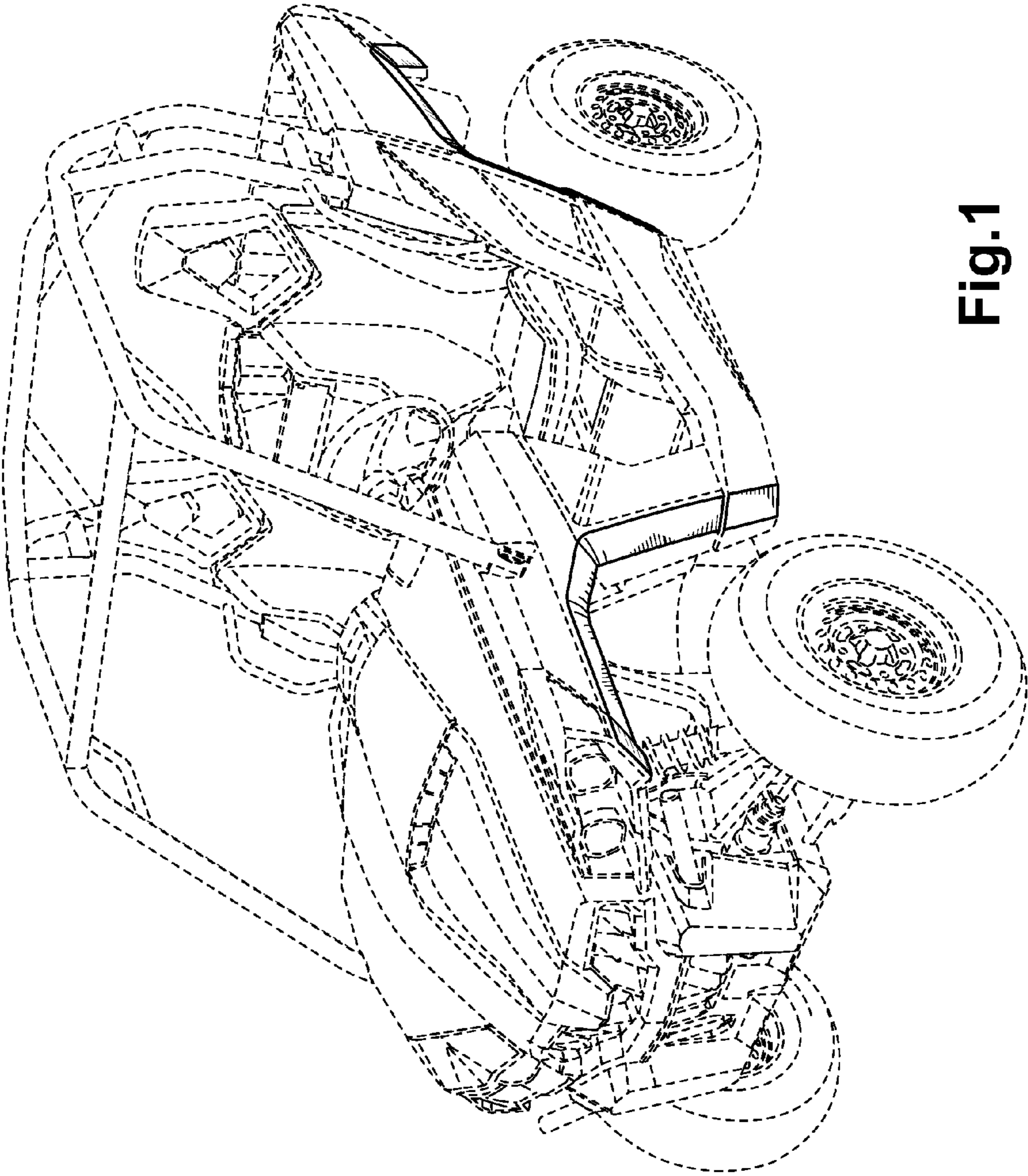

Fig.1

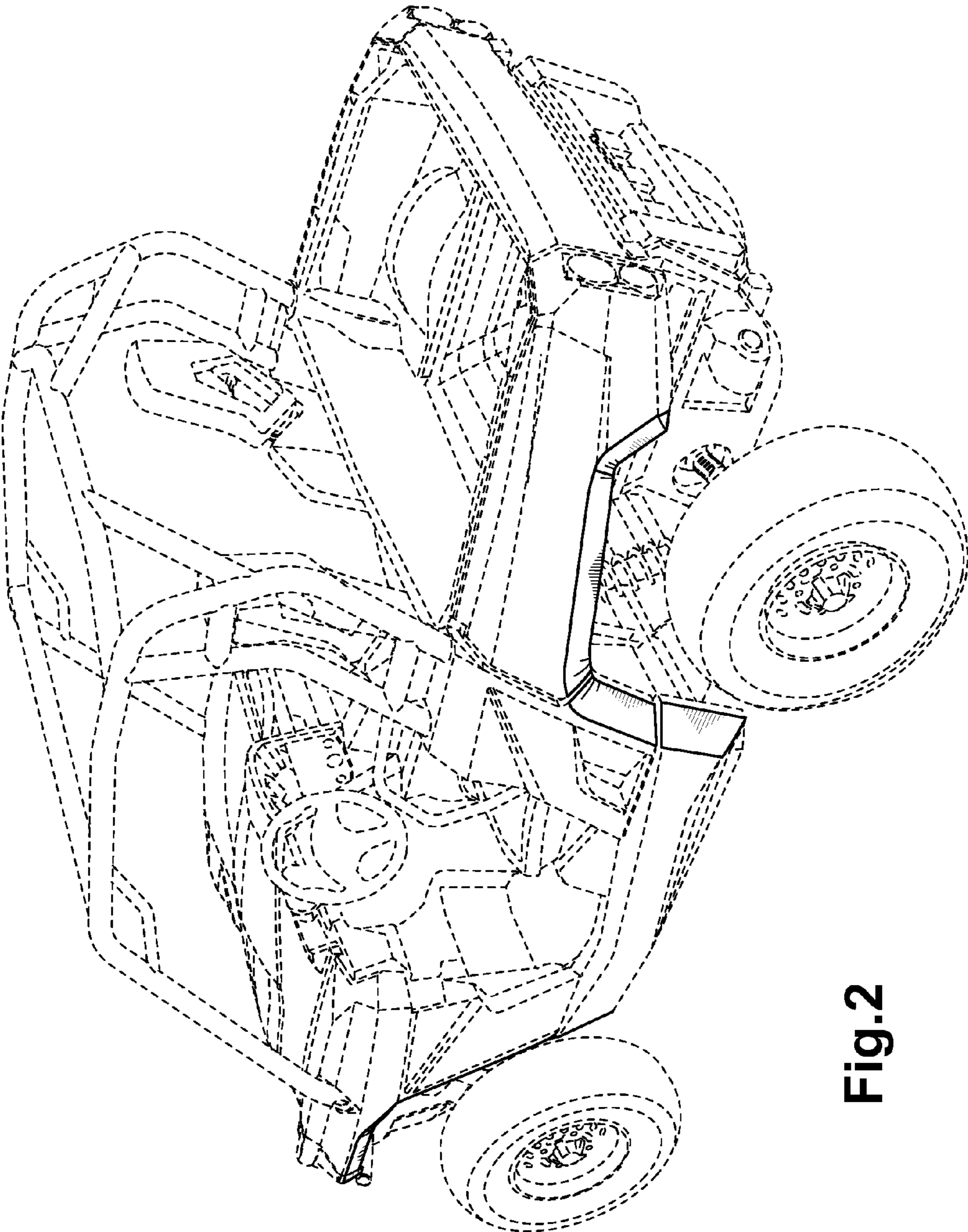

Fig.2

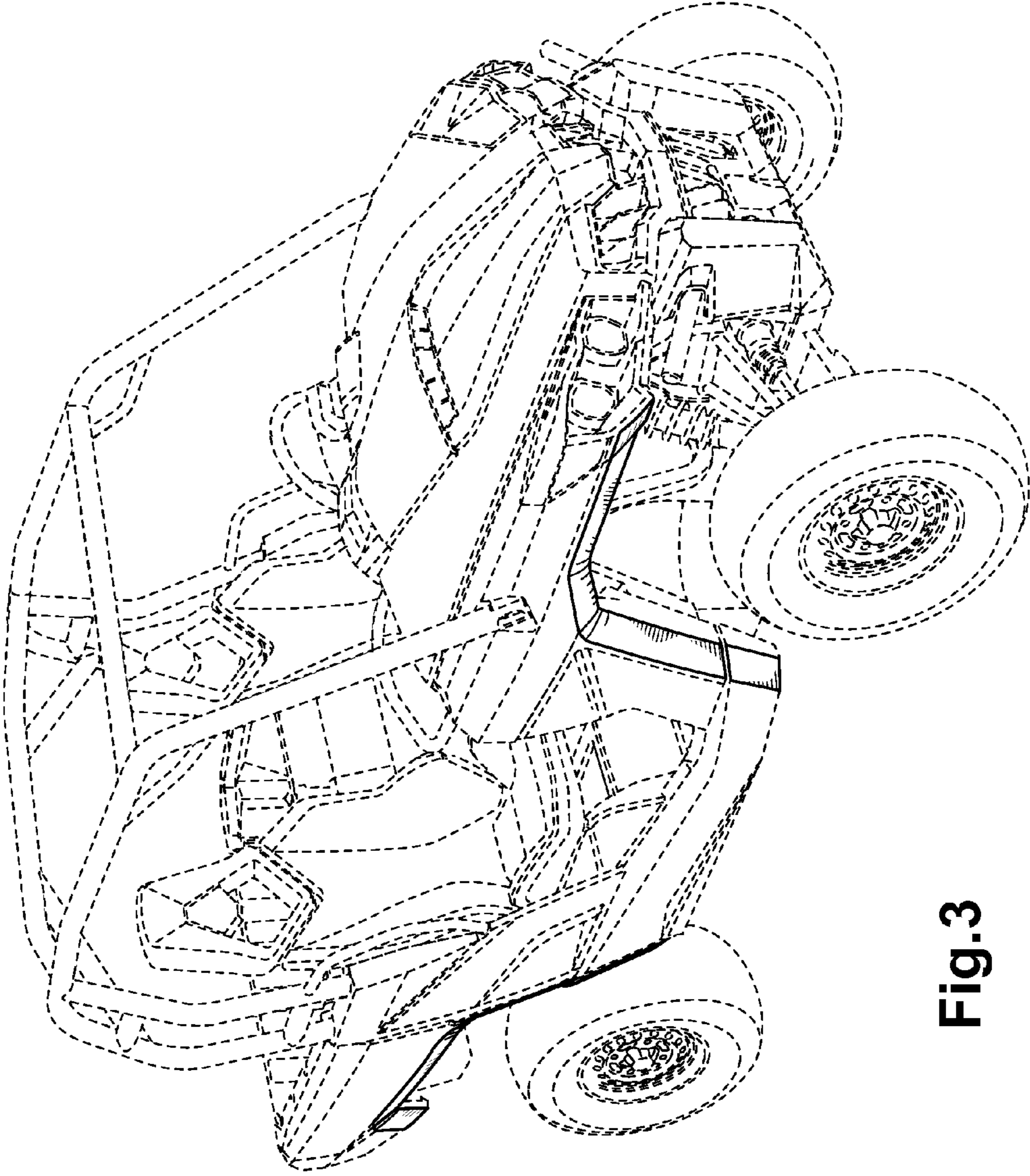

Fig.3

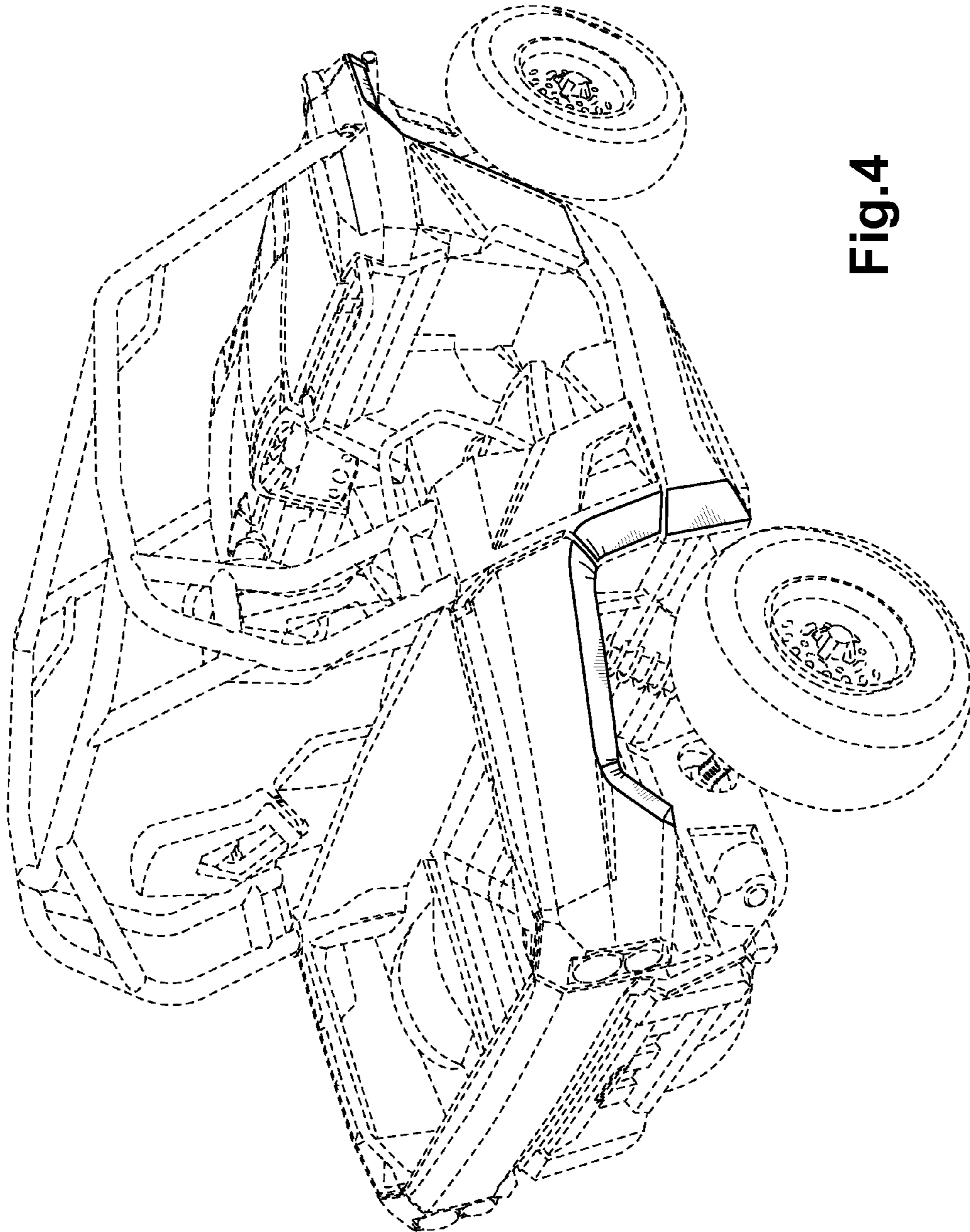
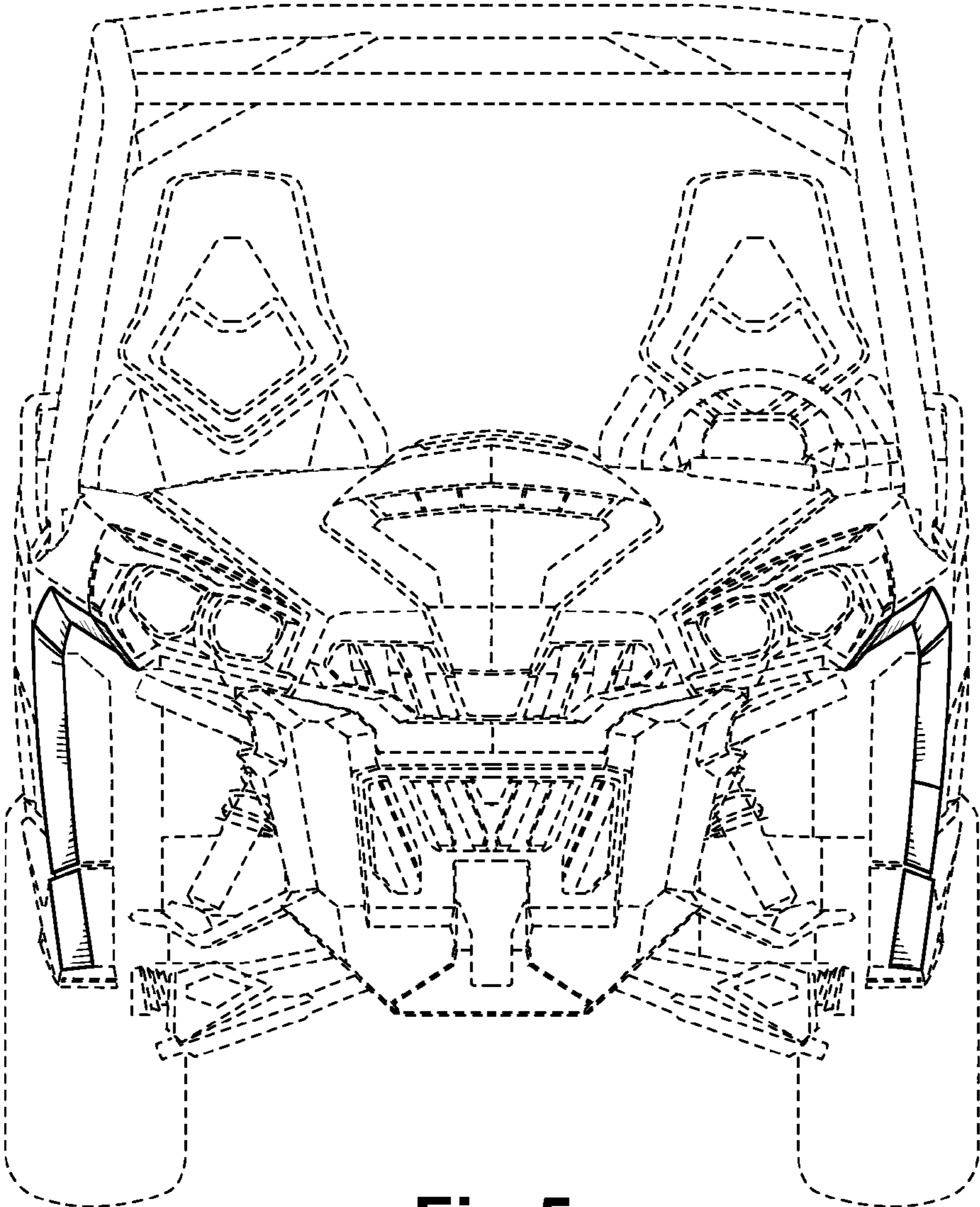

Fig.4



**Fig.5**

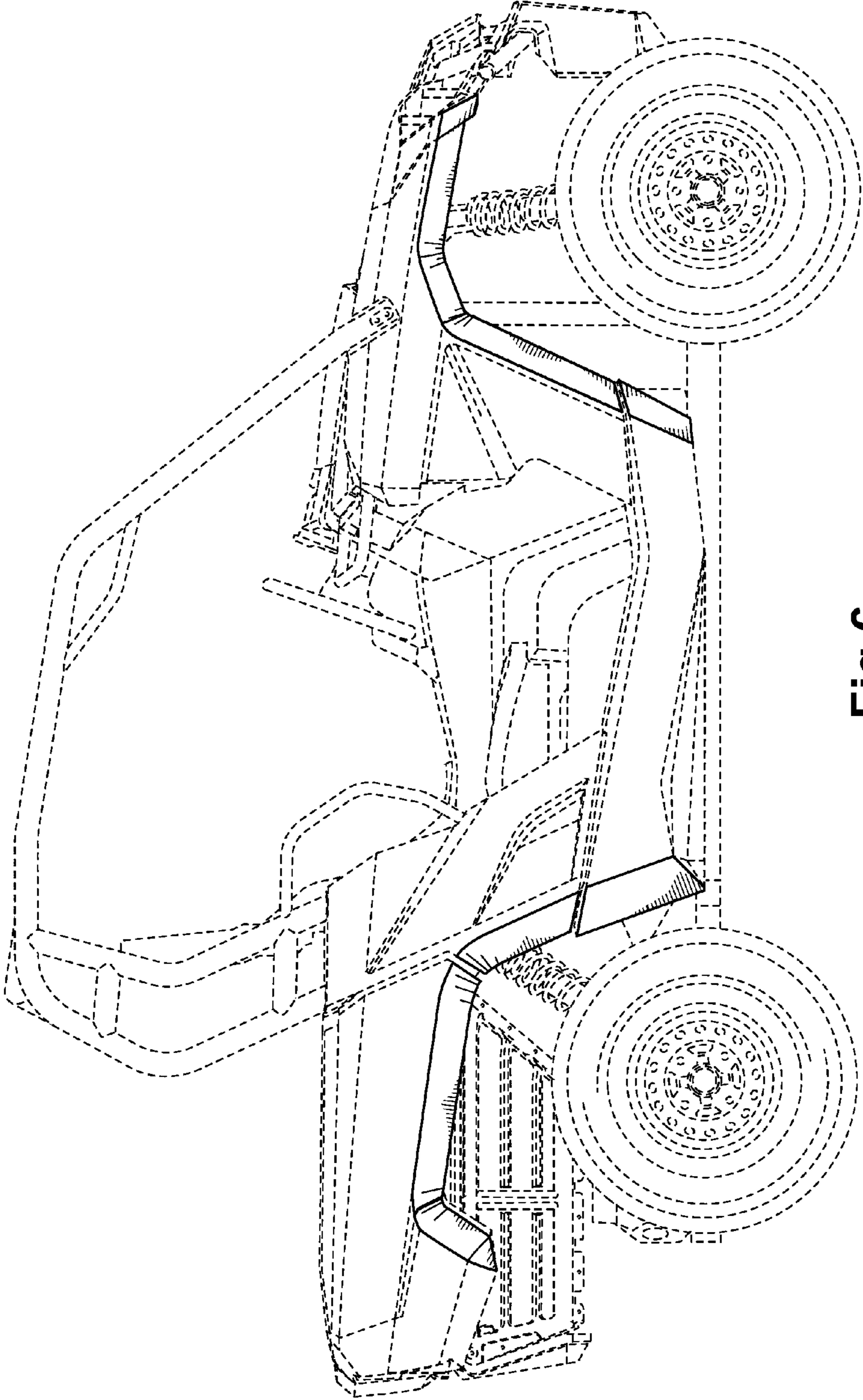

Fig.6

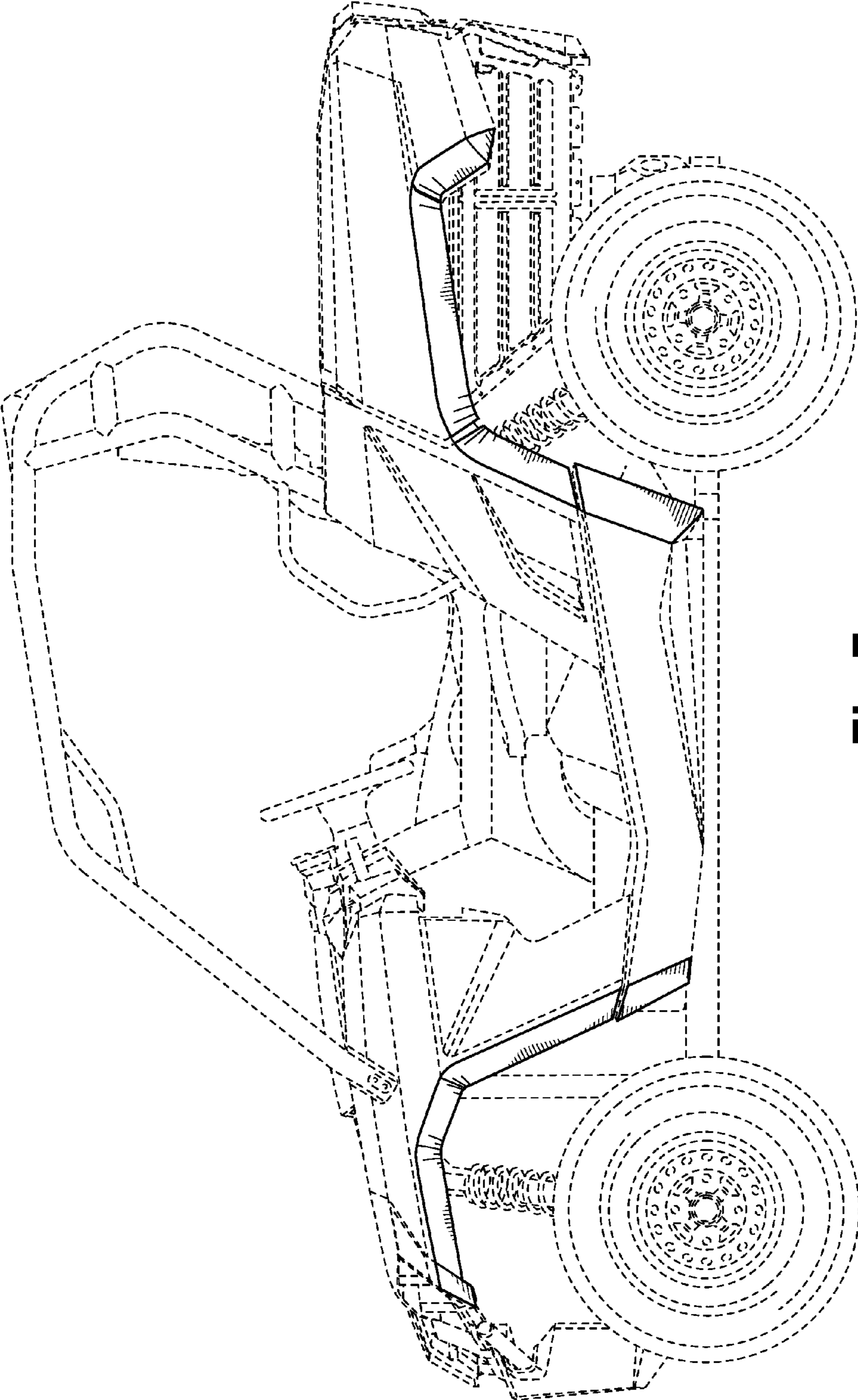

Fig.7



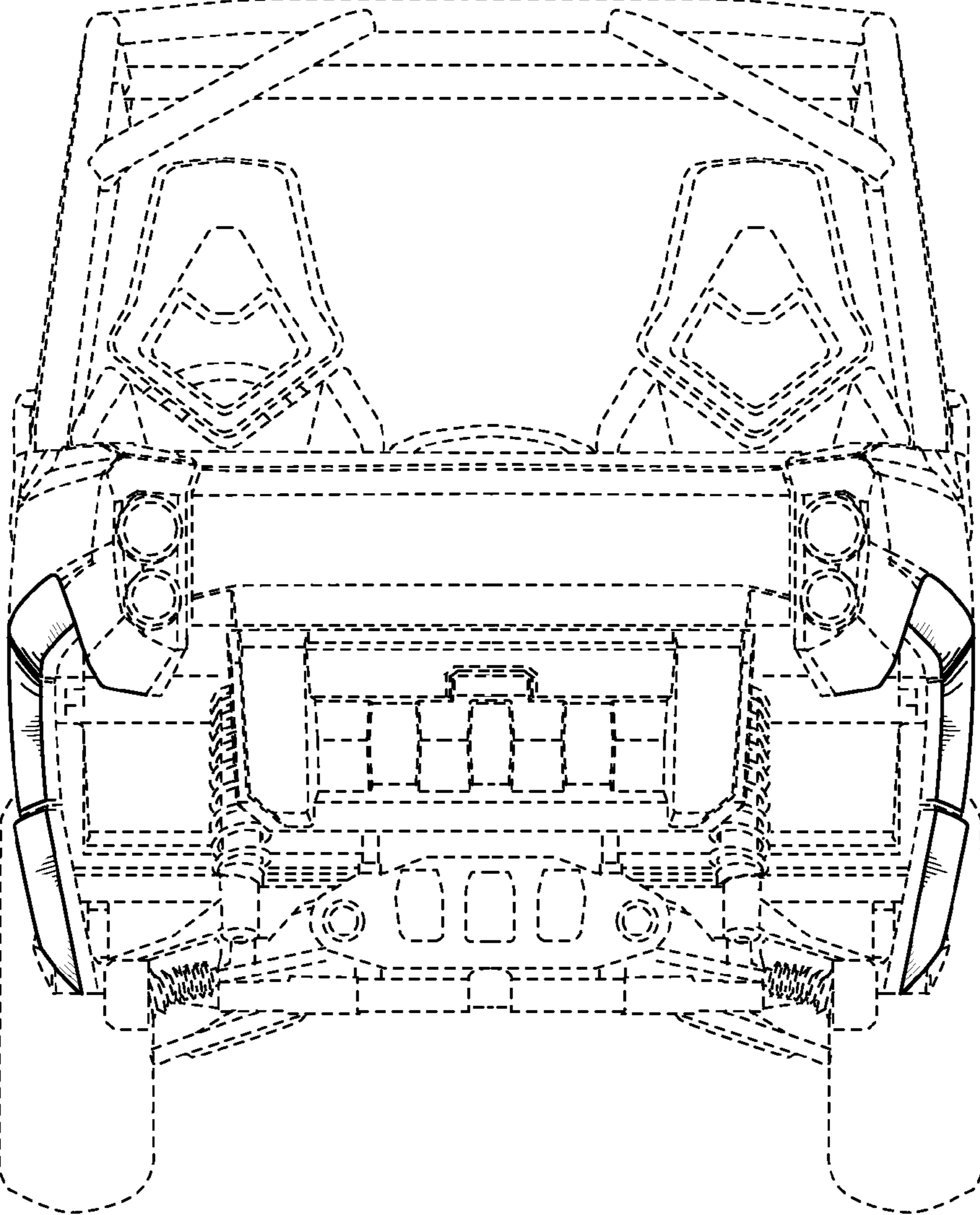

Fig.8

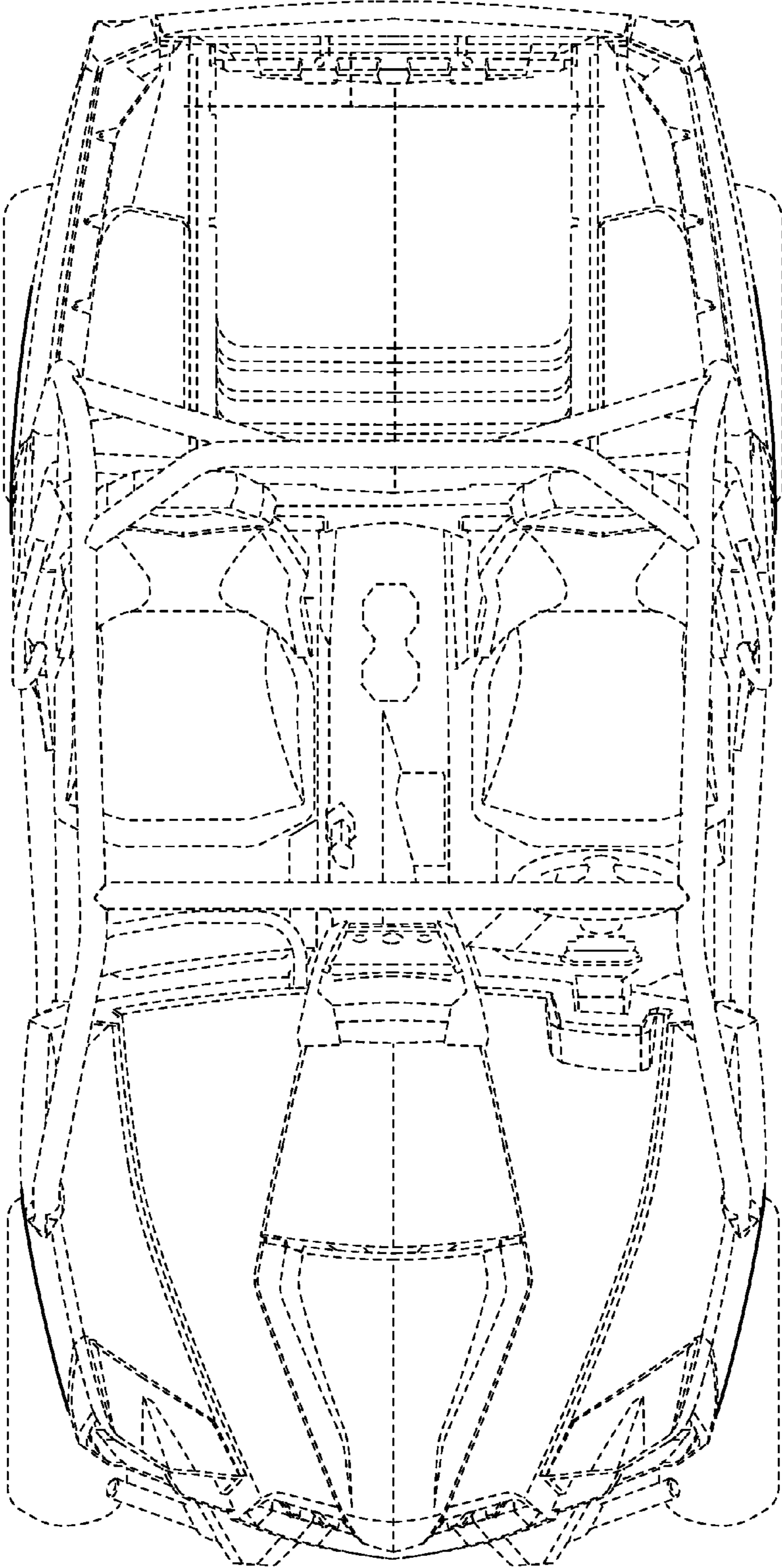

Fig.9

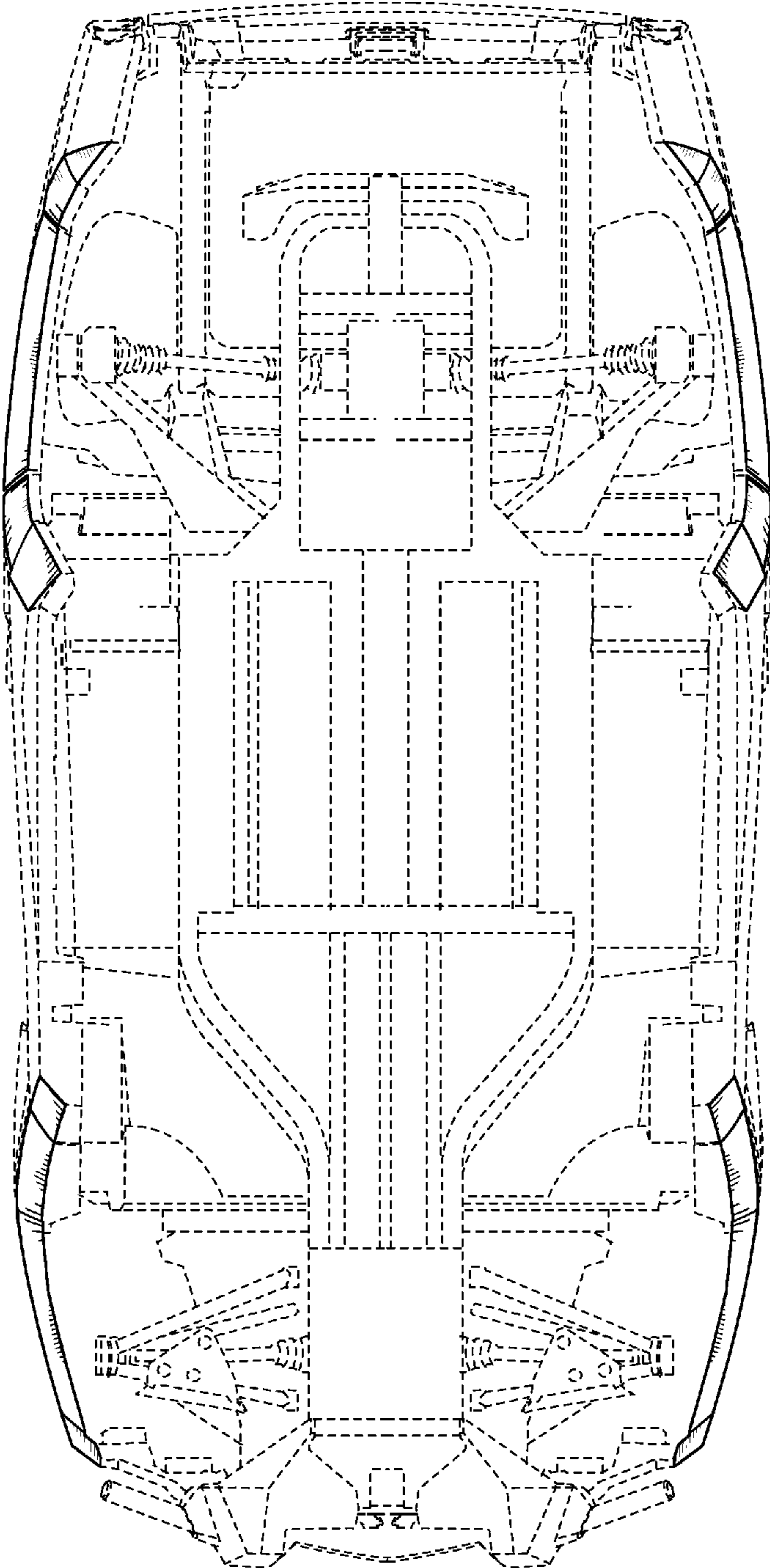

Fig.10