



US00D631621S

(12) **United States Design Patent**  
**Lee et al.**

(10) **Patent No.:** **US D631,621 S**  
(45) **Date of Patent:** **\*\* Jan. 25, 2011**

(54) **DRUM-TYPE WASHING MACHINE**

(75) Inventors: **Sung kyung Lee**, Kyungki-do (KR);  
**Dong won Chun**, Kyungki-do (KR)

(73) Assignee: **Samsung Electronics Co., Ltd.**, Suwon (KR)

(\*\*) Term: **14 Years**

(21) Appl. No.: **29/354,833**

(22) Filed: **Jan. 29, 2010**

(51) **LOC (9) Cl.** ..... **15-05**

(52) **U.S. Cl.** ..... **D32/6**

(58) **Field of Classification Search** ..... D32/1,  
D32/5-6, 8; 68/3 R, 5 R, 12.01, 12.08; 34/87-88,  
34/524, 534; 312/31

See application file for complete search history.

(56) **References Cited**

**U.S. PATENT DOCUMENTS**

D496,709 S *	9/2004	Suh et al.	.....	D32/6
D517,257 S *	3/2006	Kim et al.	.....	D32/6
D517,756 S *	3/2006	Ha et al.	.....	D32/6
D549,896 S *	8/2007	Suh	.....	D32/6
D549,897 S *	8/2007	Suh	.....	D32/6
D572,419 S *	7/2008	Park et al.	.....	D32/6

D576,362 S *	9/2008	Park et al.	.....	D32/6
D577,161 S *	9/2008	Jeon et al.	.....	D32/6
D582,105 S *	12/2008	Cho et al.	.....	D32/6
D589,661 S *	3/2009	Oh et al.	.....	D32/6

\* cited by examiner

*Primary Examiner*—T. Chase Nelson

*Assistant Examiner*—Kathleen M Sims

(74) *Attorney, Agent, or Firm*—Ladas & Parry LLP

(57) **CLAIM**

We claim the ornamental design for drum-type washing machine, as shown.

**DESCRIPTION**

FIG. 1 is a front/right-side/top perspective view of a drum-type washing machine showing our new design;

FIG. 2 is a front-side elevational view thereof;

FIG. 3 is a rear-side elevational view thereof;

FIG. 4 is a left-side elevational view thereof;

FIG. 5 is a right-side elevational view thereof;

FIG. 6 is a top-side elevational view thereof; and,

FIG. 7 is a bottom-side elevational view thereof.

**1 Claim, 7 Drawing Sheets**

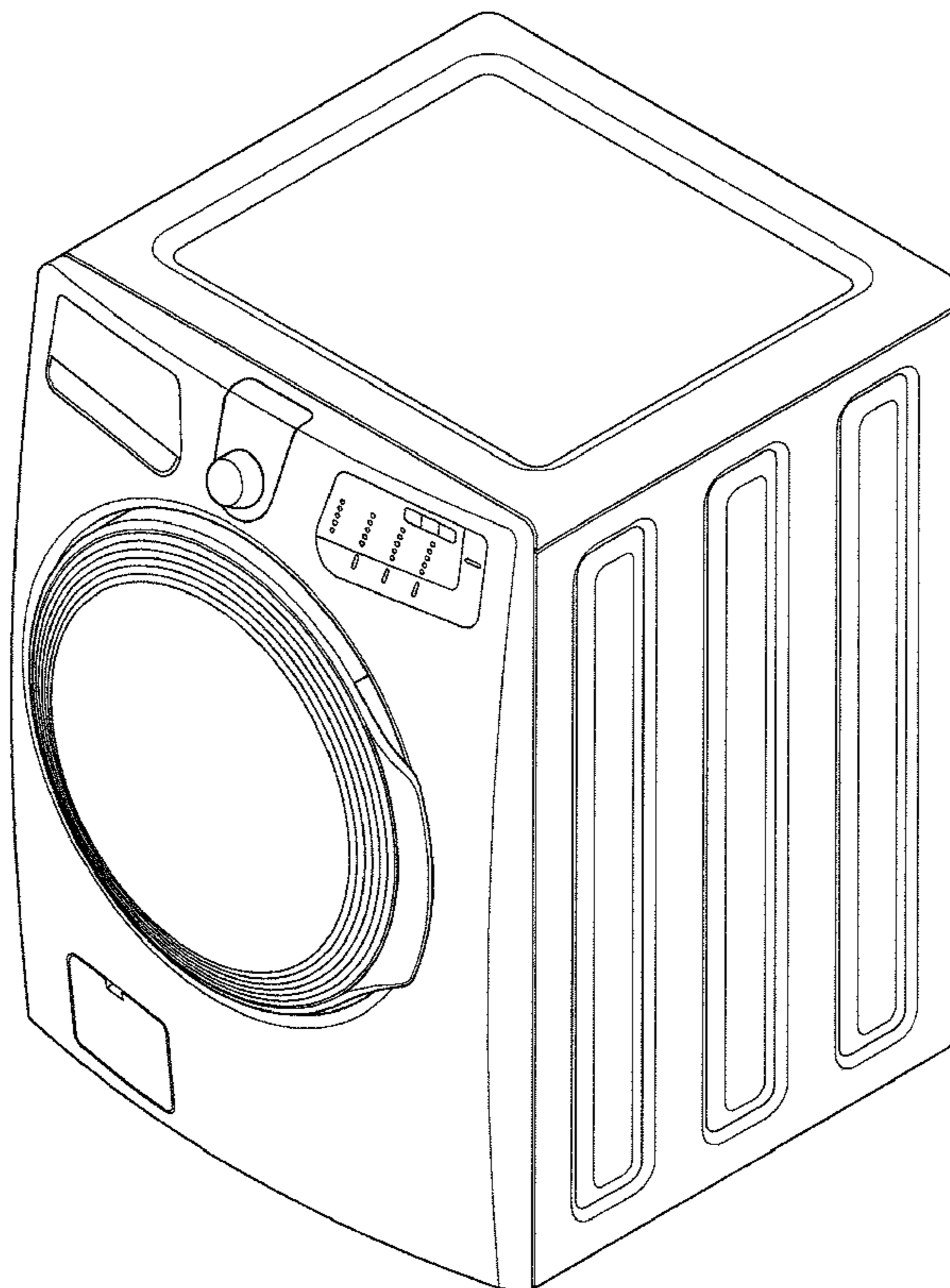
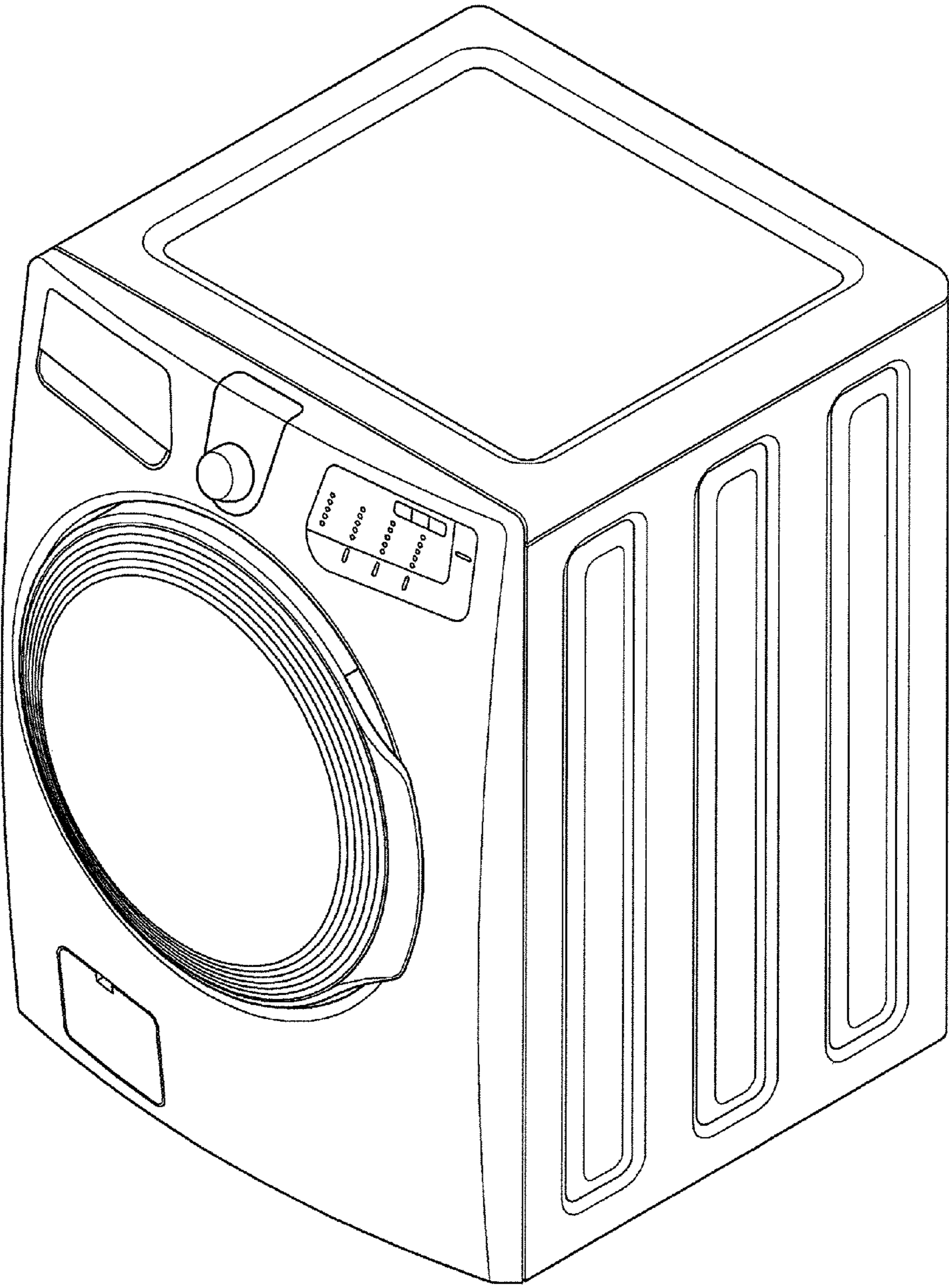
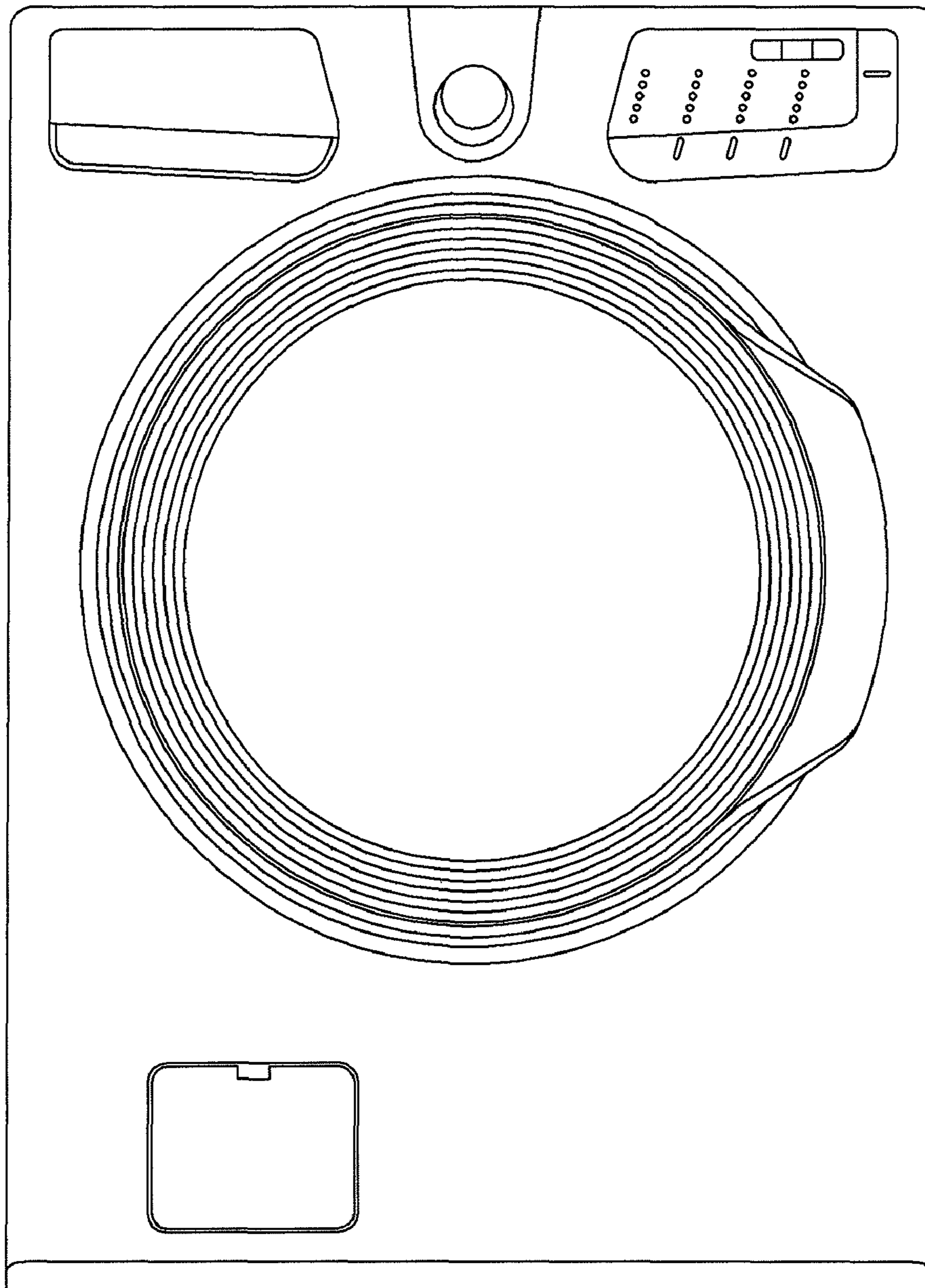

FIG. 1



**FIG. 2**



**FIG. 3**

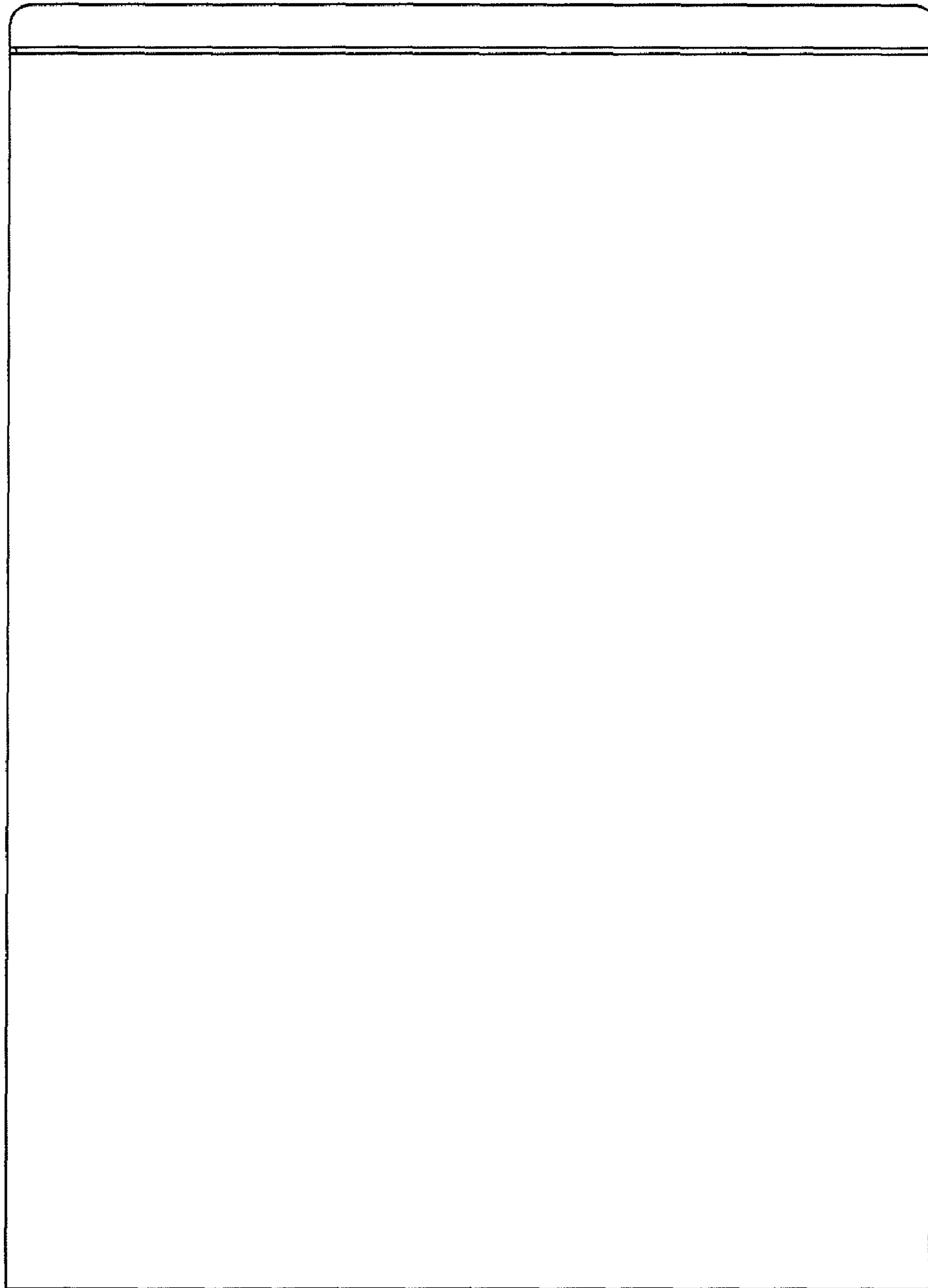

**FIG. 4**

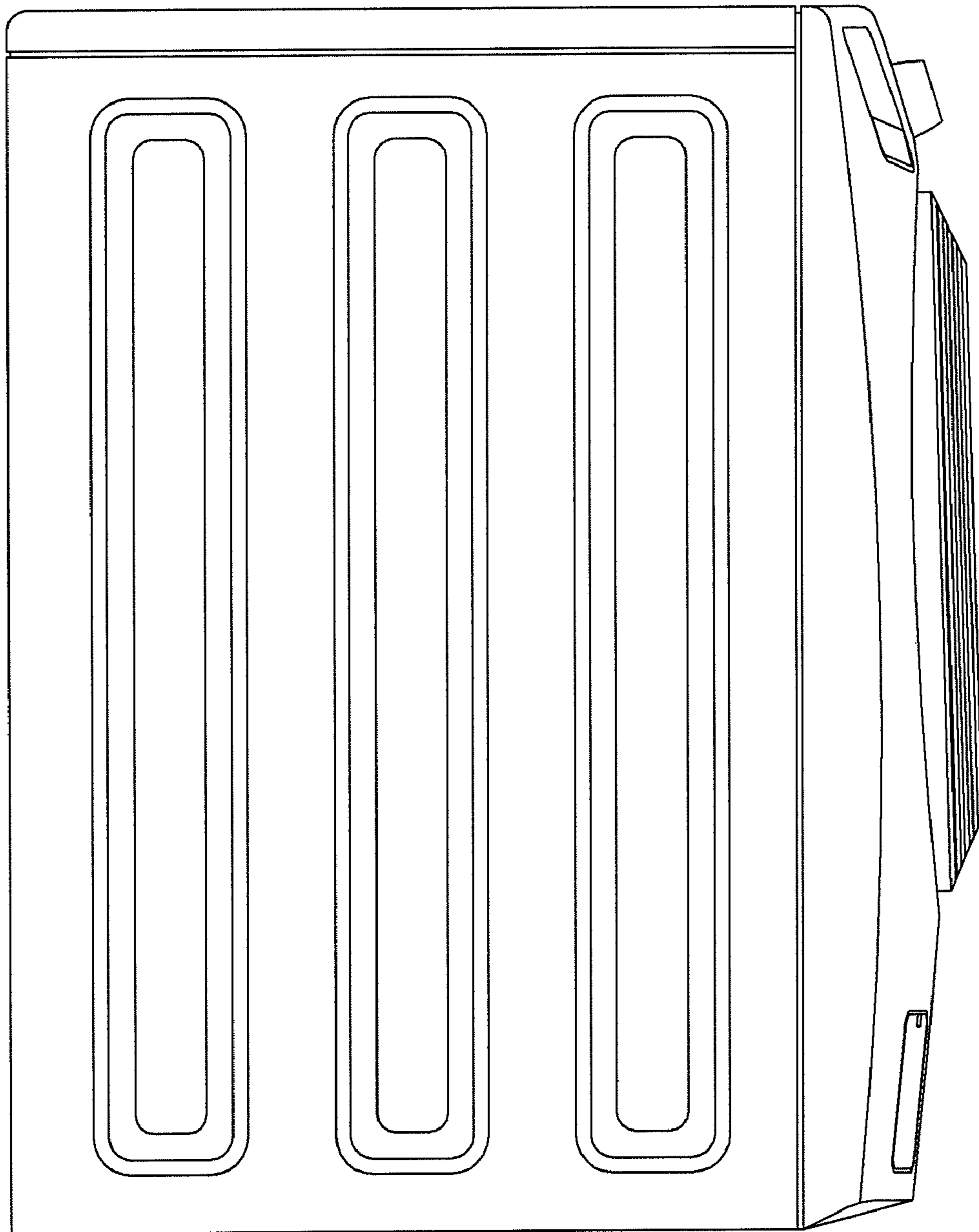

**FIG. 5**

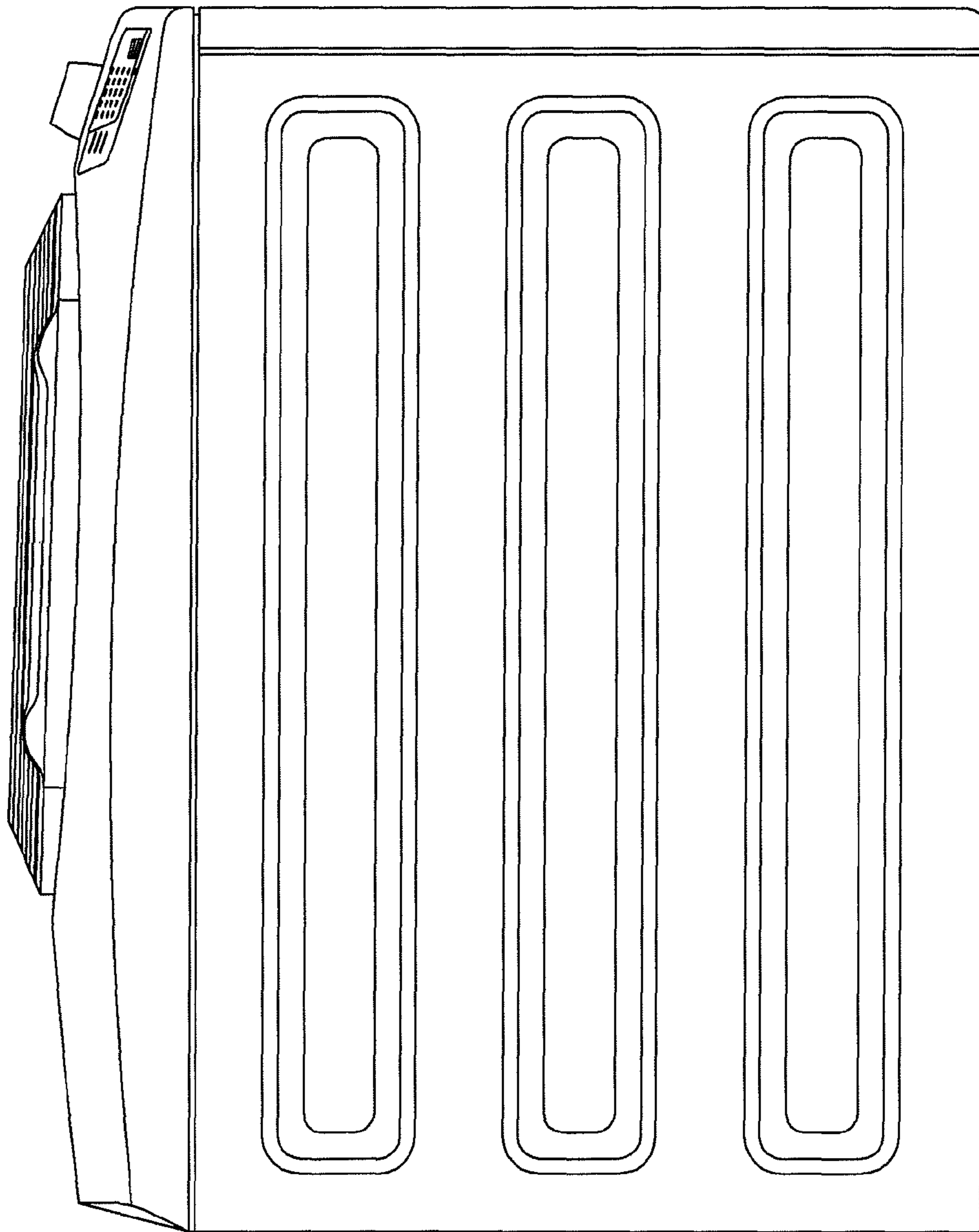

**FIG. 6**

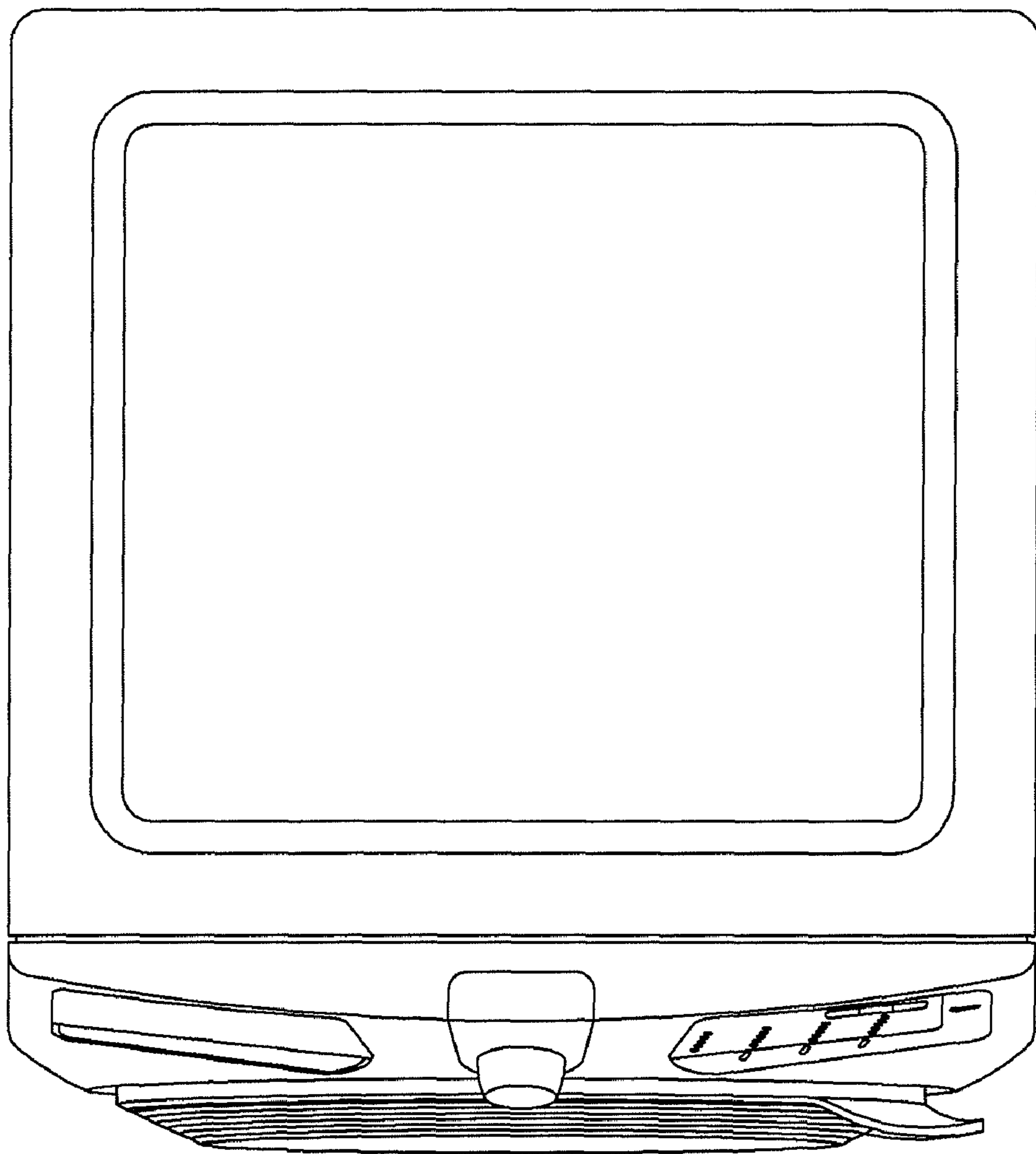

**FIG. 7**

