



US00D631437S

(12) **United States Design Patent**
Stacey

(10) **Patent No.:** **US D631,437 S**

(45) **Date of Patent:** **** Jan. 25, 2011**

(54) **BATTERY PACK KICK STAND**

(75) Inventor: **Jonathan K. Stacey**, Vancouver (CA)

(73) Assignee: **ACCO Brands USA LLC**, Lincolnshire, IL (US)

(**) Term: **14 Years**

(21) Appl. No.: **29/320,975**

(22) Filed: **Jul. 8, 2008**

(51) **LOC (9) Cl.** **13-02**

(52) **U.S. Cl.** **D13/118**

(58) **Field of Classification Search** D13/118,
D13/101, 103, 119, 184, 199; D8/349, 354,
D8/394; D14/251, 432, 434, 447; 248/447.2,
248/449, 450, 451, 454, 456

See application file for complete search history.

(56) **References Cited**

U.S. PATENT DOCUMENTS

- 5,678,793 A * 10/1997 Hill 248/206.3
- D488,128 S * 4/2004 Ho D13/118
- D543,985 S * 6/2007 Hussaini et al. D14/434

* cited by examiner

Primary Examiner—Prabhakar Deshmukh

Assistant Examiner—Derrick Holland

(74) *Attorney, Agent, or Firm*—Townsend and Townsend and Crew LLP

(57) **CLAIM**

The ornamental design for a battery pack kick stand, as shown and described.

DESCRIPTION

FIG. 1 is a front, right side, and top perspective view of a battery pack kick stand showing my new design;

FIG. 2 is a front, right side, and bottom perspective view thereof;

FIG. 3 is a rear, right side, and bottom perspective view thereof;

FIG. 4 is a front elevation view thereof;

FIG. 5 is a rear elevation view thereof;

FIG. 6 is a right side elevation view thereof;

FIG. 7 is a left side elevation view thereof;

FIG. 8 is a top plan view thereof; and,

FIG. 9 is a bottom plan view thereof.

The broken lines shown are for illustrative purposes only and form no part of the claimed design.

1 Claim, 2 Drawing Sheets

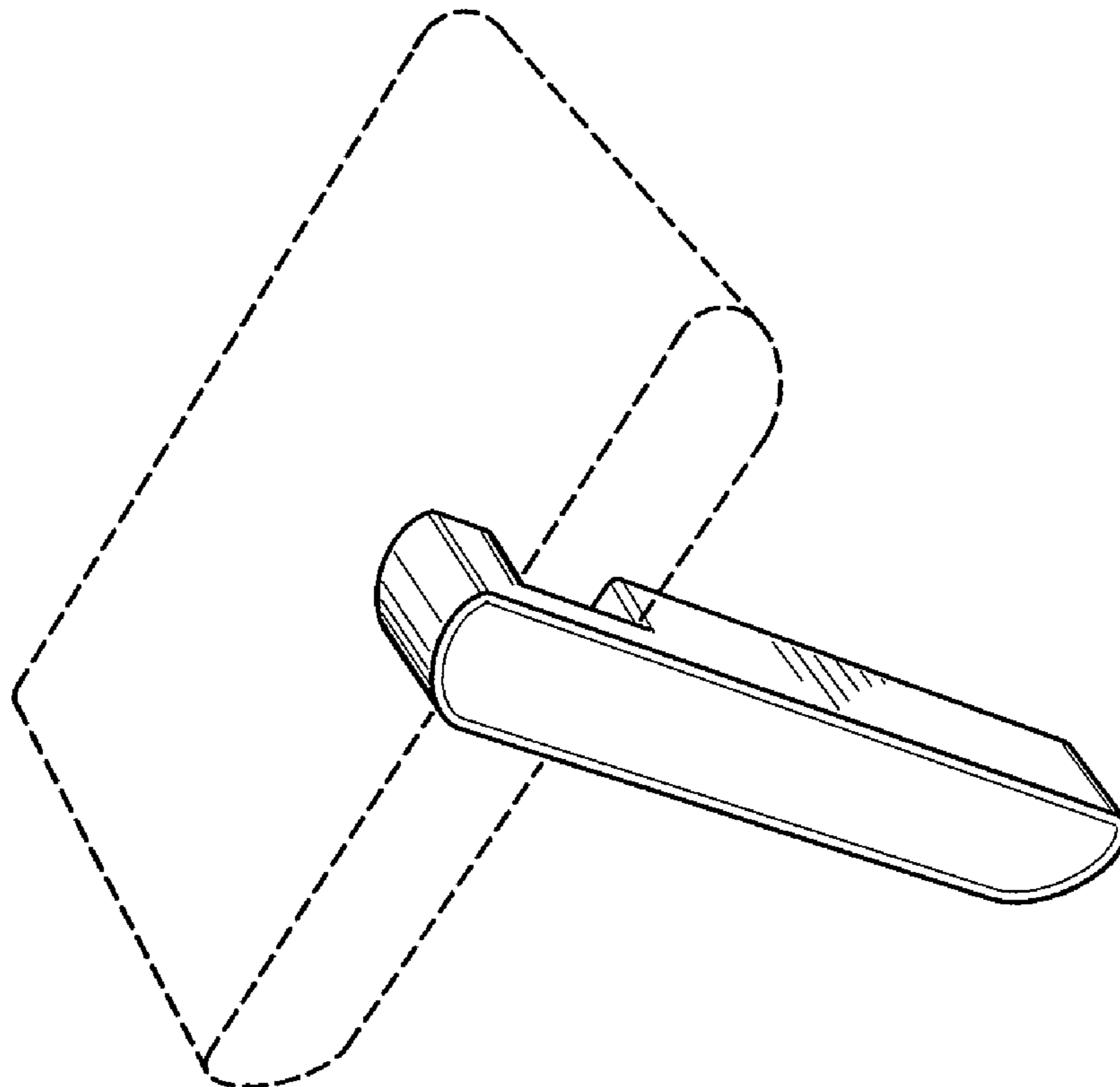

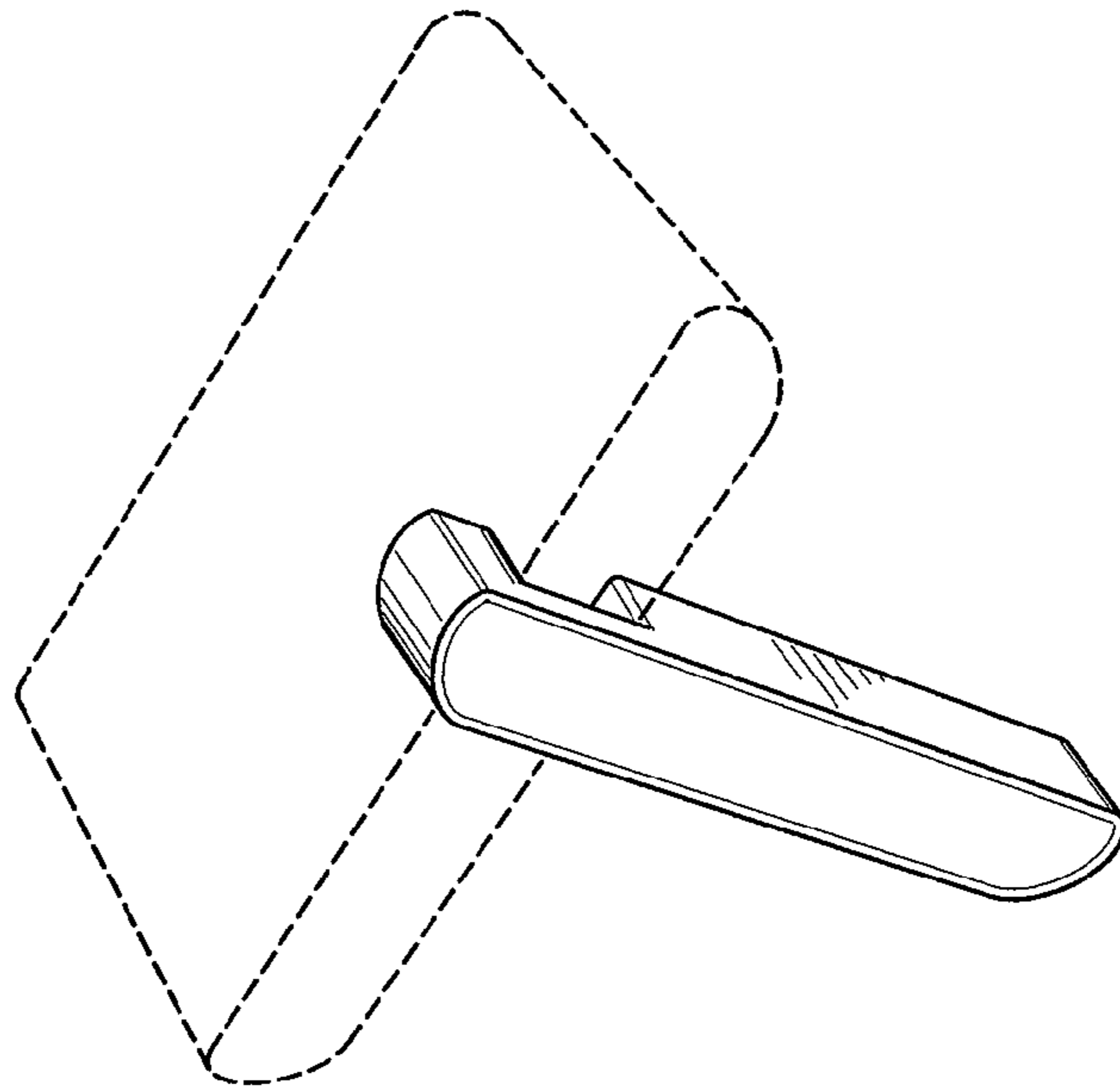

FIG. 1

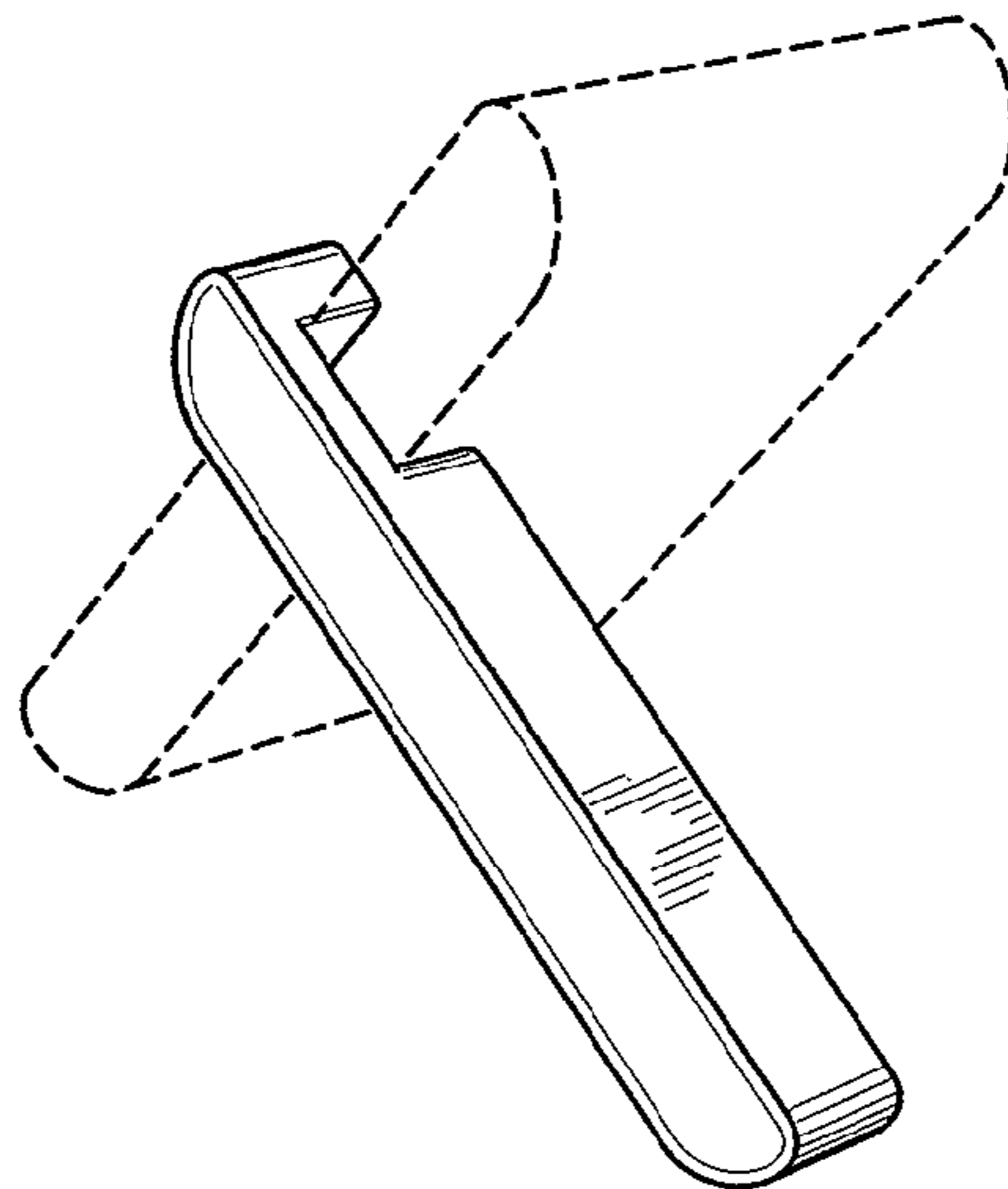

FIG. 2

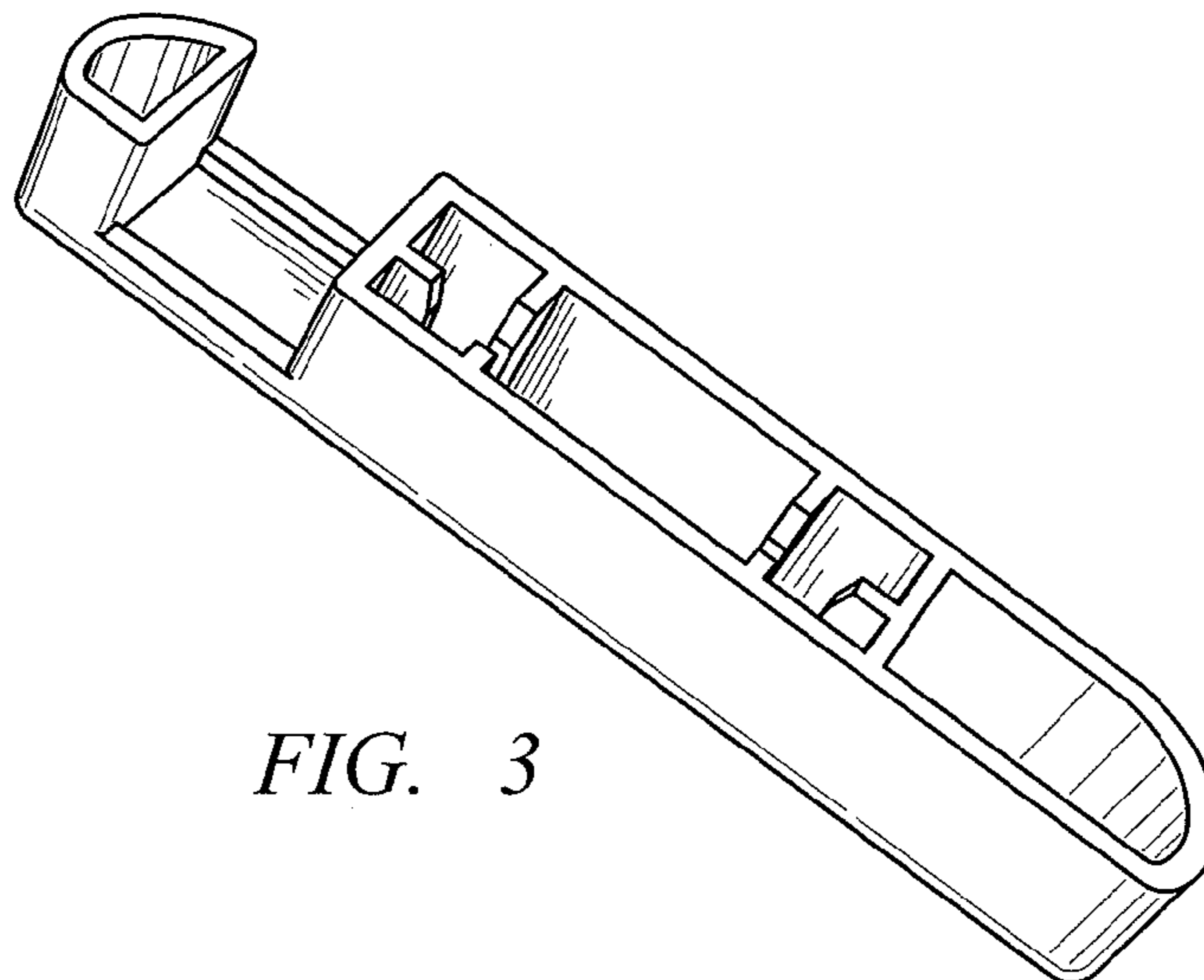

FIG. 3

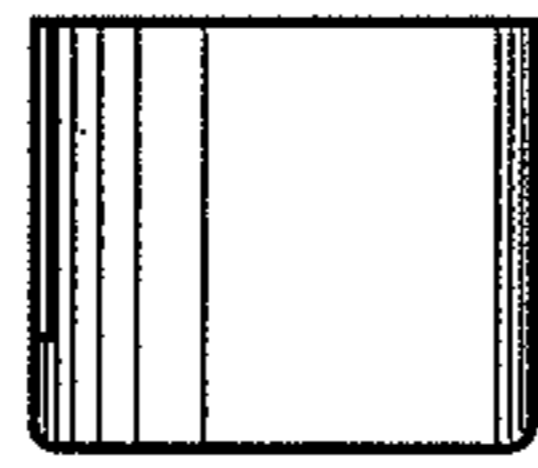

FIG. 8

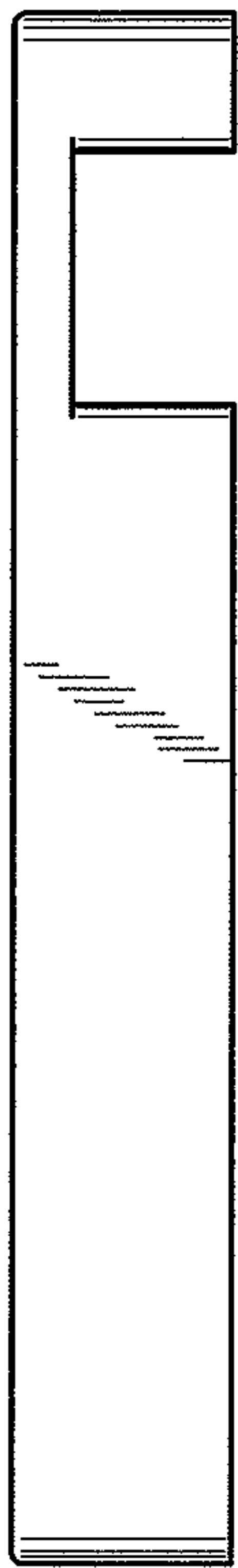

FIG. 6

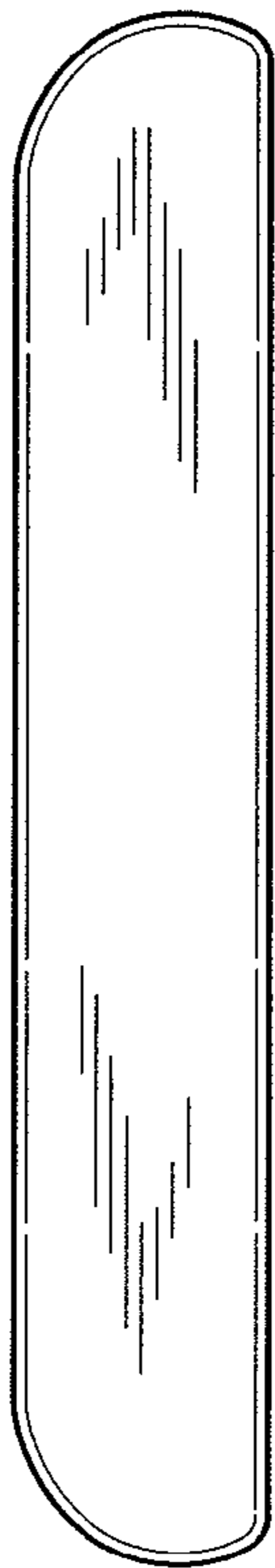

FIG. 4

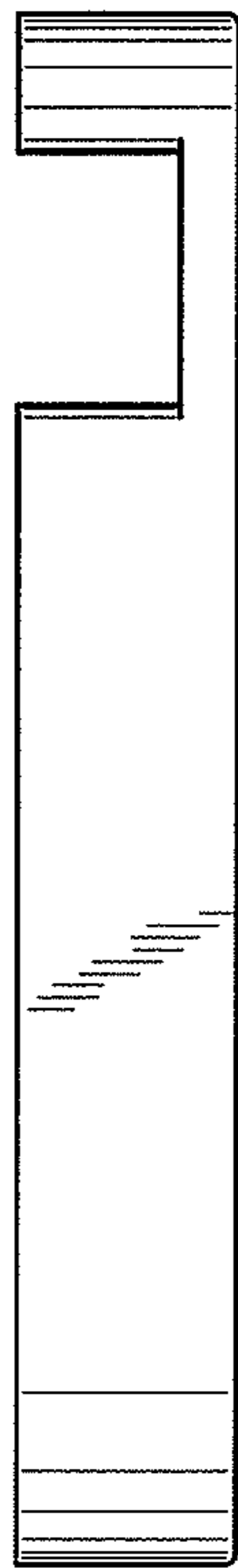

FIG. 7

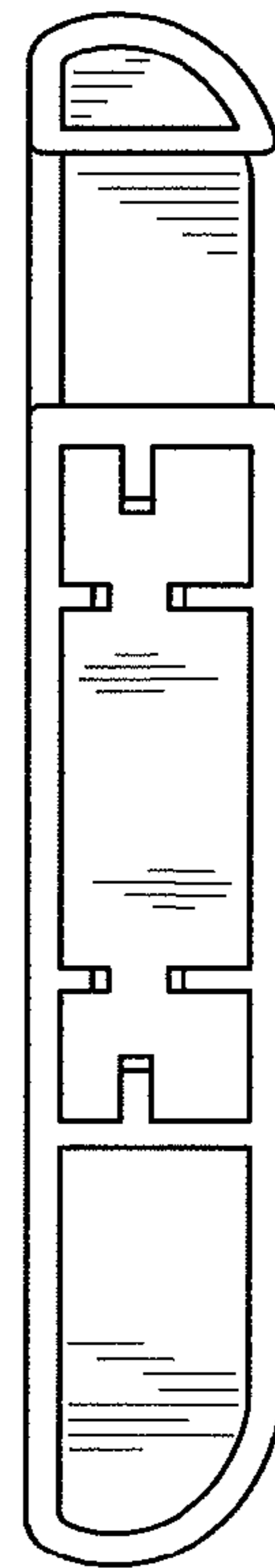

FIG. 5

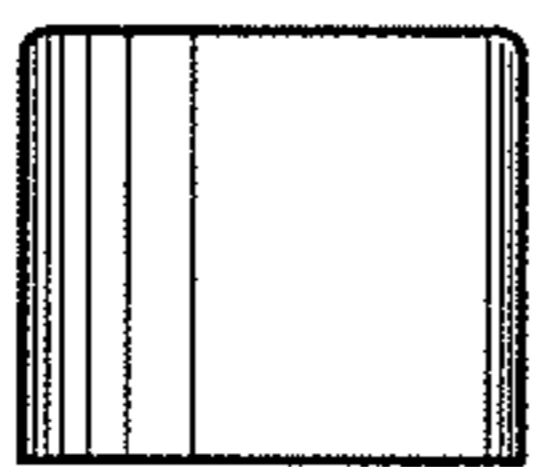

FIG. 9