

US00D631417S

(12) **United States Design Patent**
Lai

(10) **Patent No.:** **US D631,417 S**
(45) **Date of Patent:** **** Jan. 25, 2011**

(54) **EXHAUST PIPE**

6,581,376 B1 * 6/2003 Thomas 60/312

(76) Inventor: **Jhen-Yang Lai**, No. 10-25, Hen Lane,
Meigan Tsuen, Datsun, Changhua (TW)
51545

* cited by examiner

Primary Examiner—T. Chase Nelson

Assistant Examiner—Michael A Pratt

(74) *Attorney, Agent, or Firm*—Charles E. Baxley

(**) Term: **14 Years**

(21) Appl. No.: **29/348,933**

(57) **CLAIM**

(22) Filed: **Feb. 23, 2010**

The ornamental design for an exhaust pipe, as shown and described.

(51) **LOC (9) Cl.** **12-16**

(52) **U.S. Cl.** **D12/194**

(58) **Field of Classification Search** D12/194;
D15/5; 293/113; 29/890.08; 180/89.2, 296,
180/309; 181/247–249, 264, 282, 239–241,
181/227, 228; 138/44, 37–39, 103, 109;
60/303, 313, 323

See application file for complete search history.

DESCRIPTION

FIG. 1 is a perspective view of an exhaust pipe showing my new design;

FIG. 2 is a front elevational view thereof;

FIG. 3 is a rear elevational view thereof;

FIG. 4 is a top plan view thereof, the inner structure at the ends of the pipes depicted by means of broken lines forming no part of the claimed design;

FIG. 5 is a bottom plan view thereof, the inner structure at the ends of the pipes depicted by means of broken lines forming no part of the claimed design;

FIG. 6 is a left side elevational view thereof; and,

FIG. 7 is a right side elevational view thereof.

(56) **References Cited**

U.S. PATENT DOCUMENTS

- 2,940,249 A * 6/1960 Gospodar 60/313
- 3,043,098 A * 7/1962 Hannon 165/52
- D214,037 S * 5/1969 Flugger D12/194
- 3,516,247 A * 6/1970 Knox, Jr. 60/324
- 3,545,414 A * 12/1970 Thompson 60/323

1 Claim, 4 Drawing Sheets

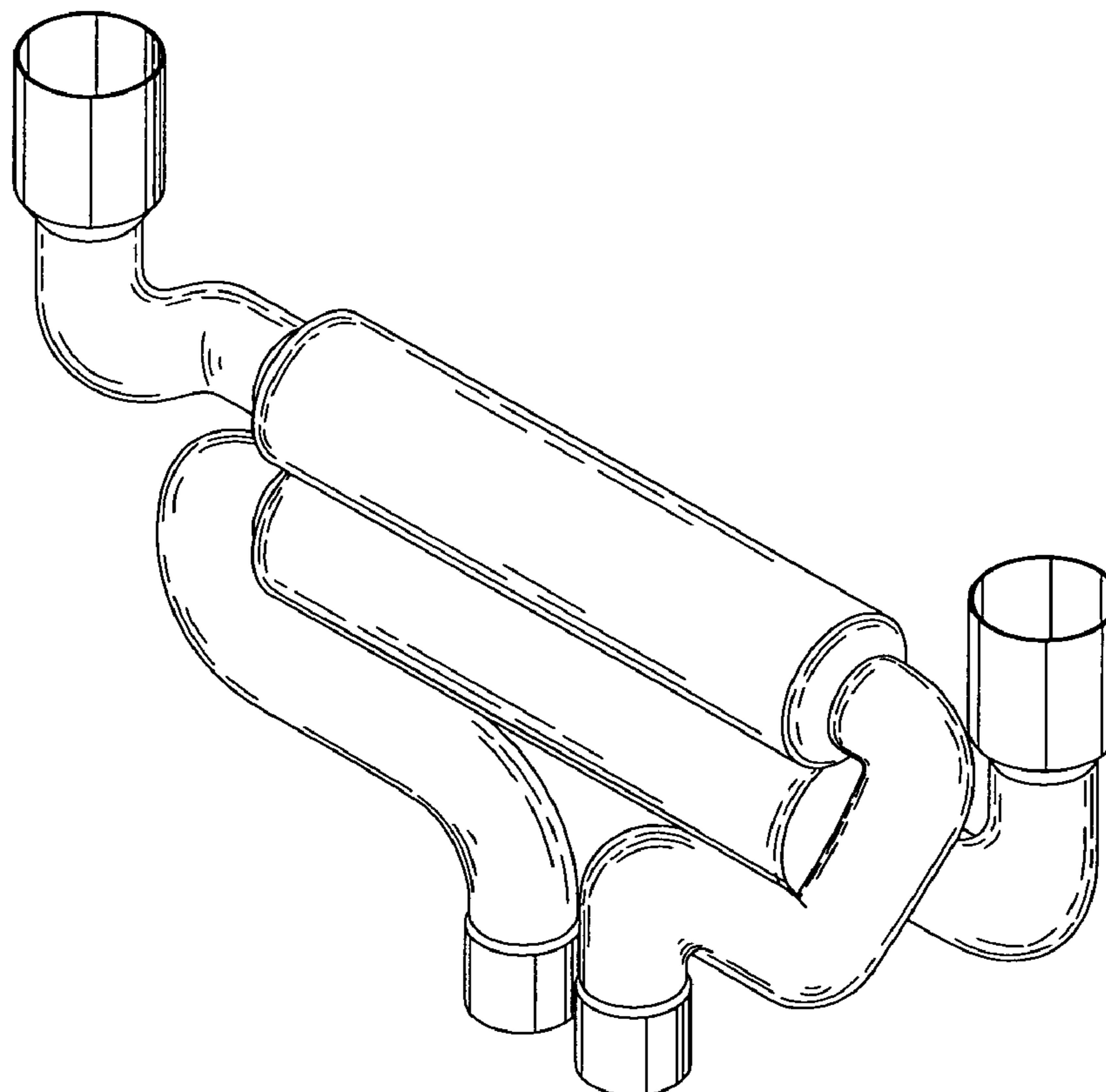

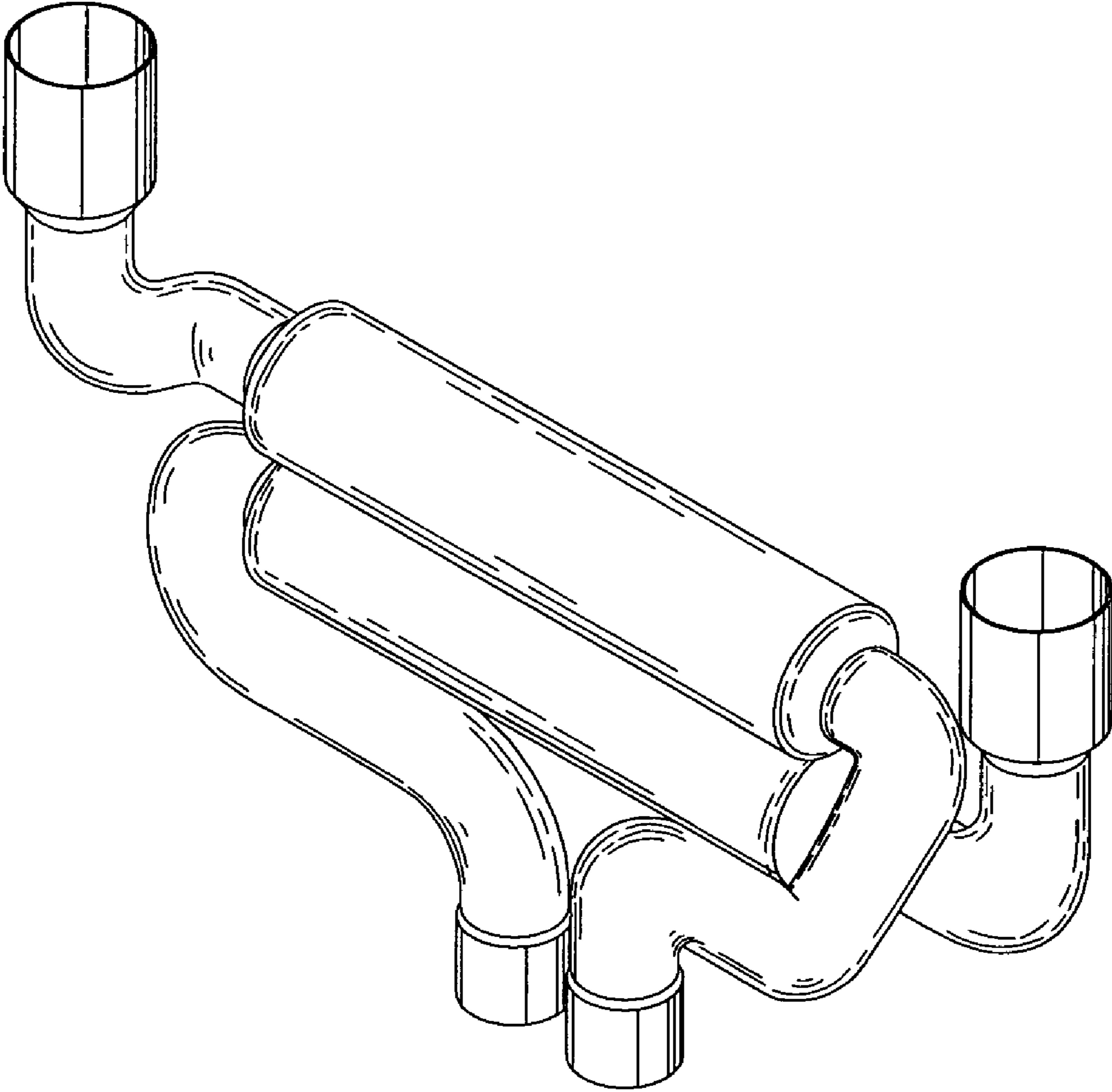

FIG. 1

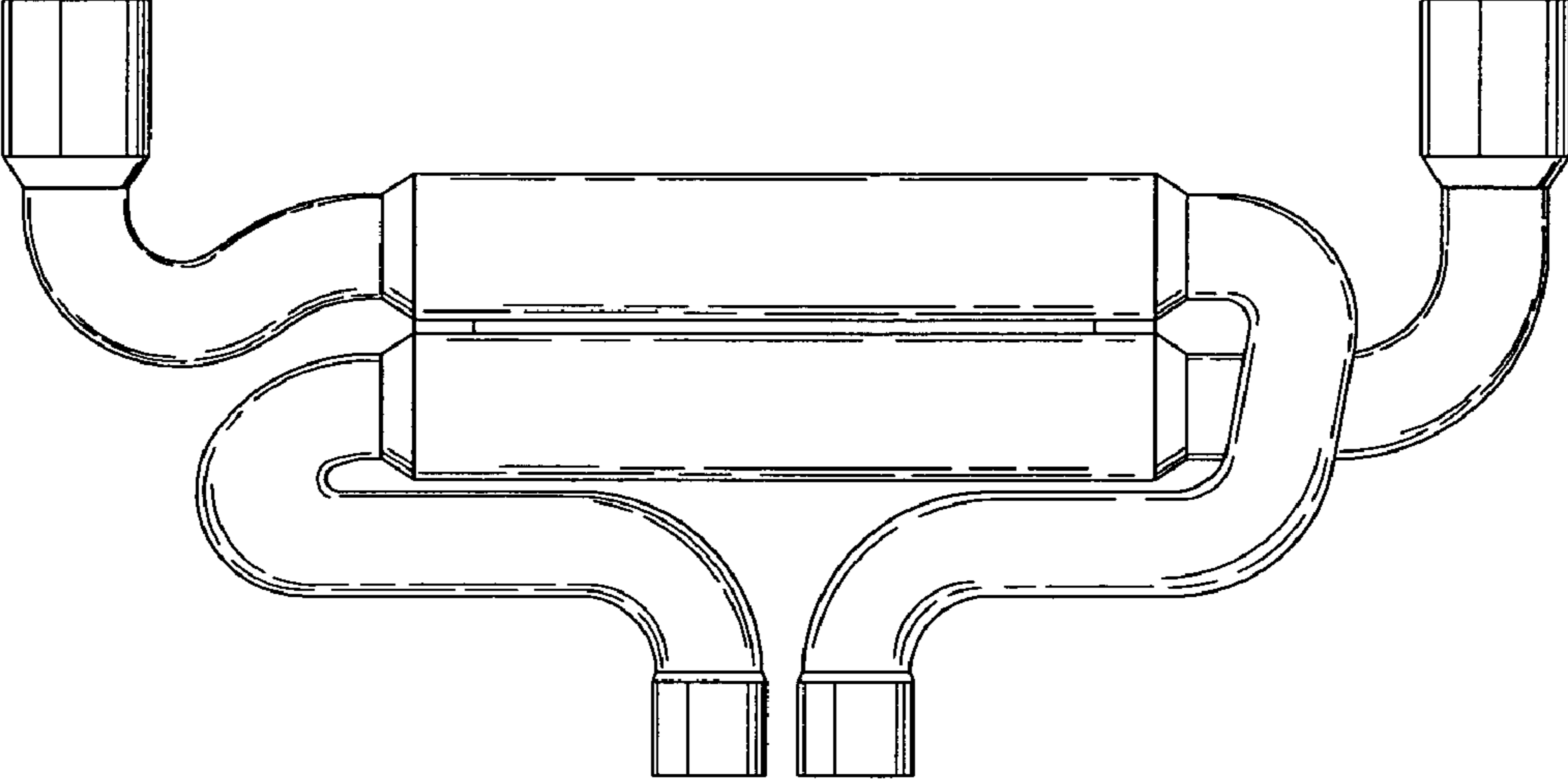

FIG. 2

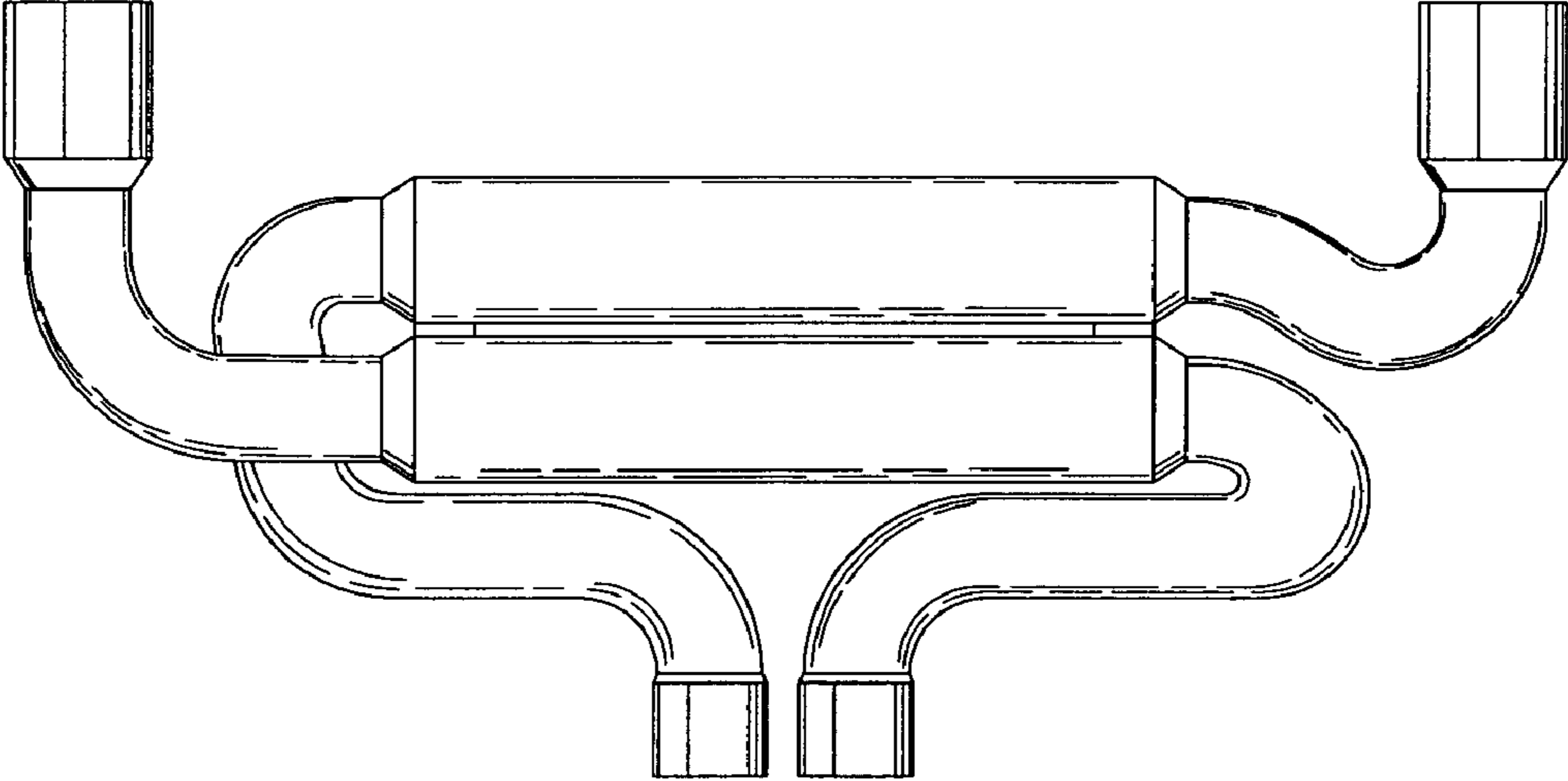

FIG. 3

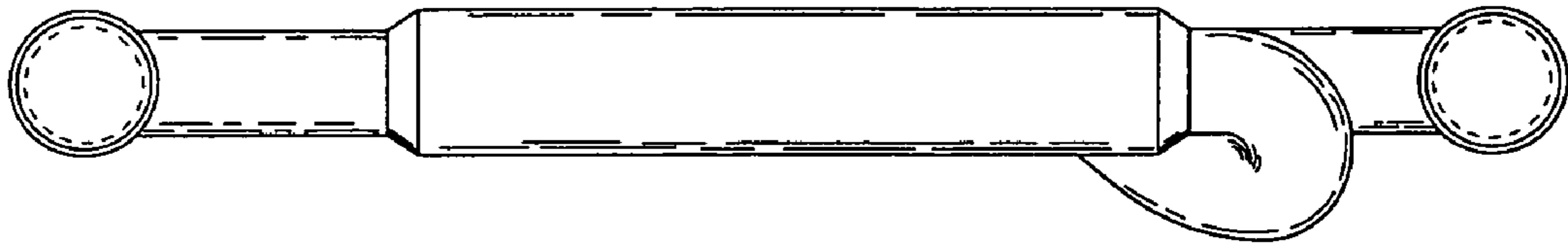

FIG. 4

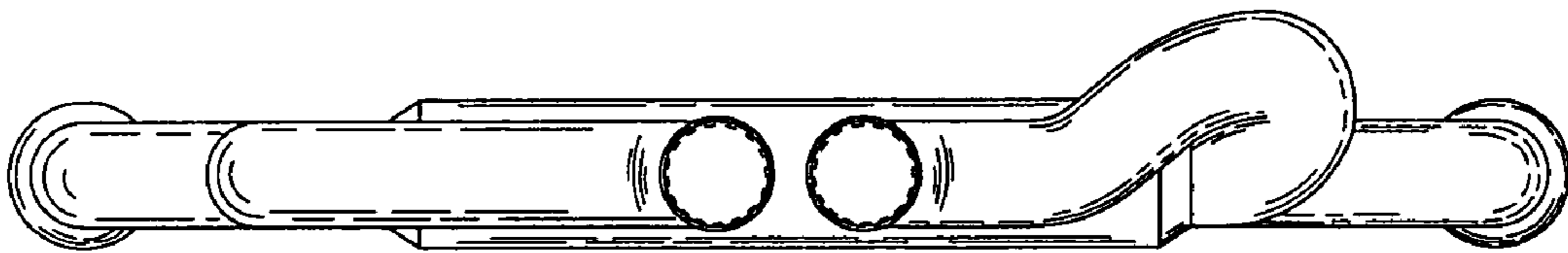

FIG. 5

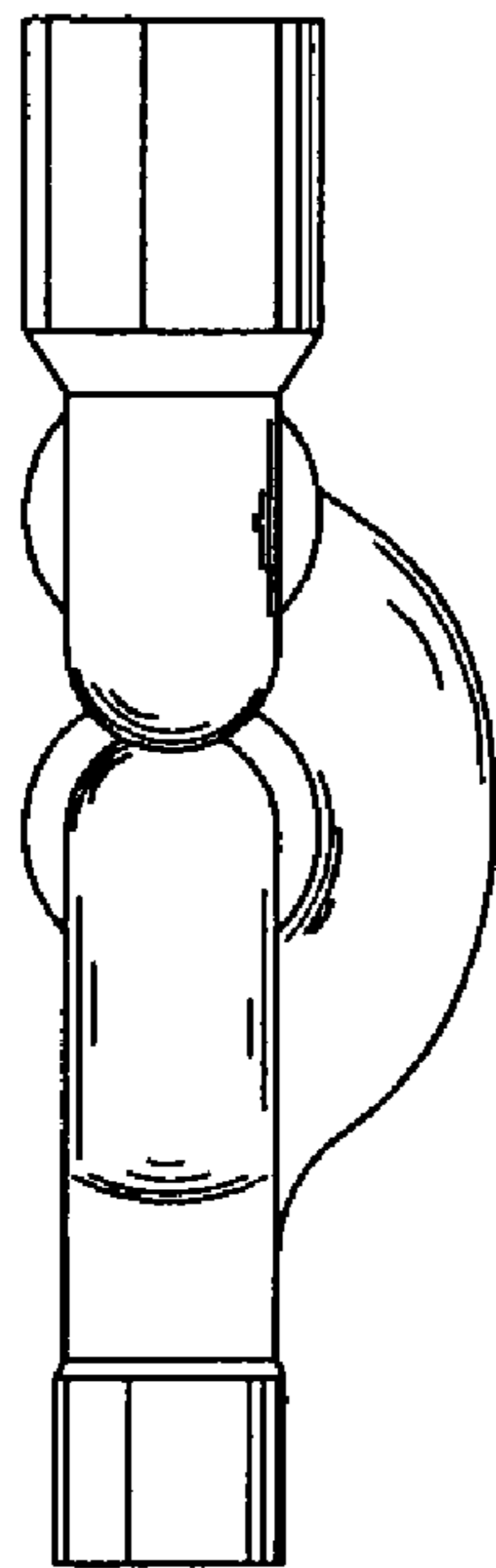

FIG. 6

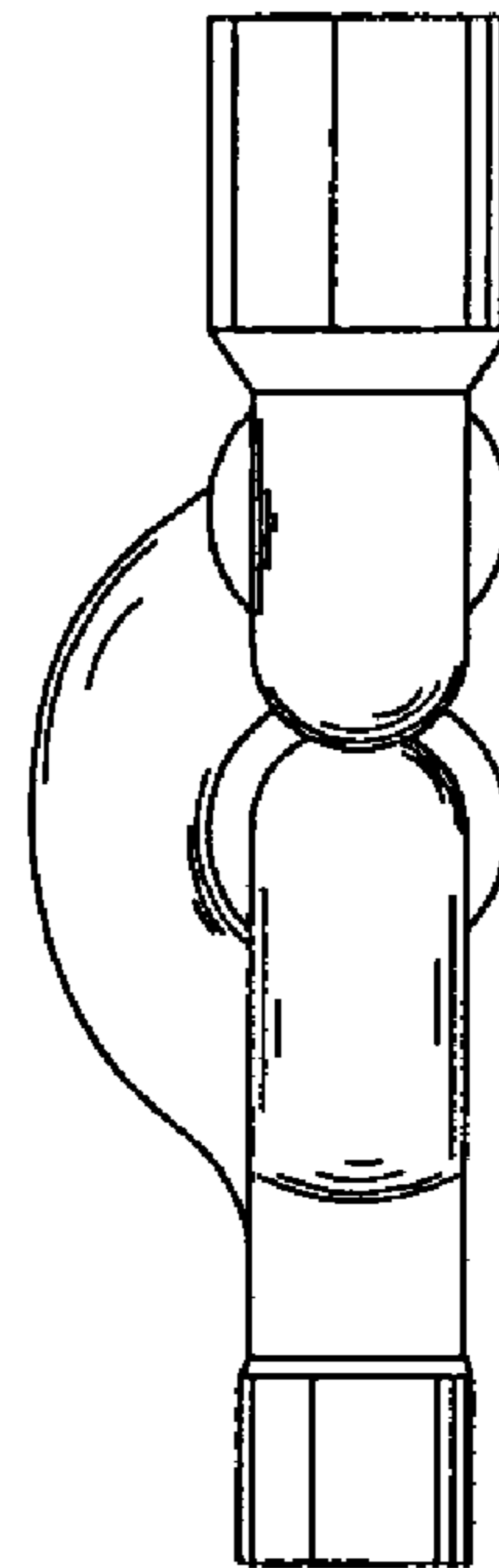

FIG. 7