



US00D631405S

(12) **United States Design Patent**  
**Kuze**

(10) **Patent No.:** **US D631,405 S**  
(45) **Date of Patent:** **\*\* Jan. 25, 2011**

(54) **RADIATOR GRILL FOR AUTOMOBILE**

FOREIGN PATENT DOCUMENTS

(75) Inventor: **Takahiro Kuze**, Kamakura (JP)

JP 1337296 S 8/2008

\* cited by examiner

(73) Assignee: **Nissan Motor Co., Ltd.**, Yokohama (JP)

*Primary Examiner*—Melody N Brown

(\*\*) Term: **14 Years**

(74) *Attorney, Agent, or Firm*—Global IP Counselors, LLP

(21) Appl. No.: **29/368,226**

(57) **CLAIM**

(22) Filed: **Aug. 20, 2010**

The ornamental design for a radiator grill for an automobile, as shown and described.

(30) **Foreign Application Priority Data**

**DESCRIPTION**

Feb. 26, 2010 (JP) ..... 2010-004535

(51) **LOC (9) Cl.** ..... **12-16**

(52) **U.S. Cl.** ..... **D12/163**

(58) **Field of Classification Search** ..... D12/163,  
D12/196, 171, 169, 216, 90-92, 86; 180/68.1,  
180/68.6; 296/193.11

See application file for complete search history.

FIG. 1 is a front elevational view of a radiator grill for an automobile in accordance with my new design;

FIG. 2 is a rear elevational view of the radiator grill for an automobile in accordance with my new design;

FIG. 3 is a top plan view of the radiator grill for an automobile in accordance with my new design;

FIG. 4 is a bottom plan view of the radiator grill for an automobile in accordance with my new design;

FIG. 5 is a right side elevational view of the radiator grill for an automobile in accordance with my new design;

FIG. 6 is a left side elevational view of the radiator grill for an automobile in accordance with my new design; and,

FIG. 7 is a front and side perspective view of the radiator grill for an automobile in accordance with my new design.

The broken line showing of the radiator grill for an automobile is for purpose of illustrating environmental structure and forms no part of the claimed design.

(56) **References Cited**

U.S. PATENT DOCUMENTS

D531,938 S *	11/2006	Okamura	.....	D12/163
D571,692 S *	6/2008	Hayashi	.....	D12/163
D575,204 S *	8/2008	Nakajima	.....	D12/163
D579,829 S *	11/2008	Hokao et al.	.....	D12/163
D592,563 S *	5/2009	Asakura et al.	.....	D12/163
D614,542 S *	4/2010	Kasai et al.	.....	D12/163
D616,341 S *	5/2010	Fukui et al.	.....	D12/163
D616,342 S *	5/2010	Kim	.....	D12/163
D620,849 S *	8/2010	Kaoud et al.	.....	D12/163

**1 Claim, 5 Drawing Sheets**

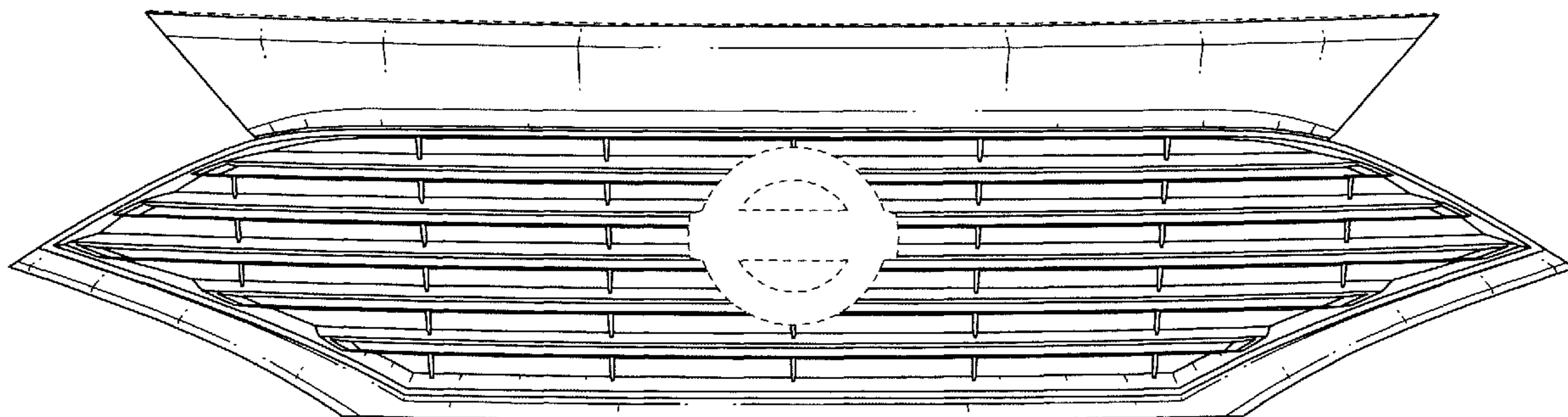

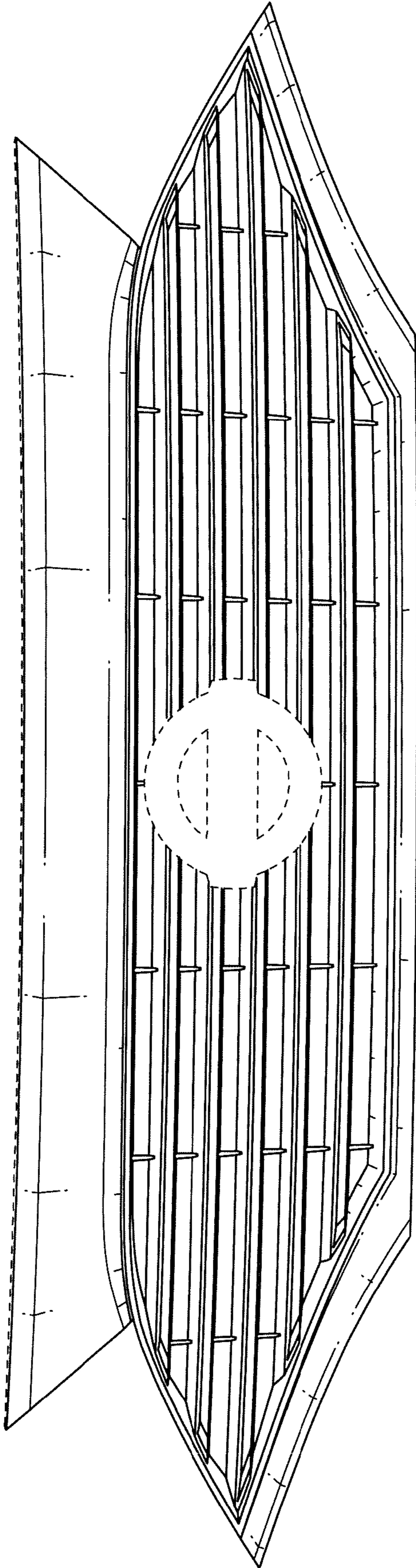

FIG. 1

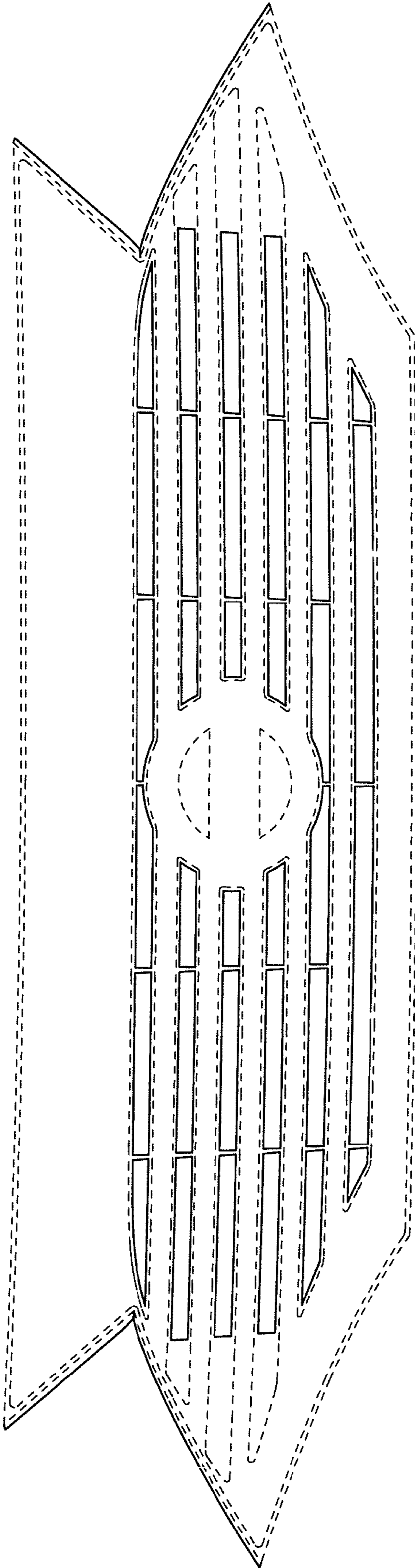

FIG. 2



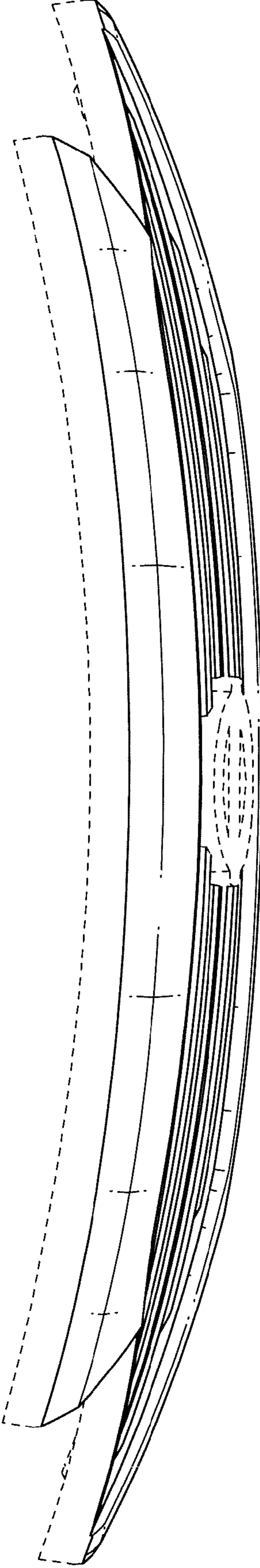

FIG. 3

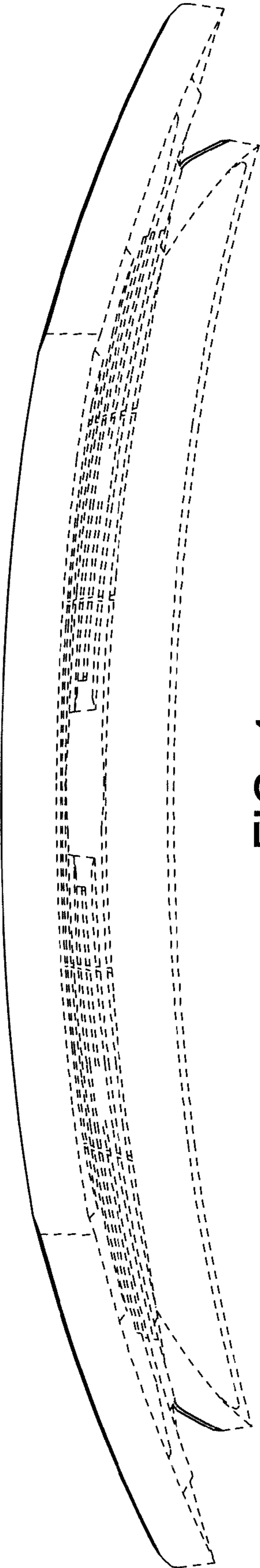

FIG. 4

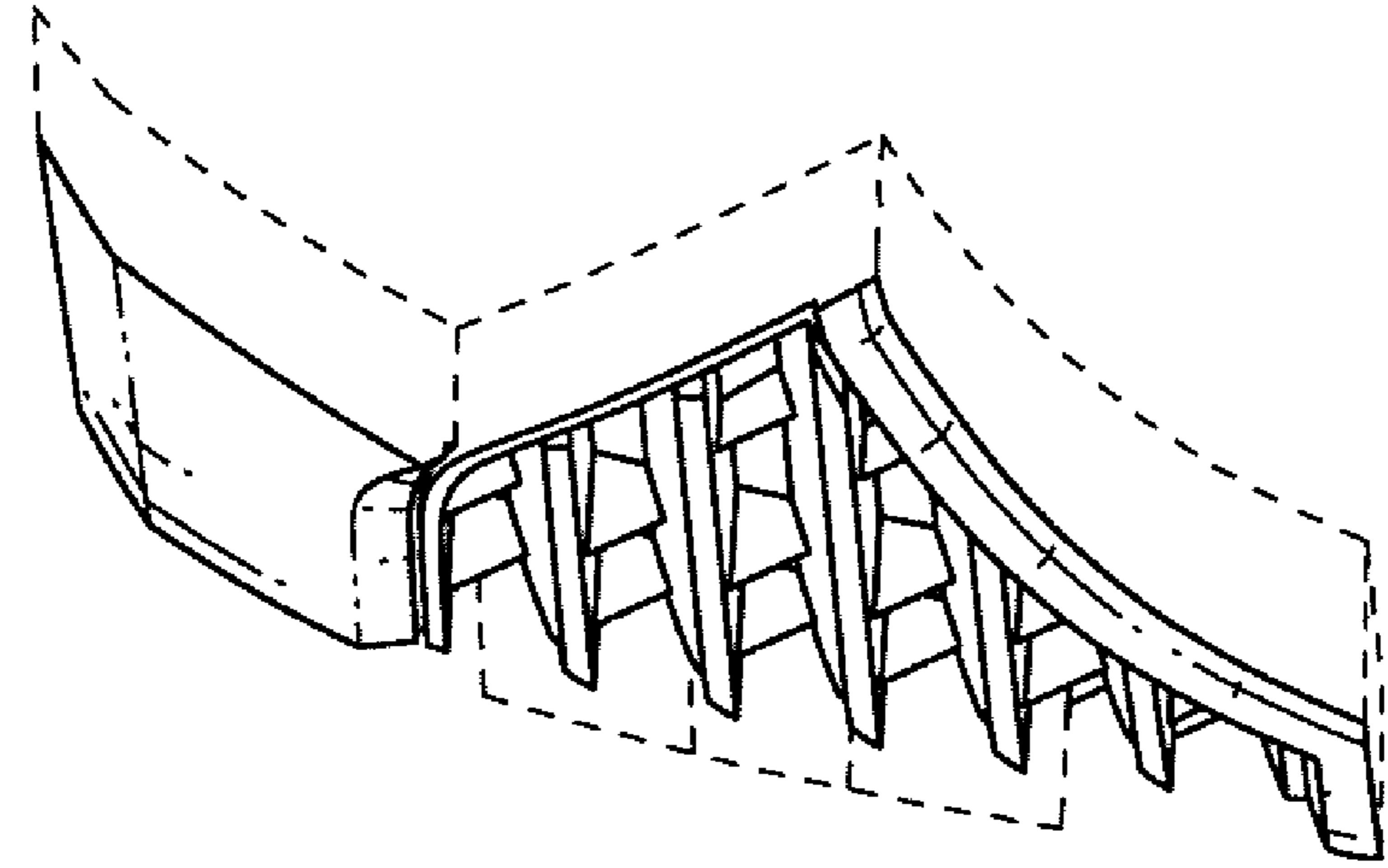

FIG. 6

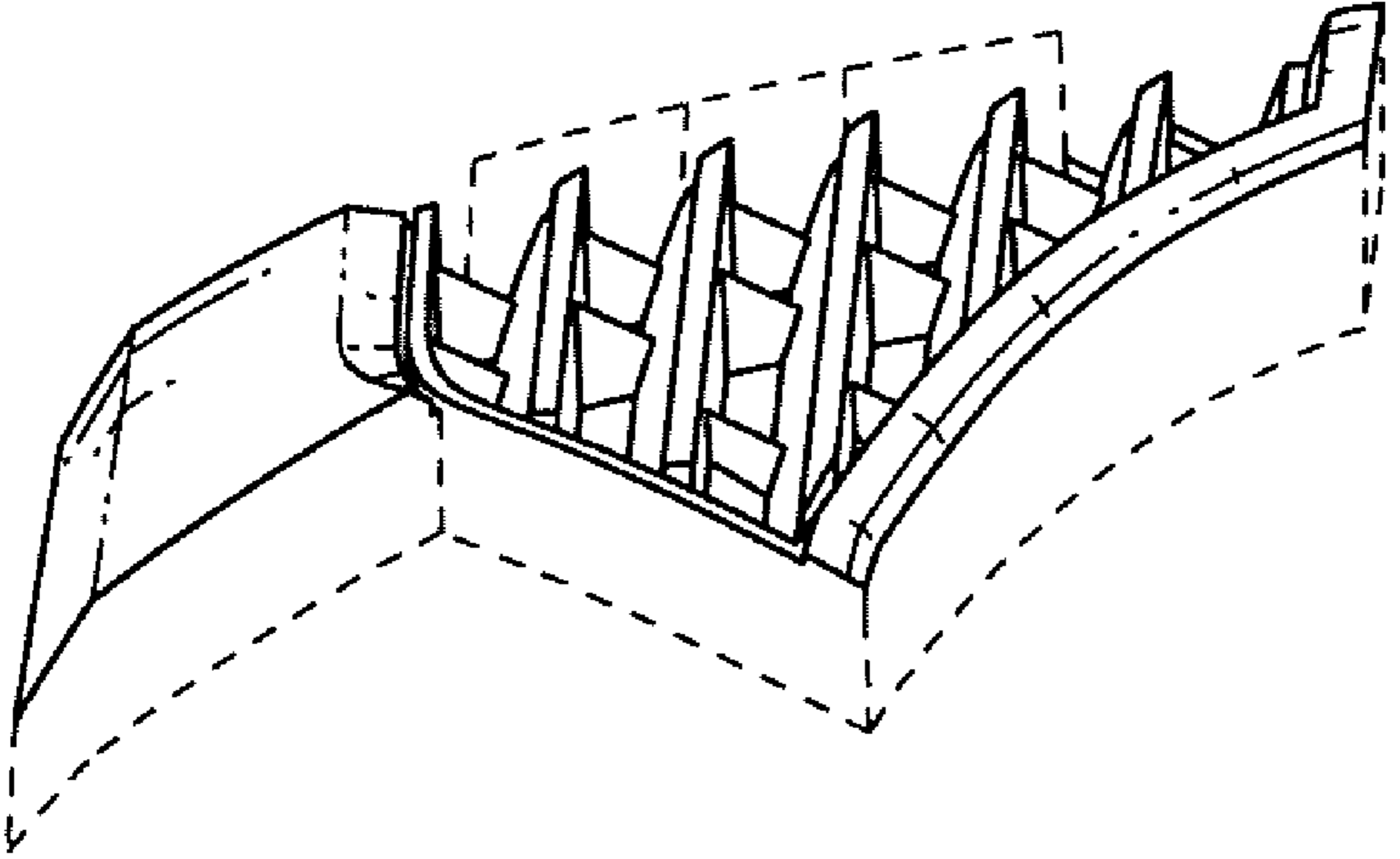

FIG. 5

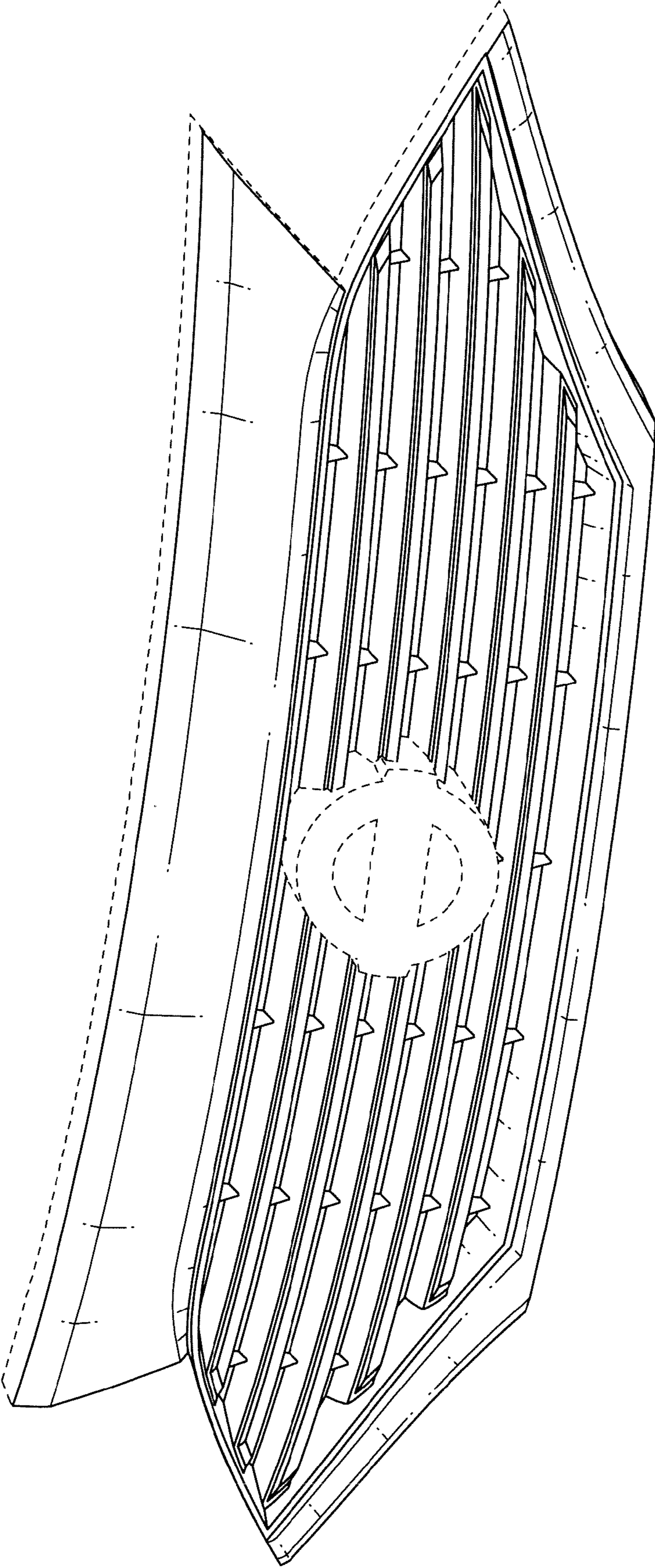

FIG. 7