



US00D631398S

(12) **United States Design Patent**
Oda et al.

(10) **Patent No.:** **US D631,398 S**
(45) **Date of Patent:** **** Jan. 25, 2011**

(54) **VEHICLE AND/OR REPLICA THEREOF**
(75) Inventors: **Hiroshi Oda**, Kanagawa (JP); **Takahiro Kuze**, Kamakura (JP)
(73) Assignee: **Nissan Motor Co., Ltd.**, Yokohama (JP)
(**) Term: **14 Years**

(21) Appl. No.: **29/368,222**

(22) Filed: **Aug. 20, 2010**

(30) **Foreign Application Priority Data**

Feb. 26, 2010 (JP) 2010-004547

(51) **LOC (9) Cl.** **12-08**

(52) **U.S. Cl.** **D12/91**

(58) **Field of Classification Search** D12/86,
D12/90-92; D21/424, 433, 434; 296/181.1,
296/181.5

See application file for complete search history.

(56) **References Cited**

U.S. PATENT DOCUMENTS

D578,437 S * 10/2008 Nishihata et al. D12/91
D586,262 S * 2/2009 Wang et al. D12/91
D591,202 S * 4/2009 Ohhashi et al. D12/91
D622,633 S * 8/2010 Nakamura et al. D12/91
D622,634 S * 8/2010 Yamamoto et al. D12/91
D623,988 S * 9/2010 Liu et al. D12/91

FOREIGN PATENT DOCUMENTS

JP 1337296 S 8/2008

* cited by examiner

Primary Examiner—Melody N Brown
(74) *Attorney, Agent, or Firm*—Global IP Counselors, LLP

(57) **CLAIM**

The ornamental design for a vehicle and/or replica thereof, as shown and described.

DESCRIPTION

FIG. 1 is a right side elevational view of a vehicle and/or a replica thereof in accordance with our new design;

FIG. 2 is a left side elevational view of the vehicle and/or replica thereof in accordance with our new design;

FIG. 3 is a top plan view of the vehicle and/or replica thereof in accordance with our new design;

FIG. 4 is a bottom plan view of the vehicle and/or replica thereof in accordance with our new design;

FIG. 5 is a front elevational view of the vehicle and/or replica thereof in accordance with our new design;

FIG. 6 is a rear elevational view of the vehicle and/or replica thereof in accordance with our new design;

FIG. 7 is a front and side perspective view of the vehicle and/or replica thereof in accordance with our new design; and,

FIG. 8 is a rear and side perspective view of the vehicle and/or replica thereof in accordance with our new design.

The broken line showing of the vehicle and/or replica thereof is for purpose of illustrating environmental structure and forms no part of the claimed design.

1 Claim, 7 Drawing Sheets

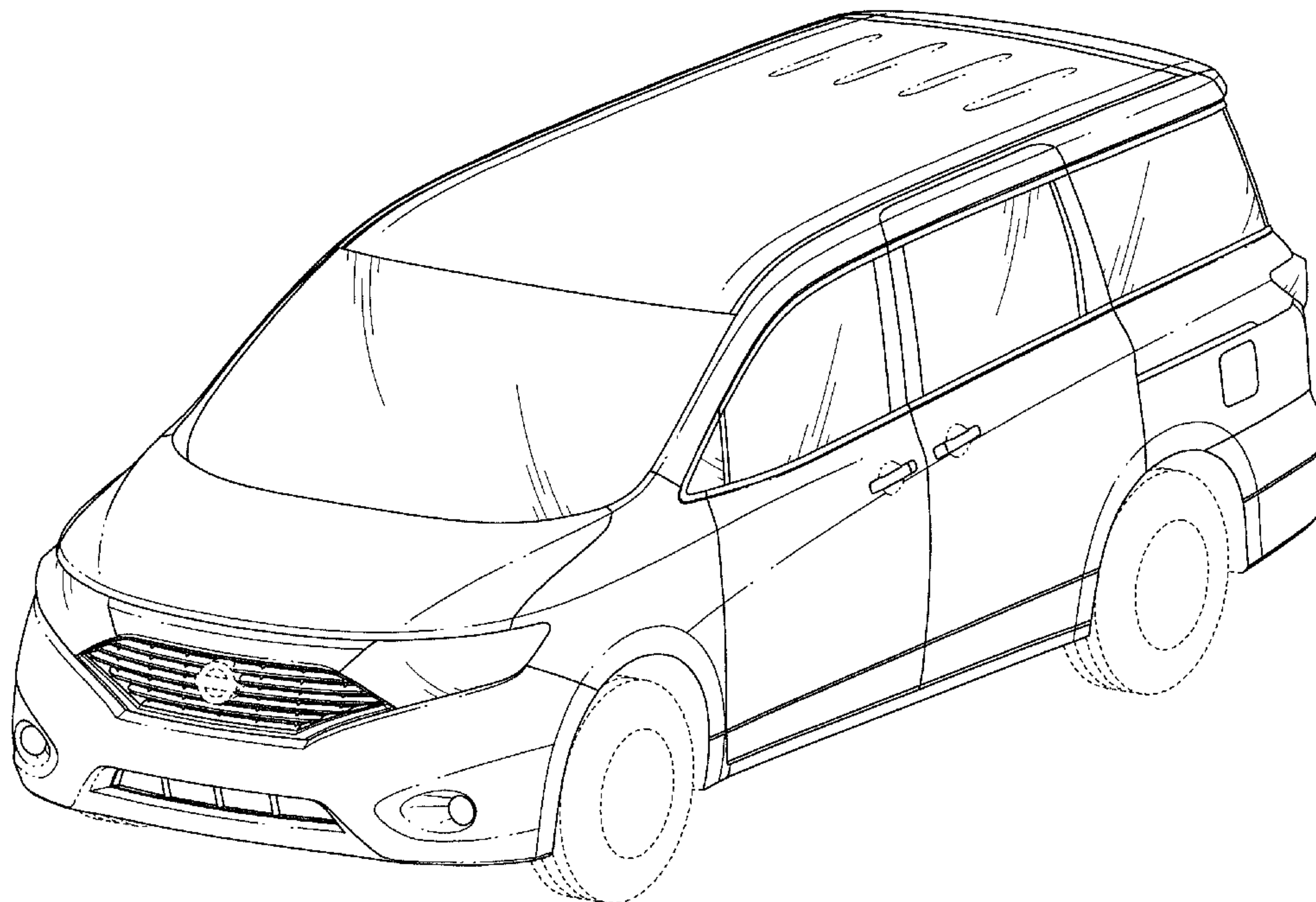

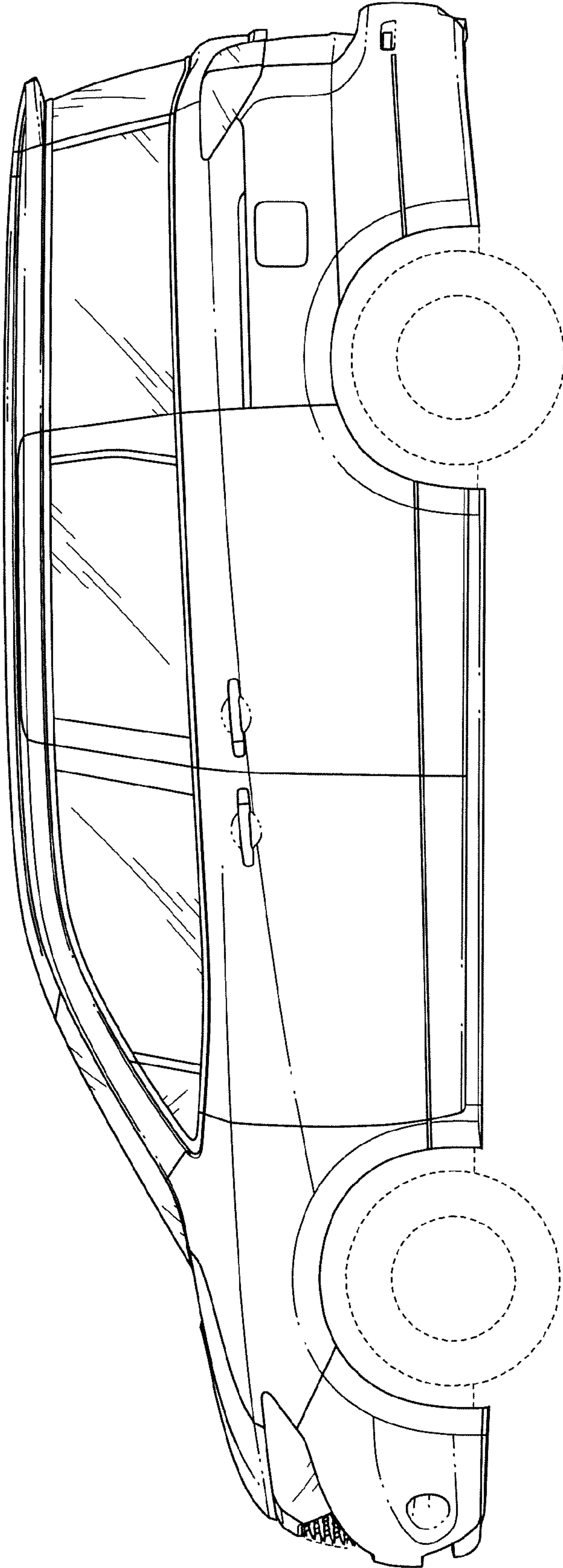

FIG. 1

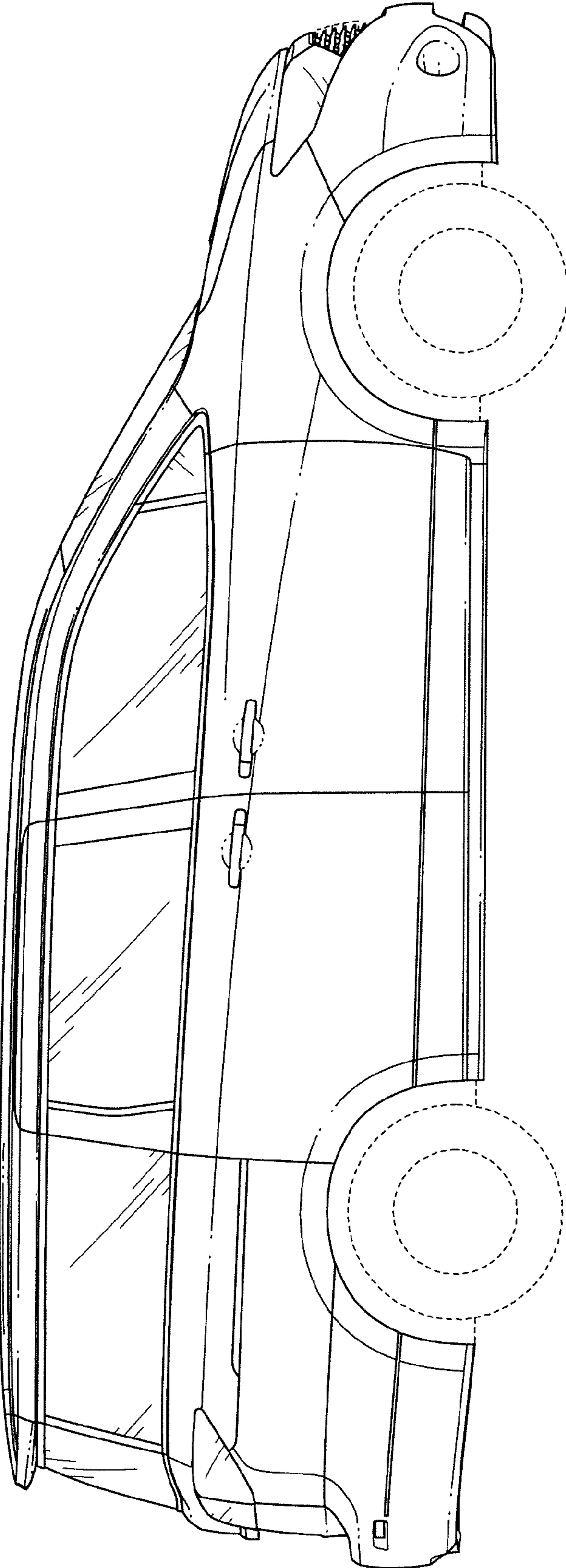

FIG. 2

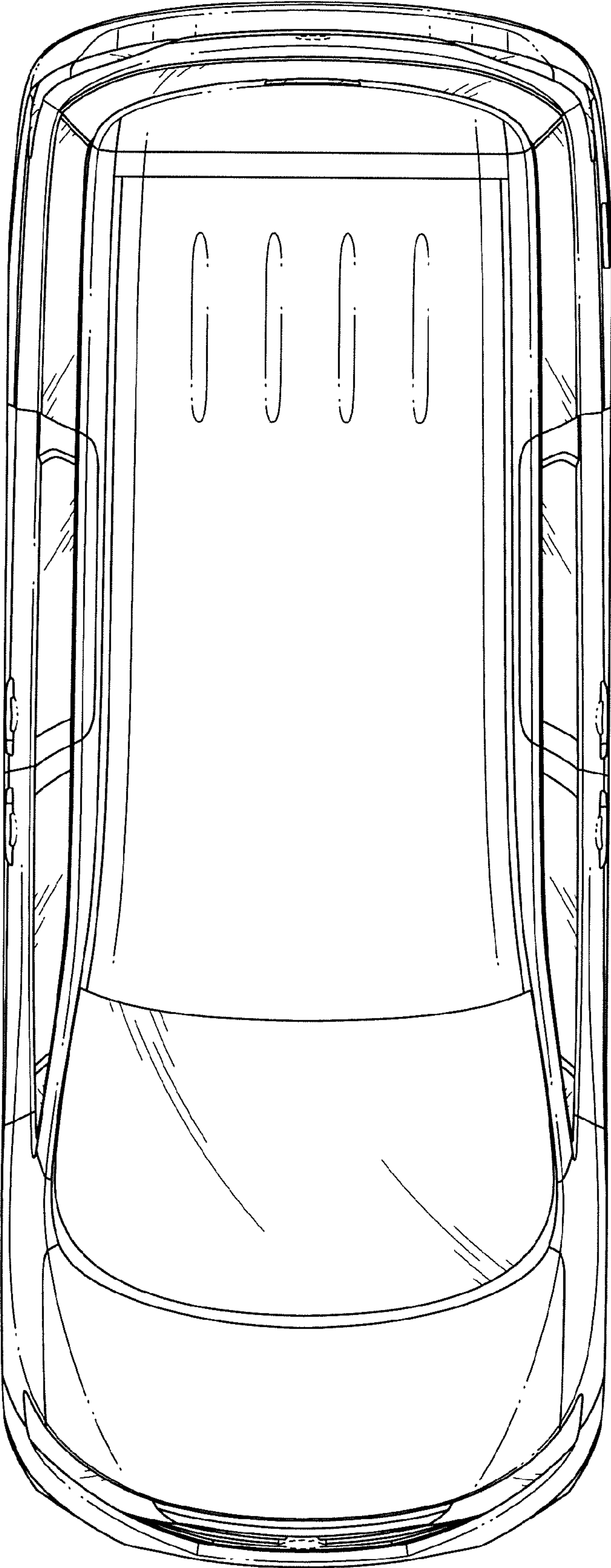

FIG. 3

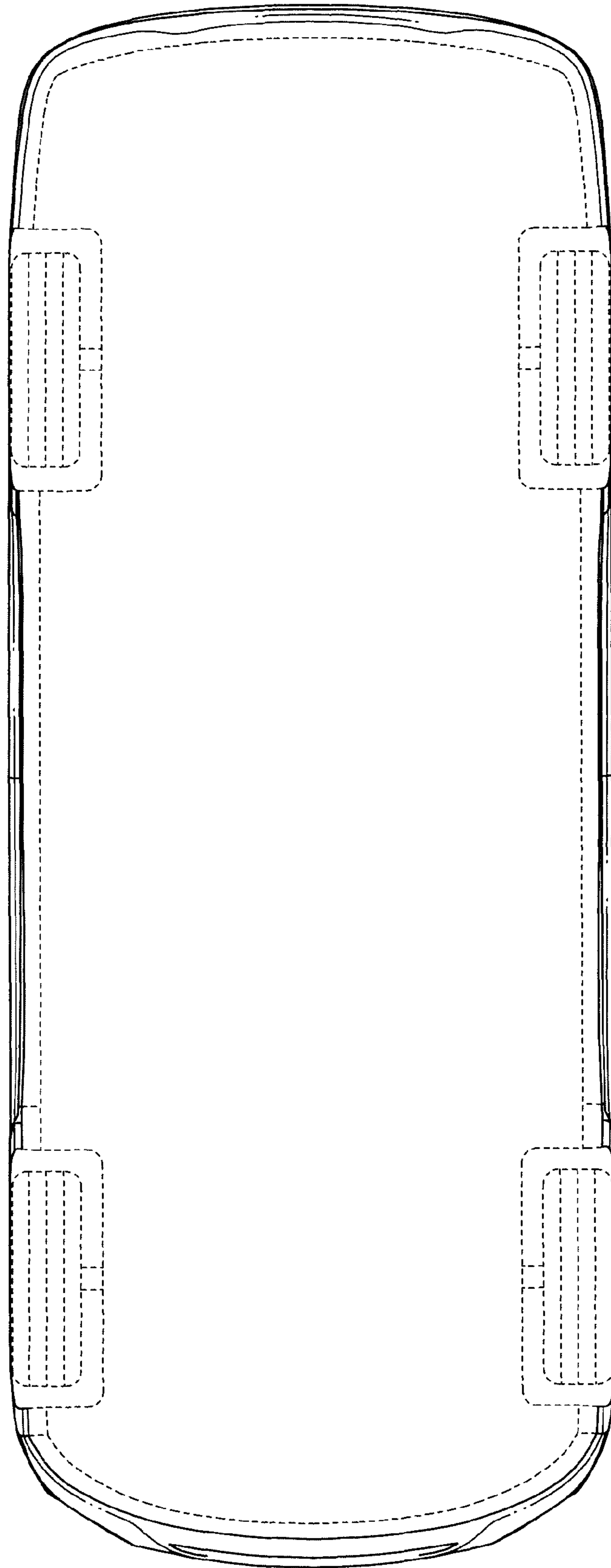

FIG. 4

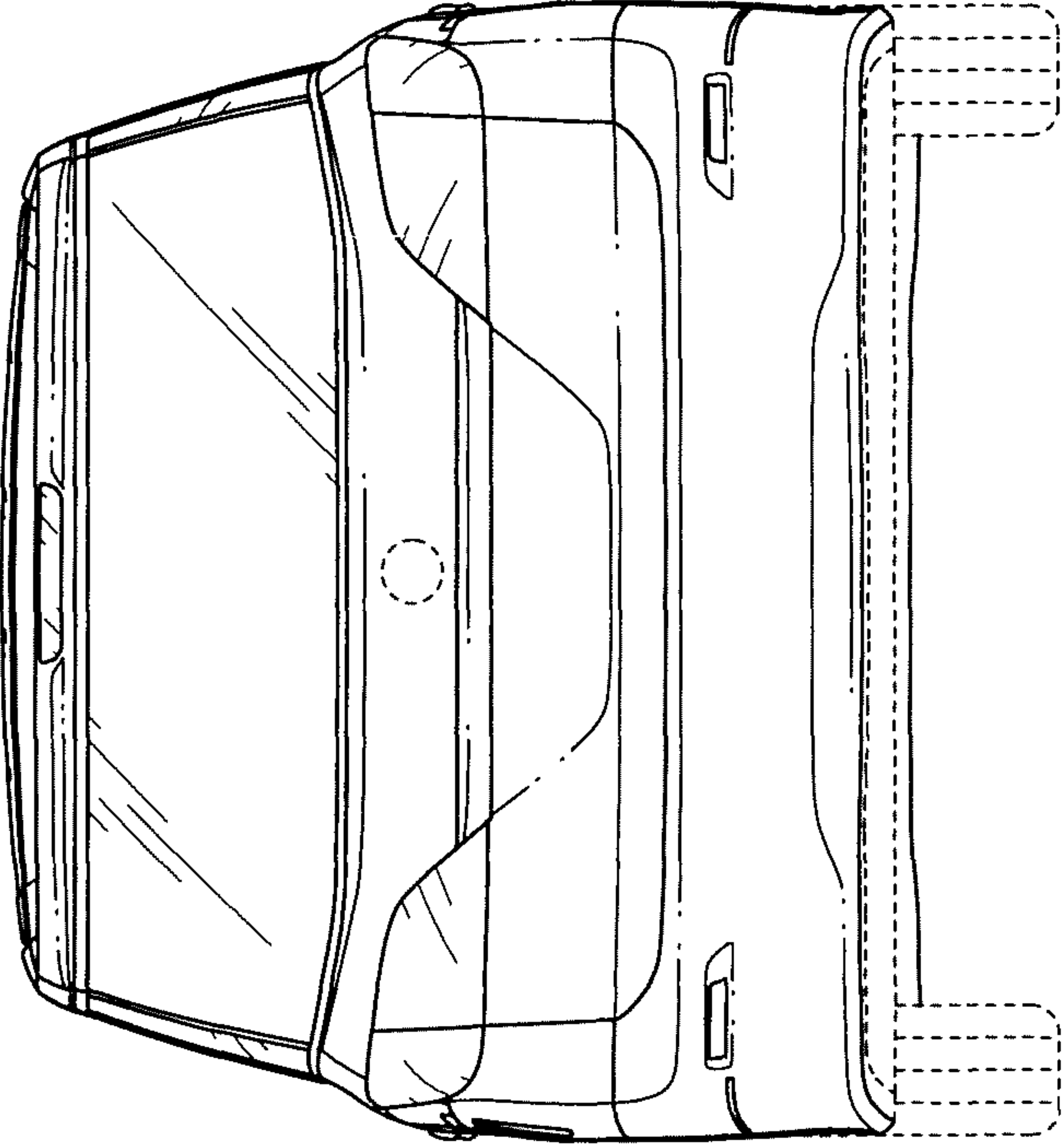

FIG. 6

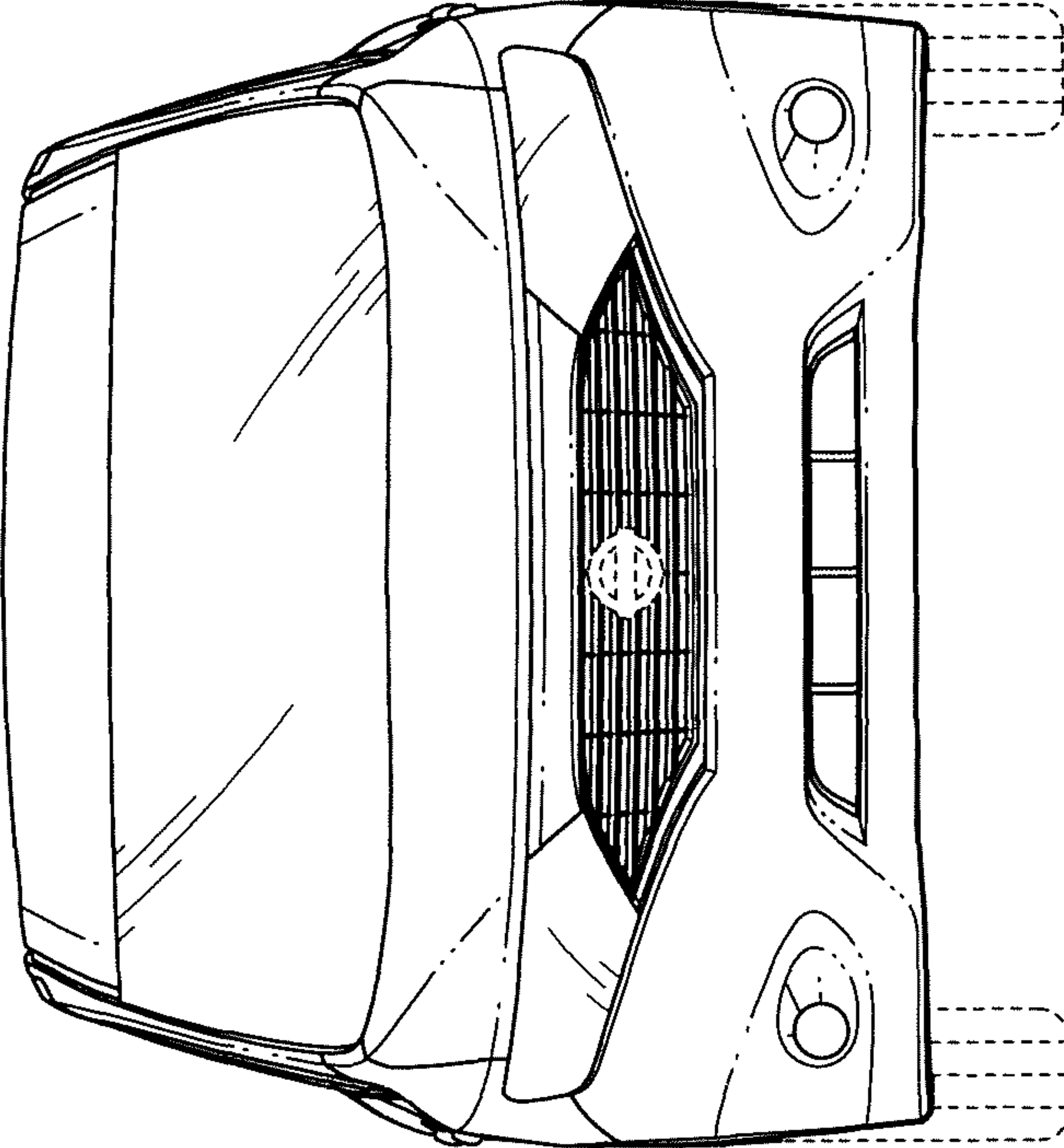

FIG. 5

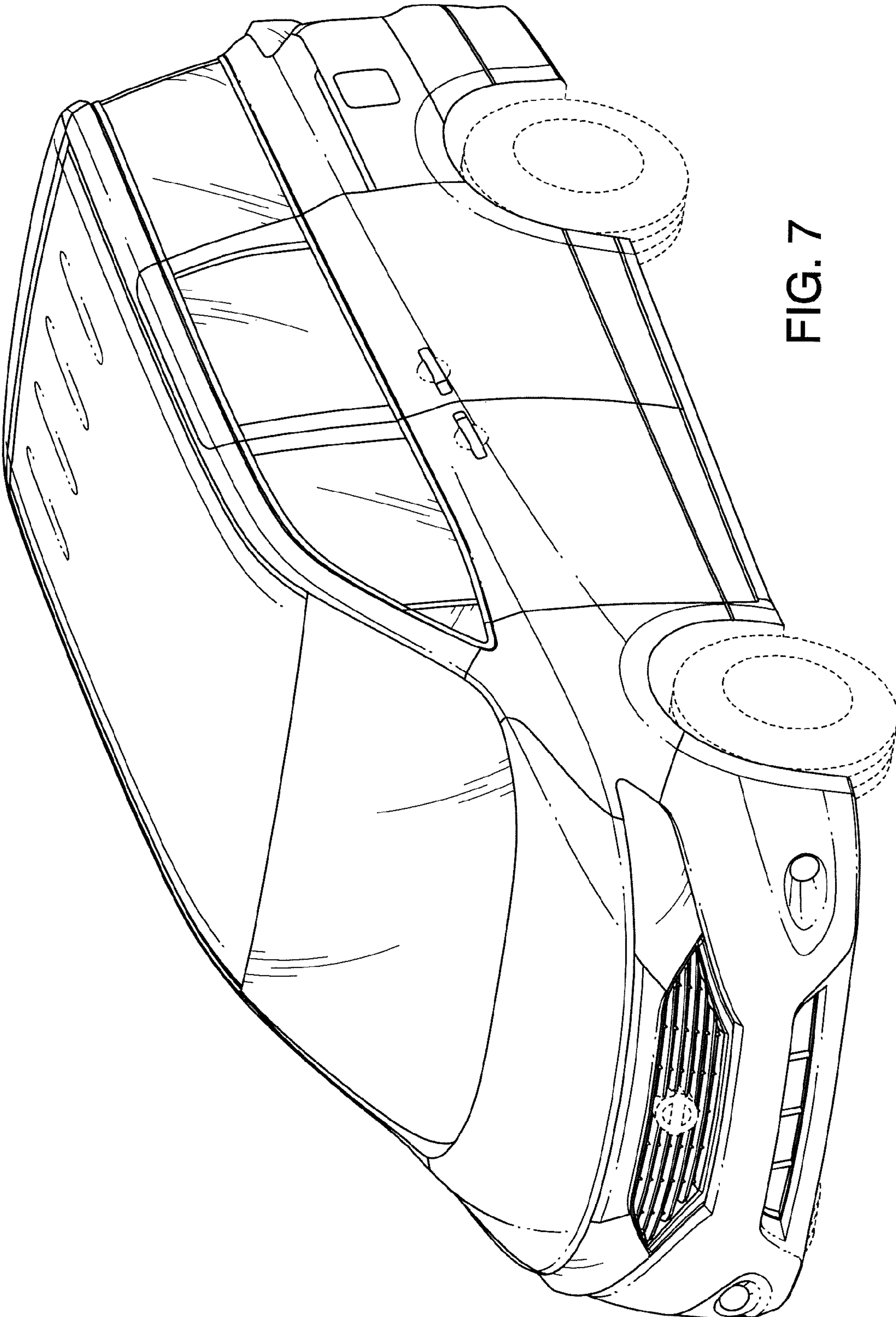

FIG. 7

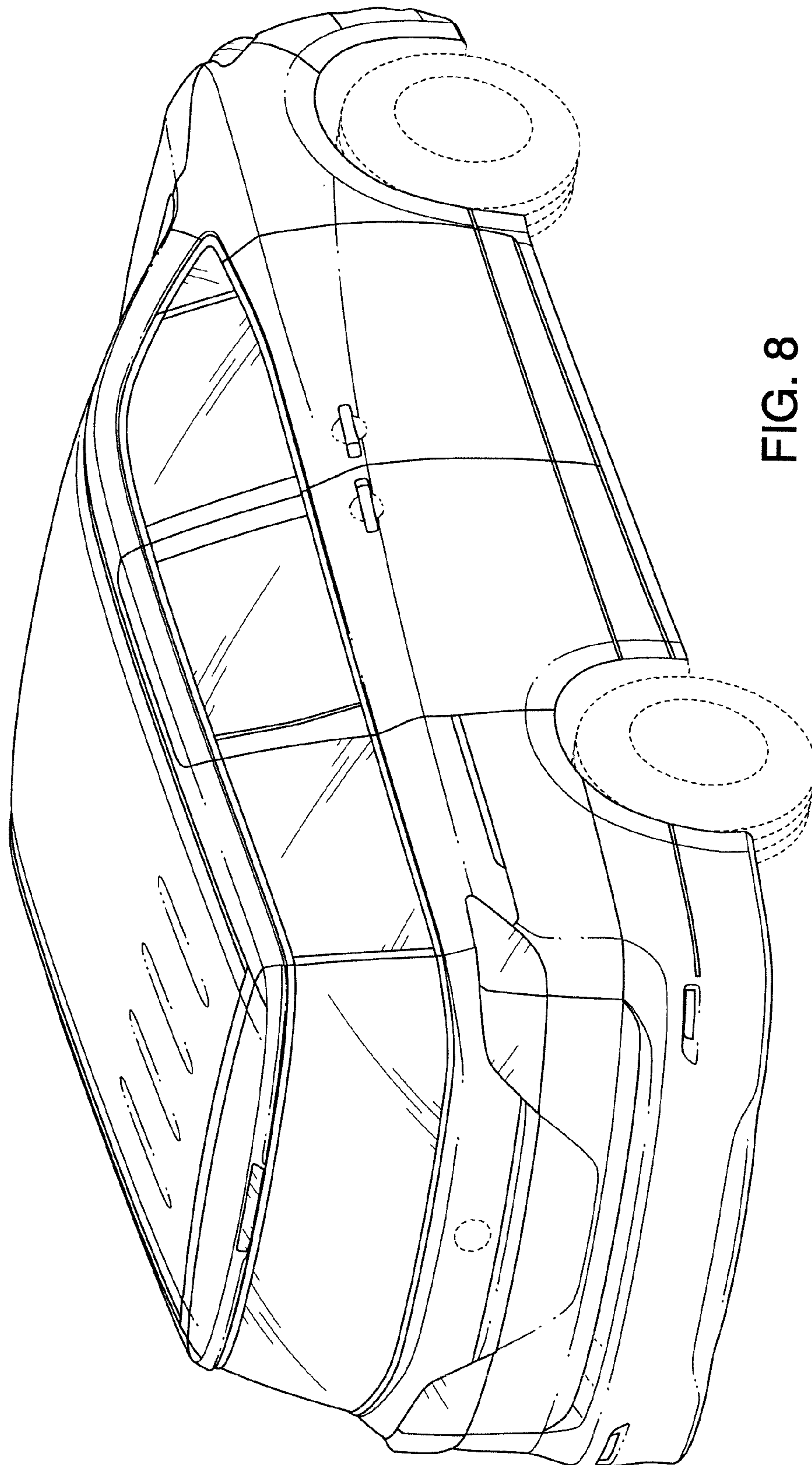

FIG. 8