



US00D631396S

(12) **United States Design Patent**
Ganassi et al.

(10) **Patent No.:** **US D631,396 S**

(45) **Date of Patent:** **** Jan. 25, 2011**

(54) **RACE CAR**

(75) Inventors: **Chip Ganassi**, Pittsburgh, PA (US);
Benjamin Bowlby, Zionsville, IN (US);
Zack Eakin, Pittsboro, IN (US); **James Hamilton**, Zionsville, IN (US)

(73) Assignee: **Delta Wing, LLC**, Indianapolis, IN (US)

(**) Term: **14 Years**

(21) Appl. No.: **29/345,558**

(22) Filed: **Oct. 19, 2009**

(51) **LOC (9) Cl.** **12-08**

(52) **U.S. Cl.** **D12/88**

(58) **Field of Classification Search** D12/86,
D12/90-92, 88, 85; D21/424, 433, 434;
296/181.1, 181.5

See application file for complete search history.

(56) **References Cited**

U.S. PATENT DOCUMENTS

D268,920 S *	5/1983	Bragdon	D12/86
D269,505 S *	6/1983	Gordon	D12/85
D274,398 S *	6/1984	Keyes	D12/85
D362,208 S *	9/1995	Gangnant	D12/86
D576,918 S *	9/2008	Taylor et al.	D12/88
D577,314 S *	9/2008	Taylor et al.	D12/88
D610,949 S *	3/2010	Tombazis	D12/88

* cited by examiner

Primary Examiner—Melody N Brown

(74) *Attorney, Agent, or Firm*—Bose, McKinney & Evans LLP

(57) **CLAIM**

The ornamental design of a race car, as shown and described.

DESCRIPTION

FIG. 1 is a perspective view of a race car showing our new design;

FIG. 2 is a side elevational view thereof;

FIG. 3 is an opposite side elevational view thereof;

FIG. 4 is a top plan view thereof;

FIG. 5 is a bottom plan view thereof;

FIG. 6 is a front elevational view thereof;

FIG. 7 is a rear elevational view thereof;

FIG. 8 is a perspective view of a race car showing second embodiment of our new design;

FIG. 9 is a side elevational view of FIG. 8;

FIG. 10 is an opposite side elevational view of FIG. 8;

FIG. 11 is a top plan view of FIG. 8;

FIG. 12 is a bottom plan view of FIG. 8;

FIG. 13 is a front elevational view of FIG. 8; and,

FIG. 14 is a rear elevational view of FIG. 8.

1 Claim, 12 Drawing Sheets

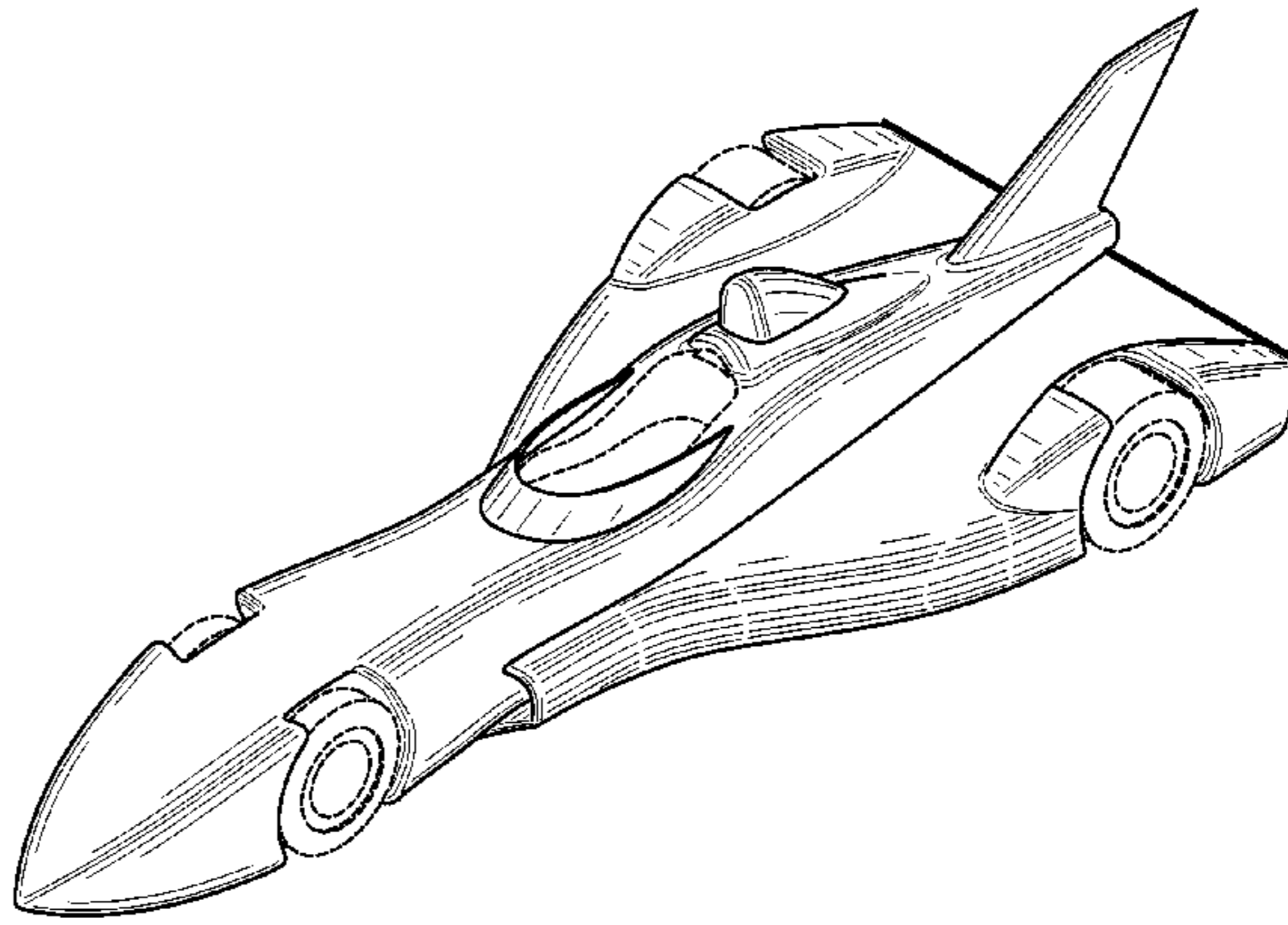
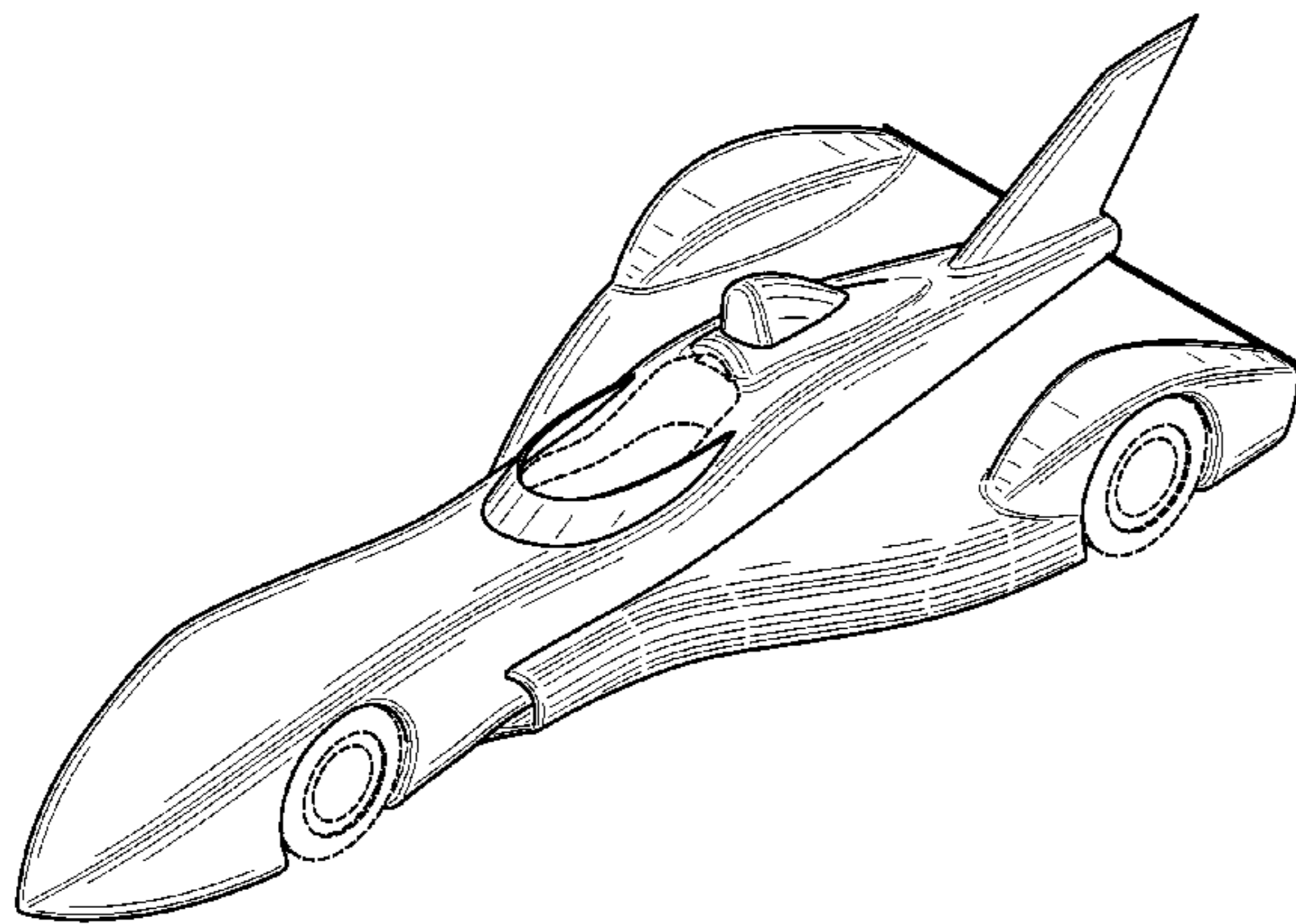

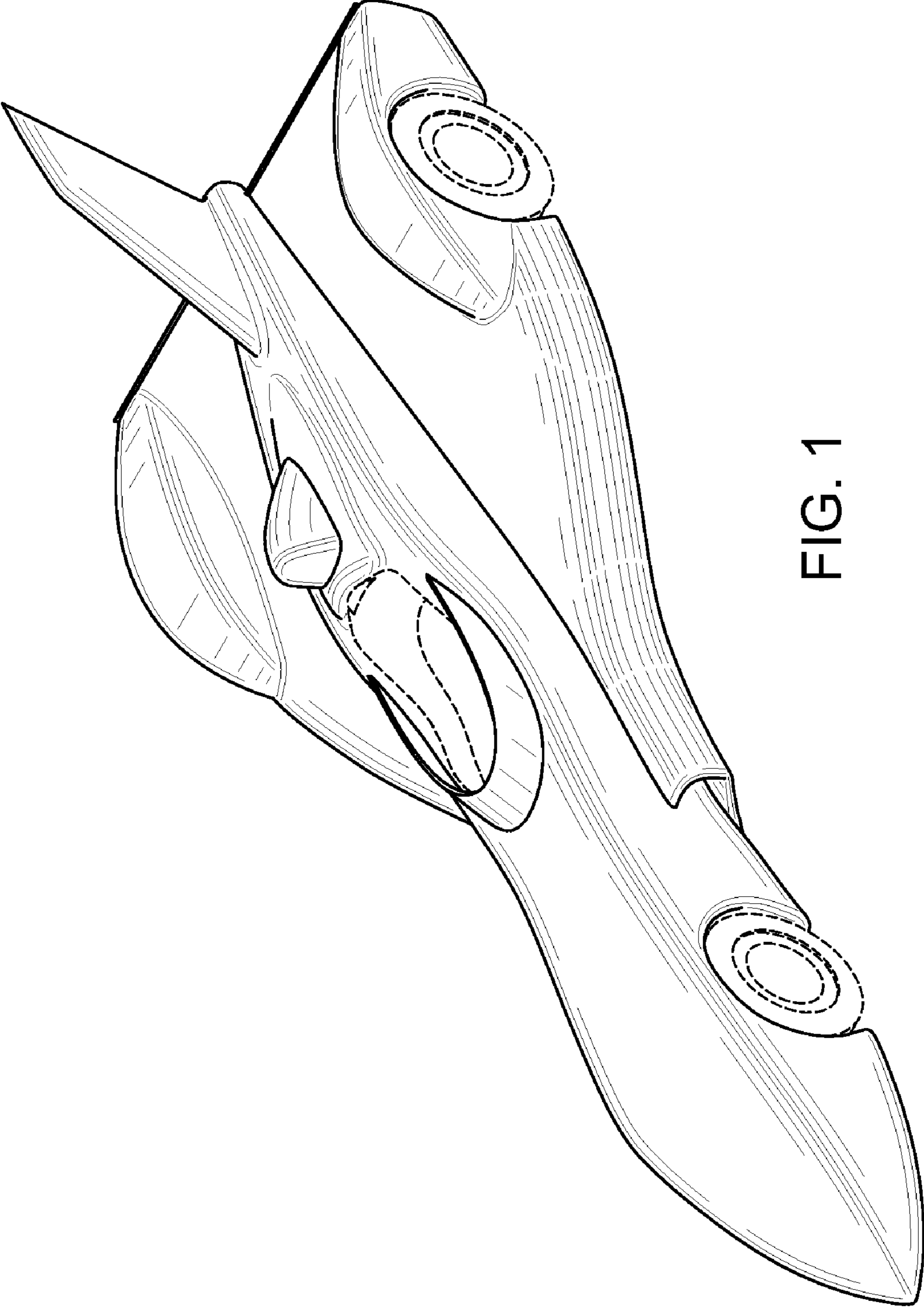

FIG. 1

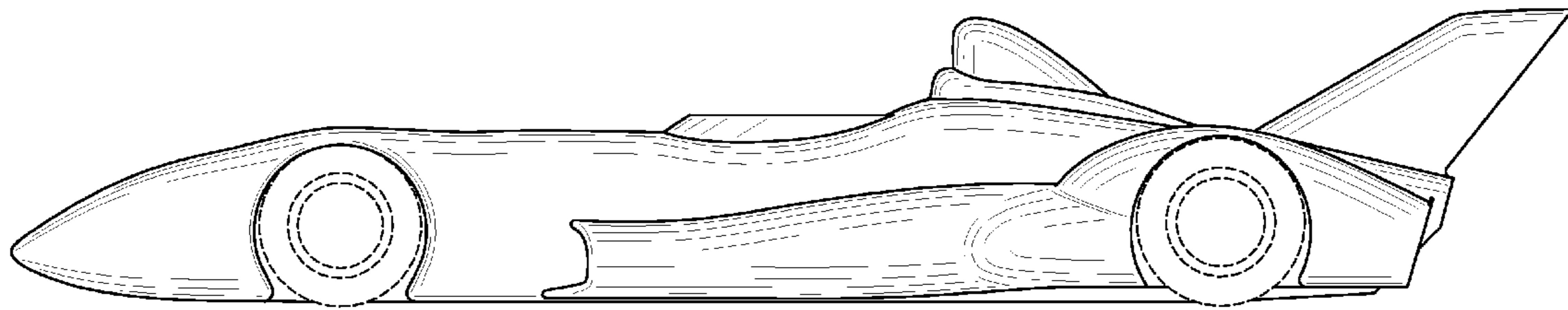

FIG. 2

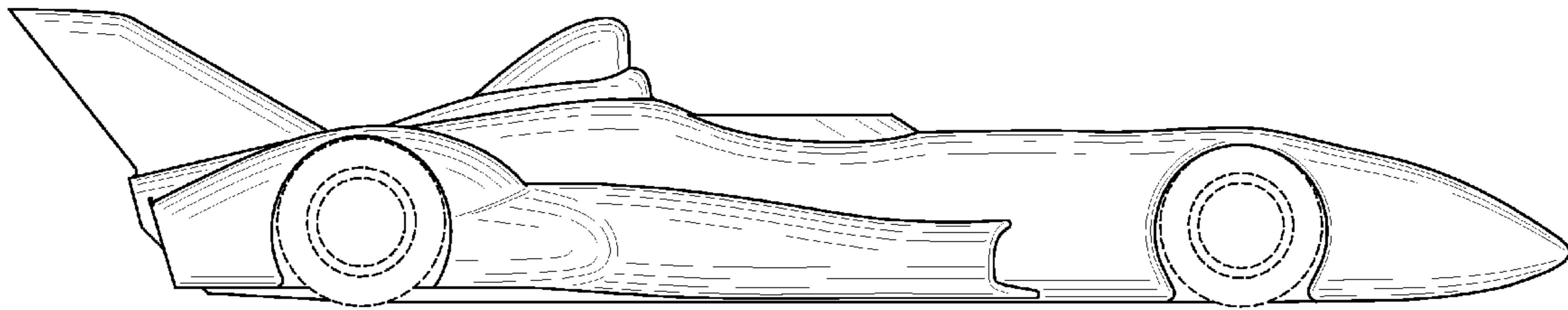

FIG. 3

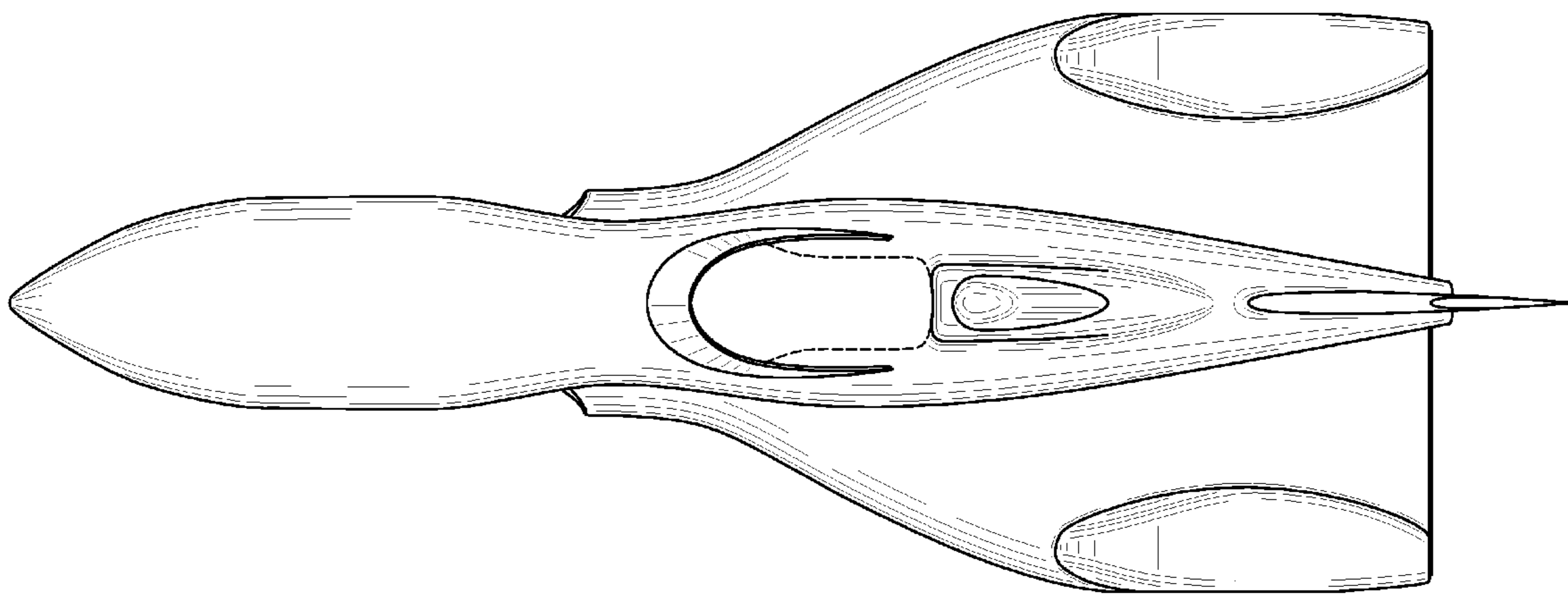

FIG. 4

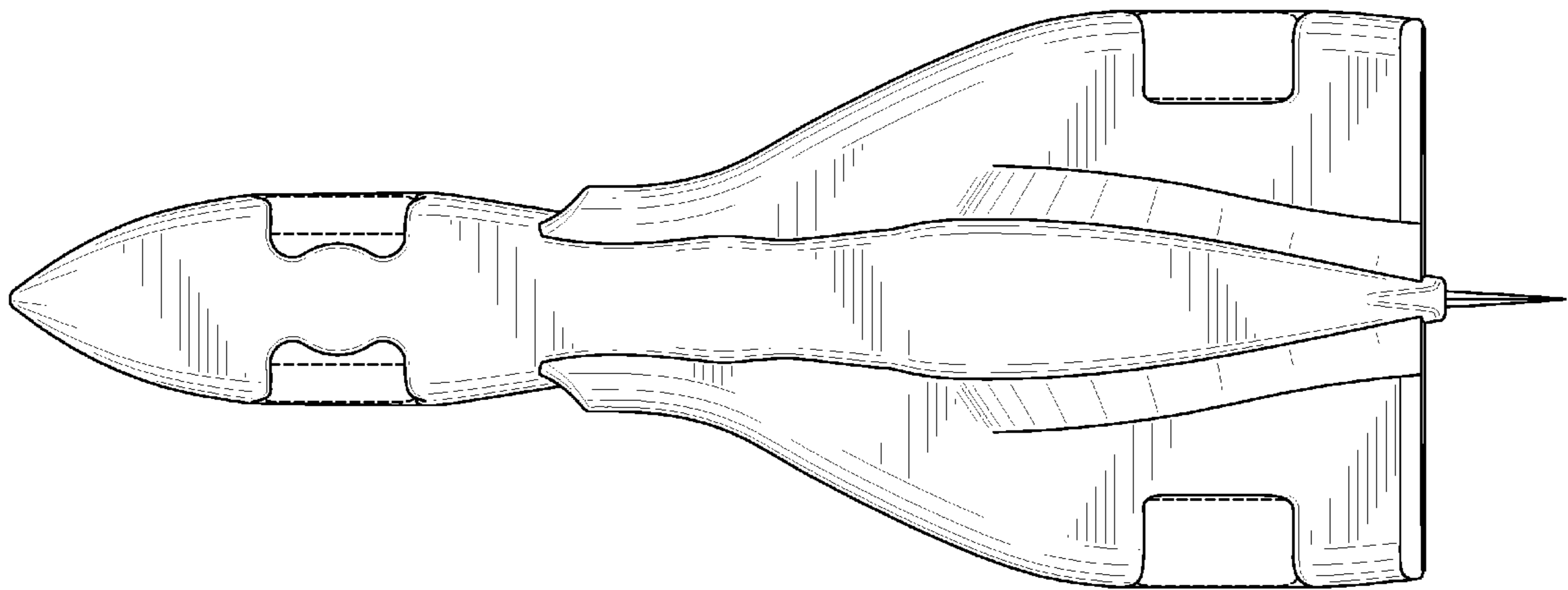

FIG. 5

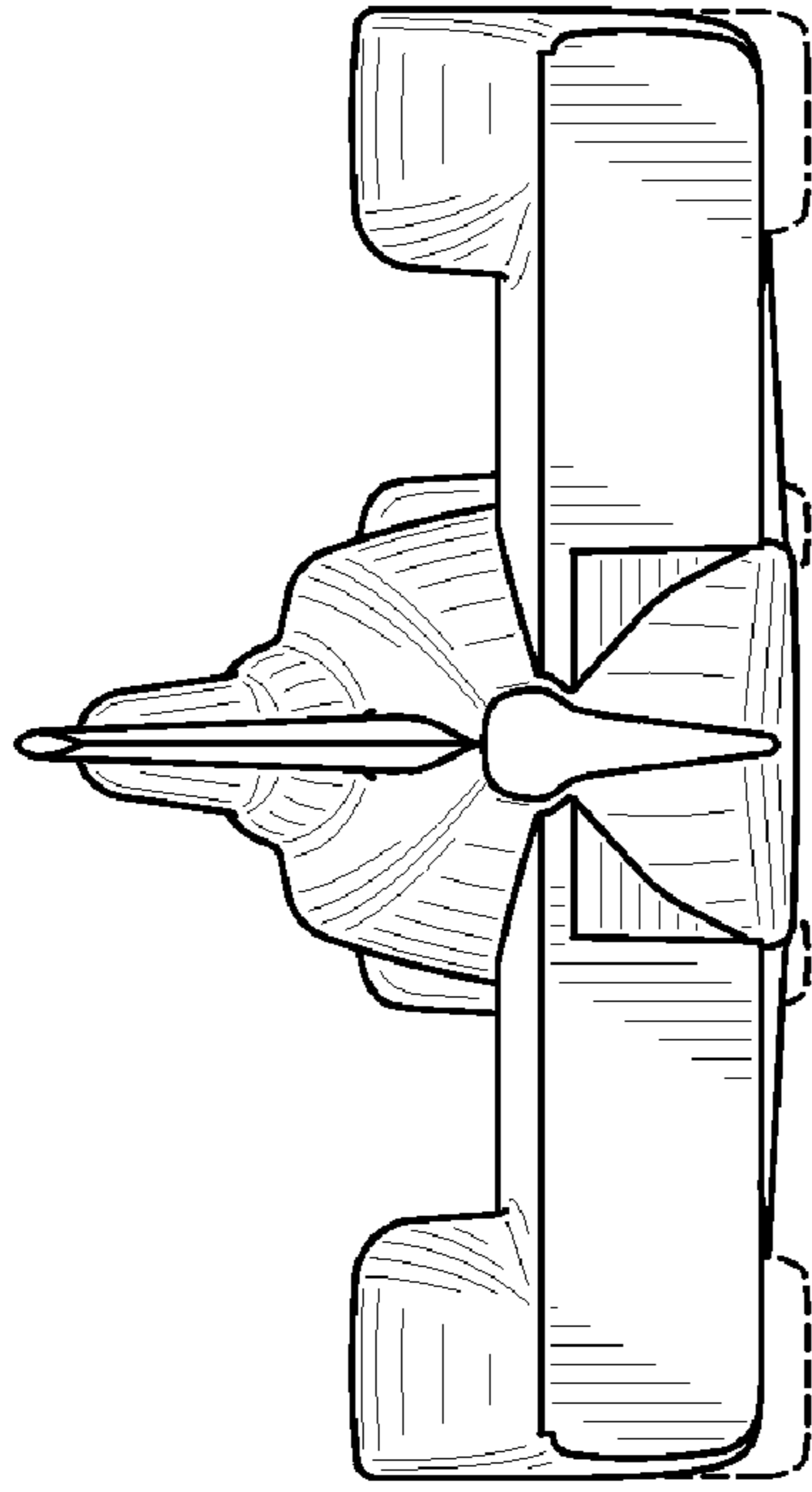

FIG. 7

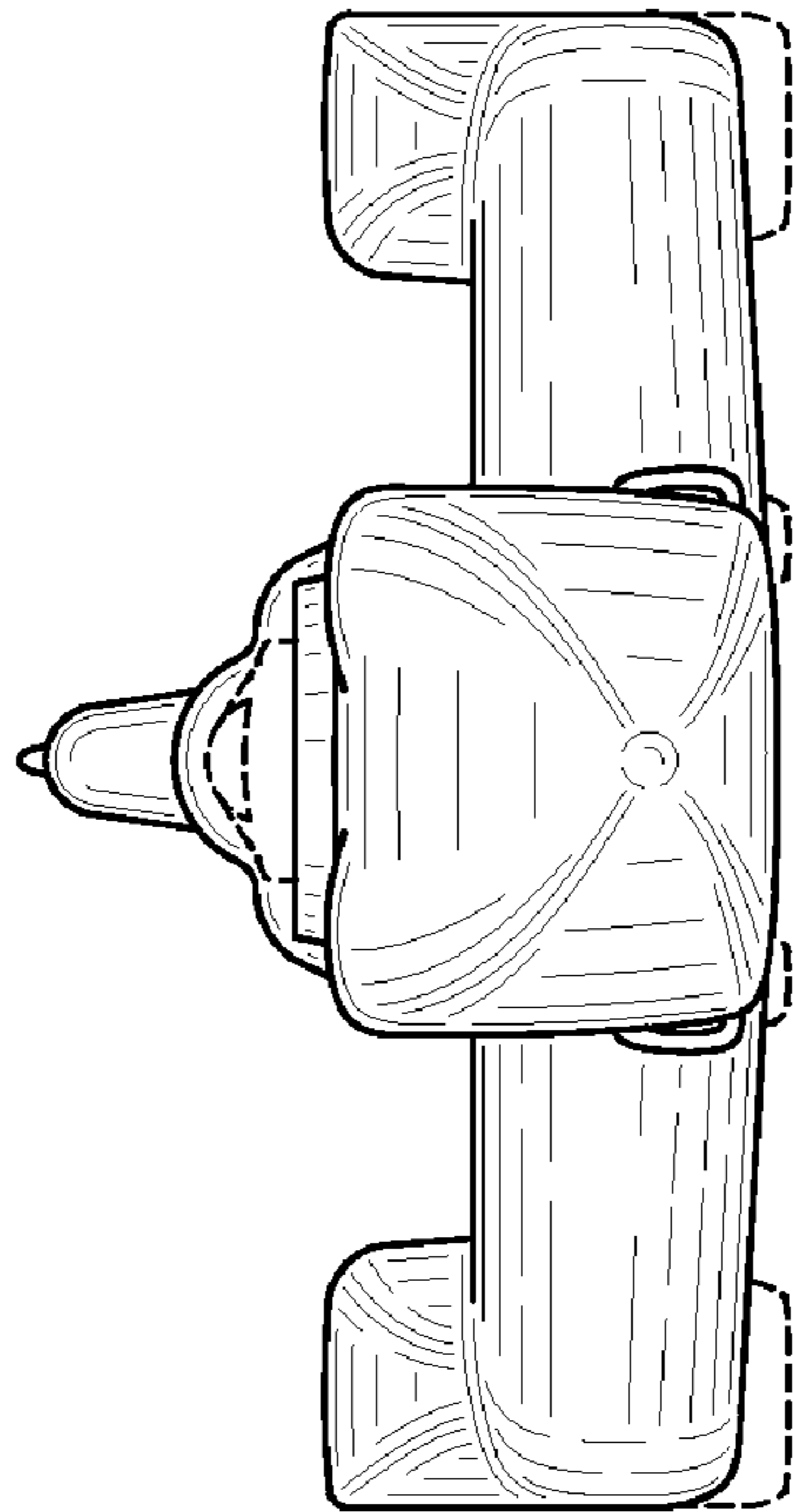

FIG. 6

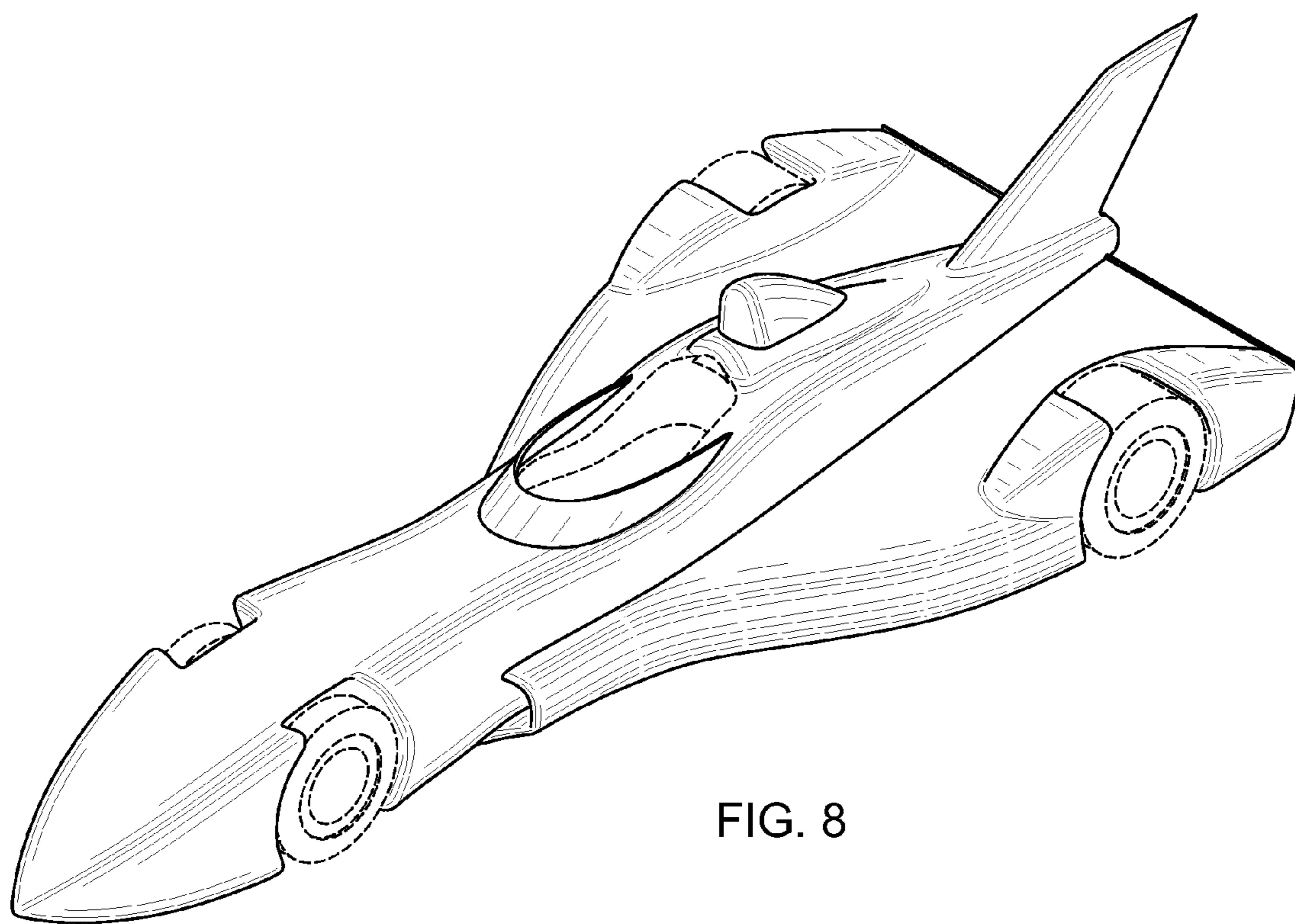

FIG. 8

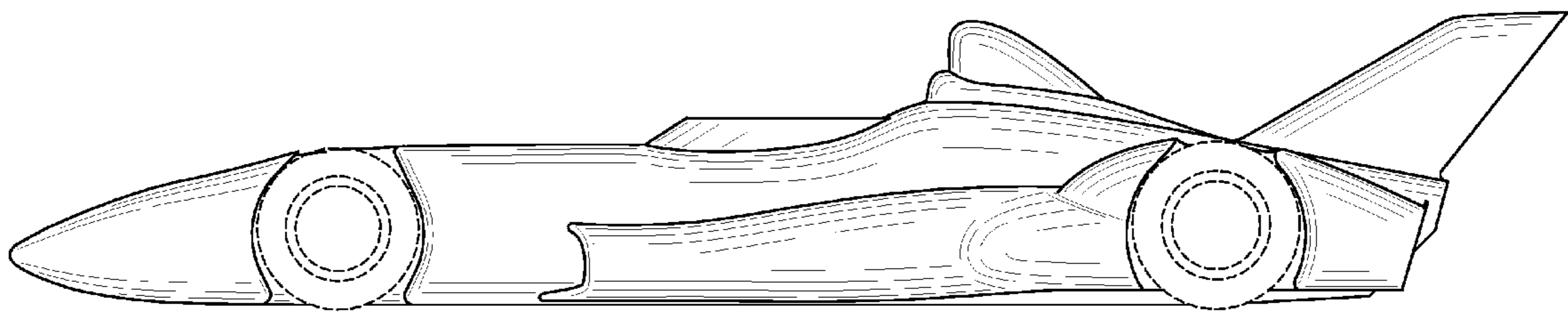

FIG. 9

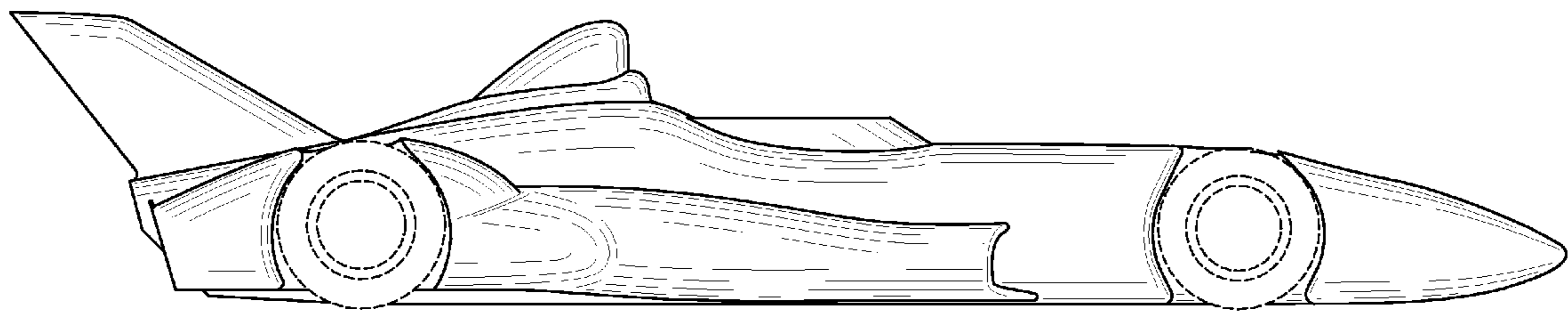

FIG. 10

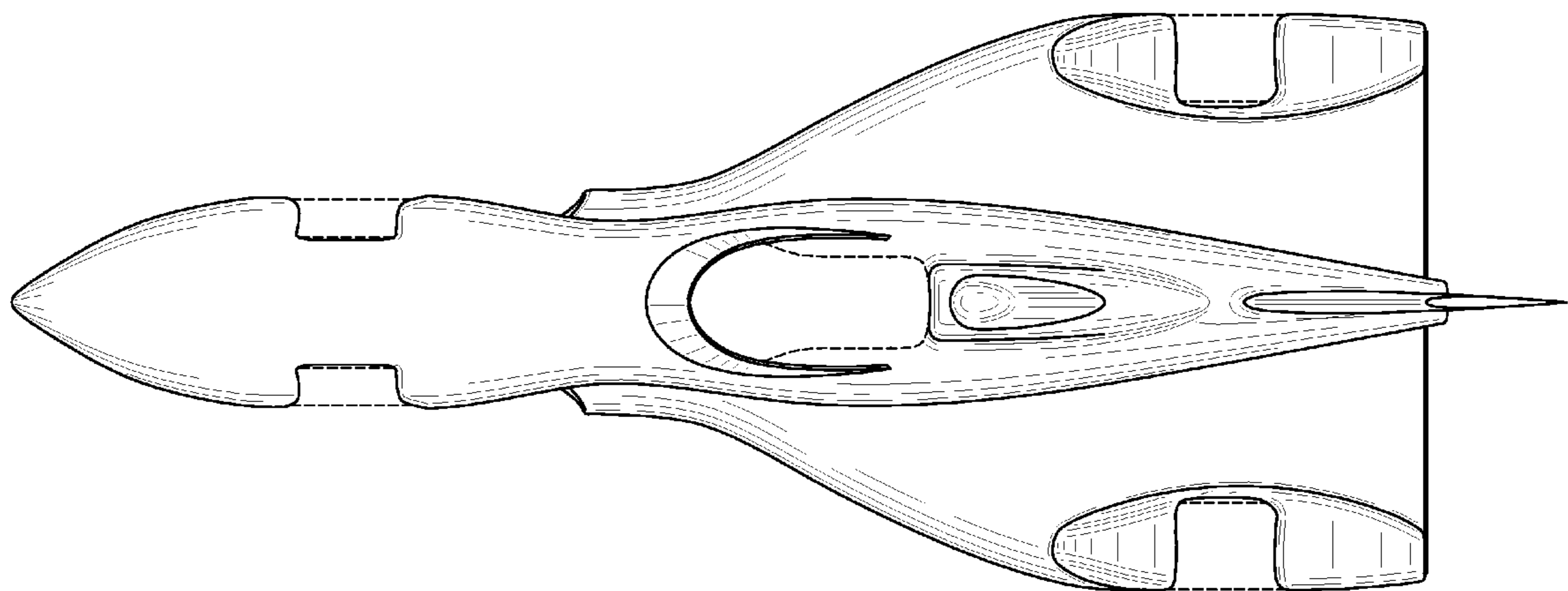

FIG. 11

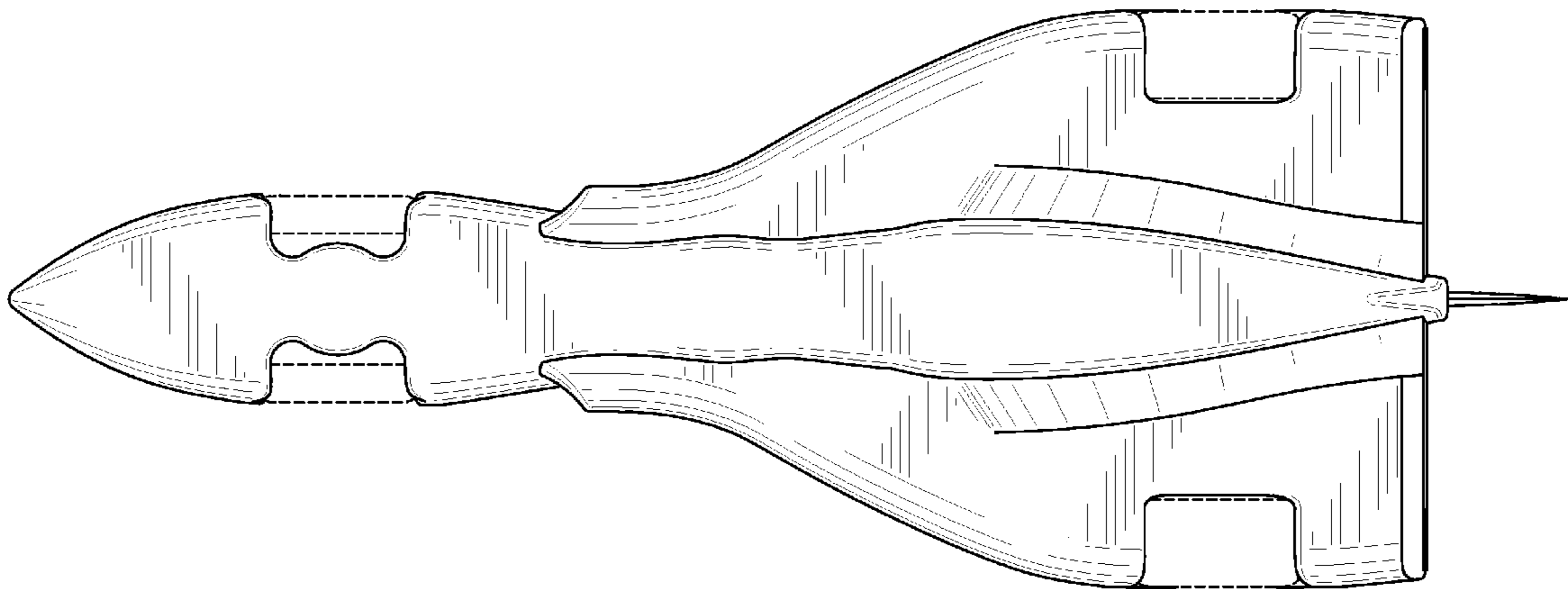

FIG. 12

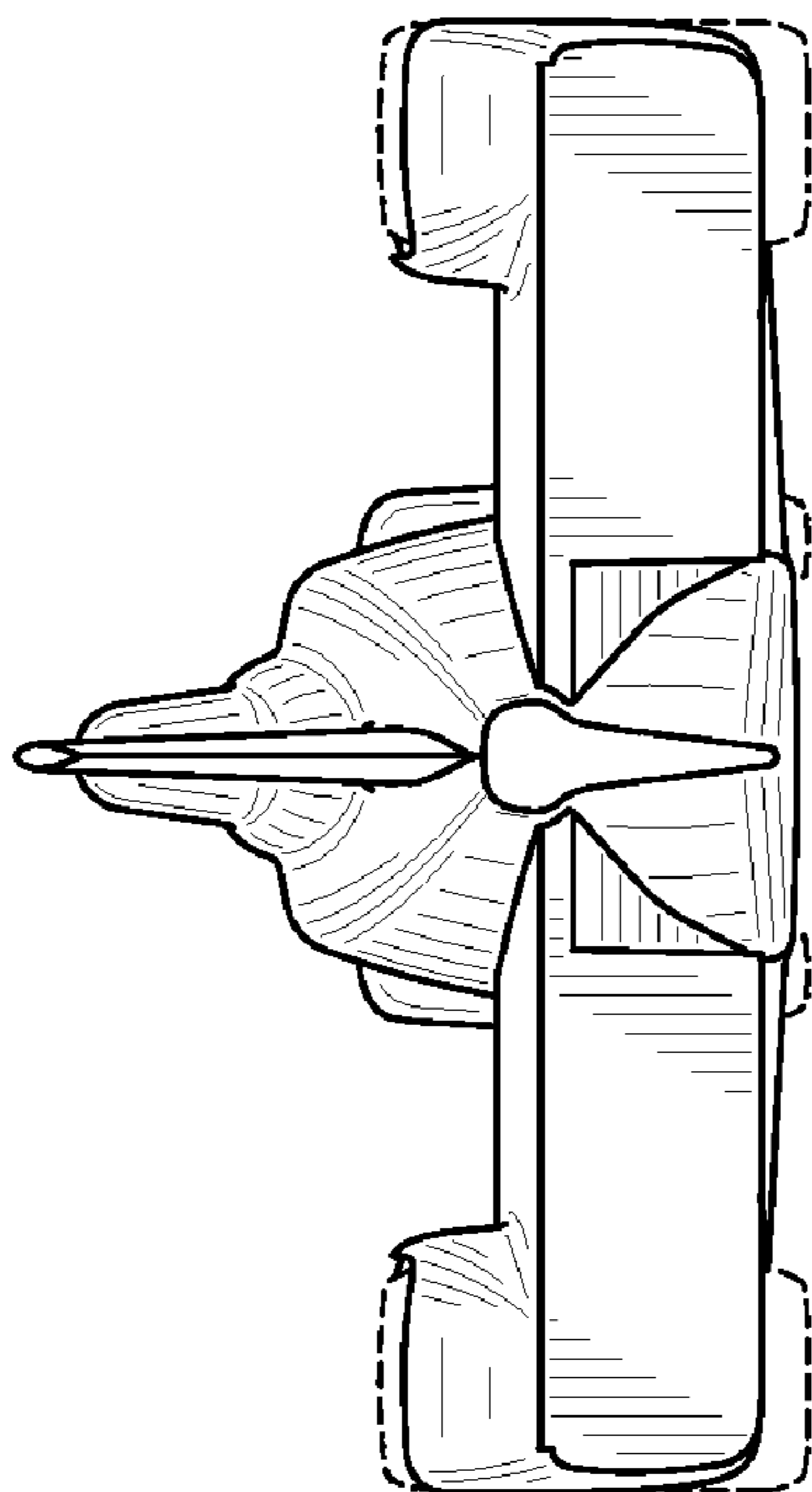

FIG. 14

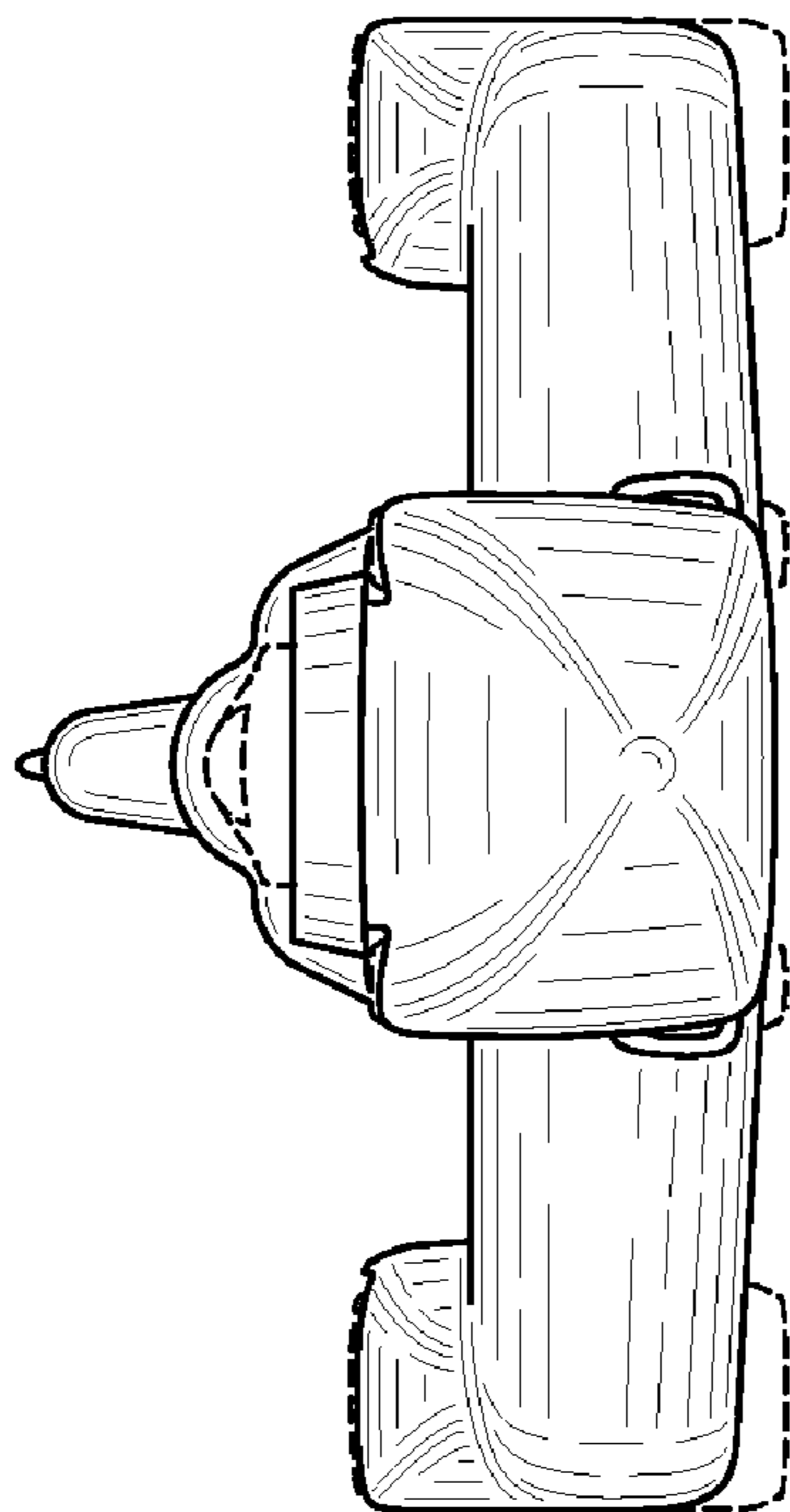

FIG. 13