



US00D631329S

(12) **United States Design Patent**
Richards

(10) **Patent No.:** **US D631,329 S**
(45) **Date of Patent:** **** Jan. 25, 2011**

(54) **ADJUSTABLE PAPER AND CABLE
RETAINER**

(76) Inventor: **Donna Eaton Richards**, 889 Highridge
St., Riverside, CA (US) 82506

(**) Term: **14 Years**

(21) Appl. No.: **29/362,172**

(22) Filed: **May 20, 2010**

Related U.S. Application Data

(63) Continuation-in-part of application No. 29/336,325,
filed on Apr. 30, 2009.

(51) **LOC (9) Cl.** **08-06**

(52) **U.S. Cl.** **D8/356**

(58) **Field of Classification Search** D8/105,
D8/107, 333, 349, 354, 356, 358, 360, 360.1,
D8/367, 372, 373, 382, 383, 394-396, 400;
D13/133, 139.4, 153, 155; 24/18, 20 W,
24/23 W, 115 R, 129 C, 130, 131 R, 197,
24/561; 52/220.7; 174/72 A, 100, 135, 153 G,
174/650, 656; 211/86.01, 87.01, 94.01;
242/400.1, 405.1, 405.2, 600, 603; 248/65,
248/74.1-74.4, 201, 214, 215, 229.26

See application file for complete search history.

(56) **References Cited**

U.S. PATENT DOCUMENTS

| | | | |
|---------------|---------|-----------------|---------|
| 546,484 A | 9/1895 | Brown | |
| 902,189 A | 10/1908 | Wheildon | |
| 1,945,932 A * | 2/1934 | Caley | 132/247 |
| 2,099,881 A | 11/1937 | Emmer | |
| 2,773,504 A | 12/1956 | McGervey | |
| 3,205,897 A | 9/1965 | Jamison | |
| 3,467,479 A | 9/1969 | Holes et al. | |
| 3,501,814 A | 3/1970 | Anderson et al. | |
| 3,516,124 A | 6/1970 | Merser | |
| 3,881,334 A | 5/1975 | Wilson | |
| 3,908,909 A | 9/1975 | Kaatz | |
| D252,741 S | 8/1979 | Taylor | |
| D273,841 S | 5/1984 | Chace | |

| | | | |
|-----------------|---------|------------------|----------|
| 4,492,004 A | 1/1985 | Oetiker | |
| 4,572,466 A * | 2/1986 | Yamaguchi et al. | 248/73 |
| 4,693,624 A | 9/1987 | Moosmuller | |
| 4,919,373 A * | 4/1990 | Caveney et al. | 248/74.3 |
| 4,932,804 A | 6/1990 | Richards | |
| 4,942,644 A | 7/1990 | Rowley | |
| D313,547 S | 1/1991 | Buckles | |
| 5,054,816 A | 10/1991 | Rosengarten | |
| 5,156,644 A | 10/1992 | Koehler et al. | |
| 5,172,879 A | 12/1992 | Calmettes et al. | |
| 5,423,624 A | 6/1995 | Richards | |
| D363,877 S | 11/1995 | Dee | |
| D368,652 S | 4/1996 | Stanley | |
| D370,407 S | 6/1996 | Pietrowski | |
| D400,686 S | 11/1998 | Hamerman | |
| D424,566 S | 5/2000 | Baker | |
| 6,192,554 B1 | 2/2001 | Dumcum | |
| 6,386,489 B1 | 5/2002 | Gretz | |
| 6,481,061 B1 | 11/2002 | Andre et al. | |
| 6,523,229 B2 | 2/2003 | Severson | |
| 6,747,209 B2 * | 6/2004 | Uchida et al. | 174/68.1 |
| 7,198,442 B2 | 4/2007 | Waldron | |
| 7,377,013 B2 | 5/2008 | Cheung | |
| 7,404,238 B2 | 7/2008 | McNeill | |
| 2009/0106948 A1 | 4/2009 | Lopez et al. | |

* cited by examiner

Primary Examiner—Robert M Spear

Assistant Examiner—Karen Acker

(74) *Attorney, Agent, or Firm*—Kirk A. Buhler; Buhler &
Associates

(57) **CLAIM**

The ornamental design for an adjustable paper and cable
retainer, as shown and described.

DESCRIPTION

FIG. 1 is a top perspective view for an adjustable paper and
cable retainer showing my new design;

FIG. 2 is an enlarged perspective detail view of the head
portion thereof

FIG. 3 is an enlarged perspective detail view of the tail portion
thereof;

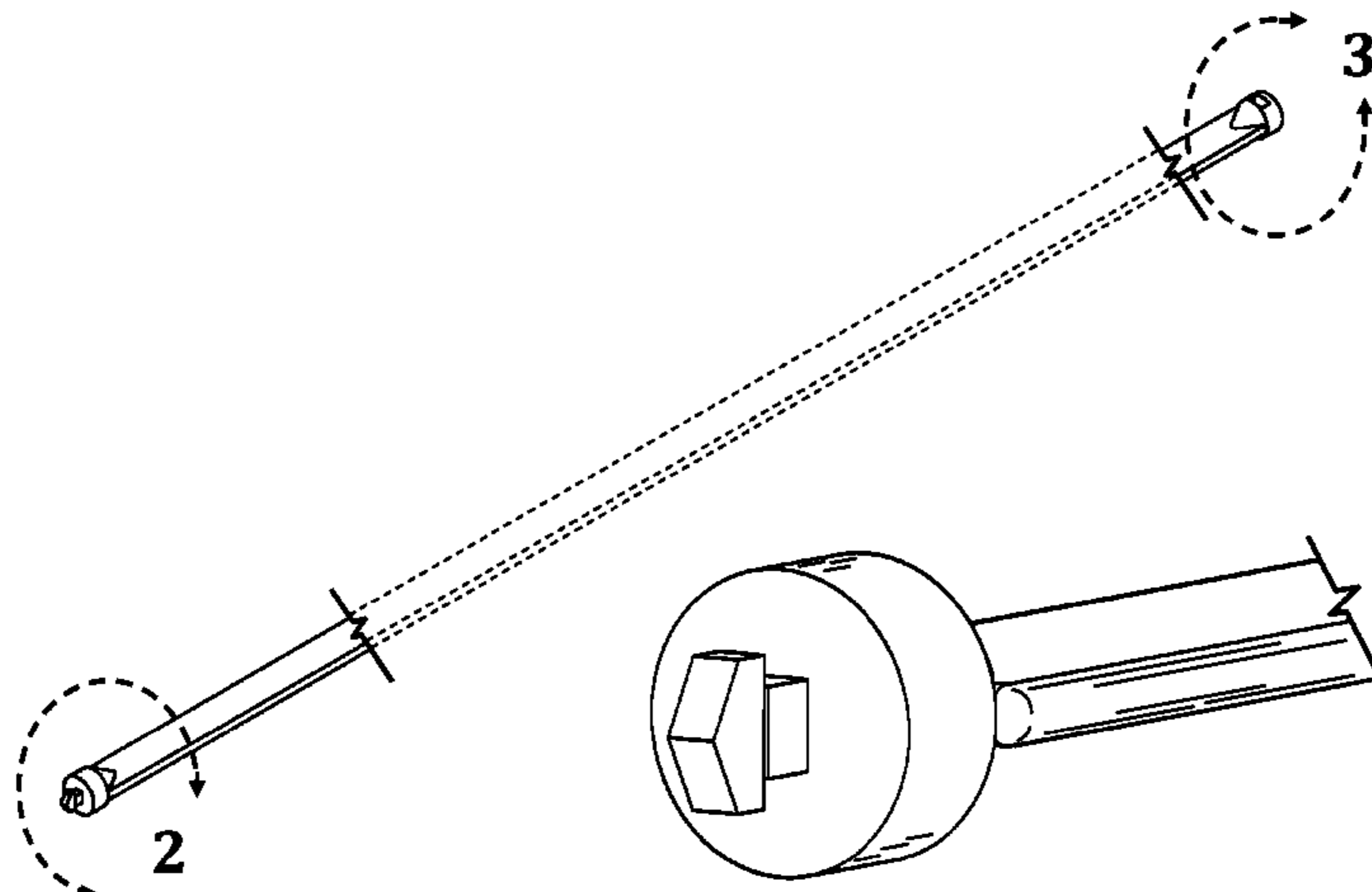

FIG. 4 is a right detail view of the head portion where the left detail view is a mirror image thereof;

FIG. 5 is a front detail view of the head portion where the back detail view is a mirror image thereof;

FIG. 6 is a top thereof;

FIG. 7 is a right detail view of the tail portion thereof;

FIG. 8 is a front detail view of the tail portion where the back detail view is a mirror image thereof;

FIG. 9 is a bottom thereof;

FIG. 10 is a right side of a first embodiment thereof;

FIG. 11 is a front side of a first embodiment thereof;

FIG. 12 is a left side of a first embodiment thereof;

FIG. 13 is a back side of a first embodiment thereof;

FIG. 14 is a right side of a second embodiment thereof;

FIG. 15 is a front side of a second embodiment thereof;

FIG. 16 is a left side of a second embodiment thereof;

FIG. 17 is a back side of a second embodiment thereof;

FIG. 18 is a right side of a third embodiment thereof;

FIG. 19 is a front side of a third embodiment thereof;

FIG. 20 is a left side of a third embodiment thereof;

FIG. 21 is a back side of a third embodiment thereof;

FIG. 22 is a right side of a fourth embodiment thereof;

FIG. 23 is a front side of a fourth embodiment thereof;

FIG. 24 is a left side of a fourth embodiment thereof;

FIG. 25 is a back side of a fourth embodiment thereof;

FIG. 26 is a right side of a fifth embodiment thereof;

FIG. 27 is a front side of a fifth embodiment thereof;

FIG. 28 is a left side of a fifth embodiment thereof;

FIG. 29 is a back side of a fifth embodiment thereof;

FIG. 30 is a right side of a sixth embodiment thereof;

FIG. 31 is a front side of a sixth embodiment thereof;

FIG. 32 is a left side of a sixth embodiment thereof; and,

FIG. 33 is a back side of a sixth embodiment thereof.

FIGS. 1 through 9 are perspective and detail views for all embodiments. The break lines in FIGS. 2 through 5 and FIGS. 7 and 8 represent the boundary of the details shown in broken line in FIG. 1. The broken lines form no part of the claimed design.

1 Claim, 8 Drawing Sheets

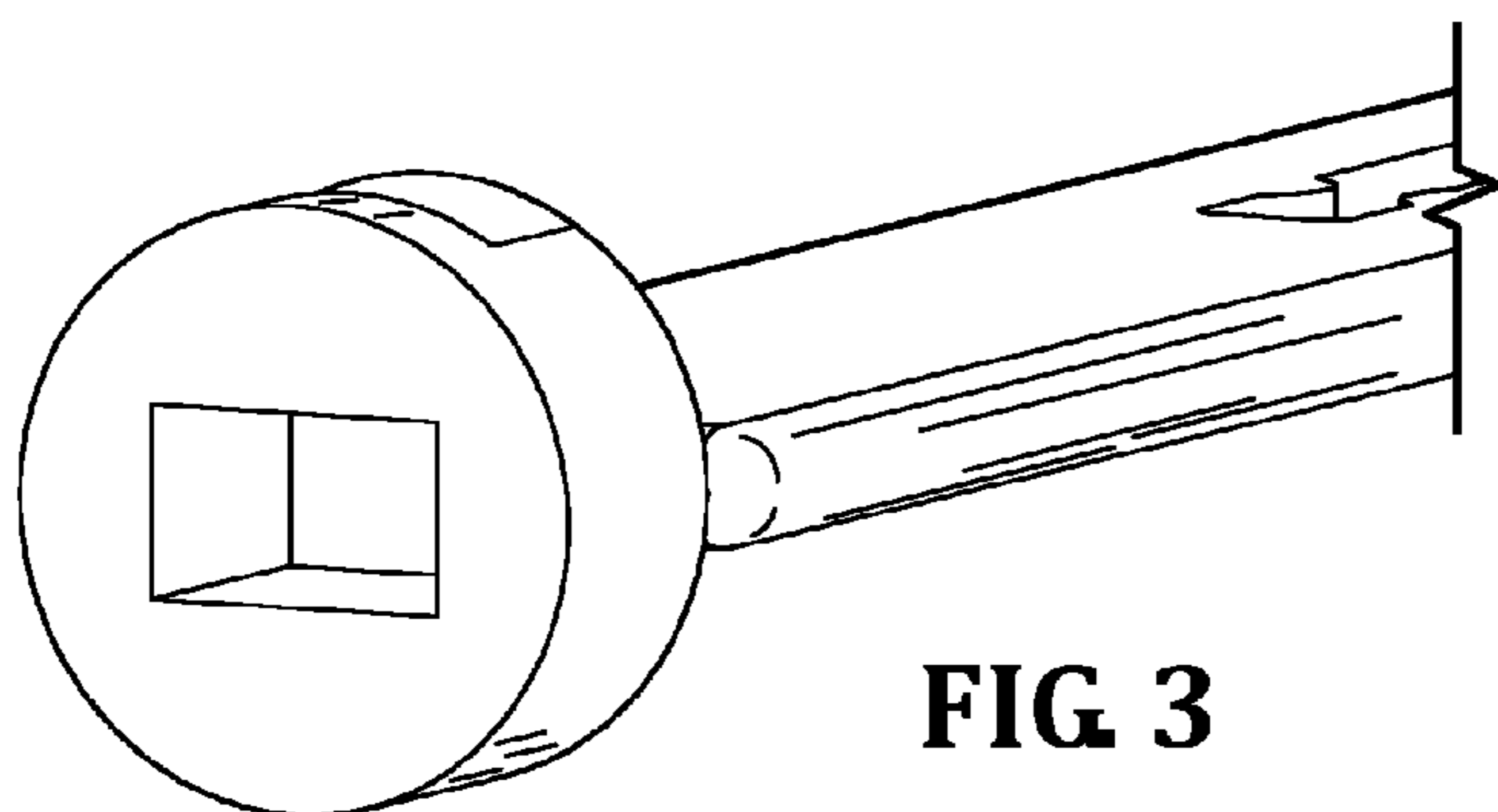
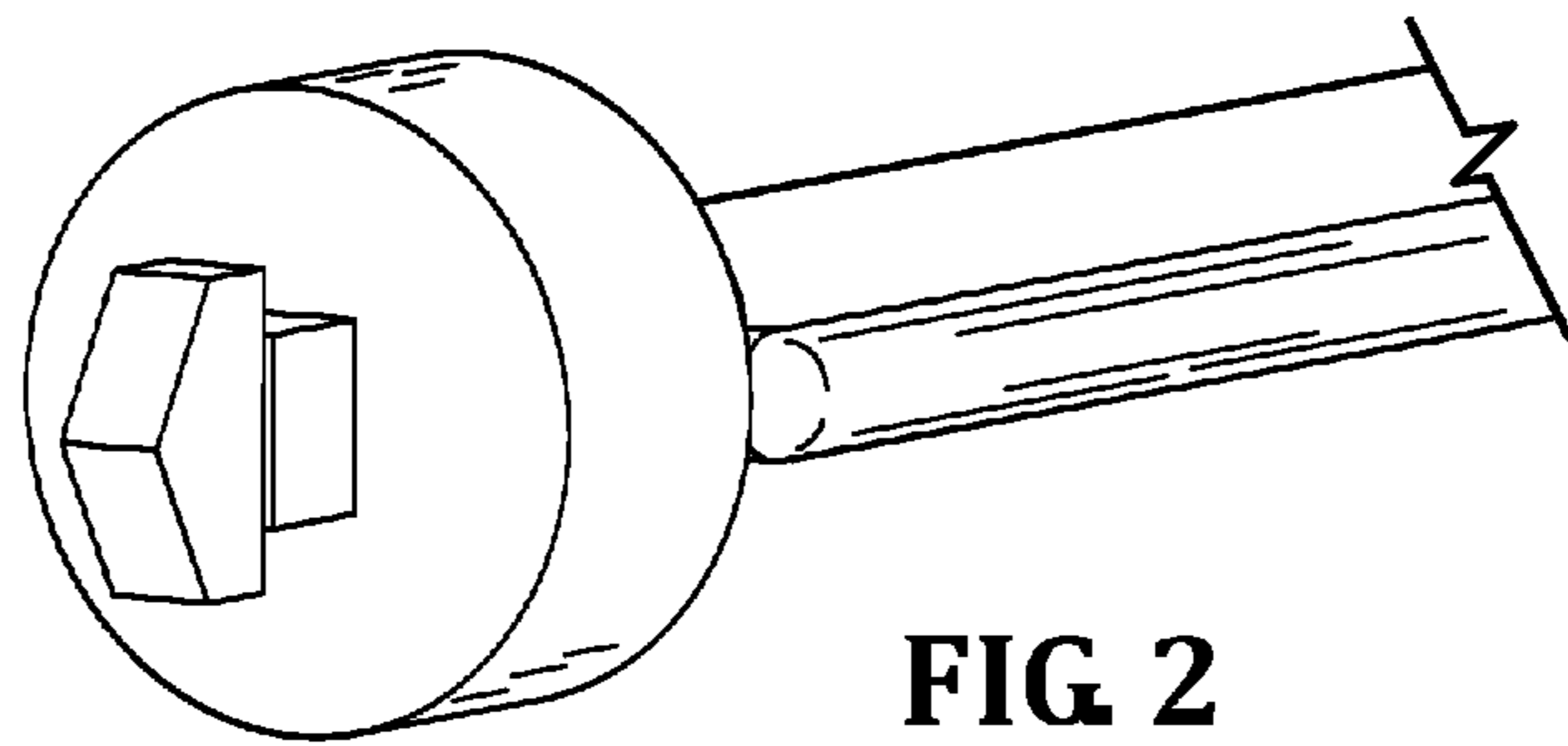
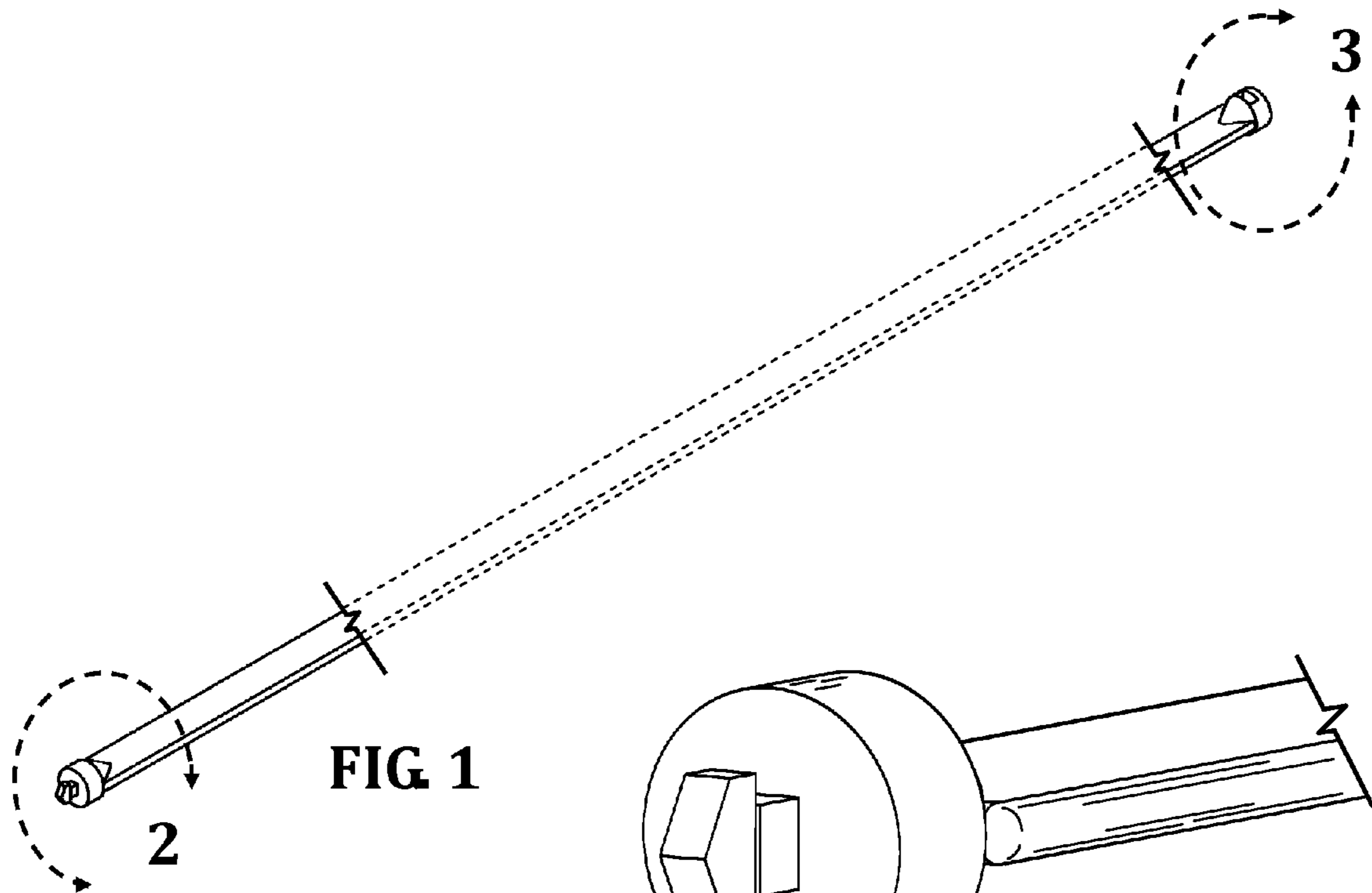

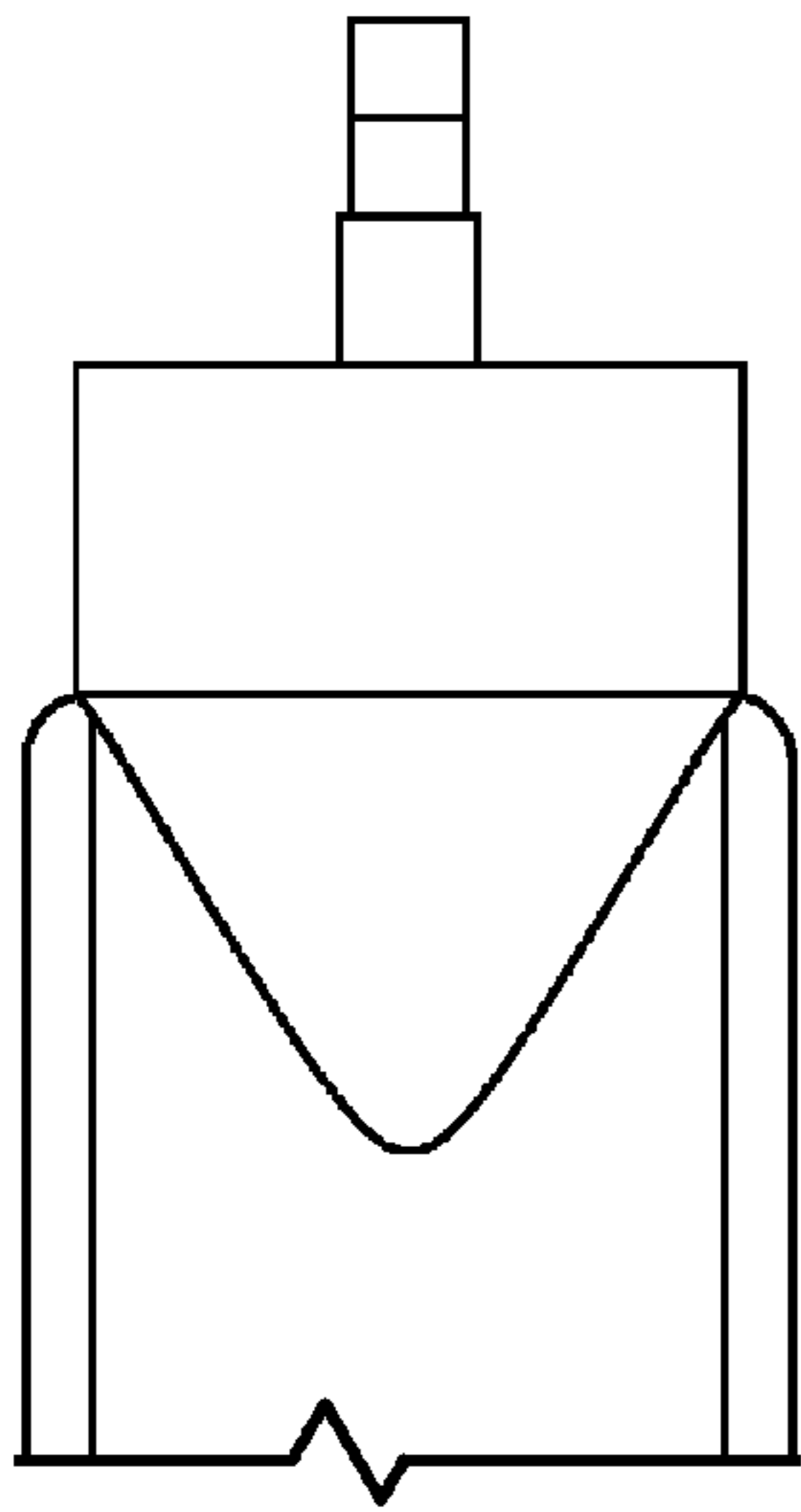

FIG. 4

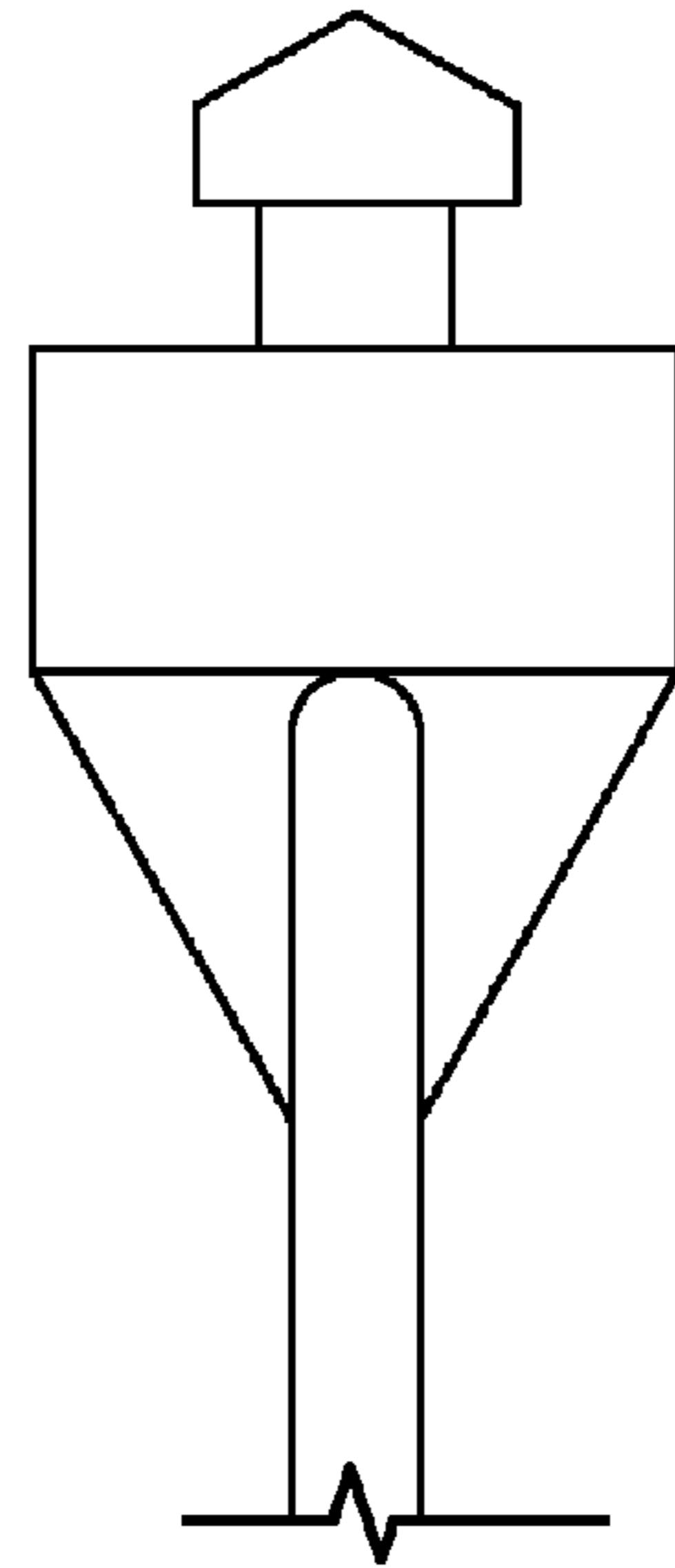

FIG. 5

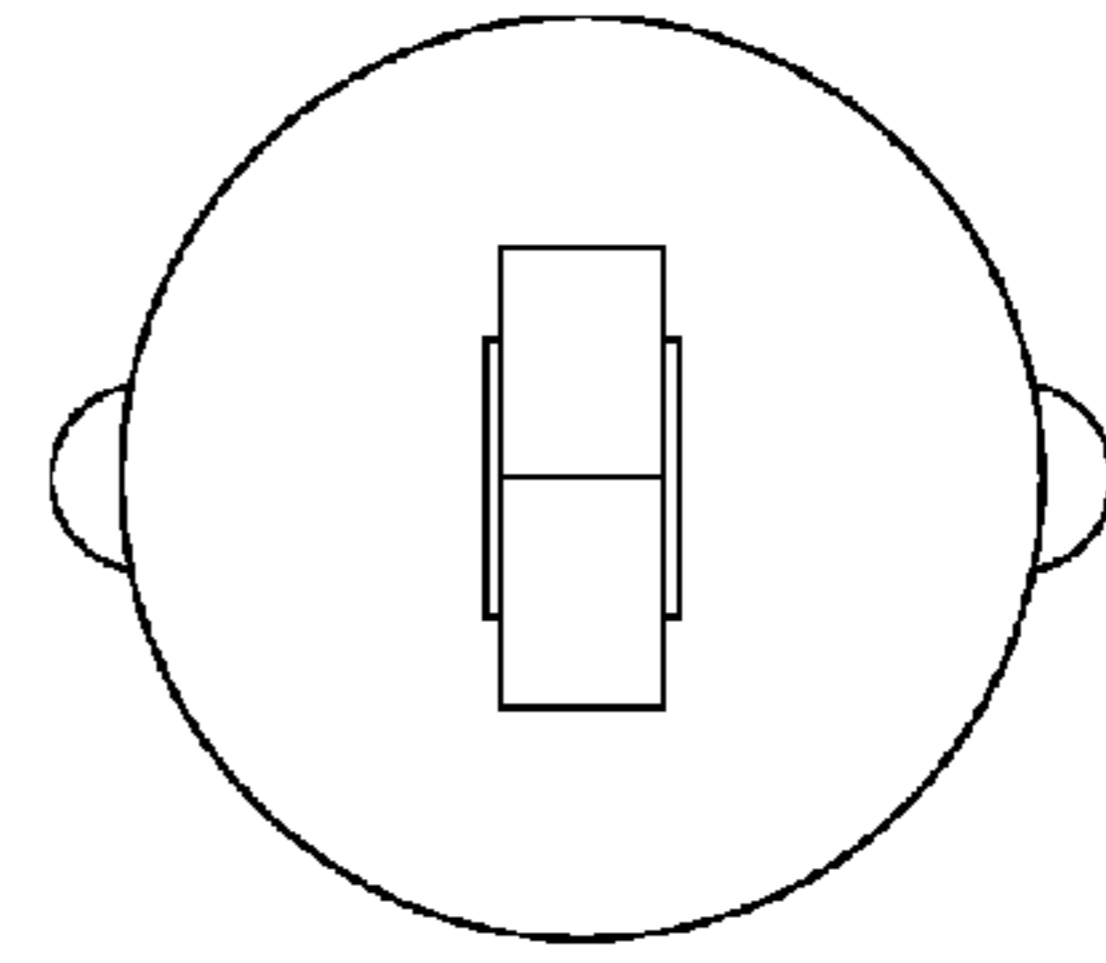

FIG. 6

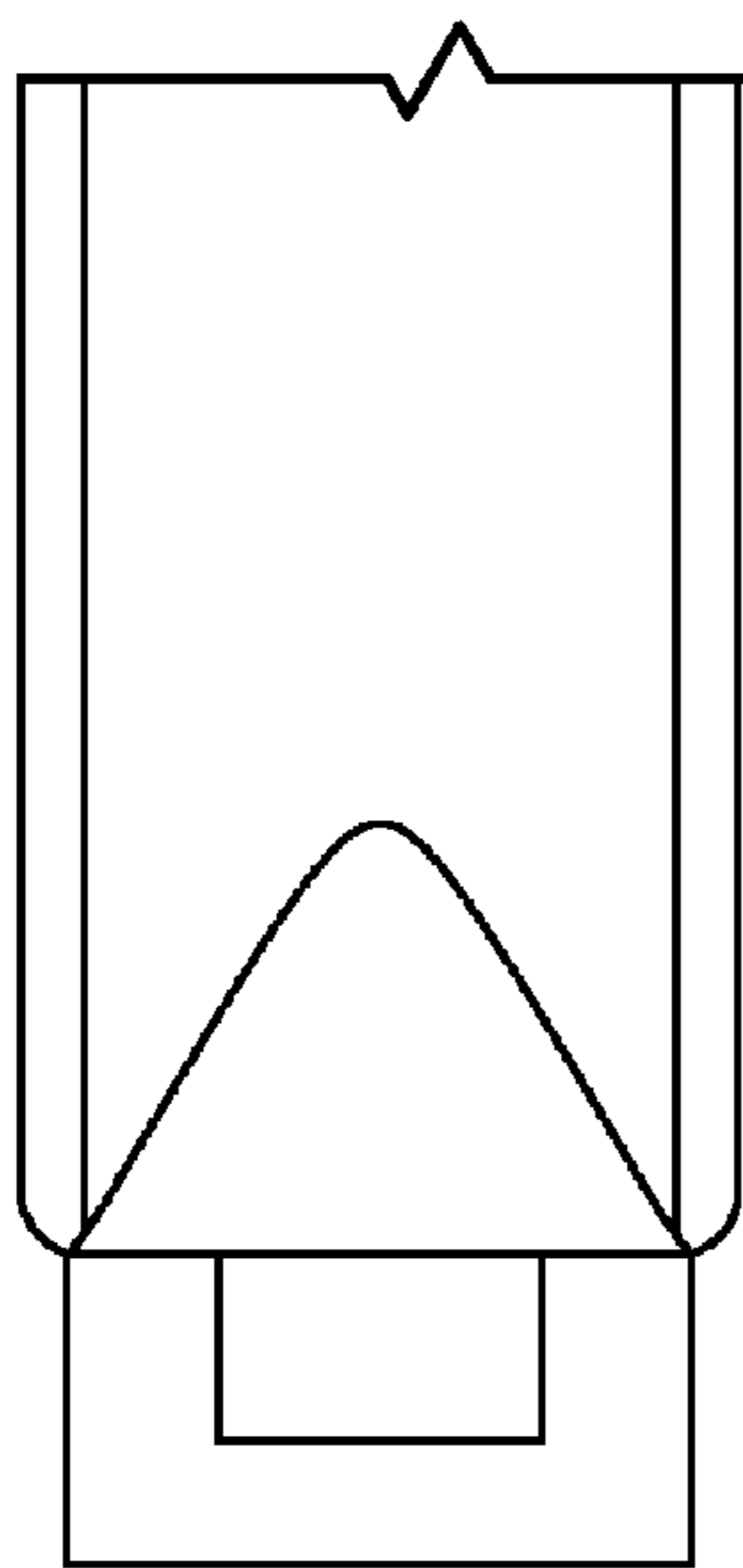

FIG. 7

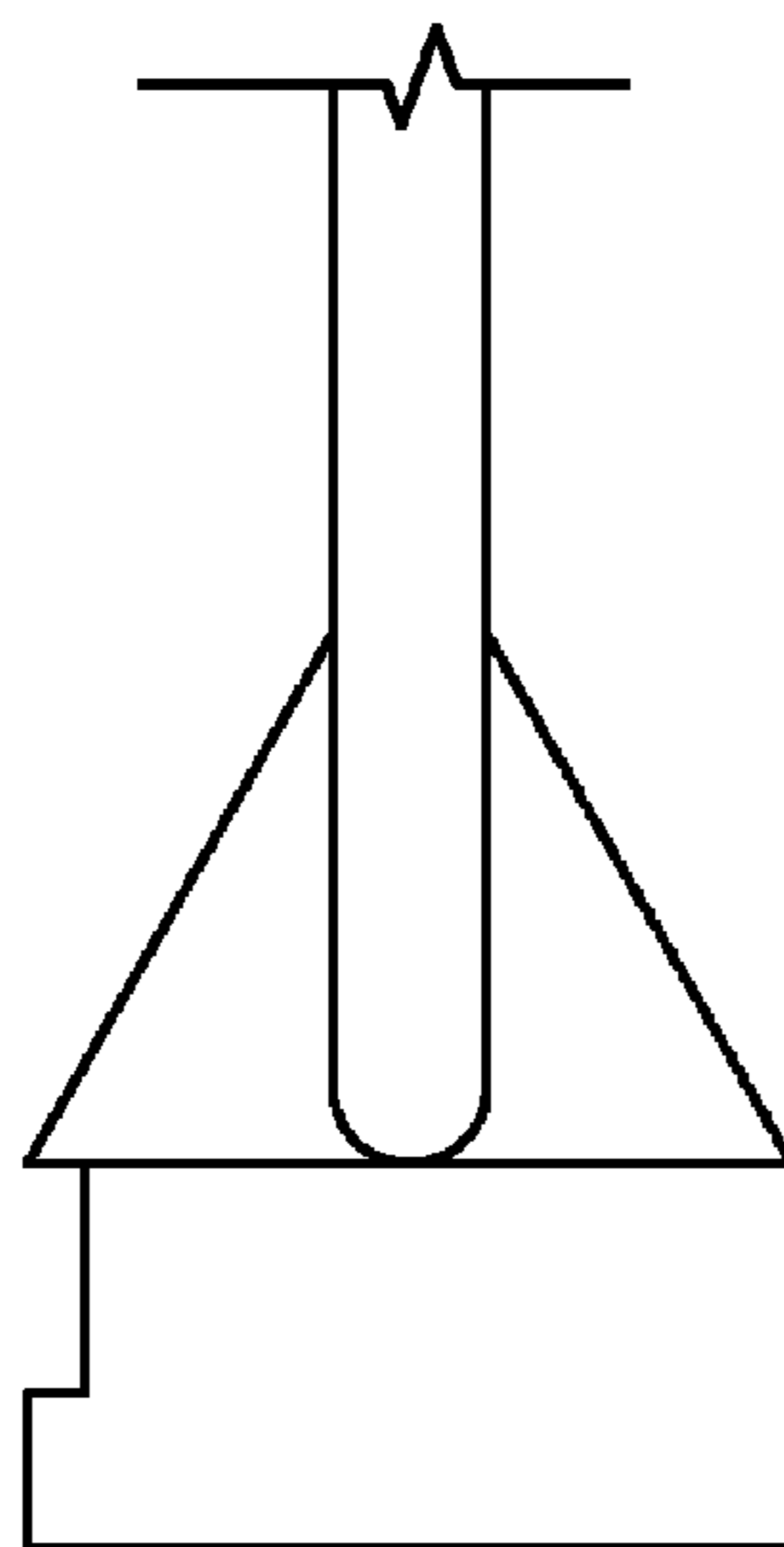

FIG. 8

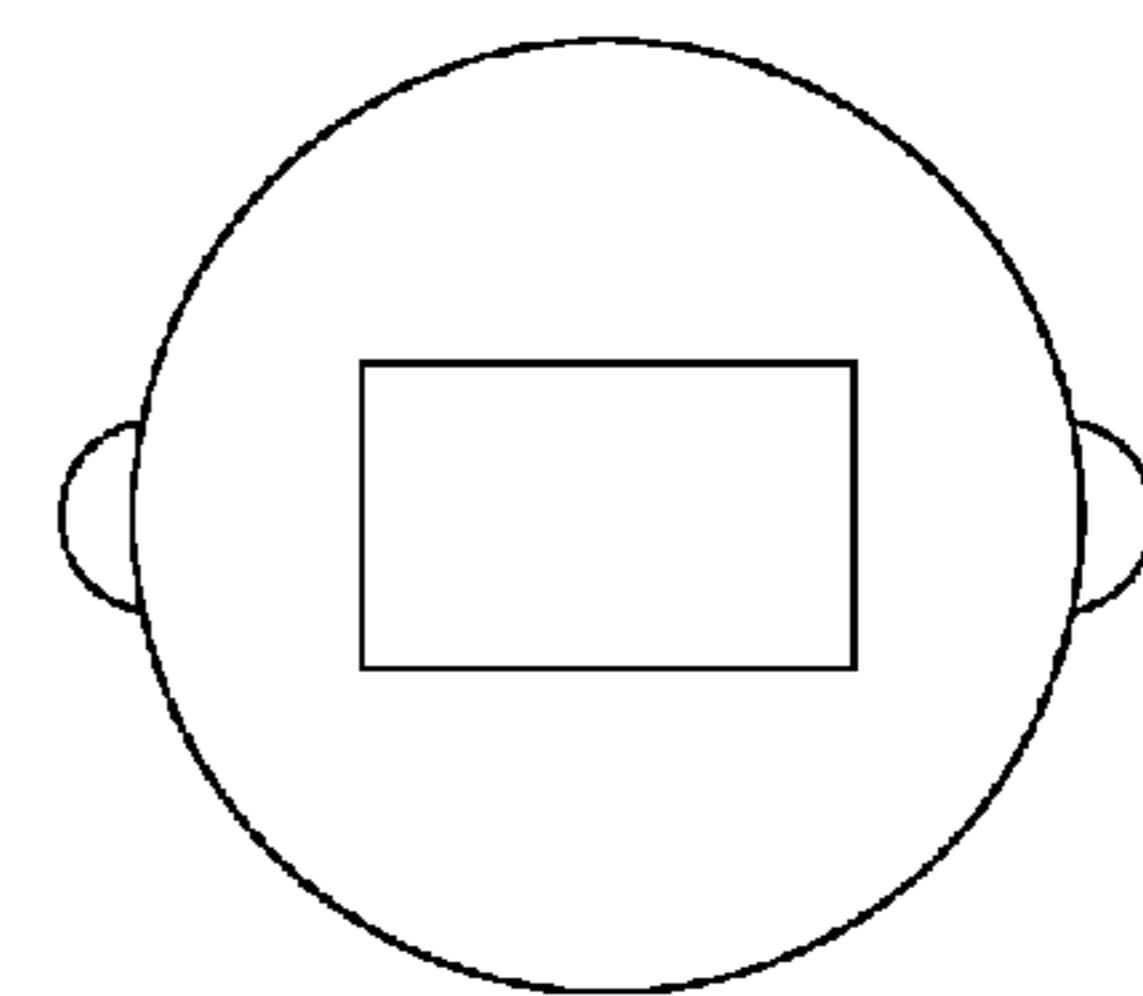

FIG. 9

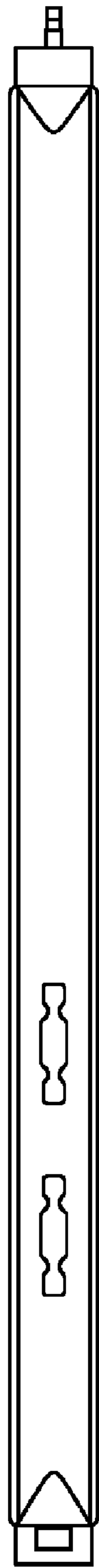

FIG. 10

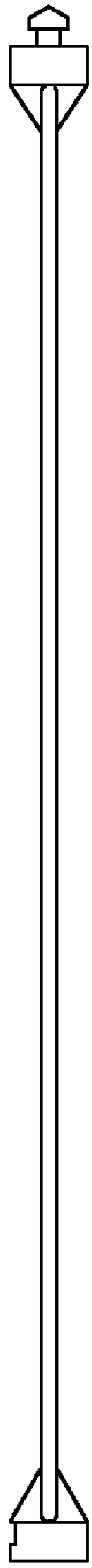

FIG. 11

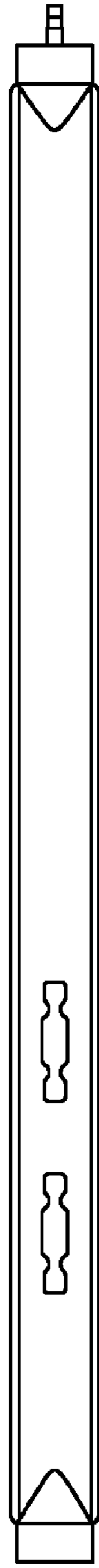

FIG. 12

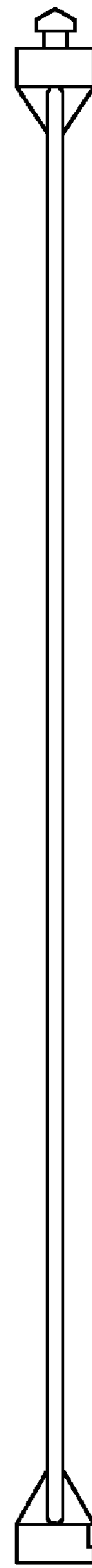

FIG. 13

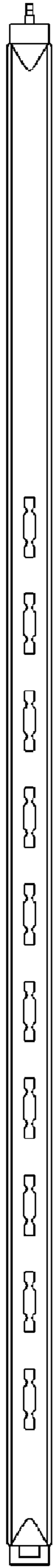

FIG. 14

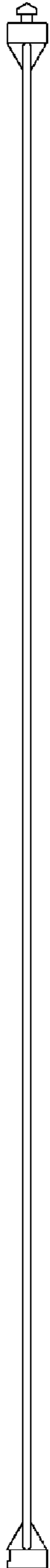

FIG. 15

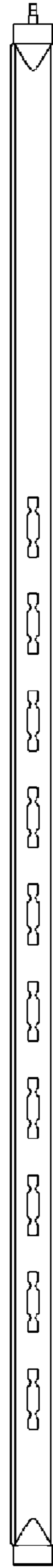

FIG. 16

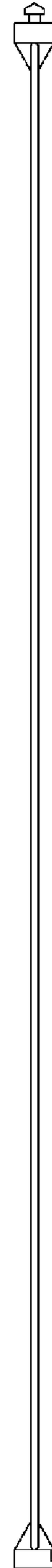

FIG. 17



FIG. 18

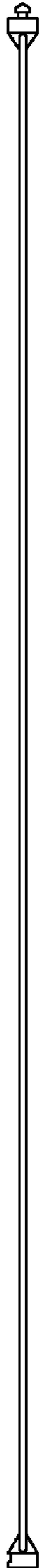

FIG. 19



FIG. 20

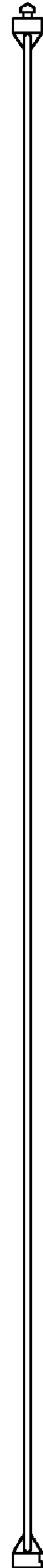

FIG. 21



FIG. 22

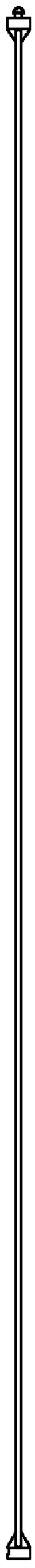

FIG. 23



FIG. 24

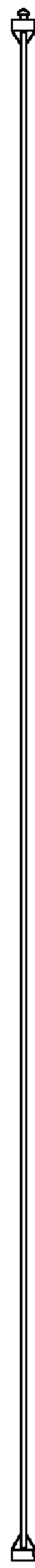

FIG. 25



FIG. 26



FIG. 27



FIG. 28



FIG. 29



FIG. 30



FIG. 31



FIG. 32



FIG. 33