



US00D631154S

(12) **United States Design Patent**
Hamilton, Jr.

(10) **Patent No.:** **US D631,154 S**
(45) **Date of Patent:** **** Jan. 18, 2011**

(54) **PROBE HANDLE TIP** 5,052,391 A 10/1991 Silberstone et al.
 5,058,605 A 10/1991 Slovak
 (75) Inventor: **William C. Hamilton, Jr.**, Queensbury, 5,098,843 A 3/1992 Calvin
 NY (US) 5,134,070 A 7/1992 Casnig
 5,137,517 A * 8/1992 Loney et al. 604/159
 (73) Assignee: **AngioDynamics, Inc.** D329,496 S * 9/1992 Wotton D24/140
 5,173,158 A 12/1992 Schmukler
 (**) Term: **14 Years** 5,193,537 A 3/1993 Freeman
 5,273,525 A 12/1993 Hofmann
 (21) Appl. No.: **29/338,393** 5,283,194 A 2/1994 Schmukler
 5,318,563 A 6/1994 Malis et al.
 (22) Filed: **Jun. 10, 2009** 5,328,451 A 7/1994 Davis et al.
 5,389,069 A 2/1995 Weaver
 5,403,311 A 4/1995 Abele et al.
 5,425,752 A 6/1995 Vu'Nguyen
 5,439,440 A 8/1995 Hofmann
 5,458,625 A 10/1995 Kendall
 5,533,999 A 7/1996 Hood et al.
 5,536,240 A 7/1996 Edwards et al.
 5,575,811 A 11/1996 Reid et al.
 5,626,146 A 5/1997 Barber et al.
 5,634,899 A 6/1997 Shapland et al.
 5,674,267 A 10/1997 Mir et al.
 5,702,359 A 12/1997 Hofmann
 5,720,921 A 2/1998 Meserol
 5,778,894 A 7/1998 Dorogi et al.
 5,782,882 A 7/1998 Lerman et al.
 5,800,378 A 9/1998 Edwards et al.
 5,810,762 A 9/1998 Hofmann
 5,836,897 A * 11/1998 Sakurai et al. 601/2
 5,836,905 A 11/1998 Lemelson et al.
 5,843,026 A 12/1998 Edwards et al.
 5,873,849 A 2/1999 Bernard
 5,919,142 A 7/1999 Boone et al.
 5,947,889 A 9/1999 Hehrlein
 5,983,131 A 11/1999 Weaver et al.
 5,991,697 A 11/1999 Nelson et al.
 5,999,847 A 12/1999 Elstrom
 6,009,347 A 12/1999 Hofmann
 6,010,613 A 1/2000 Walters et al.
 6,016,452 A 1/2000 Kasevich
 6,041,252 A 3/2000 Walker et al.
 6,055,453 A 4/2000 Hofmann et al.
 6,068,650 A 5/2000 Nanda et al.
 6,085,115 A 7/2000 Weaver et al.
 6,090,106 A 7/2000 Goble et al.
 6,102,885 A 8/2000 Bass
 6,106,521 A 8/2000 Blewett et al.
 6,109,270 A 8/2000 Mah et al.

Related U.S. Application Data

(63) Continuation of application No. 12/437,843, filed on May 8, 2009.

(51) **LOC (9) Cl.** **24-04**

(52) **U.S. Cl.** **D24/133**

(58) **Field of Classification Search** D24/133,
 D24/134, 135, 136, 137, 138, 139, 140, 141,
 D24/142, 143, 146, 150, 152, 171, 144, 145,
 D24/147, 148, 149, 151, 153, 154, 127, 128,
 D24/129, 130, 106-108, 112, 111, 200;
 D23/40, 47, 57, 60, 67, 68, 69, 80, 82, 83,
 D23/84, 93, 94, 97, 107; D8/72, 73, 74;
 600/184, 201-203, 210-218, 220-223, 224,
 600/225-227; 606/7, 86 A, 86 B, 119

See application file for complete search history.

(56) **References Cited**

U.S. PATENT DOCUMENTS

1,653,819 A 12/1927 Northcott et al.
 D191,088 S * 8/1961 Anderson D24/112
 3,730,238 A * 5/1973 Butler 81/29
 4,016,886 A 4/1977 Doss
 4,226,246 A 10/1980 Fragnet
 4,262,672 A 4/1981 Kief
 4,407,943 A 10/1983 Cole et al.
 D294,519 S * 3/1988 Hardy, Jr. D24/144
 4,810,963 A 3/1989 Blake-Coleman et al.
 4,907,601 A 3/1990 Frick
 4,946,793 A 8/1990 Marshall, III
 5,019,034 A 5/1991 Weaver et al.

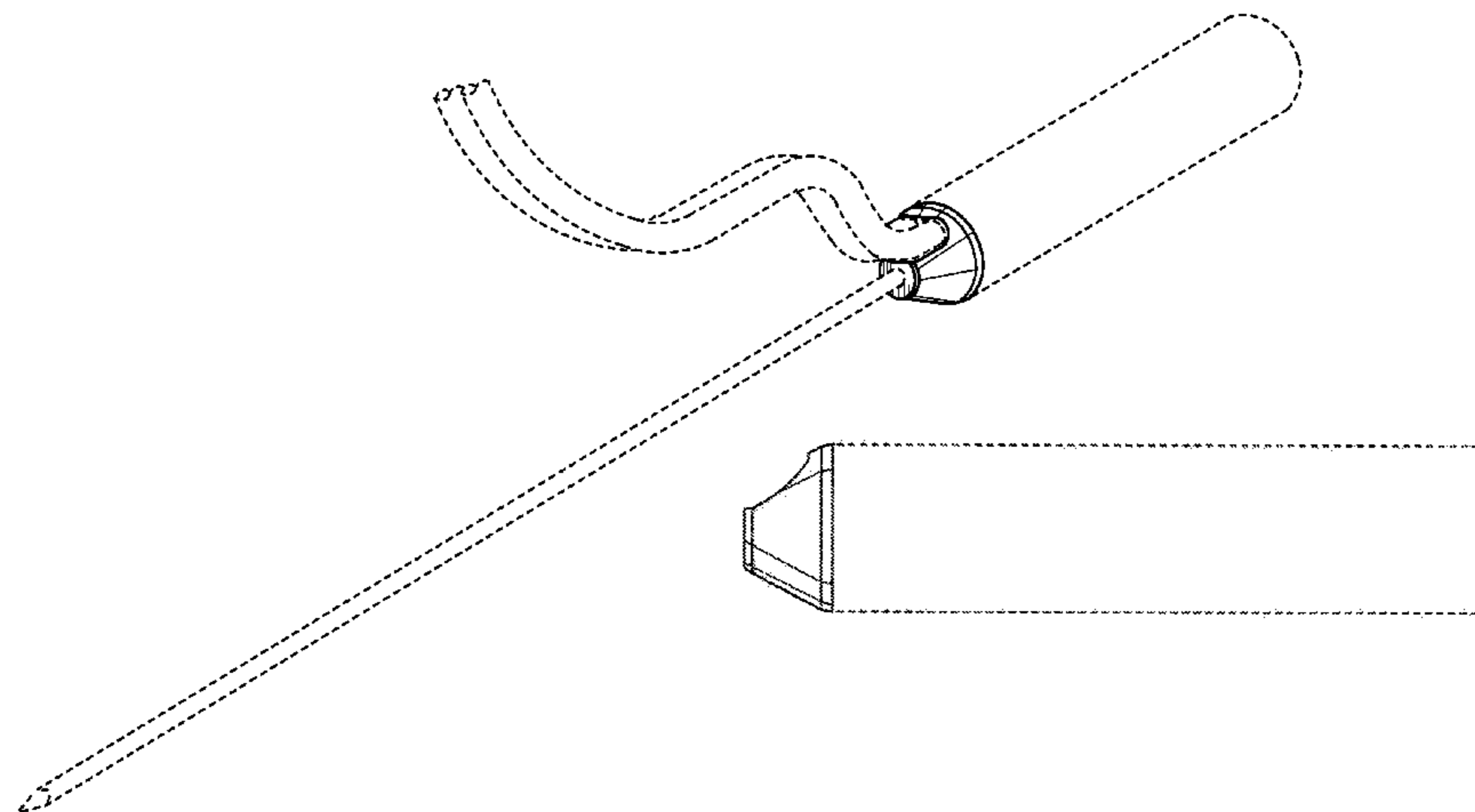

US D631,154 S

Page 2

6,122,599	A	9/2000	Mehta	2004/0267189	A1	12/2004	Mavor et al.
6,132,419	A	10/2000	Hofmann	2005/0043726	A1	2/2005	McHale et al.
6,159,163	A	12/2000	Strauss et al.	2005/0049541	A1	3/2005	Behar et al.
6,208,893	B1	3/2001	Hofmann	2005/0165393	A1	7/2005	Eppstein
6,210,402	B1	4/2001	Olsen et al.	2005/0171523	A1	8/2005	Rubinsky et al.
6,212,433	B1	4/2001	Behl	2005/0171574	A1	8/2005	Rubinsky et al.
6,216,034	B1	4/2001	Hofmann	2005/0182462	A1	8/2005	Chornenky et al.
6,219,577	B1	4/2001	Brown et al.	2005/0261672	A1	11/2005	Deem et al.
D443,360	S *	6/2001	Haberland D24/146	2005/0288730	A1	12/2005	Deem et al.
6,241,702	B1	6/2001	Lundquist et al.	2006/0015147	A1	1/2006	Persson et al.
6,261,831	B1	7/2001	Agee	2006/0025760	A1	2/2006	Podhajsky
6,278,895	B1	8/2001	Bernard	2006/0079883	A1	4/2006	Elmouelhi et al.
6,300,108	B1	10/2001	Rubinsky	2006/0121610	A1	6/2006	Rubinsky et al.
6,326,177	B1	12/2001	Schoenbach et al.	2006/0212078	A1	9/2006	Demarais et al.
6,347,247	B1	2/2002	Dev et al.	2006/0217703	A1	9/2006	Chornenky et al.
6,349,233	B1	2/2002	Adams	2006/0264752	A1	11/2006	Rubinsky et al.
6,351,674	B2	2/2002	Silverstone	2007/0043345	A1	2/2007	Davalos et al.
6,387,671	B1	5/2002	Rubinsky et al.	2007/0118069	A1	5/2007	Persson et al.
6,403,348	B1	6/2002	Rubinsky et al.	2008/0052786	A1	2/2008	Lin et al.
6,470,211	B1	10/2002	Ideker et al.	2009/0281477	A1	11/2009	Mikus et al.
6,482,619	B1	11/2002	Rubinsky et al.	2009/0326570	A1 *	12/2009	Brown 606/186
6,493,592	B1	12/2002	Leonard et al.				
6,500,173	B2	12/2002	Underwood et al.				
6,526,320	B2	2/2003	Mitchell				
6,562,604	B2	5/2003	Rubinsky et al.				
6,607,529	B1	8/2003	Jones et al.				
6,611,706	B2	8/2003	Avrahami et al.				
6,613,211	B1	9/2003	McCormick et al.				
6,627,421	B1	9/2003	Unger et al.				
6,653,091	B1	11/2003	Dunn et al.				
6,669,691	B1	12/2003	Taimisto				
6,692,493	B2	2/2004	McGovern et al.				
6,697,669	B2	2/2004	Dev et al.				
6,697,670	B2	2/2004	Chornenky et al.				
6,702,808	B1	3/2004	Kreindel				
6,795,728	B2	9/2004	Chornenky et al.				
6,801,804	B2	10/2004	Miller et al.				
6,865,416	B2	3/2005	Dev et al.				
6,892,099	B2	5/2005	Jaafar et al.				
6,912,417	B1	6/2005	Bernard et al.				
6,927,049	B2	8/2005	Rubinsky et al.				
6,962,587	B2	11/2005	Johnson et al.				
6,972,014	B2	12/2005	Eum et al.				
6,994,706	B2	2/2006	Chornenky et al.				
7,053,063	B2	5/2006	Rubinsky et al.				
7,063,698	B2	6/2006	Whayne et al.				
7,097,612	B2 *	8/2006	Bertolero et al. 600/37				
7,130,697	B2	10/2006	Chornenky et al.				
7,211,083	B2	5/2007	Chornenky et al.				
D549,332	S *	8/2007	Matsumoto et al. D24/138				
7,267,676	B2	9/2007	Chornenky et al.				
7,341,558	B2 *	3/2008	de la Torre et al. 600/204				
D575,399	S *	8/2008	Matsumoto et al. D24/138				
D575,402	S *	8/2008	Sandor D24/146				
2001/0044596	A1	11/2001	Jaafar				
2002/0010491	A1	1/2002	Schoenbach				
2002/0055731	A1	5/2002	Atala et al.				
2002/0077676	A1	6/2002	Schroepel et al.				
2002/0099323	A1	7/2002	Dev et al.				
2002/0138117	A1	9/2002	Son				
2002/0193831	A1	12/2002	Smith, III				
2003/0009110	A1	1/2003	Tu et al.				
2003/0060856	A1	3/2003	Chornenky et al.				
2003/0088189	A1	5/2003	Tu et al.				
2003/0130711	A1	7/2003	Pearson et al.				
2003/0170898	A1	9/2003	Gundersen et al.				
2003/0208200	A1	11/2003	Palanker et al.				
2003/0225360	A1	12/2003	Eppstein et al.				
2004/0019371	A1	1/2004	Jaafar et al.				
2004/0059389	A1	3/2004	Chornenky et al.				
2004/0146877	A1	7/2004	Diss et al.				
2004/0153057	A1	8/2004	Davison				
2004/0243107	A1	12/2004	Mackoviak				

FOREIGN PATENT DOCUMENTS

DE	863111	1/1953
DE	4000893	7/1991
EP	0378132	7/1990
EP	0935482	5/2005
WO	9639531	4/2000
WO	0020554	2/2001
WO	0107583	2/2001
WO	0107584	2/2001
WO	0107585	2/2001
WO	0181533	11/2001
WO	2004037341	5/2004

OTHER PUBLICATIONS

Amasha, et al., Quantitative Assessment of Impedance Tomography for Temperature Measurements in Microwave Hyperthermia, *Clin. Phys. Physiol. Meas.*, 1998, Suppl. A, 49-53.

Andreason, Electroporation as a Technique for the Transfer of Macromolecules into Mammalian Cell Lines, *J. Tiss. Cult. Meth.*, 15:56-62, 1993.

Baker, et al., Calcium-Dependent Exocytosis in Bovine Adrenal Medullary Cells with Leaky Plasma Membranes, *Nature*, vol. 276, pp. 620-622, 1978.

Barber, Electrical Impedance Tomography Applied Potential Tomography, *Advances in Biomedical Engineering*, Beneken and Thevenin, eds., IOS Press, 1993.

Beebe, S.J., et al., Nanosecond pulsed electric field (nsPEF) effects on cells and tissues: apoptosis induction and tumor growth inhibition. PPS-2001 Pulsed Power Plasma Science 2001, 28th IEEE International Conference on Plasma Science and 13th IEEE International Pulsed Power Conference, Digest of Technical Papers (Cat. No. 01CH37251). IEEE, Part vol. 1, 2001, pp. 211-215, vol. I, Piscataway, NJ, USA.

Blad, et al., Impedance Spectra of Tumour Tissue in Comparison with Normal Tissue; a Possible Clinical Application for Electrical Impedance Tomography, *Physiol. Meas.* 17 (1996) A105-A115.

Brown, S.G., Phototherapy of tumors. *World J. Surgery*, 1983. 7: p. 700-9.

BPH Management Strategies: Improving Patient Satisfaction, *Urology Times*, May 2001, vol. 29, Supplement 1.

Brown, et al., Blood Flow Imaging Using Electrical Impedance Tomography, *Clin. Phys. Physiol. Meas.*, 1992, vol. 13, Suppl. A, 175-179.

Chandrasekar, et al., Transurethral Needle Ablation of the Prostate (TUNA)—a Propsective Study, Six Year Follow Up, (Abstract), Presented at 2001 National Meeting, Anaheim, CA, Jun. 5, 2001.

Coates, C.W., et al., "The Electrical Discharge of the Electric Eel, *Electrophorous Electricus*," *Zoologica*, 1937, 22(1), pp. 1-32.

- Cook, et al., ACT3: A High-Speed, High-Precision Electrical Impedance Tomograph, *IEEE Transactions on Biomedical Engineering*, vol. 41, No. 8, Aug. 1994.
- Cowley, Good News for Boomers, *Newsweek*, Dec. 30, 1996/Jan. 6, 1997.
- Cox, et al., Surgical Treatment of Atrial Fibrillation: A Review, *Europace* (2004) 5, S20-S-29.
- Crowley, Electrical Breakdown of Biomolecular Lipid Membranes as an Electromechanical Instability, *Biophysical Journal*, vol. 13, pp. 711-724, 1973.
- Davalos, et al., Tissue Ablation with Irreversible Electroporation, *Annals of Biomedical Engineering*, vol. 33, No. 2, Feb. 2005.
- Davalos, et al., Theoretical Analysis of the Thermal Effects During In Vivo Tissue Electroporation, *Bioelectrochemistry*, vol. 61, pp. 99-107, 2003.
- Davalos, et al., A Feasibility Study for Electrical Impedance Tomography as a Means to Monitor Tissue Electroporation for Molecular Medicine, *IEEE Transactions on Biomedical Engineering*, vol. 49, No. 4, Apr. 2002.
- Davalos, Real-Time Imaging for Molecular Medicine through Electrical Impedance Tomography of Electroporation, Dissertation for Ph.D. in Engineering-Mechanical Engineering, Graduate Division of University of California, Berkeley, 2002.
- Dean, Nonviral Gene Transfer to Skeletal, Smooth, and Cardiac Muscle in Living Animals, *Am J. Physiol Cell Physiol* 289: 233-245, 2005.
- Dev, et al., Sustained Local Delivery of Heparin to the Rabbit Arterial Wall with an Electroporation Catheter, *Catheterization and Cardiovascular Diagnosis*, Nov. 1998, vol. 45, No. 3, pp. 337-343.
- Dev, et al., Medical Applications of Electroporation, *IEEE Transactions of Plasma Science*, vol. 28, No. 1, pp. 206-223, Feb. 2000.
- Duraiswami, et al., Boundary Element Techniques for Efficient 2-D and 3-D Electrical Impedance Tomography, *Chemical Engineering Science*, vol. 52, No. 13, pp. 2185-2196, 1997.
- Duraiswami, et al., Efficient 2D and 3D Electrical Impedance Tomography Using Dual Reciprocity Boundary Element Techniques, *Engineering Analysis with Boundary Elements* 22, (1998) 13-31.
- Duraiswami, et al., Solution of Electrical Impedance Tomography Equations Using Boundary Element Methods, *Boundary Element Technology* XII, 1997, pp. 226-237.
- Edd, J., et al., In-Vivo Results of a New Focal Tissue Ablation Technique: Irreversible Electroporation, *IEEE Trans. Biomed. Eng.* 53 (2006) p. 1409-1415.
- Erez, et al., Controlled Destruction and Temperature Distributions in Biological Tissues Subjected to Monoactive Electrocoagulation, *Transactions of the ASME: Journal of Mechanical Design*, vol. 102, Feb. 1980.
- Foster, R.S., et al., High-intensity focused ultrasound in the treatment of prostatic disease. *Eur. Urol.*, 1993. 23: 44-7).
- Fox, et al., Sampling Conductivity Images via MCMC, Mathematics Department, Auckland University, New Zealand, May 1997.
- Gauger, et al., A Study of Dielectric Membrane Breakdown in the Fucus Egg, *J. Membrane Biol.*, vol. 48, No. 3, pp. 249-264, 1979.
- Gehl, et al., In Vivo Electroporation of Skeletal Muscle: Threshold, Efficacy and Relation to Electric Field Distribution, *Biochimica et Biophysica Acta* 1428, 1999, pp. 233-240.
- Gençer, et al., Electrical Impedance Tomography: Induced-Current Imaging Achieved with a Multiple Coil System, *IEEE Transactions on Biomedical Engineering*, vol. 43, No. 2, Feb. 1996.
- Gilbert, et al., Novel Electrode Designs for Electrochemotherapy, *Biochimica et Biophysica Acta* 1334, 1997, pp. 9-14.
- Gilbert, et al., The Use of Ultrasound Imaging for Monitoring Cryosurgery, Proceedings 6th Annual Conference, IEEE Engineering in Medicine and Biology, 107-111, 1984.
- Glidewell, et al., The Use of Magnetic Resonance Imaging Data and the Inclusion of Anisotropic Regions in Electrical Impedance Tomography, *Biomed. Sci. Instrum.* 1993; 29: 251-7.
- Gothelf, et al., Electrochemotherapy: Results of Cancer Treatment Using Enhanced Delivery of Bleomycin by Electroporation, *Cancer Treatment Reviews* 2003; 29: 371-387.
- Griffiths, et al., A Dual-Frequency Electrical Impedance Tomography System, *Phys. Med. Biol.*, 1989, vol. 34, No. 10, pp. 1465-1476.
- Griffiths, The Importance of Phase Measurement in Electrical Impedance Tomography, *Phys. Med. Biol.*, 1987, vol. 32, No. 11, pp. 1435-1444.
- Griffiths, Tissue Spectroscopy with Electrical Impedance Tomography: Computer Simulations, *IEEE Transactions on Biomedical Engineering*, vol. 42, No. 9, Sep. 1995.
- Gumerov, et al., The Dipole Approximation Method and Its Coupling with the Regular Boundary Element Method for Efficient Electrical Impedance Tomography, *Boundary Element Technology* XIII, 1999.
- Hapala, Breaking the Barrier: Methods for Reversible Permeabilization of Cellular Membranes, *Critical Reviews in Biotechnology*, 17(2): 105-122, 1997.
- Heller, et al., Clinical Applications of Electrochemotherapy, *Advanced Drug Delivery Reviews*, vol. 35, pp. 119-129, 1999.
- Ho, et al., Electroporation of Cell Membranes: A Review, *Critical Reviews in Biotechnology*, 16(4): 349-362, 1996.
- Holder, et al., Assessment and Calibration of a Low-Frequency System for Electrical Impedance Tomography (EIT), Optimized for Use in Imaging Brain Function in Ambulant Human Subjects, *Annals of the New York Academy of Science*, vol. 873, Issue 1, Electrical BI, pp. 512-519, 1999.
- Huang, et al., Micro-Electroporation: Improving the Efficiency and Understanding of Electrical Permeabilization of Cells, *Biomedical Microdevices*, vol. 2, pp. 145-150, 1999.
- Hughes, et al., An Analysis of Studies Comparing Electrical Impedance Tomography with X-Ray Videofluoroscopy in the Assessment of Swallowing, *Physiol. Meas.* 15, 1994, pp. A199-A209.
- Issa, et al., The TUNA Procedure for BPH: Review of the Technology: The TUNA Procedure for BPH: Basic Procedure and Clinical Results, Reprinted from *Infections in Urology*, Jul./Aug. 1998 and Sep./Oct. 1998.
- Ivanuša, et al., MRI Macromolecular Contrast Agents as Indicators of Changed Tumor Blood Flow, *Radiol. Oncol.* 2001; 35(2): 139-47.
- Jaroszeski, et al., In Vivo Gene Delivery by Electroporation, *Advanced Drug Delivery Review*, vol. 35, pp. 131-137, 1999.
- Kinosita, et al., Hemolysis of Human Erythrocytes by a Transient Electric Field, *Proc. Natl. Acad. Sci. USA*, vol. 74, No. 5, pp. 1923-1927, 1977.
- Liu, et al., Measurement of Pharyngeal Transit Time by Electrical Impedance Tomography, *Clin. Phys. Physiol. Meas.*, 1992, vol. 13, Suppl. A, pp. 197-200.
- Lundqvist, et al., Altering the Biochemical State of Individual Cultured Cells and Organelles with Ultramicroelectrodes, *Proc. Natl. Acad. Sci. USA*, vol. 95, pp. 10356-10360, Sep. 1998.
- Lurquin, Gene Transfer by Electroporation, *Molecular Biotechnology*, vol. 7, 1997.
- Lynn, et al., A New Method for the Generation and Use of Focused Ultrasound in Experimental Biology, *The Journal of General Physiology*, vol. 26, 179-193, 1942.
- Miklavčič, et al., A Validated Model of an in Vivo Electric Field Distribution in Tissues for Electrochemotherapy and for DNA Electrotransfer for Gene Therapy, *Biochimica et Biophysica Acta* 1523 (2000), pp. 73-83.
- Miklavčič, et al., The Importance of Electric Field Distribution for Effective in Vivo Electroporation of Tissues, *Biophysical Journal*, vol. 74, May 1998, pp. 2152-2158.
- Miller, L., et al., Cancer cells ablation with irreversible electroporation, *Technology in Cancer Research and Treatment* 4 (2005) 699-706.
- Mir, Therapeutic Perspectives of In Vivo Cell Electropermeabilization, *Bioelectrochemistry*, vol. 53, pp. 1-10, 2000.
- Mir, L.M., et al., Electric Pulse-Mediated Gene Delivery to Various Animal Tissues, in *Advances in Genetics*, Academic Press, 2005, p. 83-114.
- Mir, L.M. and Orlowski, S., The basis of electrochemotherapy, in *Electrochemotherapy, electrogenotherapy, and transdermal drug delivery: electrically mediated delivery of molecules to cells*, M.J. Jaroszeski, R. Heller, R. Gilbert, Editors, 2000, Humana Press, p. 99-118.

Mir, et al., Effective Treatment of Cutaneous and Subcutaneous Malignant Tumours by Electrochemotherapy, *British Journal of Cancer*, vol. 77, No. 12, pp. 2336-2342, 1998.

Mir, et al., Electrochemotherapy Potentiation of Antitumour Effect of Bleomycin by Local Electric Pulses, *European Journal of Cancer*, vol. 27, No. 1, pp. 68-72, 1991.

Mir, et al., Electrochemotherapy, a Novel Antitumor Treatment: First Clinical Trial, *C.R. Acad. Sci. Paris*, Ser. III, vol. 313, pp. 613-618, 1991.

Narayan, et al., Establishment and Characterization of a Human Primary Prostatic Adenocarcinoma Cell Line (ND-1), *The Journal of Urology*, vol. 148, 1600-1604, Nov. 1992.

Naslund, Michael J., Transurethral Needle Ablation of the Prostate, *Urology*, vol. 50, No. 2, Aug. 1997.

Naslund, Cost-Effectiveness of Minimally Invasive Treatments and Transurethral Resection (TURP) in Benign Prostatic Hyperplasia (BPH), (Abstract), Presented at 2001 AUA National Meeting, Anaheim, CA, Jun. 5, 2001.

Neumann, et al., Gene Transfer into Mouse Lyoma Cells by Electroporation in High Electric Fields, *J. Embo.*, vol. 1, No. 7, pp. 841-845, 1982.

Neumann, et al., Permeability Changes Induced by Electric Impulses in Vesicular Membranes, *J. Membrane Biol.*, vol. 10, pp. 279-290, 1972.

Okino, et al., Effects of High-Voltage Electrical Impulse and an Anticancer Drug on In Vivo Growing Tumors, *Japanese Journal of Cancer Research*, vol. 78, pp. 1319-1321, 1987.

Onik, et al., Sonographic Monitoring of Hepatic Cryosurgery in an Experimental Animal Model, *AJR American J. of Roentgenology*, vol. 144, pp. 1043-1047, May 1985.

Onik, et al., Ultrasonic Characteristics of Frozen Liver, *Cryobiology*, vol. 21, pp. 321-328, 1984.

Organ, L.W., Electrophysiological principles of radiofrequency lesion making, *Apply. Neurophysiol.*, 1976. 39: p. 69-76.

Piñero, et al., Apoptotic and Necrotic Cell Death Are Both Induced by Electroporation in HL60 Human Promyeloid Leukaemia Cells, *Apoptosis*, vol. 2, No. 3, 330-336, Aug. 1997.

Precision Office TUNA System, When Patient Satisfaction is Your Goal.

Rols, M.P., et al., Highly Efficient Transfection of Mammalian Cells by Electric Field Pulses: Application to Large Volumes Of Cell Culture by Using a Flow System, *Eur. J. Biochem.* 1992, 206, pp. 115-121.

Rubinsky, B., ed, Cryosurgery. *Annu Rev. Biomed. Eng.* vol. 2 2000. 157-187.

Schmukler, Impedance Spectroscopy of Biological Cells, downloaded from IEEE Xplore website.

Sersa, et al., Reduced Blood Flow and Oxygenation in SA-1 Tumours after Electrochemotherapy with Cisplatin, *British Journal of Cancer*, 87, 1047-1054, 2002.

Sersa, et al., Tumour Blood Flow Modifying Effects of Electrochemotherapy: a Potential Vascular Targeted Mechanism, *Radiol. Oncol.*, 37(1): 43-8, 2003.

Sharma, et al., Poloxamer 188 Decreases Susceptibility of Artificial Lipid Membranes to Electroporation, *Biophysical Journal*, vol. 71, No. 6, pp. 3229-3241, Dec. 1996.

Shiina, S., et al, Percutaneous ethanol injection therapy for hepatocellular carcinoma: results in 146 patients. *AJR*, 1993, 160: p. 1023-8.

Thompson, et al., To determine whether the temperature of 2% lignocaine gel affects the initial discomfort which may be associated with its instillation into the male urethra, *BJU International* (1999), 84, 1035-1037.

TUNA—Suggested Local Anesthesia Guidelines.

Vidamed, Inc., Transurethral Needle Ablation (TUNA): Highlights from Worldwide Clinical Studies, Vidamed's Office TUNA System.

Weaver, Electroporation: A General Phenomenon for Manipulating Cells and Tissues, *Journal of Cellular Biochemistry*, 51: 426-435, 1993.

Weaver, et al., Theory of Electroporation: A Review, *Bioelectrochemistry and Bioenergetics*, vol. 41, pp. 136-160, 1996.

Zimmermann, et al., Dielectric Breakdown of Cell Membranes, *Biophysical Journal*, vol. 14, No. 11, pp. 881-899, 1974.

Zlotta, et al., Possible Mechanisms of Action of Transurethral Needle Ablation of the Prostate on Benign Prostatic Hyperplasia Symptoms: a Neurohistochemical Study, Reprinted from *Journal of Urology*, vol. 157, No. 3, Mar. 1997, pp. 894-899.

Zlotta, et al., Long-Term Evaluation of Transurethral Needle Ablation of the Prostate (TUNA) for Treatment of Benign Prostatic Hyperplasia (BPH): Clinical Outcome After 5 Years. (Abstract) Presented at 2001 AUA National Meeting, Anaheim, CA—Jun. 5, 2001.

* cited by examiner

Primary Examiner—Bridget L Eland

(74) Attorney, Agent, or Firm—Tara L. Custer

(57)

CLAIM

The ornamental design for a probe handle tip, substantially as shown and described.

DESCRIPTION

FIG. 1 is an overall perspective view of a probe handle tip as seen from the front, top and right side.

FIG. 2 is an enlarged perspective view of the probe handle tip of FIG. 1.

FIG. 3 is an enlarged right side elevation view of the probe handle tip of FIG. 1.

FIG. 4 is an enlarged front elevation view of the probe handle tip of FIG. 1.

FIG. 5 is an enlarged rear elevation view of the probe handle tip of FIG. 1.

FIG. 6 is an enlarged left side elevation view of the probe handle tip of FIG. 1.

FIG. 7 is an enlarged top plan view of the probe handle tip of FIG. 1.

FIG. 8 is an enlarged bottom plan view of the probe handle tip of FIG. 1.

FIG. 9 is an overall perspective view of a second embodiment of a probe handle tip as seen from the front, top and right side.

FIG. 10 is an enlarged perspective view of the probe handle tip of FIG. 9.

FIG. 11 is an enlarged right side elevation view of the probe handle tip of FIG. 9.

FIG. 12 is an enlarged front elevation view of the probe handle tip of FIG. 9.

FIG. 13 is an enlarged rear elevation view of the probe handle tip of FIG. 9.

FIG. 14 is enlarged left side elevation view of the probe handle tip of FIG. 9.

FIG. 15 is an enlarged top plan view of the probe handle tip of FIG. 9; and,

FIG. 16 is an enlarged bottom plan view of the probe handle tip of FIG. 9.

The outer most broken lines immediately adjacent the shaded areas and the claimed areas represent the bounds of the claimed design while all other broken lines are directed to environment, and are for illustrative purposes only; the broken lines form no part of the claimed design.

FIG. 1

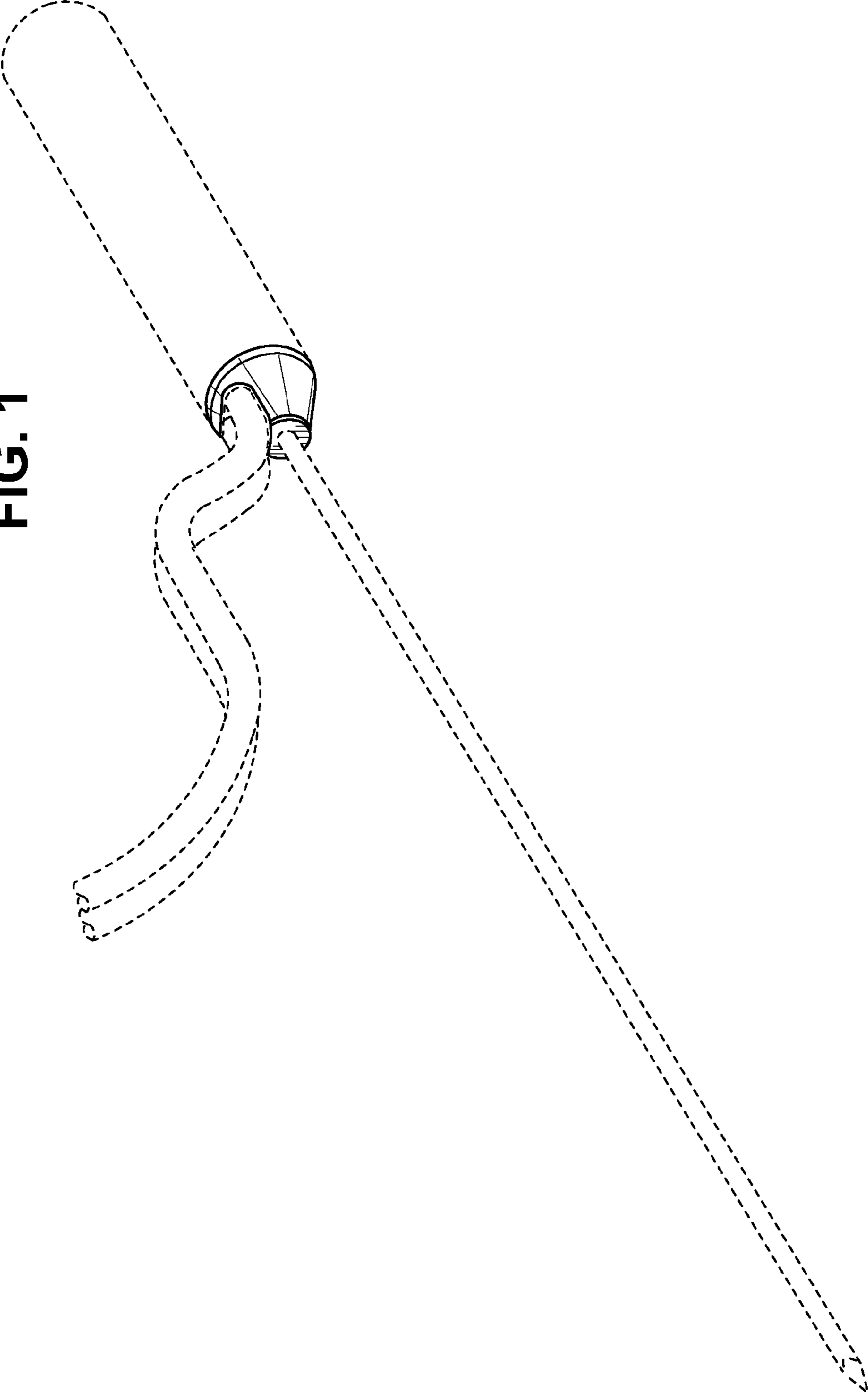

FIG. 2

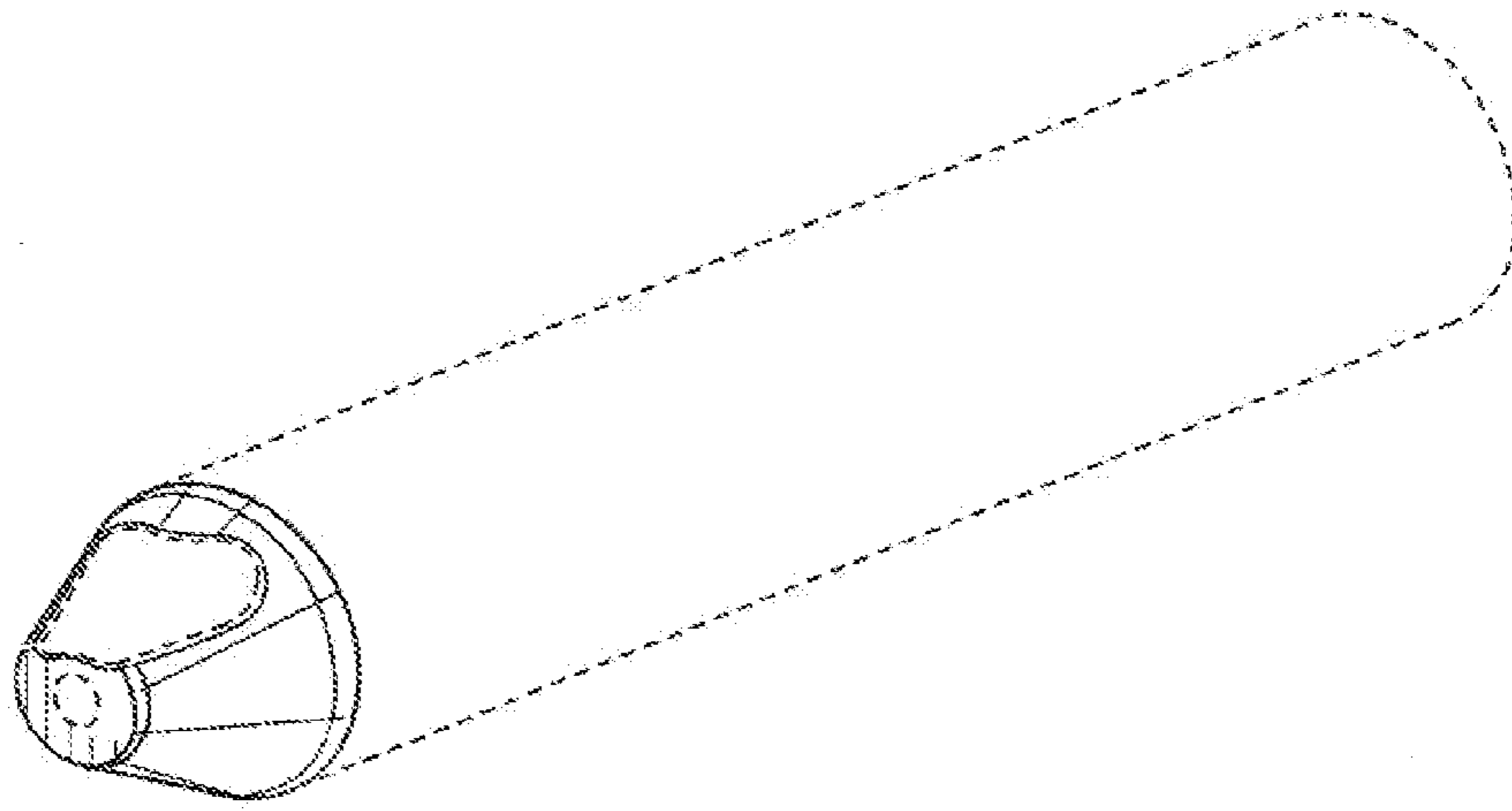

FIG. 3



FIG. 4

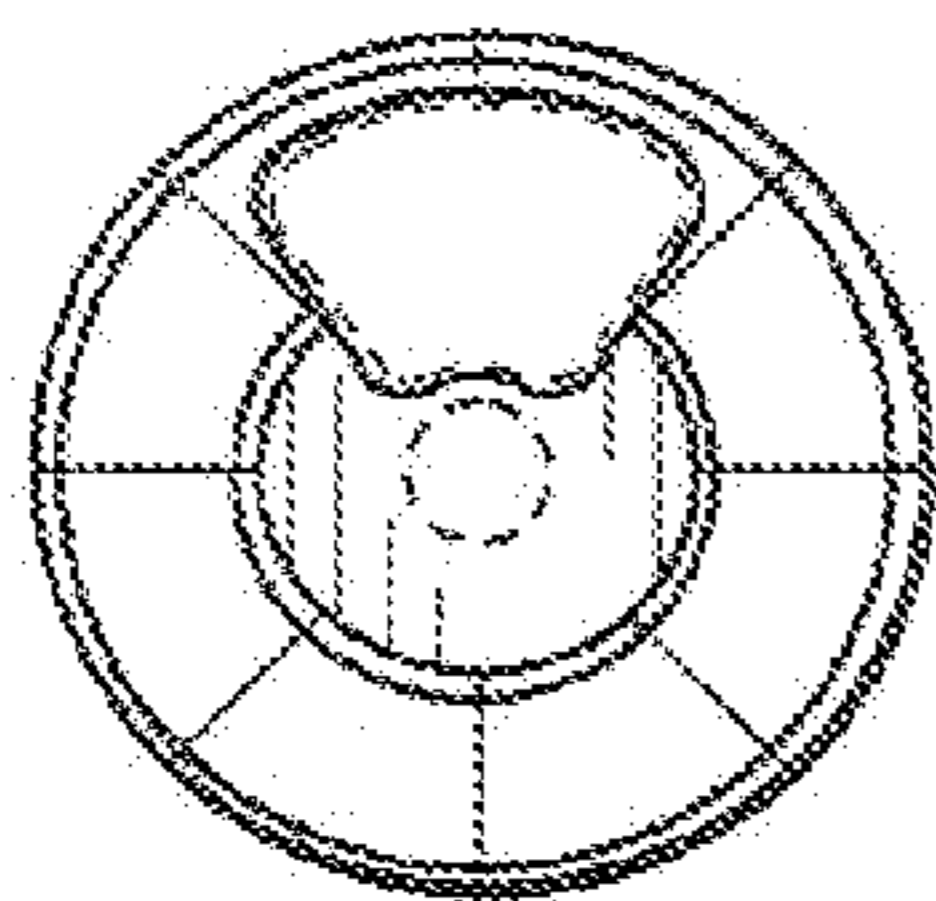

FIG. 5

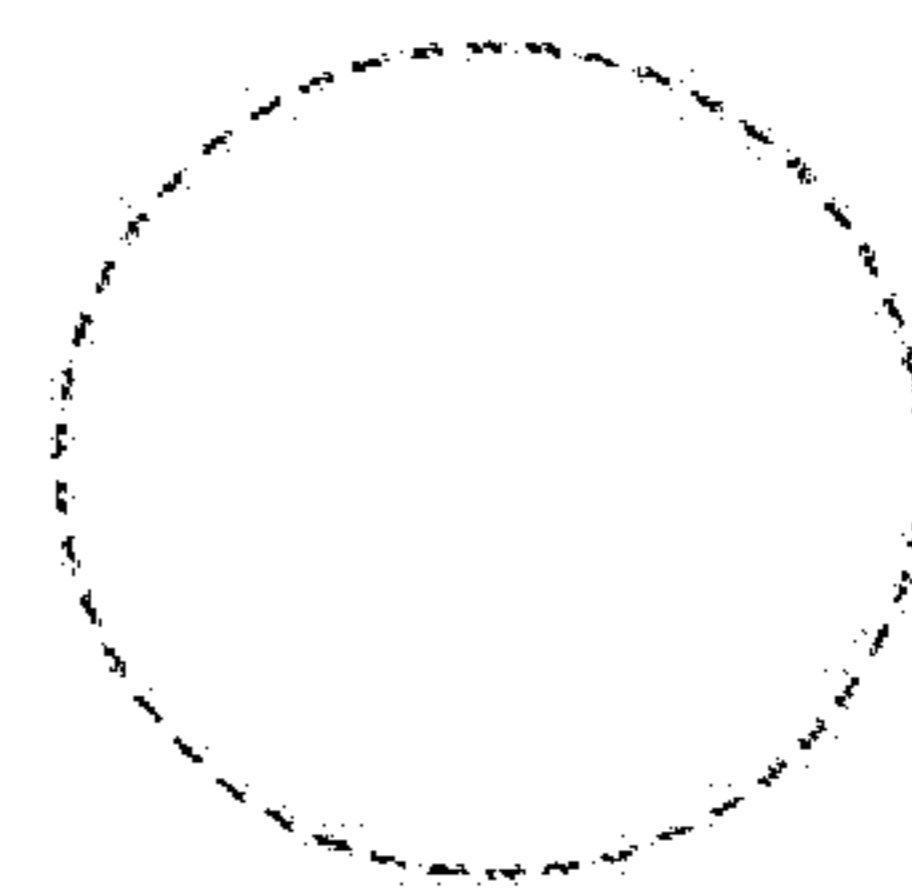

FIG. 6



FIG. 7



FIG. 8



FIG. 9

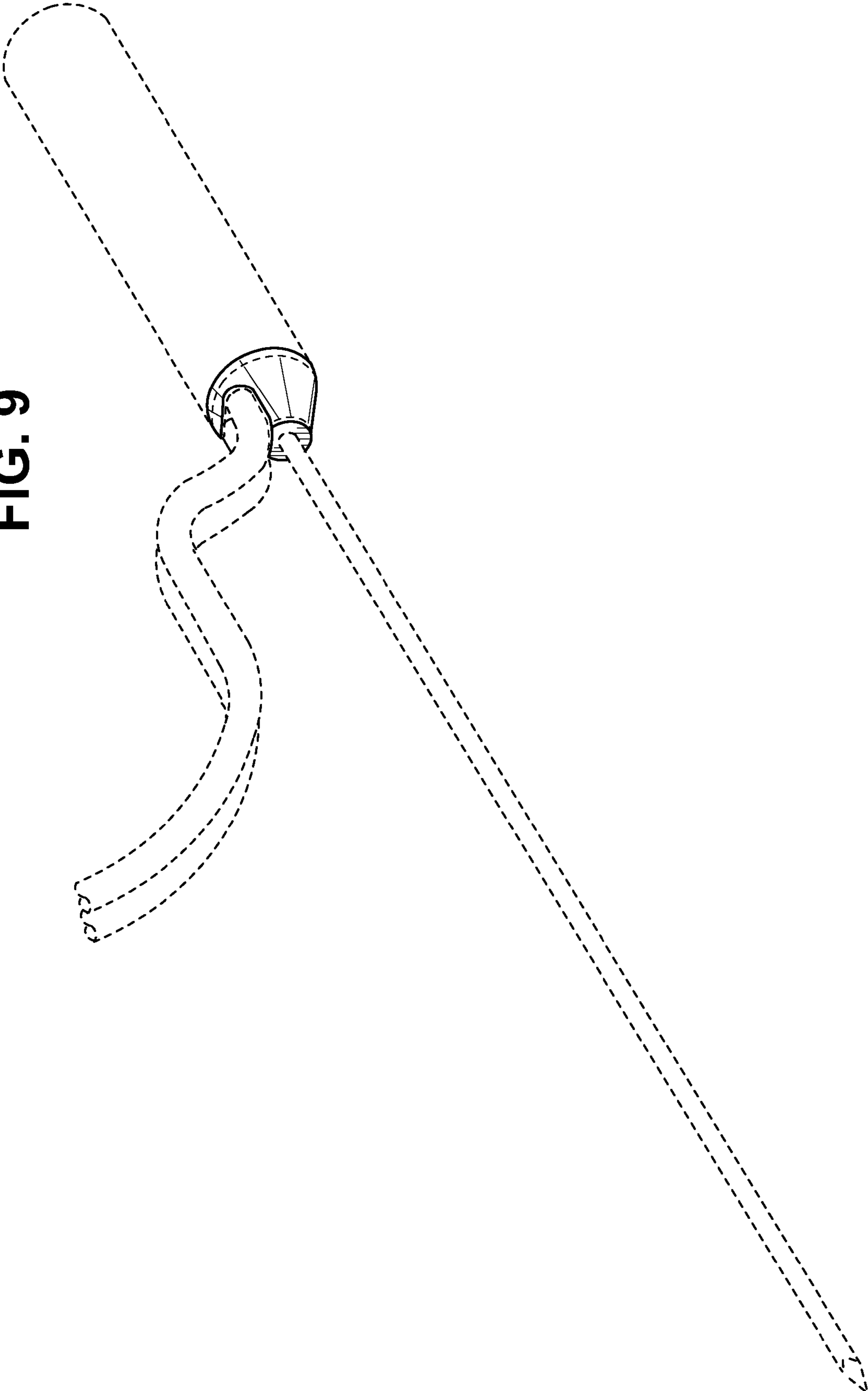

FIG. 10

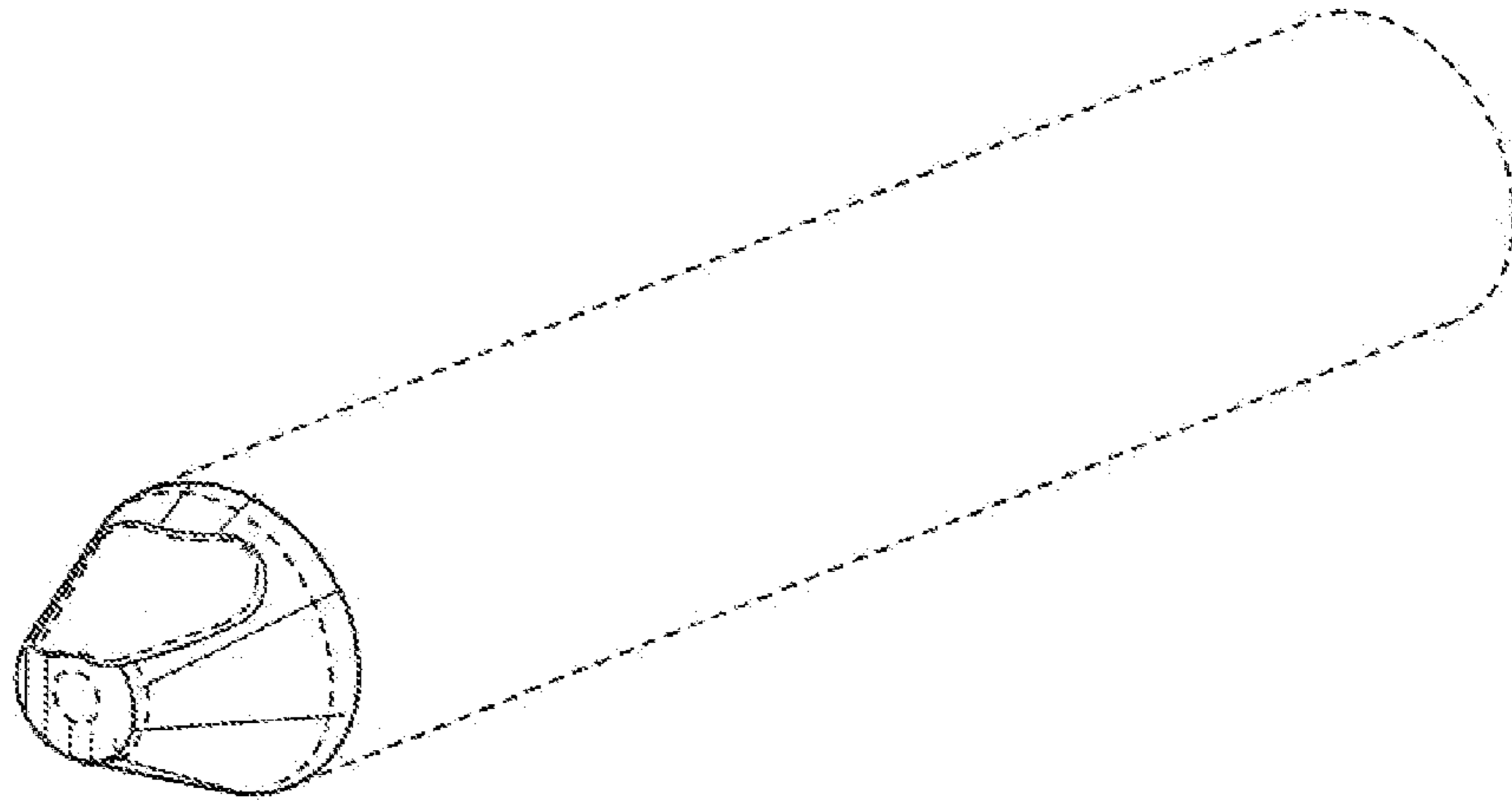

FIG. 11



FIG. 12

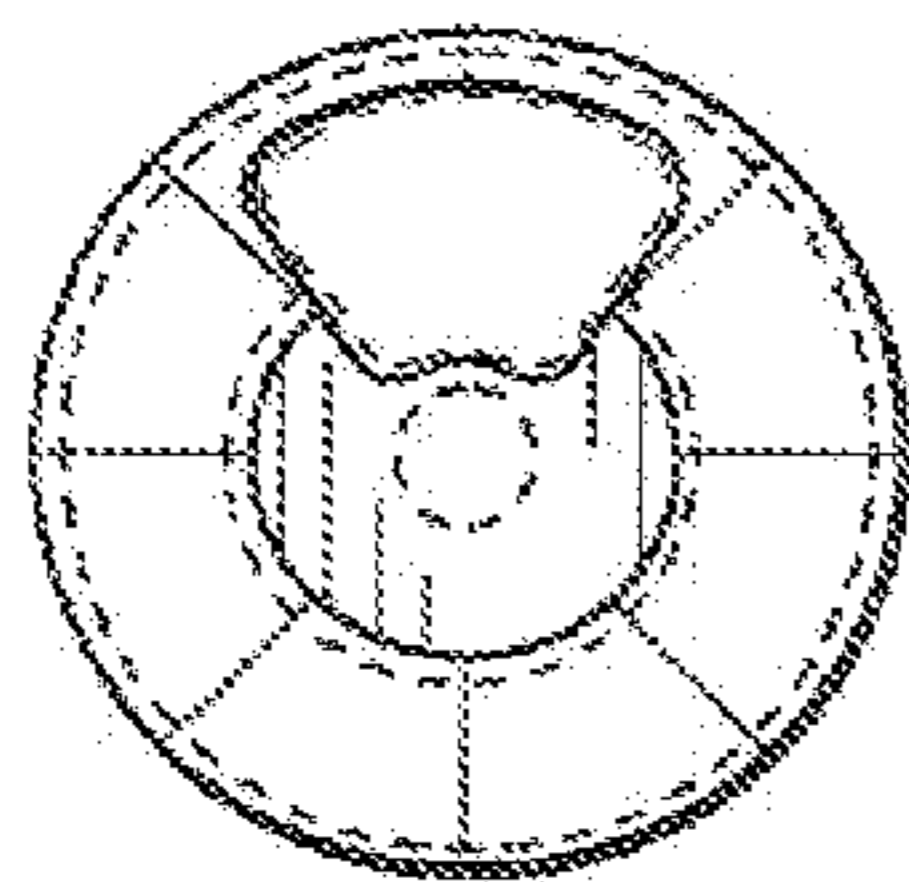

FIG. 13

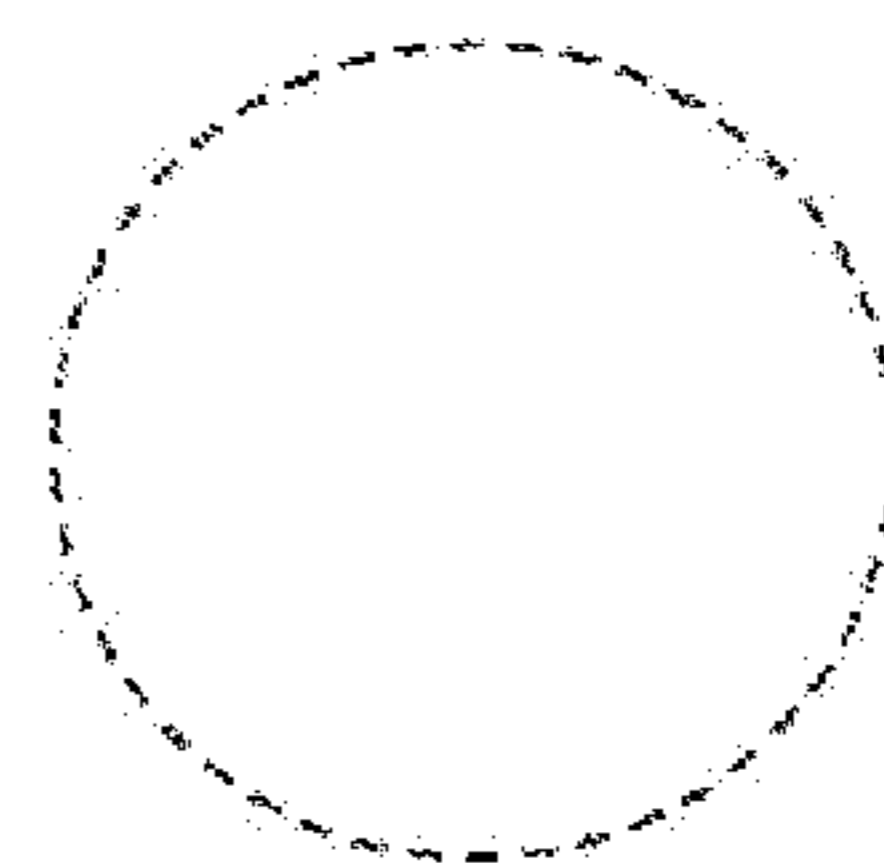

FIG. 14



FIG. 15



FIG. 16

