



US00D630616S

(12) **United States Design Patent**
Vex

(10) **Patent No.:** **US D630,616 S**

(45) **Date of Patent:** **** Jan. 11, 2011**

(54) **CUSTOMIZABLE STOMPBOX**

(75) **Inventor:** **Zachary Vex**, 2828 Dupont Ave. South,
Minneapolis, MN (US) 55408

(73) **Assignee:** **Zachary Vex**, Minneapolis, MN (US)

(**) **Term:** **14 Years**

(21) **Appl. No.:** **29/353,694**

(22) **Filed:** **Jan. 13, 2010**

(51) **LOC (9) Cl.** **14-01**

(52) **U.S. Cl.** **D14/217; D17/99**

(58) **Field of Classification Search** D14/162,
D14/167-169, 175, 188, 196-198, 217, 257,
D14/258, 496; D13/163, 164; 84/625, 660,
84/697; 455/350; D17/99

See application file for complete search history.

(56) **References Cited**

U.S. PATENT DOCUMENTS

- D236,212 S * 8/1975 Beigel et al. D17/99
- D244,215 S * 5/1977 Ross D14/217
- D343,826 S * 2/1994 Krebs et al. D13/168
- D376,365 S * 12/1996 Kawada D14/217
- D400,560 S * 11/1998 Ridinger D17/20
- D444,460 S * 7/2001 Kitazawa et al. D14/217
- D489,726 S * 5/2004 Takita et al. D14/433
- D500,493 S * 1/2005 Velazquez D14/217
- D518,086 S * 3/2006 Ito D17/99
- D520,553 S * 5/2006 Bogdan et al. D17/20

- D563,943 S * 3/2008 Watanabe D14/188
- D581,393 S * 11/2008 Rodrigues D14/188

OTHER PUBLICATIONS

- Box of Metal (2008 or before), by Zvex Effects, 1 page.
- Fuzzlab (2006 or before), by Beavis Audio, pp. 1-12.
- Three views of the ToneCrafter (2004 or before), by KillerTone Labs, 3 pages.
- ToneCore DSP Developer Kit (2008 or before), by Line 6, Inc, pp. 1-3.
- Beavis Board (2008 or before), by Beavis Audio, pp. 1-41.
- Ooh Wah II (2001 or before), by Zvex Effects, 1 page.
- Eventide Modfactor (2007 or before), by Eventide, Inc., 1 page.

* cited by examiner

Primary Examiner—Stella M Reid

Assistant Examiner—Keli L Hill

(74) *Attorney, Agent, or Firm*—Patterson Thuent
Christensen Pedersen, P.A.

(57) **CLAIM**

I claim the ornamental design for customizable stompbox, as shown.

DESCRIPTION

FIG. 1 is a top perspective view of a customizable stompbox, embodying my new design;

FIG. 2 bottom perspective view thereof;

FIG. 3 is an alternate bottom perspective view thereof; and,

FIG. 4 is an alternate top perspective view thereof.

1 Claim, 2 Drawing Sheets

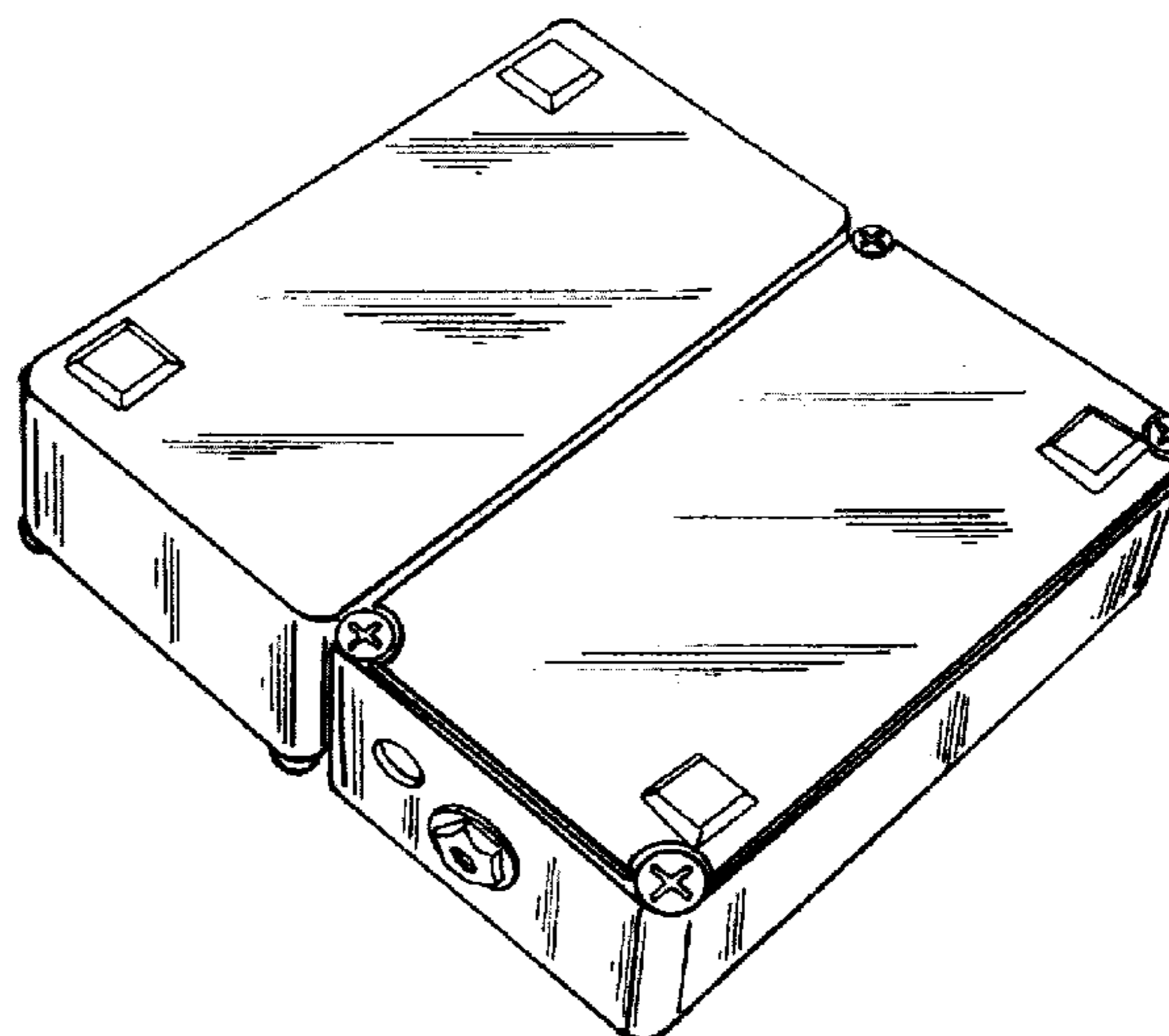
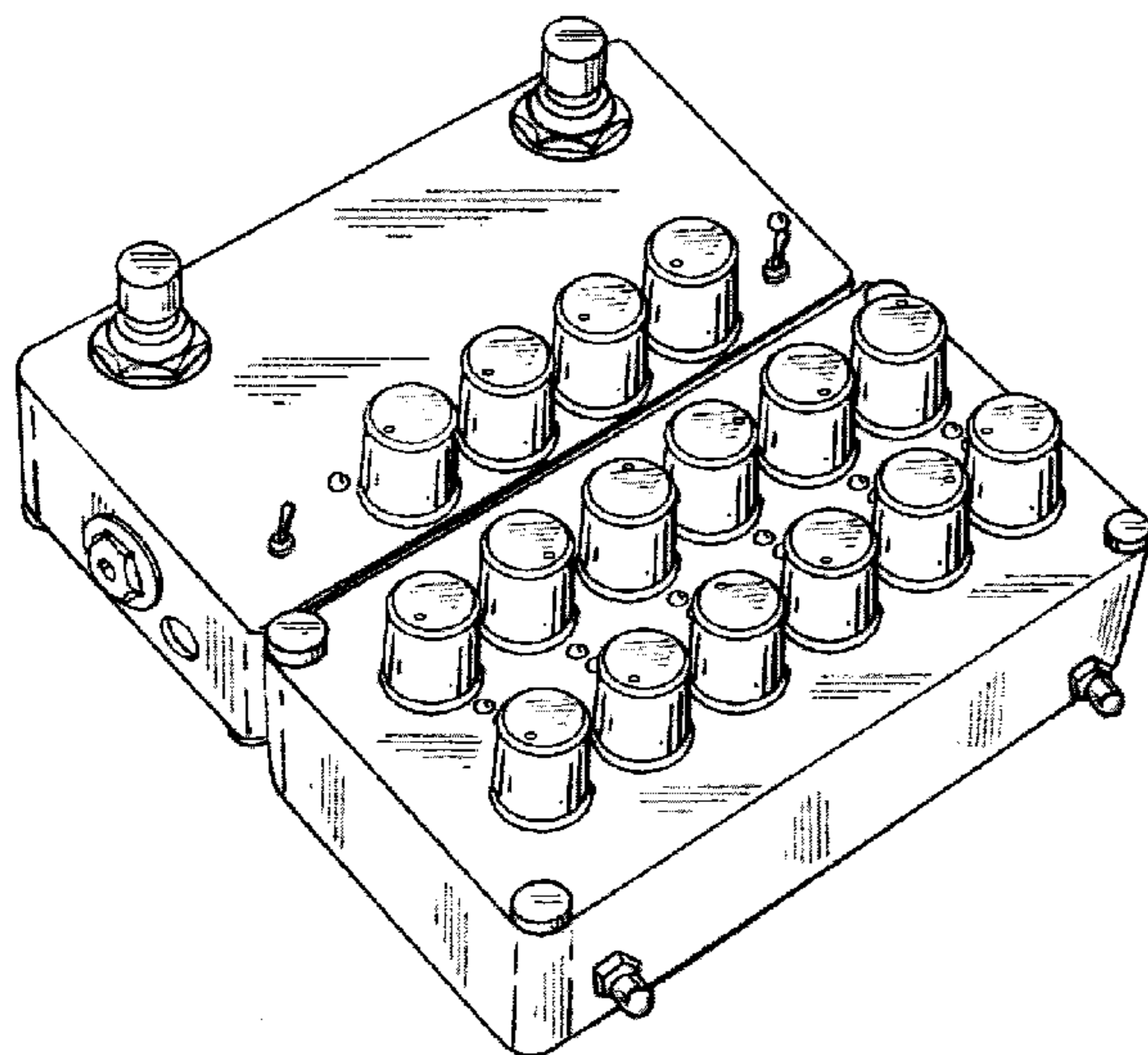

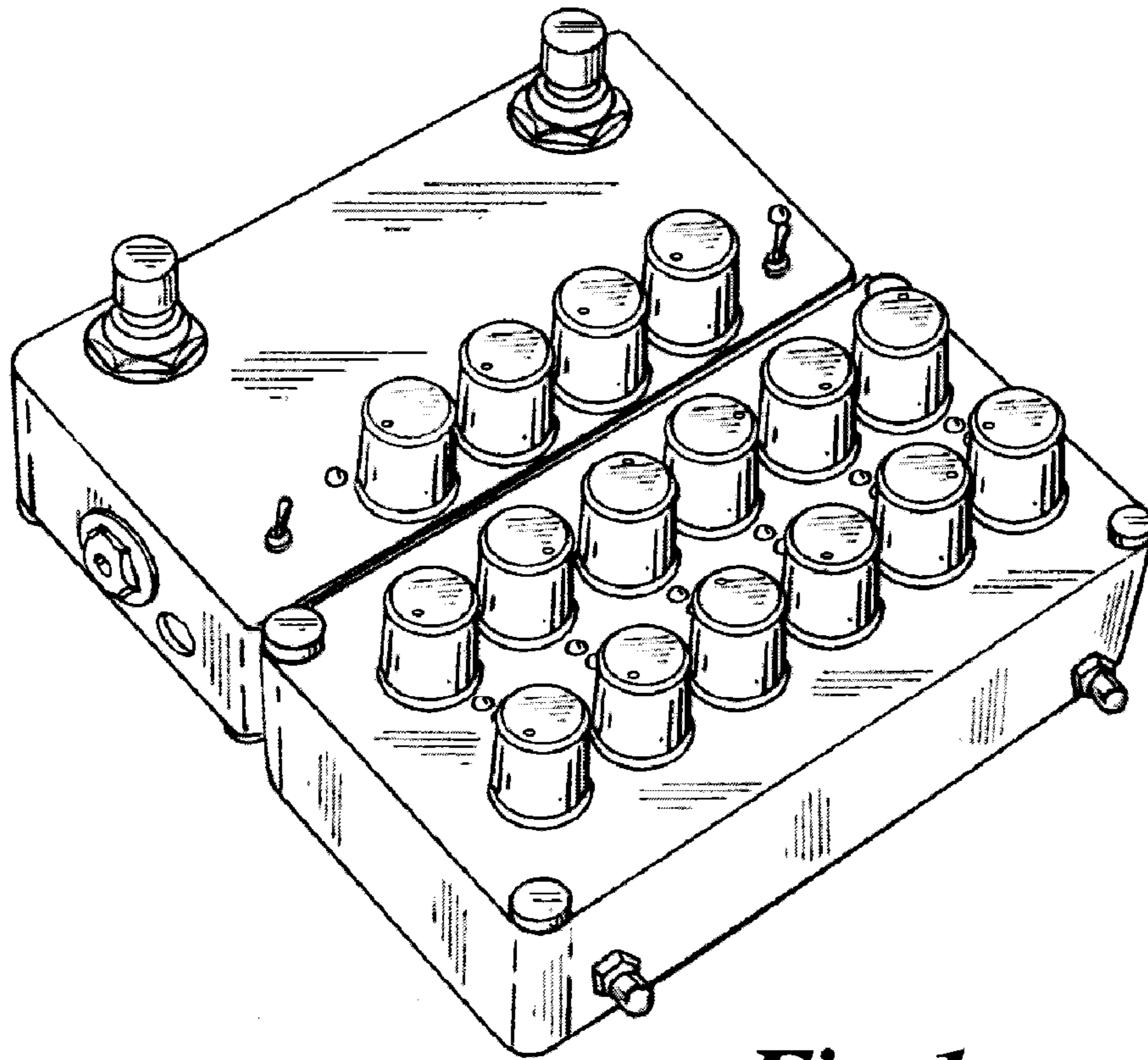

Fig. 1

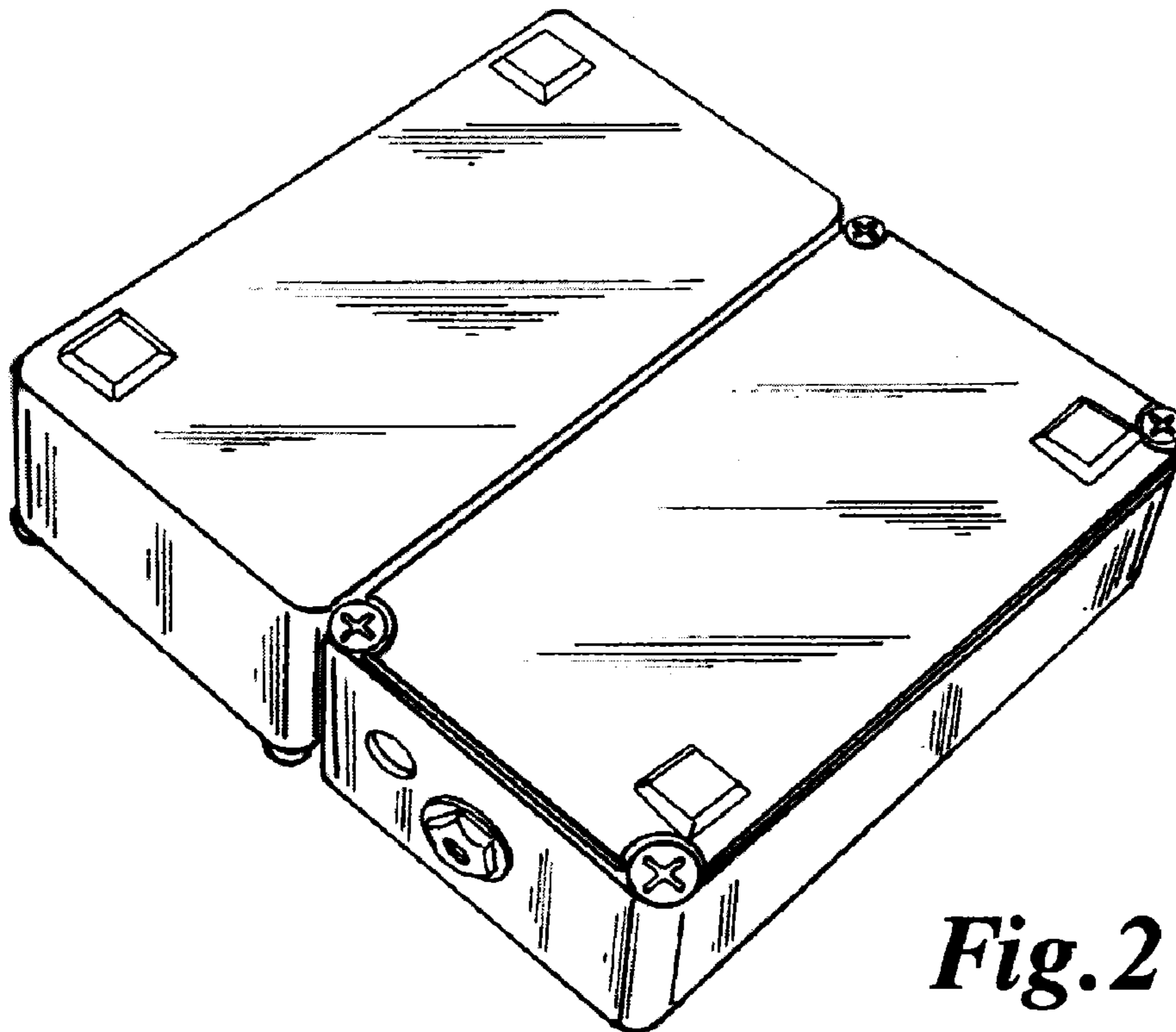

Fig. 2

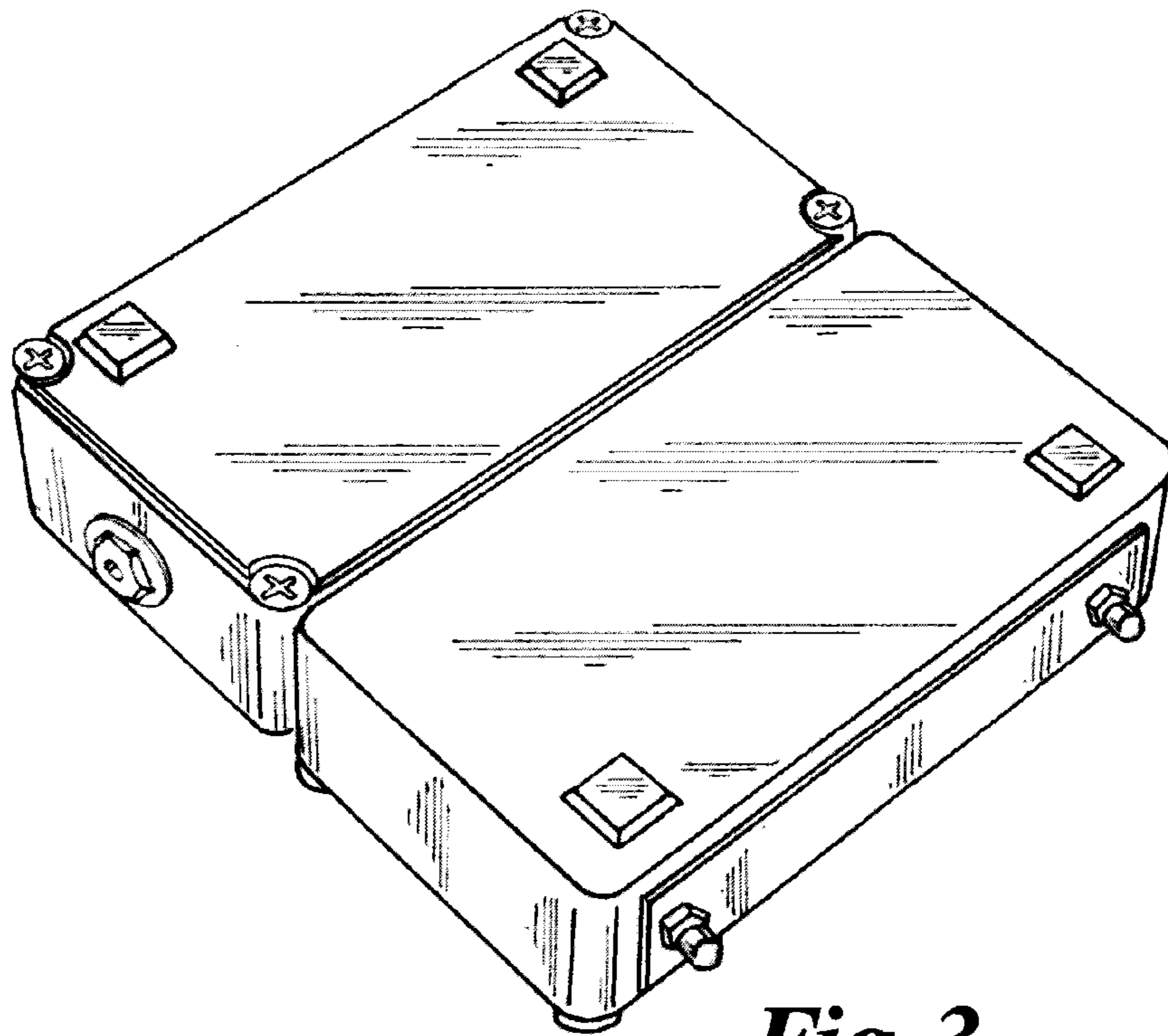

Fig. 3

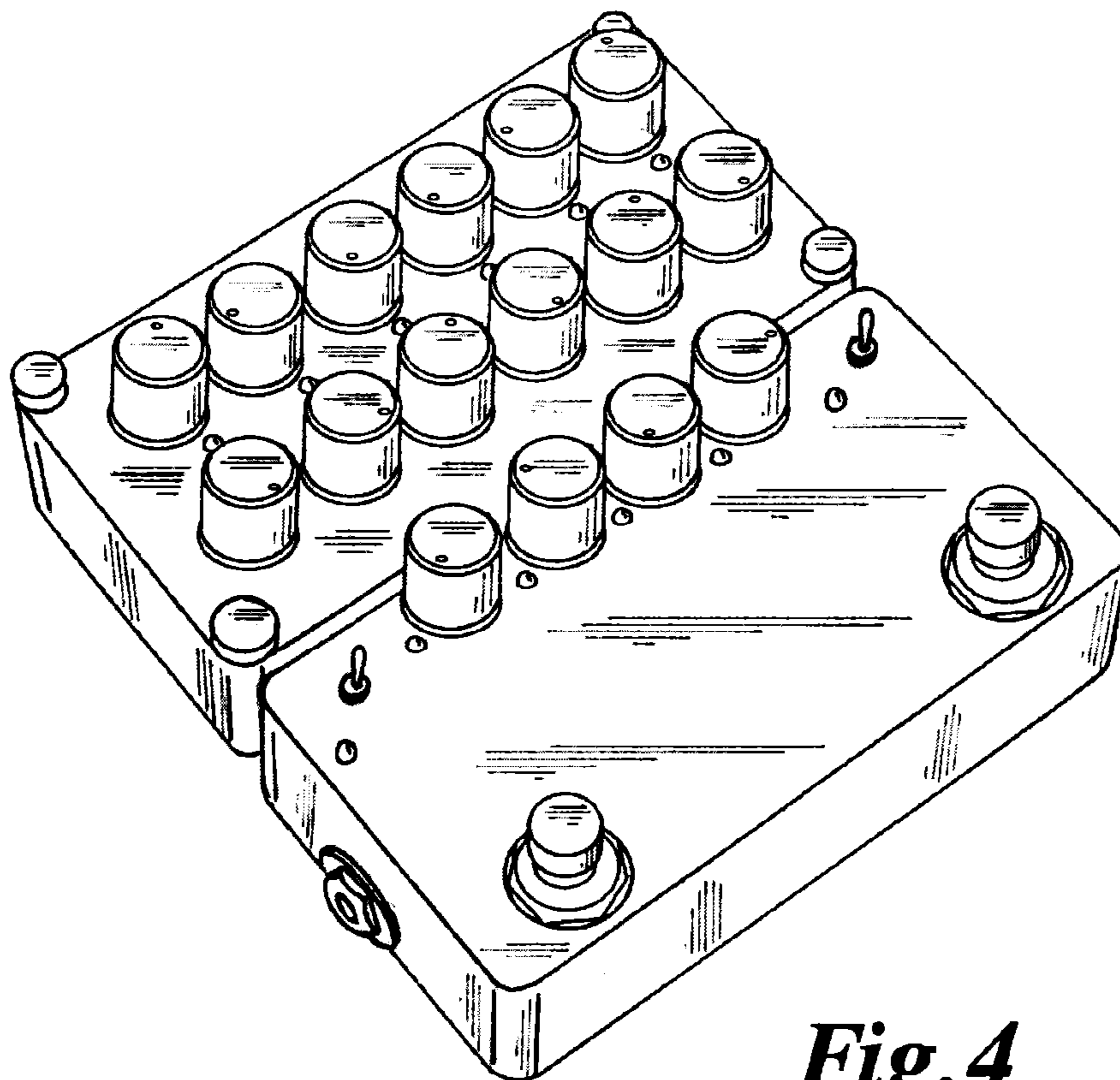

Fig. 4