



US00D630532S

(12) **United States Design Patent**
Johnson et al.

(10) **Patent No.:** **US D630,532 S**
(45) **Date of Patent:** **** Jan. 11, 2011**

(54) **PORTION CONTROL MEASURING DEVICES AND BASE UNIT SET**

(75) Inventors: **Kevin D. Johnson**, Tarzana, CA (US);
Steven Kates, Los Angeles, CA (US);
Myles Berkowitz, Los Angeles, CA (US)

(73) Assignee: **LifeSize, LLC**, Los Angeles, CA (US)

(**) Term: **14 Years**

(21) Appl. No.: **29/329,988**

(22) Filed: **Dec. 24, 2008**

(51) **LOC (9) Cl.** **10-04**

(52) **U.S. Cl.** **D10/46.2; D7/688; D7/691**

(58) **Field of Classification Search** D10/46.2-46.3;
D7/505, 543, 545, 587, 590, 600.1, 601, 300,
D7/605, 637-638, 688, 691, 693, 368, 213;
73/426-429; 30/324-328; 294/55

See application file for complete search history.

(56) **References Cited**

U.S. PATENT DOCUMENTS

D192,018 S *	1/1962	McLeod	D7/688
D328,492 S *	8/1992	Mathis	D24/121
D330,863 S *	11/1992	Green	D10/46.2
D394,217 S *	5/1998	Laib	D10/46.2
D402,512 S *	12/1998	Lee et al.	D7/600.1
D440,501 S *	4/2001	Dorion et al.	D10/46.2
D463,223 S *	9/2002	Bien	D7/696
D486,745 S *	2/2004	Mastroianni	D10/46.2
D495,964 S *	9/2004	Overthun et al.	D10/46.2
D509,403 S *	9/2005	Raydo	D7/361
D521,398 S *	5/2006	DiPietro et al.	D10/46.2
D528,874 S *	9/2006	Iacchetti et al.	D7/669
D588,947 S *	3/2009	Curtin	D10/46.2

* cited by examiner

Primary Examiner—Carol Rademaker

Assistant Examiner—Dana L Sipos

(74) *Attorney, Agent, or Firm*—Dorsey & Whitney LLP

(57) **CLAIM**

We claim the ornamental design for a set of portion control measuring devices and a base unit set, as shown and described.

DESCRIPTION

FIG. 1 is a top, front, right side perspective view of a portion control measuring devices and base unit set showing our new design;

FIG. 2 is a front elevation view thereof;

FIG. 3 is a rear elevation view thereof;

FIG. 4 is a right side elevation view thereof, shown at an enlarged scale;

FIG. 5 is a left side elevation view thereof;

FIG. 6 is a top plan view thereof, shown at reduced scale;

FIG. 7 is a bottom plan view thereof;

FIG. 8 is a top, front, right side perspective view of the base unit portion of the portion control measuring devices and base unit set of FIG. 1;

FIG. 9 is a front elevation view thereof;

FIG. 10 is a rear elevation view thereof;

FIG. 11 is a right side elevation view thereof, shown at an enlarged scale;

FIG. 12 is a left side elevation view thereof;

FIG. 13 is a top plan view thereof, shown at a reduced scale;

FIG. 14 is a bottom plan view thereof;

FIG. 15 is a is a top, front, right side perspective view of the large round measuring spoon element of the portion control measuring devices and base unit set of FIG. 1;

FIG. 16 is a right side elevation view thereof, the left side elevation view being a mirror image;

FIG. 17 is a top plan view thereof;

FIG. 18 is a bottom plan view thereof;

FIG. 19 is a rear elevation view thereof;

FIG. 20 is a front elevation view thereof;

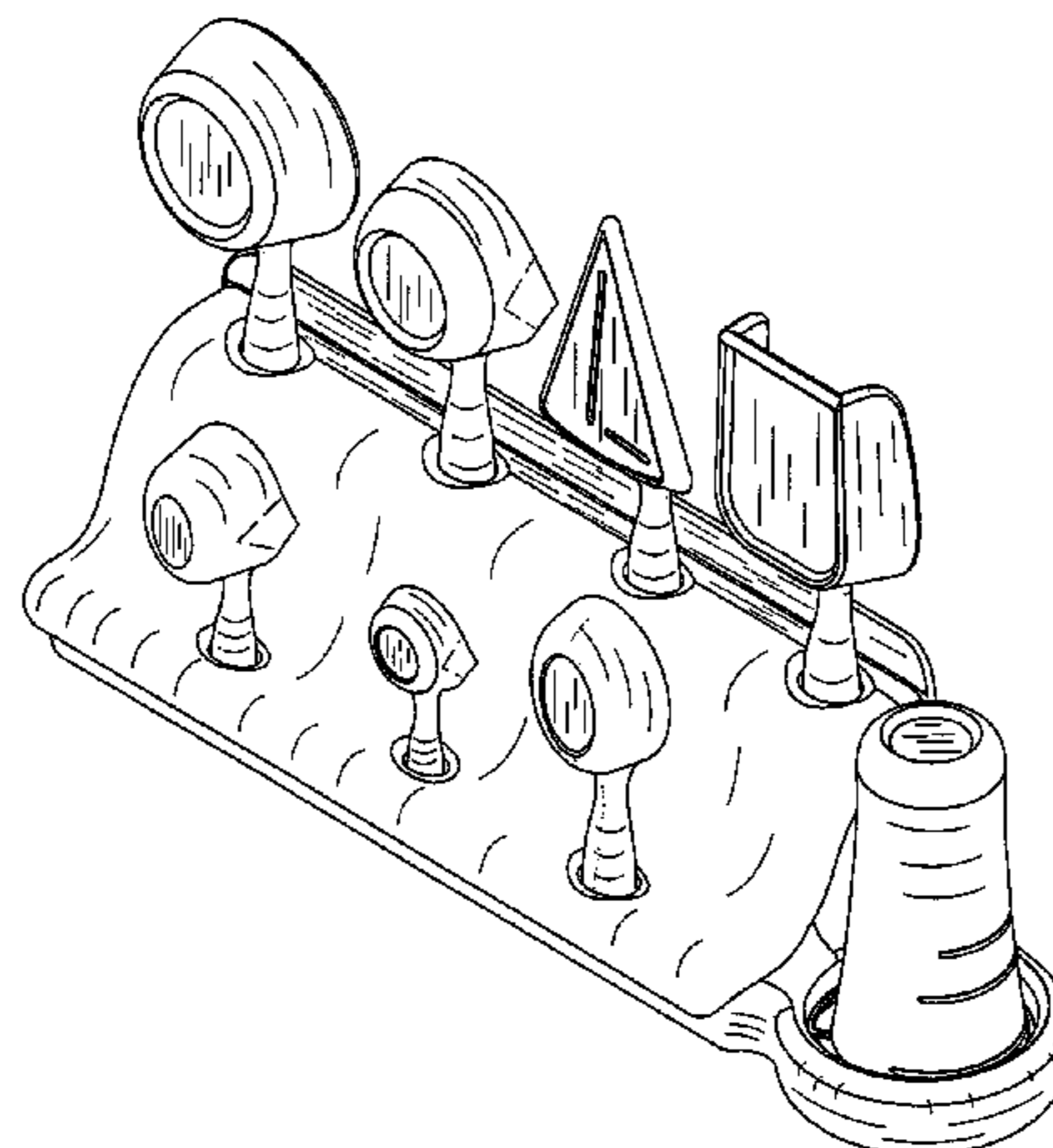

FIG. 21 is a top, front, right side perspective view of the small, oval, dual pour spout measuring spoon element of the portion control measuring devices and base unit set of FIG. 1;

FIG. 22 is a left side elevation view thereof, the right side elevation view being a mirror image;

FIG. 23 is a top plan view thereof;

FIG. 24 is a bottom plan view thereof;

FIG. 25 is a rear elevation view thereof, shown at an enlarged scale;

FIG. 26 is a front elevation view thereof;

FIG. 27 is a top, rear, right side perspective view of the measuring scoop element of the portion control measuring devices and base unit set of FIG. 1;

FIG. 28 is a top plan view thereof;

FIG. 29 is a bottom plan view thereof;

FIG. 30 is a left side elevation view thereof, the right side elevation view being a mirror image;

FIG. 31 is a rear elevation view thereof, shown at an enlarged scale;

FIG. 32 is a front elevation view thereof;

FIG. 33 is a top, front, right side perspective view of the large, round, dual pour spout measuring spoon element of the portion control measuring devices and base unit set of FIG. 1, the small round dual pour spout measuring spoon element being identical but reduced in proportion;

FIG. 34 is a right side elevation view thereof, the left side elevation view being a mirror image;

FIG. 35 is a top plan view thereof;

FIG. 36 is a bottom plan view thereof;

FIG. 37 is a rear elevation view thereof, shown at an enlarged scale;

FIG. 38 is a front elevation view thereof;

FIG. 39 is a top, front, right side perspective view of the oval measuring spoon element of the portion control measuring devices and base unit set of FIG. 1;

FIG. 40 is a top plan view thereof;

FIG. 41 is a bottom plan view thereof;

FIG. 42 is a right side elevation view thereof, the left side elevation view being a mirror image;

FIG. 43 is a rear elevation view thereof, shown at an enlarged scale;

FIG. 44 is a front elevation view thereof;

FIG. 45 is a bottom, rear, right side perspective view of the triangular measuring spatula element of the portion control measuring devices and base unit set of FIG. 1;

FIG. 46 is a bottom plan view thereof;

FIG. 47 is a top plan view thereof;

FIG. 48 is a left side elevation view thereof, the right side elevation view being a mirror image;

FIG. 49 is a rear elevation view thereof, shown at an enlarged scale;

FIG. 50 is a front elevation view thereof;

FIG. 51 is a top, rear, right side perspective view of the measuring cup element of the portion control measuring devices and base unit set of FIG. 1;

FIG. 52 is a right side elevation view thereof;

FIG. 53 is a rear elevation view thereof;

FIG. 54 is a front elevation view thereof;

FIG. 55 is a top plan view thereof; and,

FIG. 56 is a bottom plan view thereof.

1 Claim, 50 Drawing Sheets

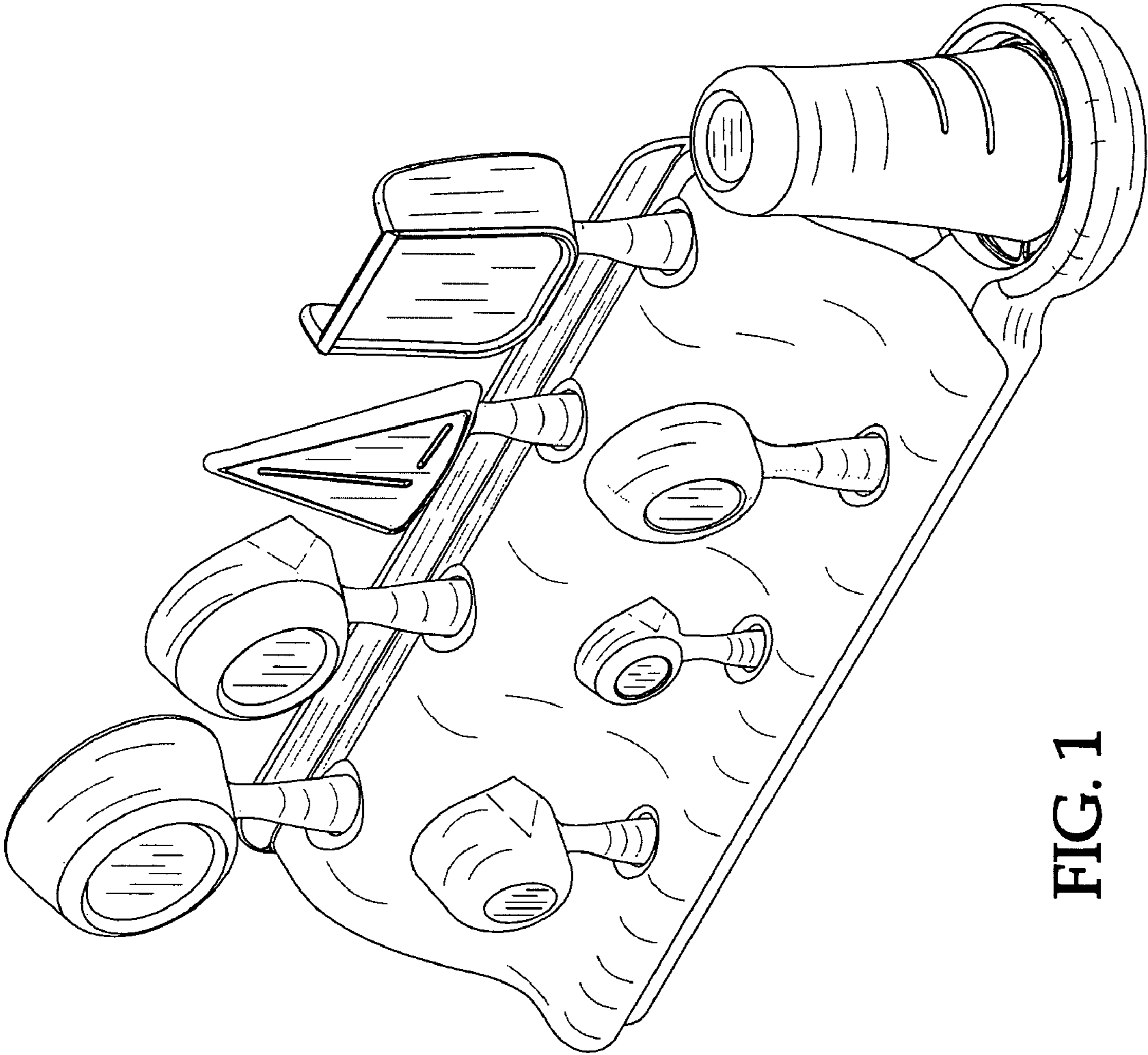

FIG. 1

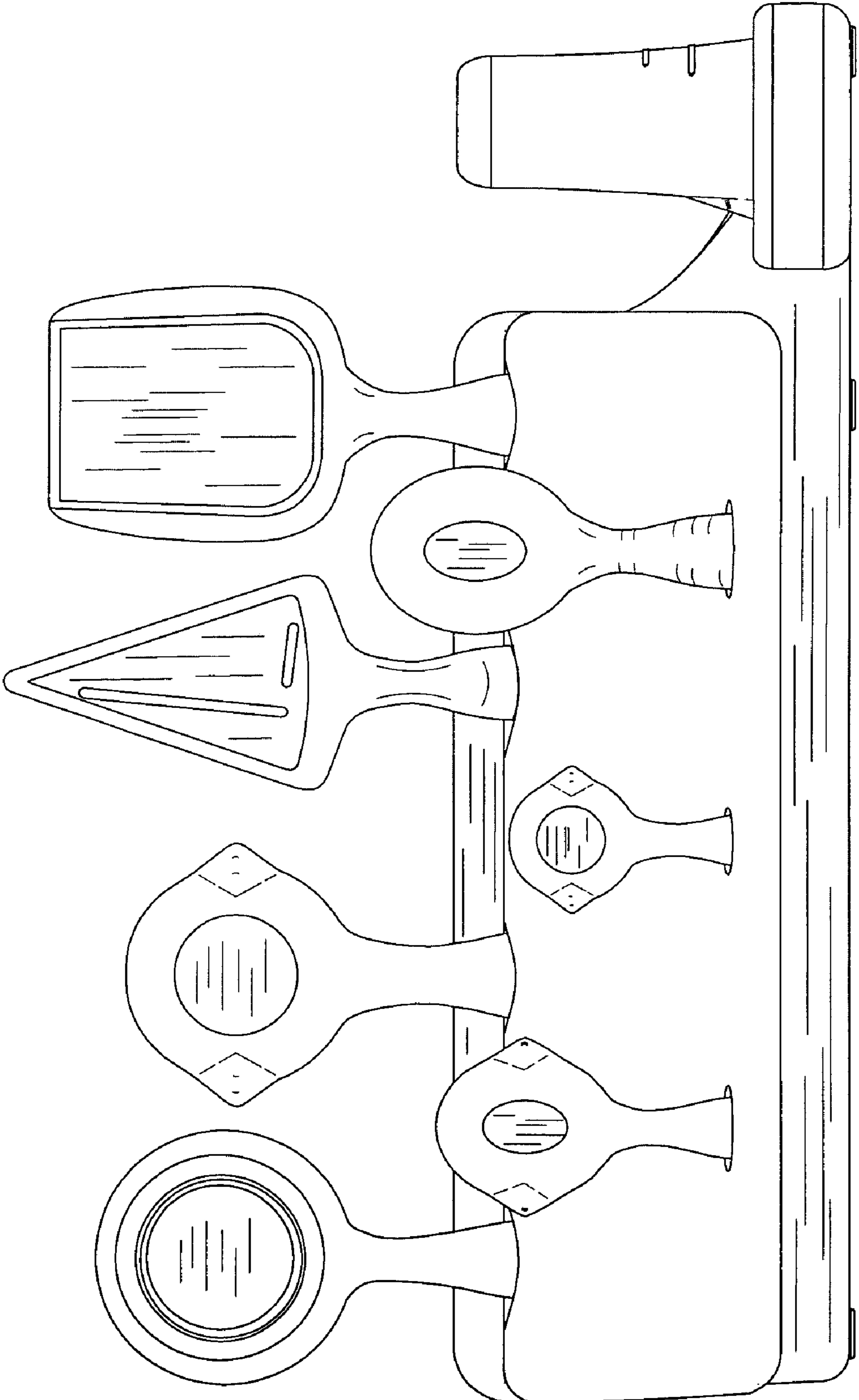

FIG. 2

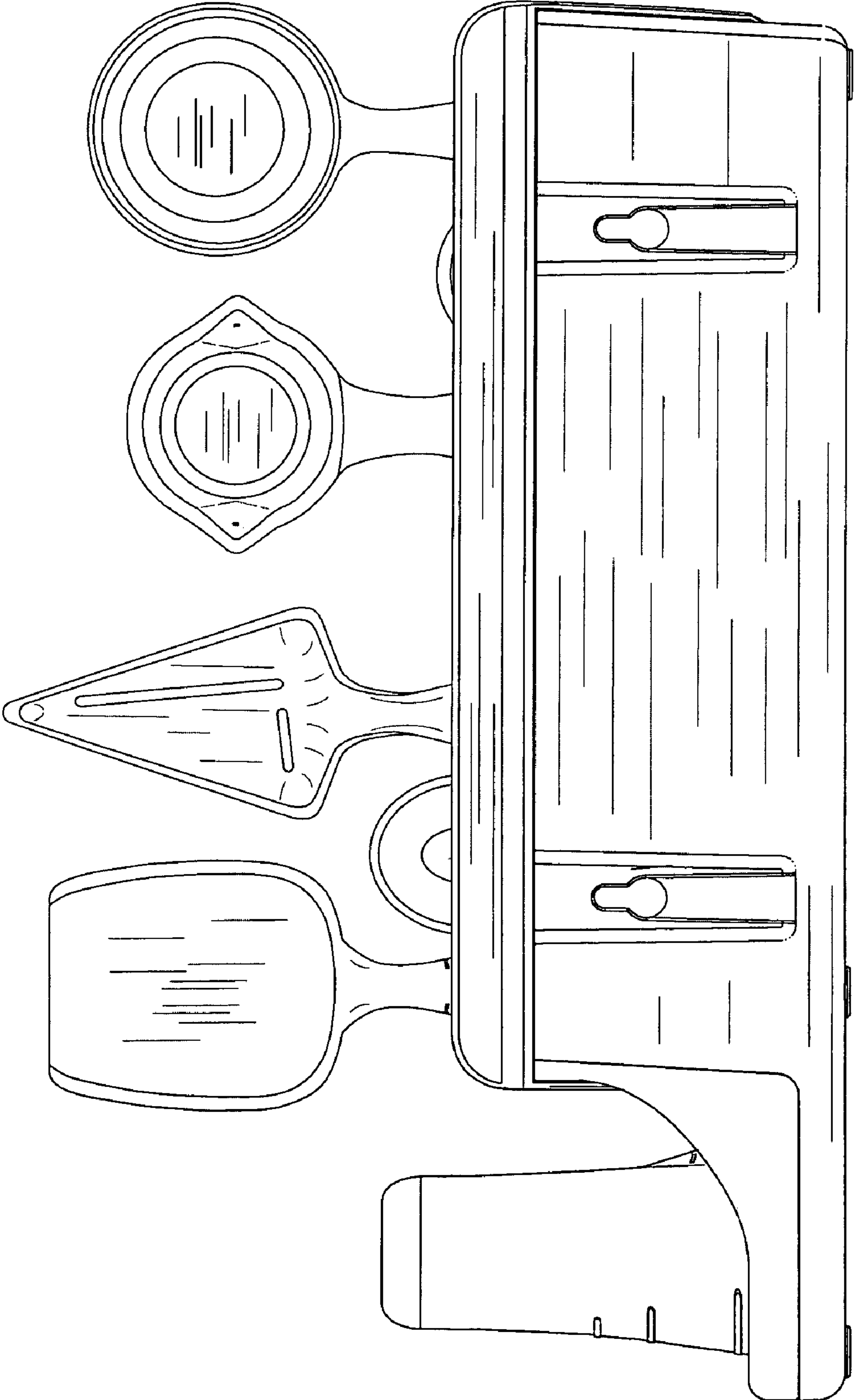

FIG. 3

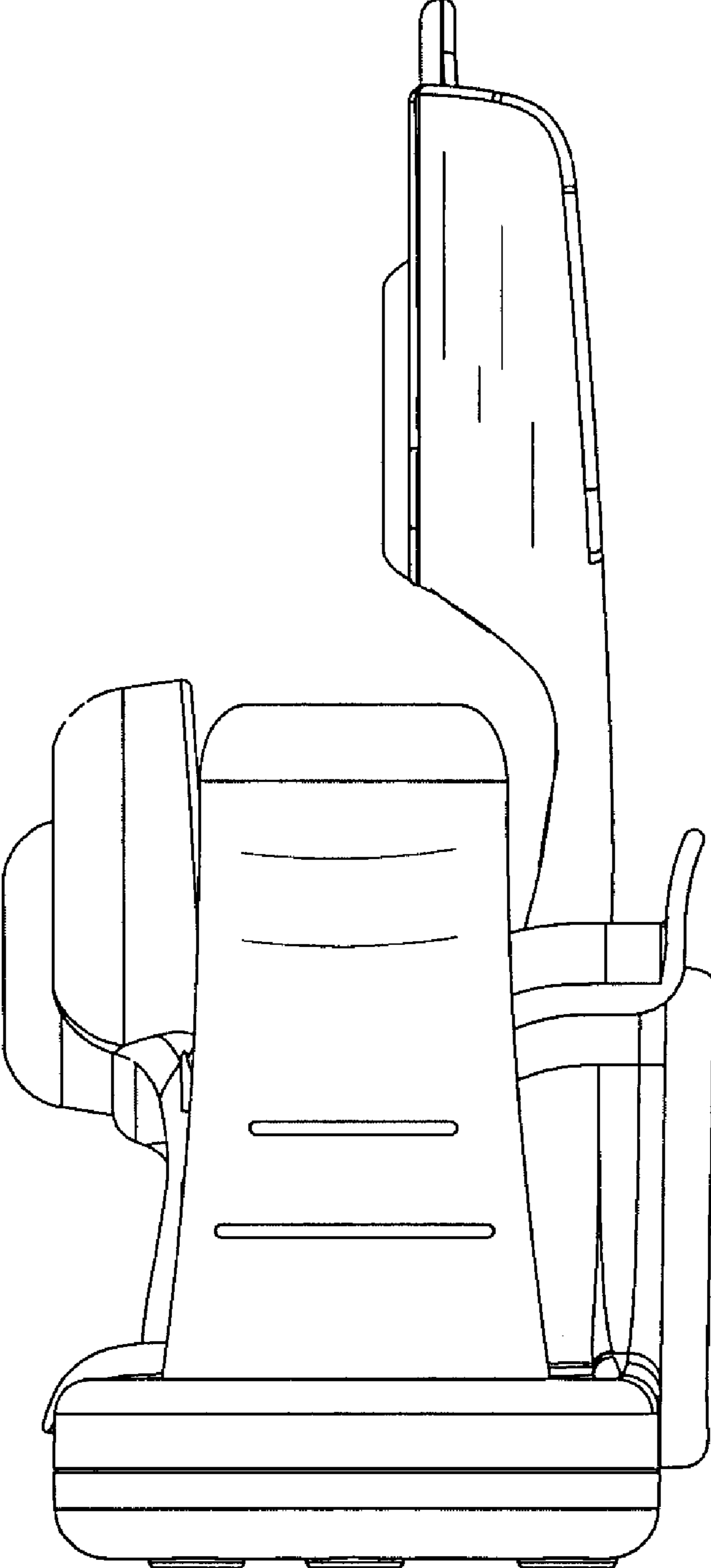

FIG. 4

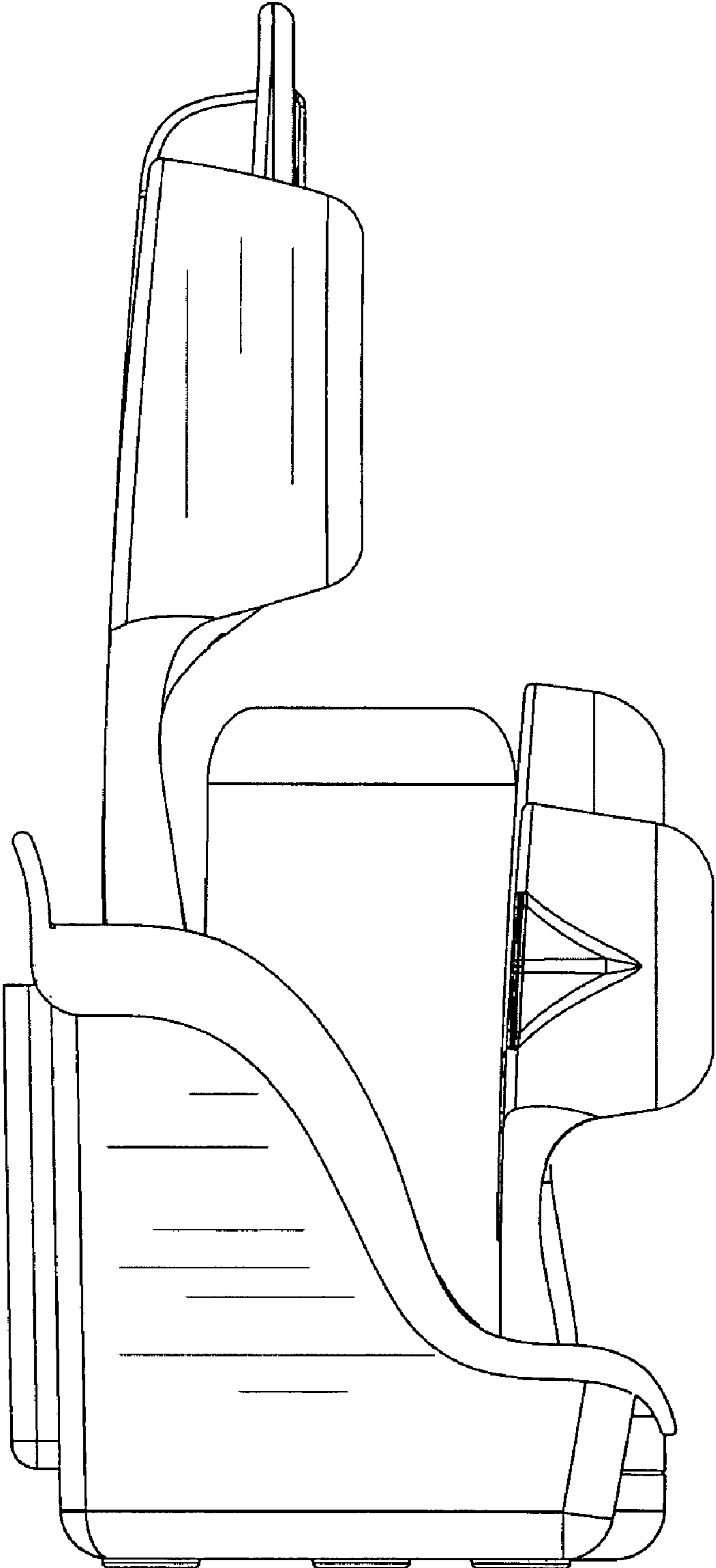

FIG. 5

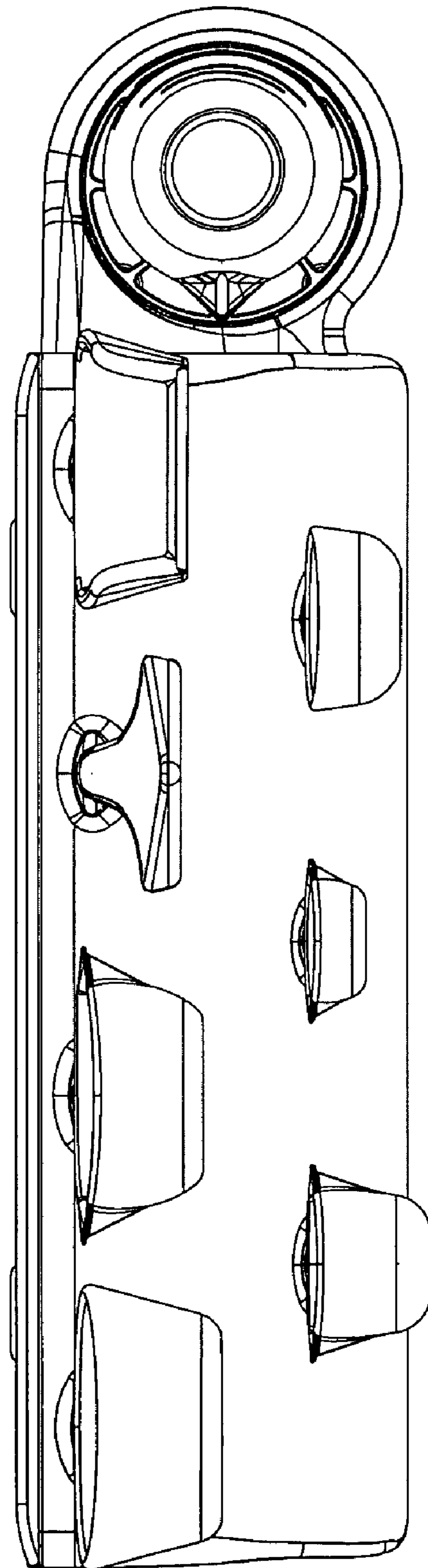

FIG. 6

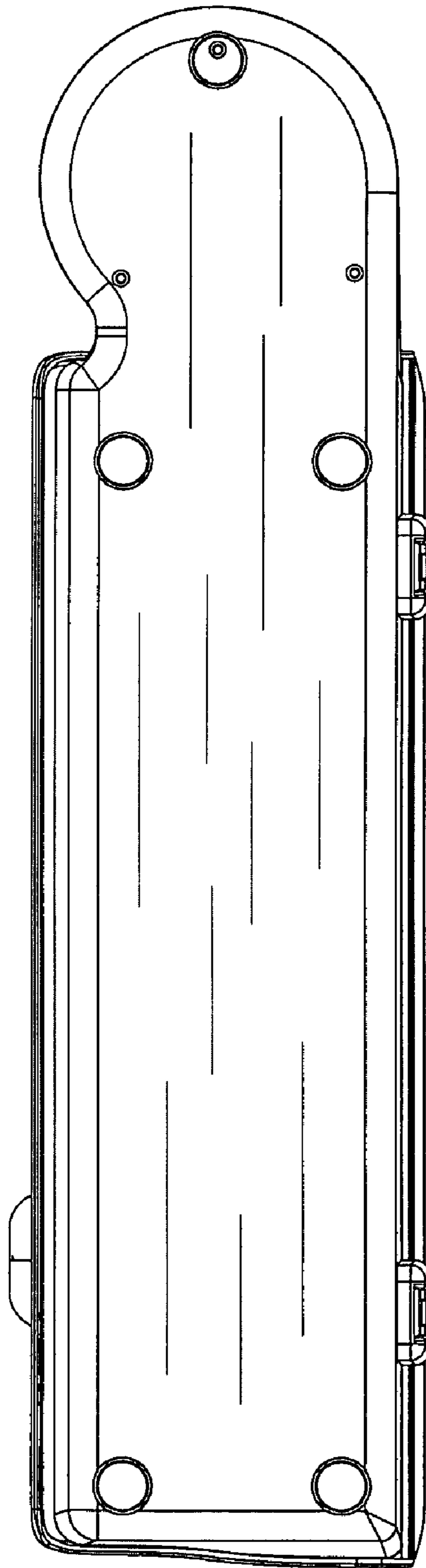

FIG. 7

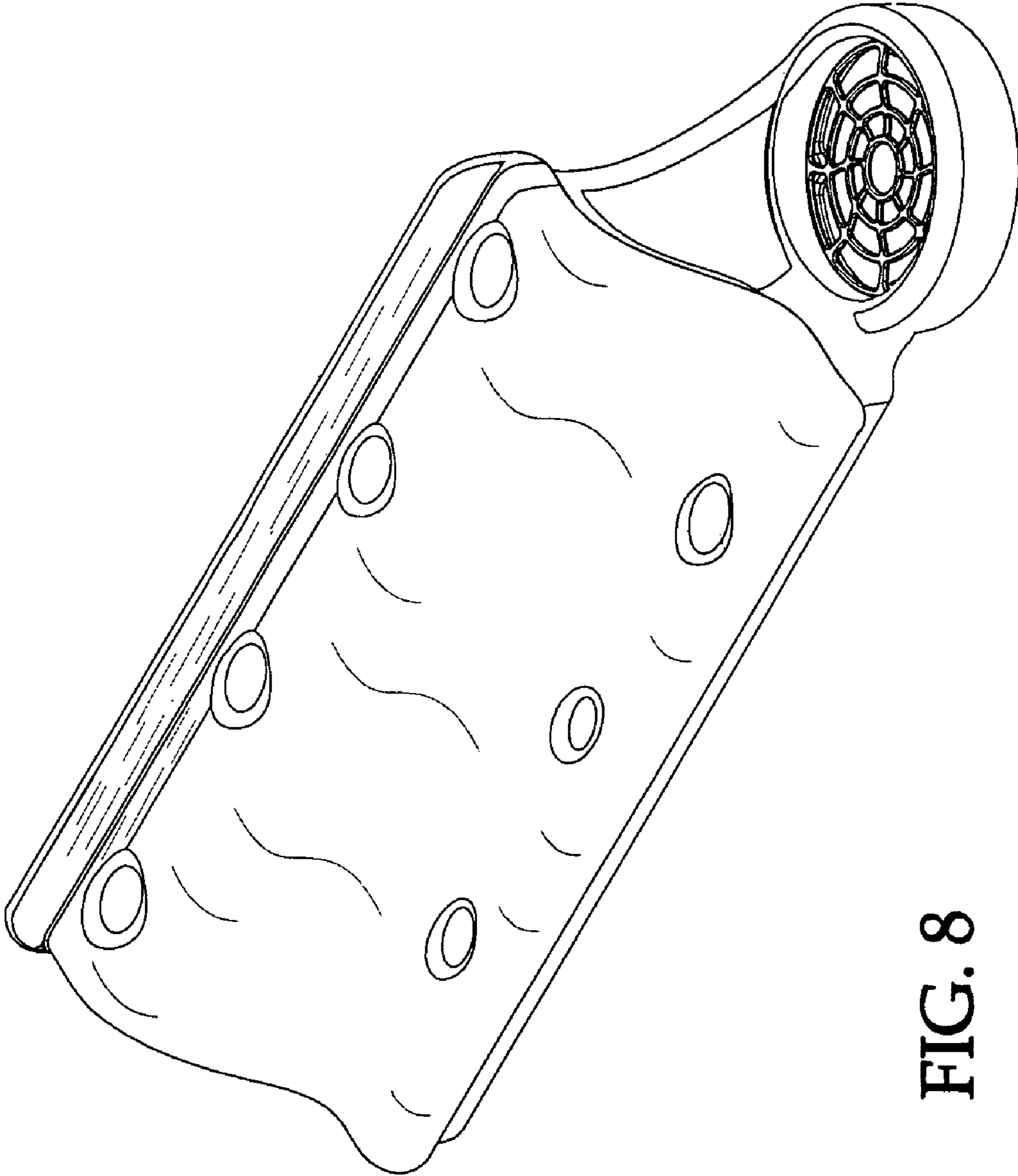

FIG. 8

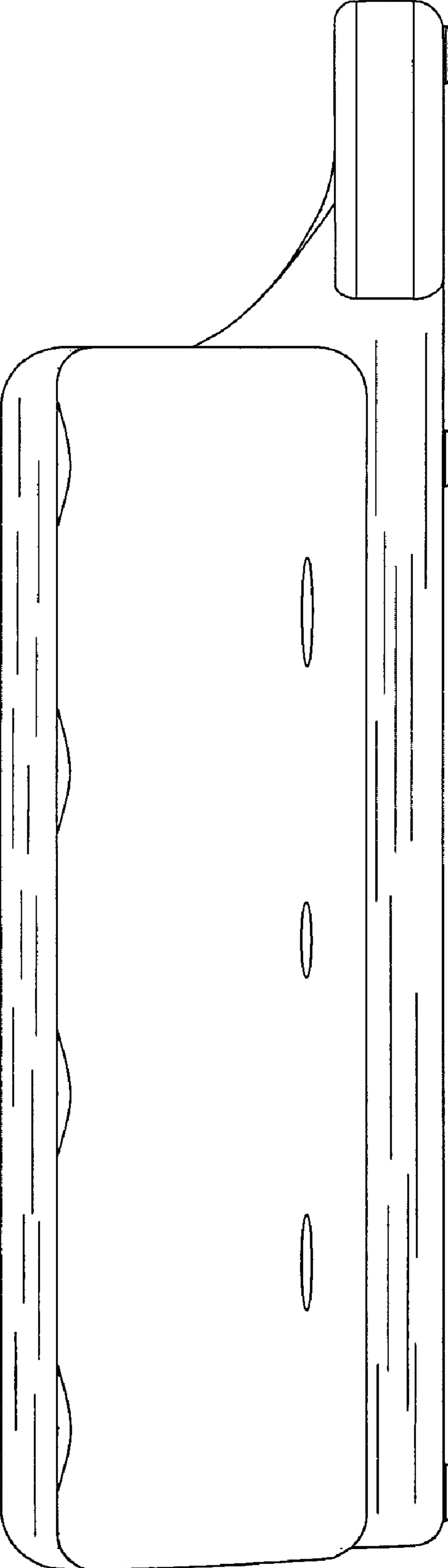

FIG. 9

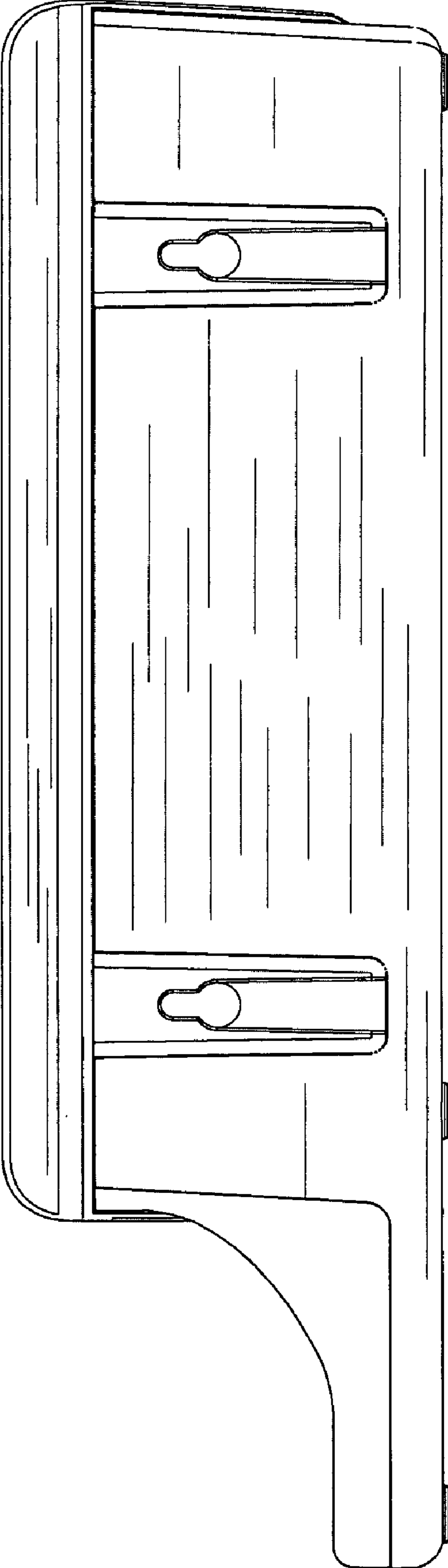

FIG. 10

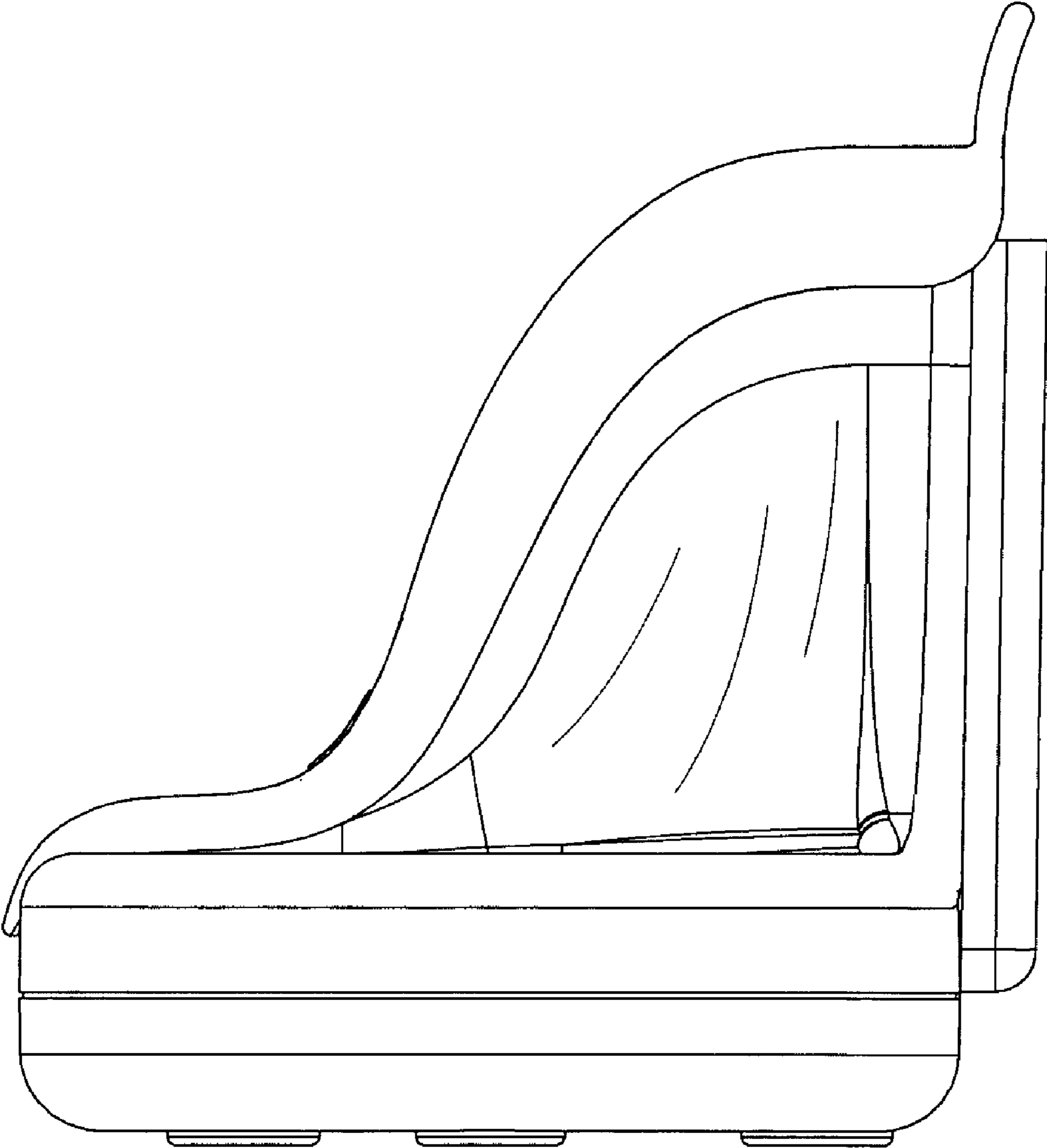

FIG. 11

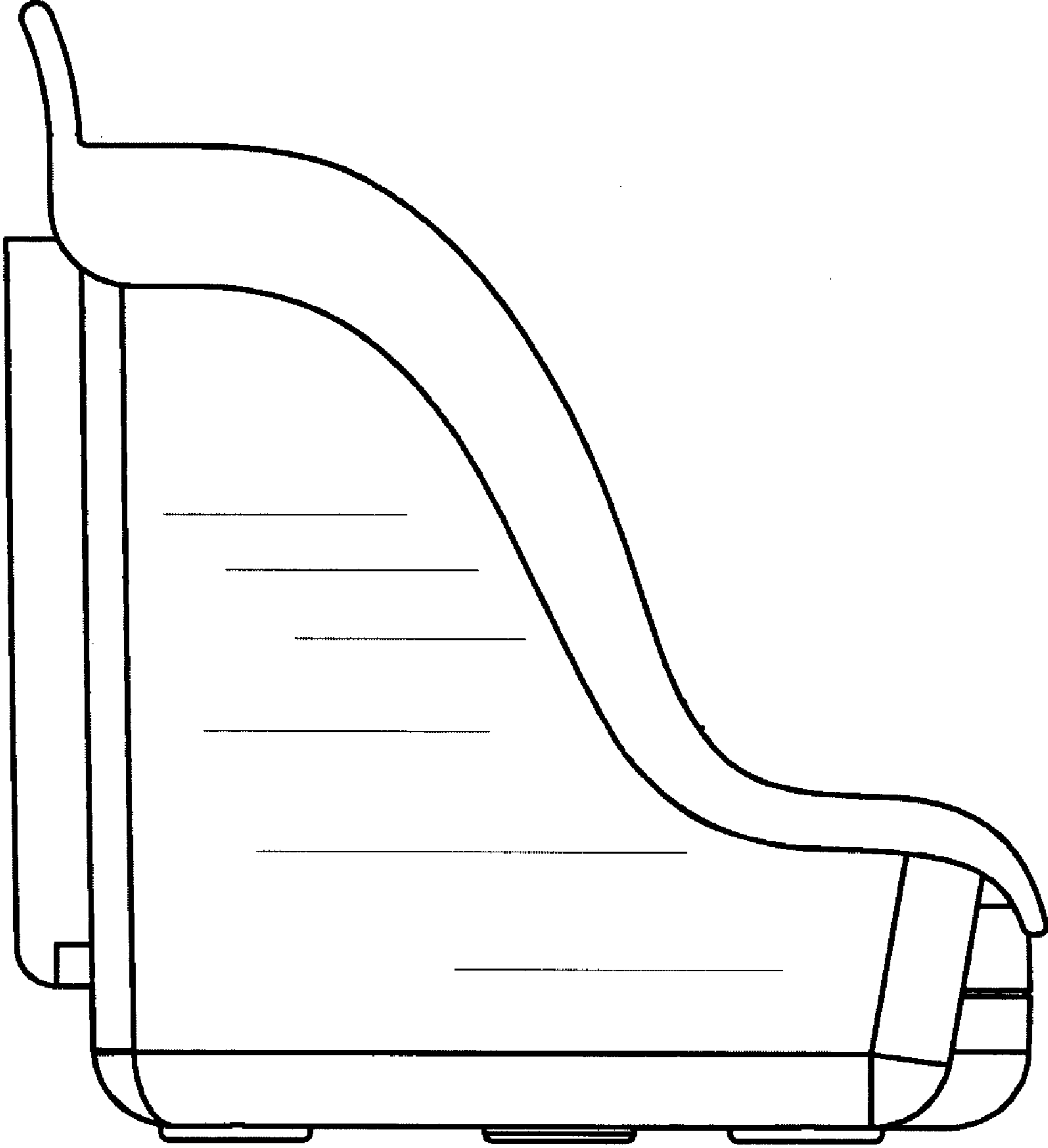

FIG. 12

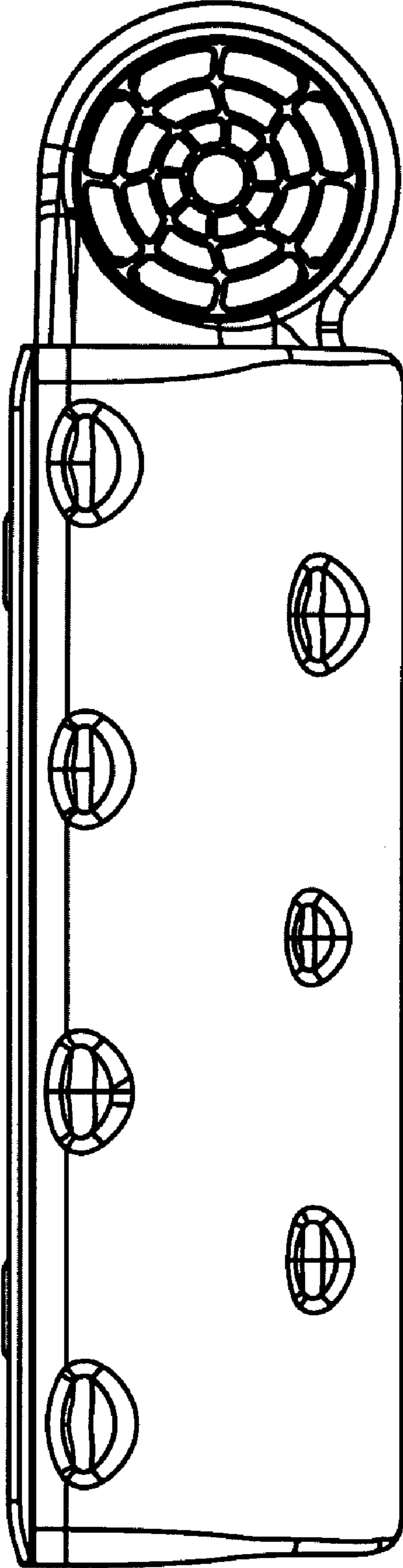

FIG. 13

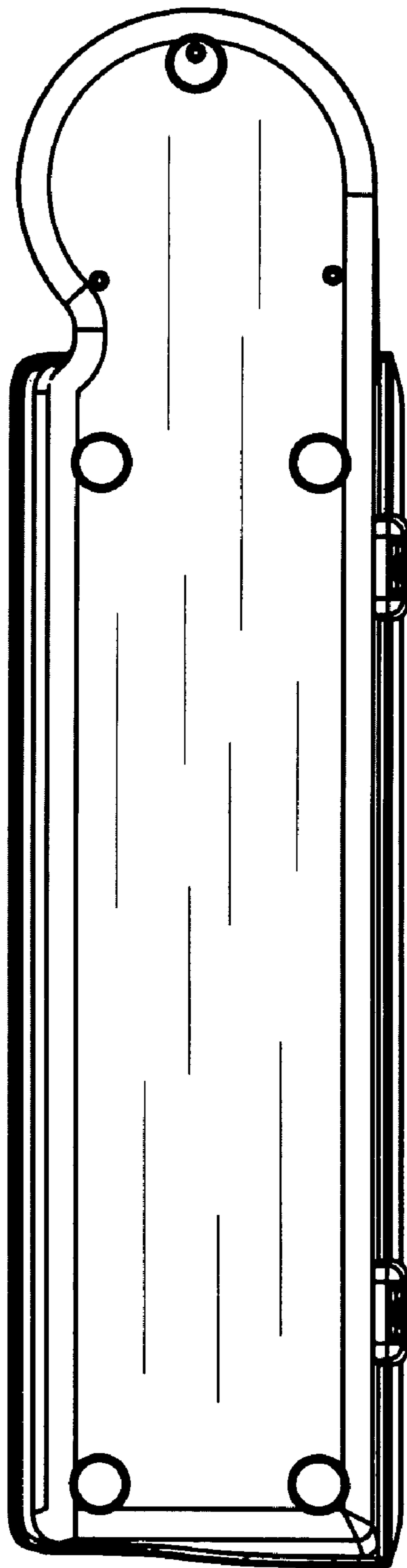

FIG. 14

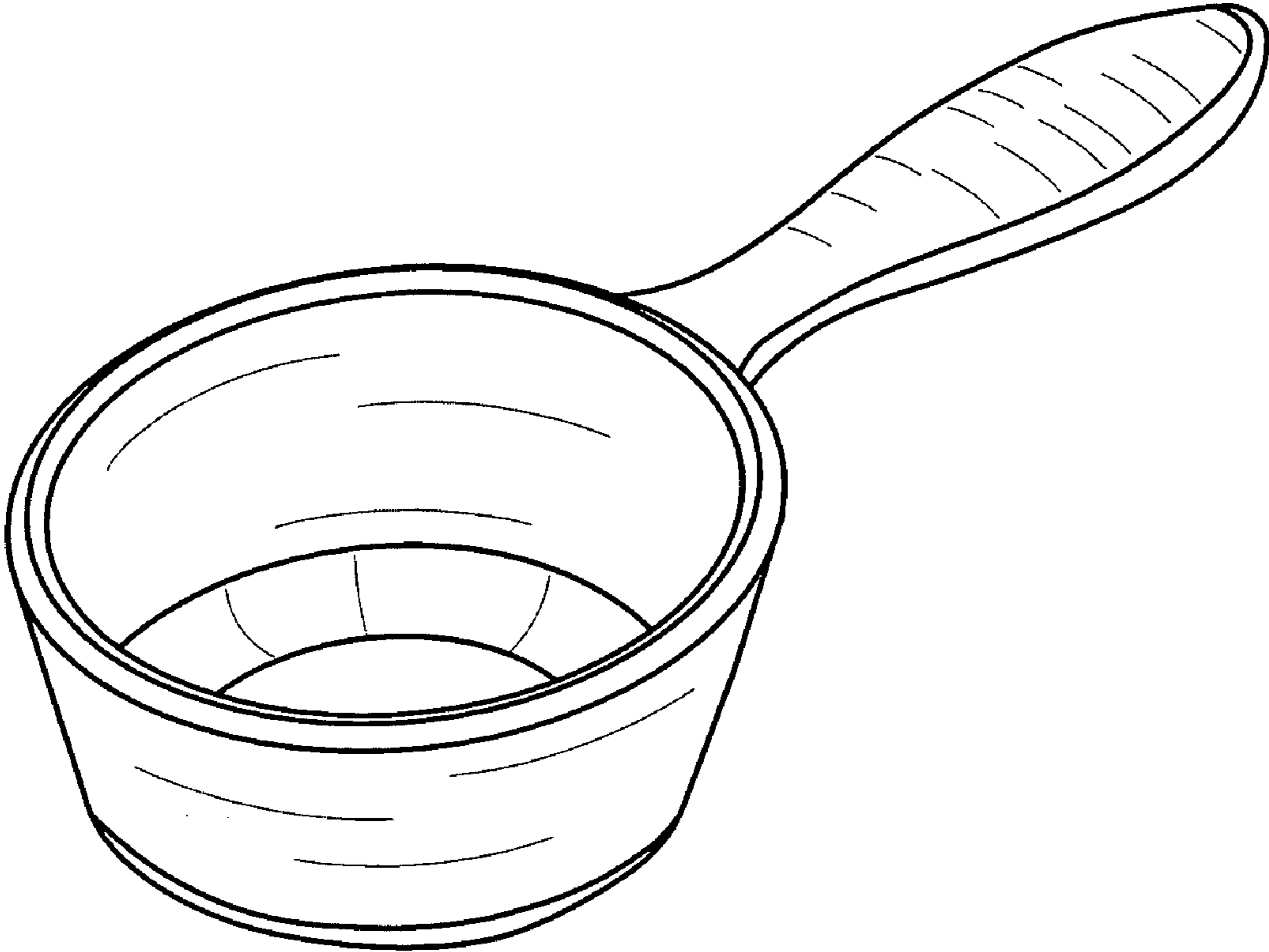

FIG. 15

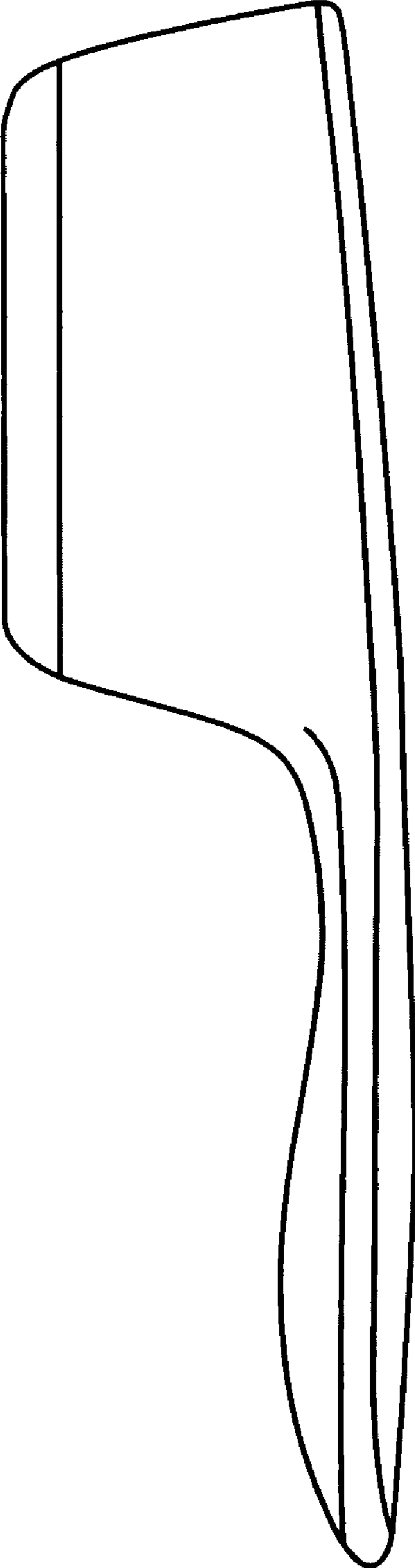

FIG. 16

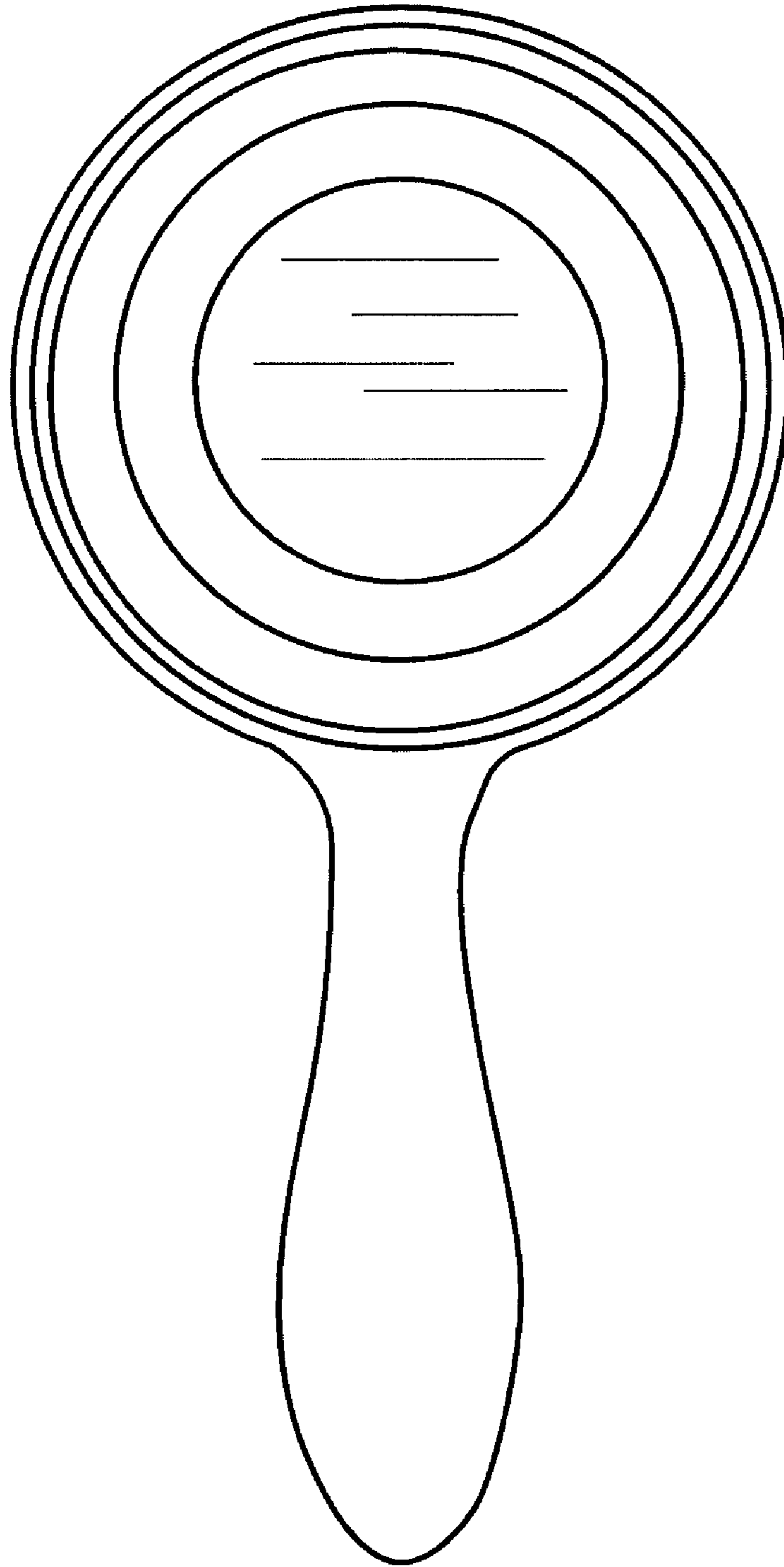

FIG. 17

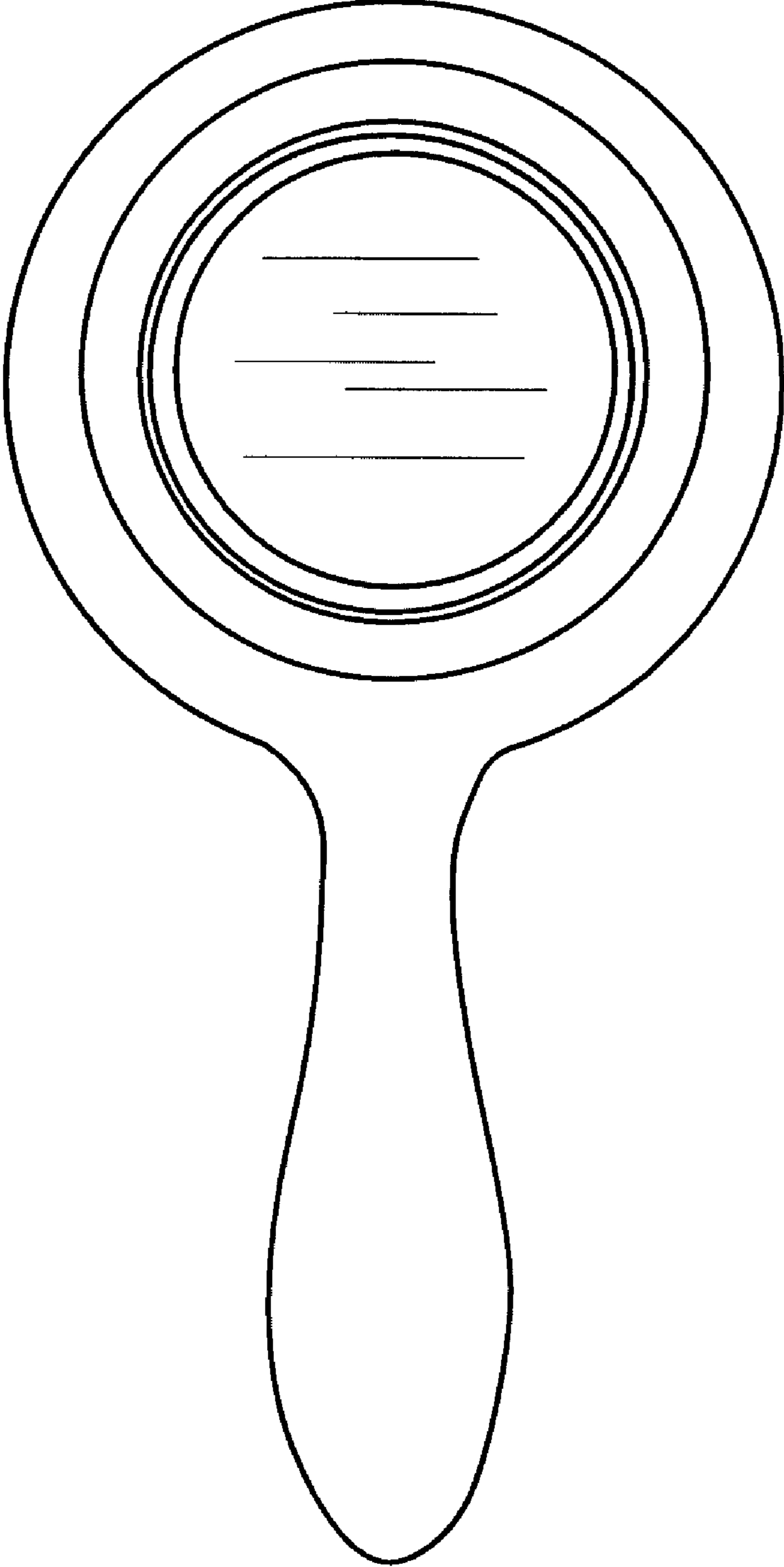

FIG. 18

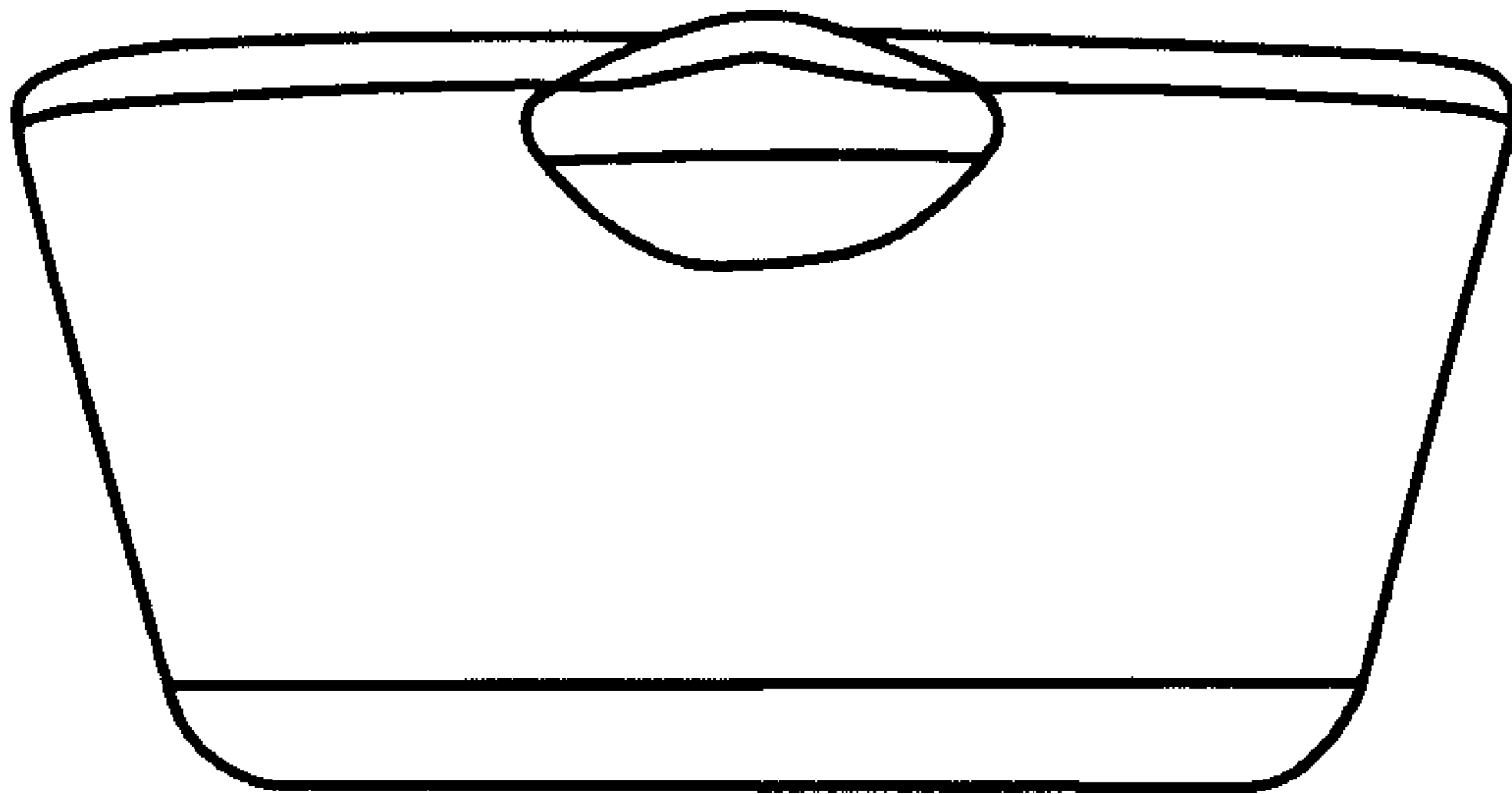

FIG. 19

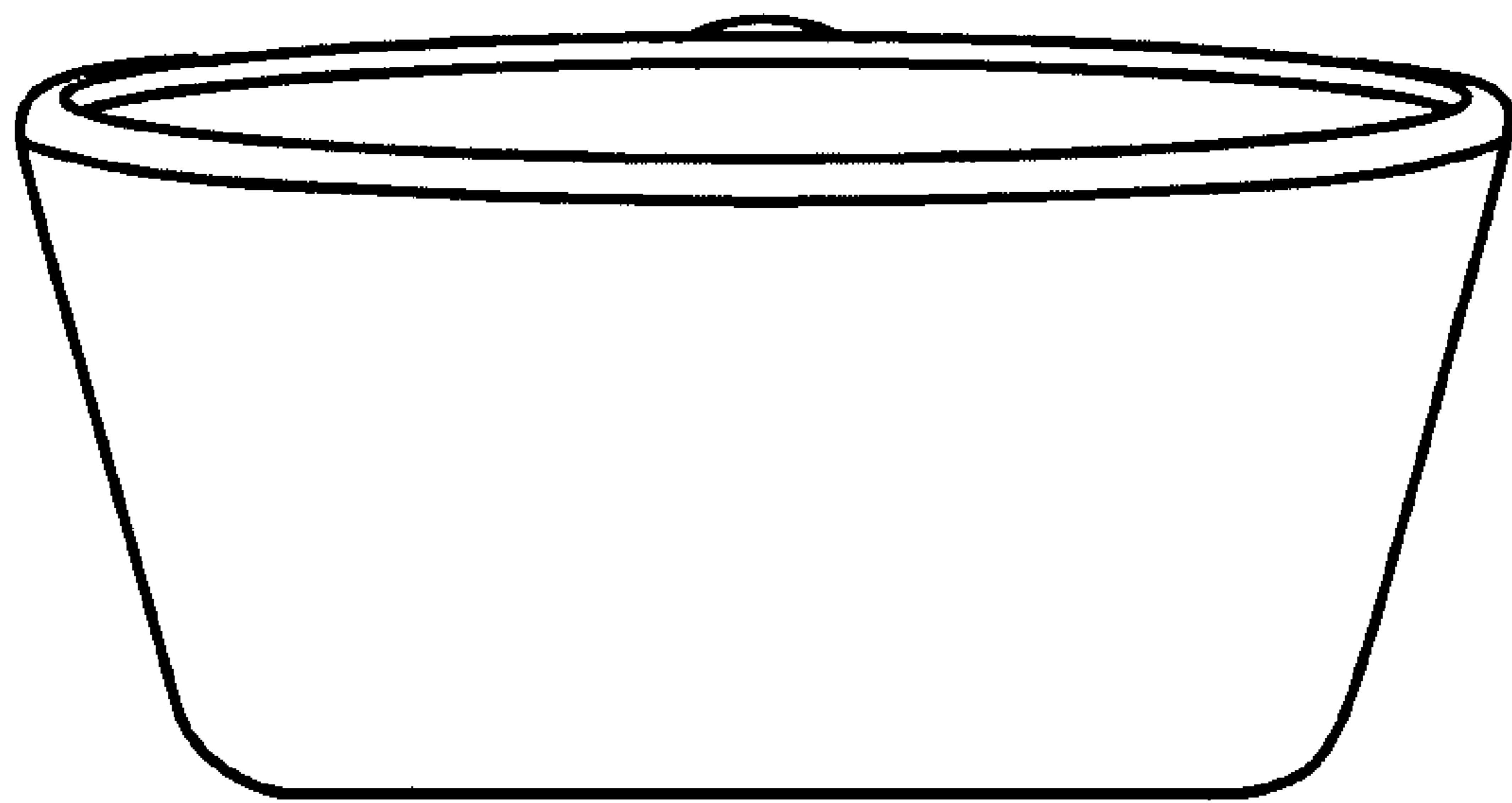

FIG. 20

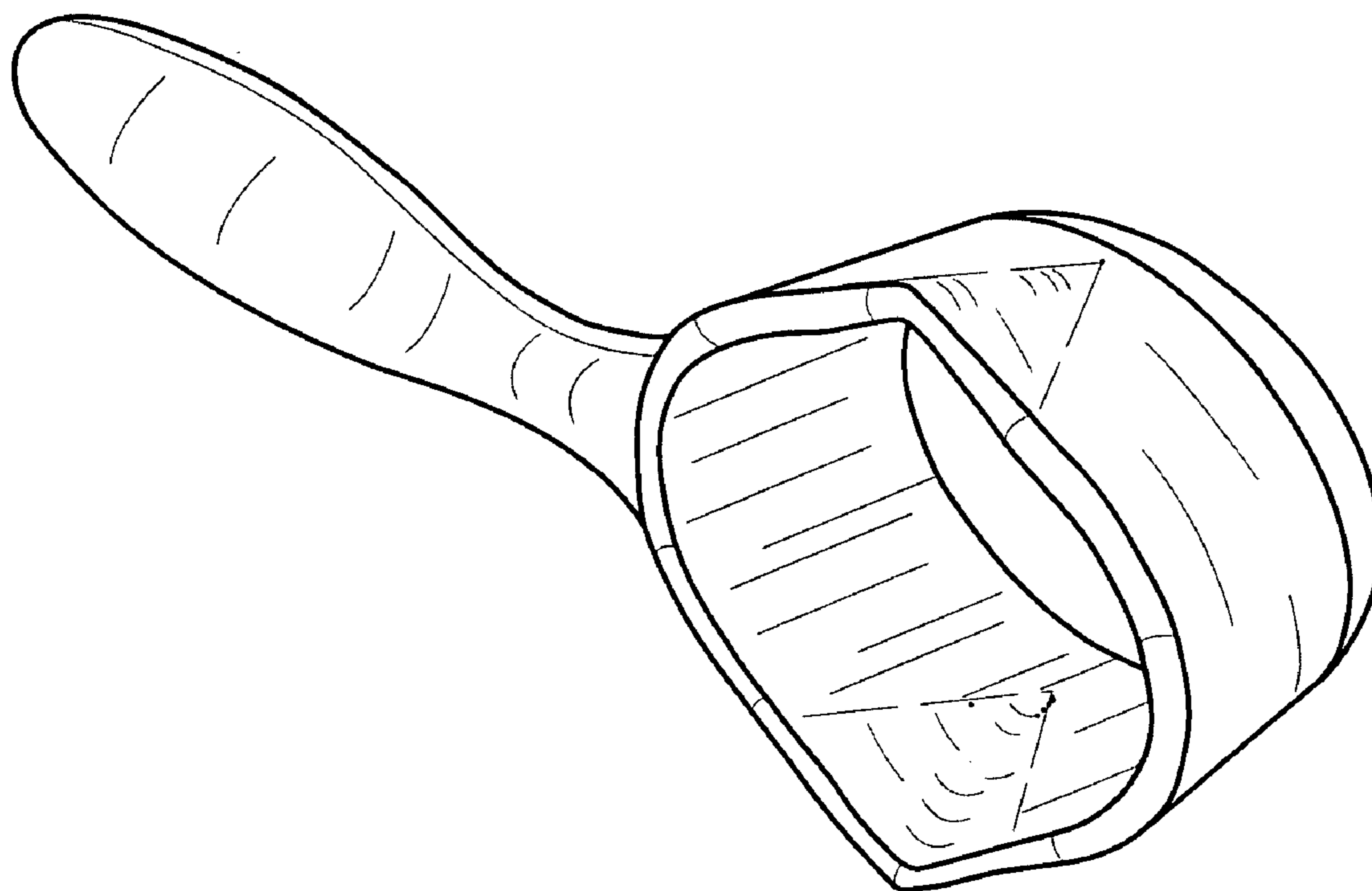

FIG. 21

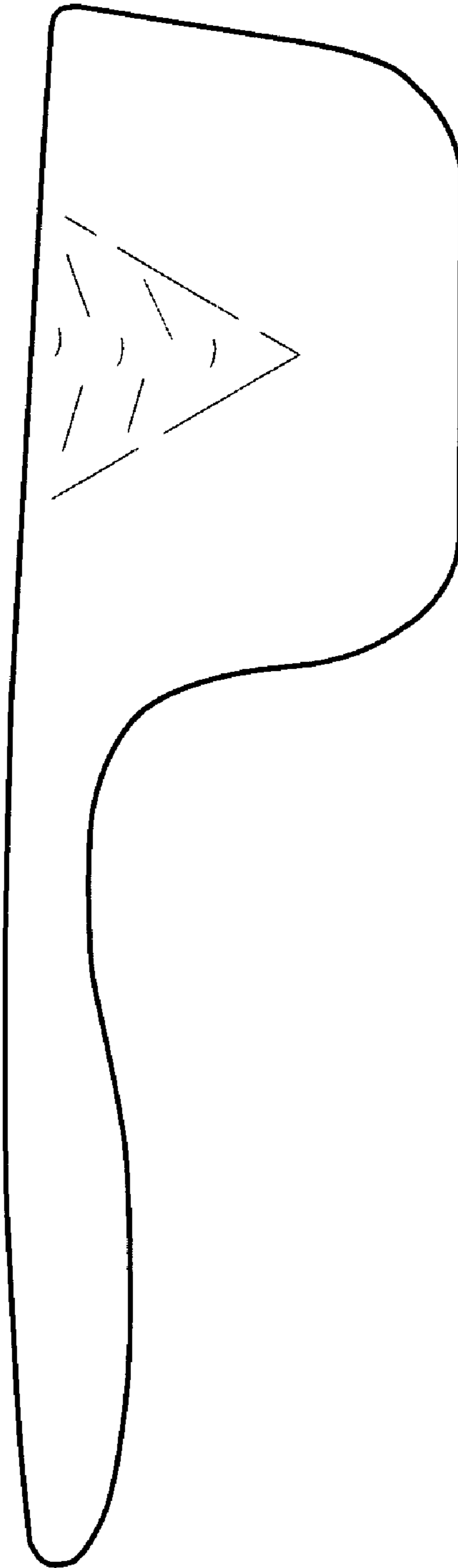

FIG. 22

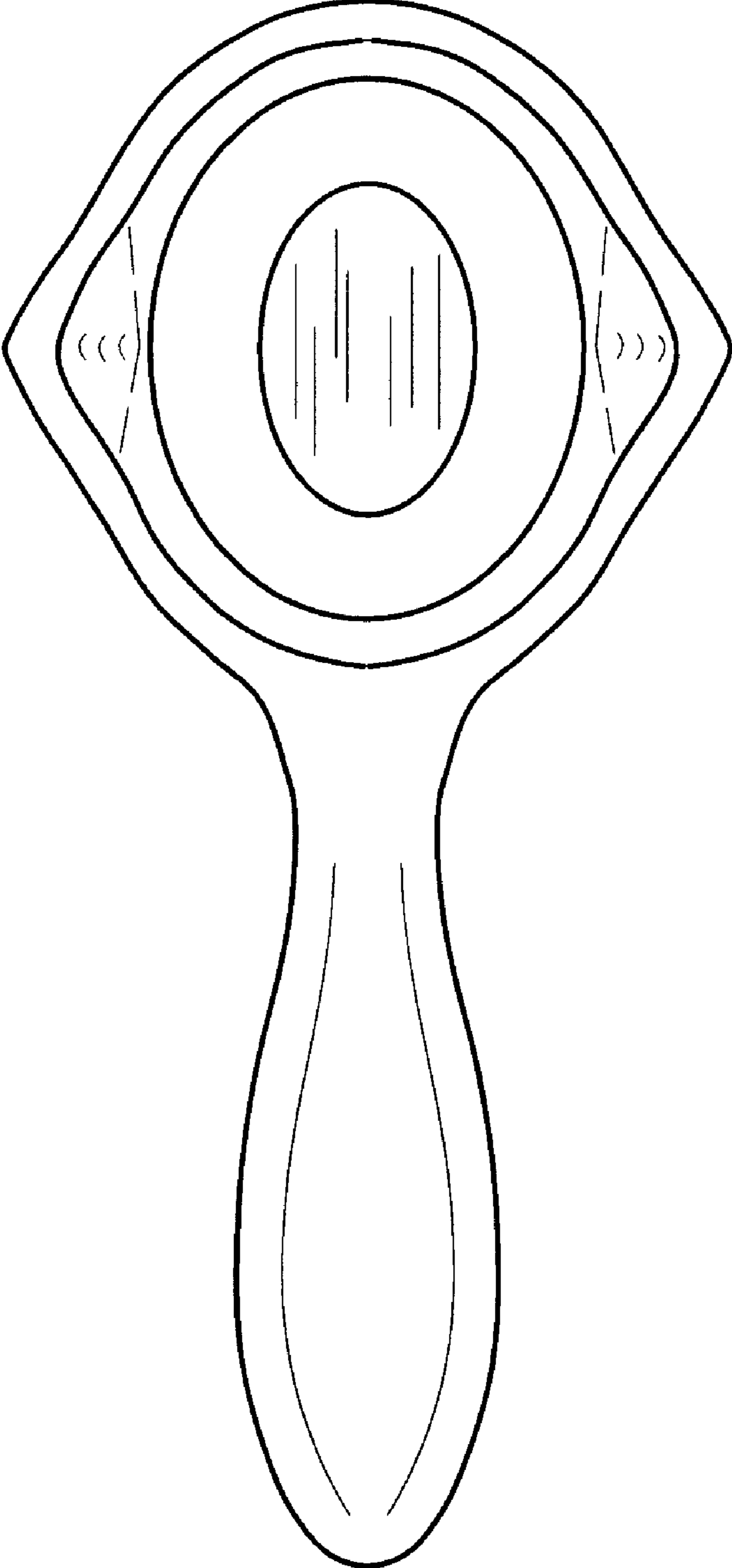

FIG. 23

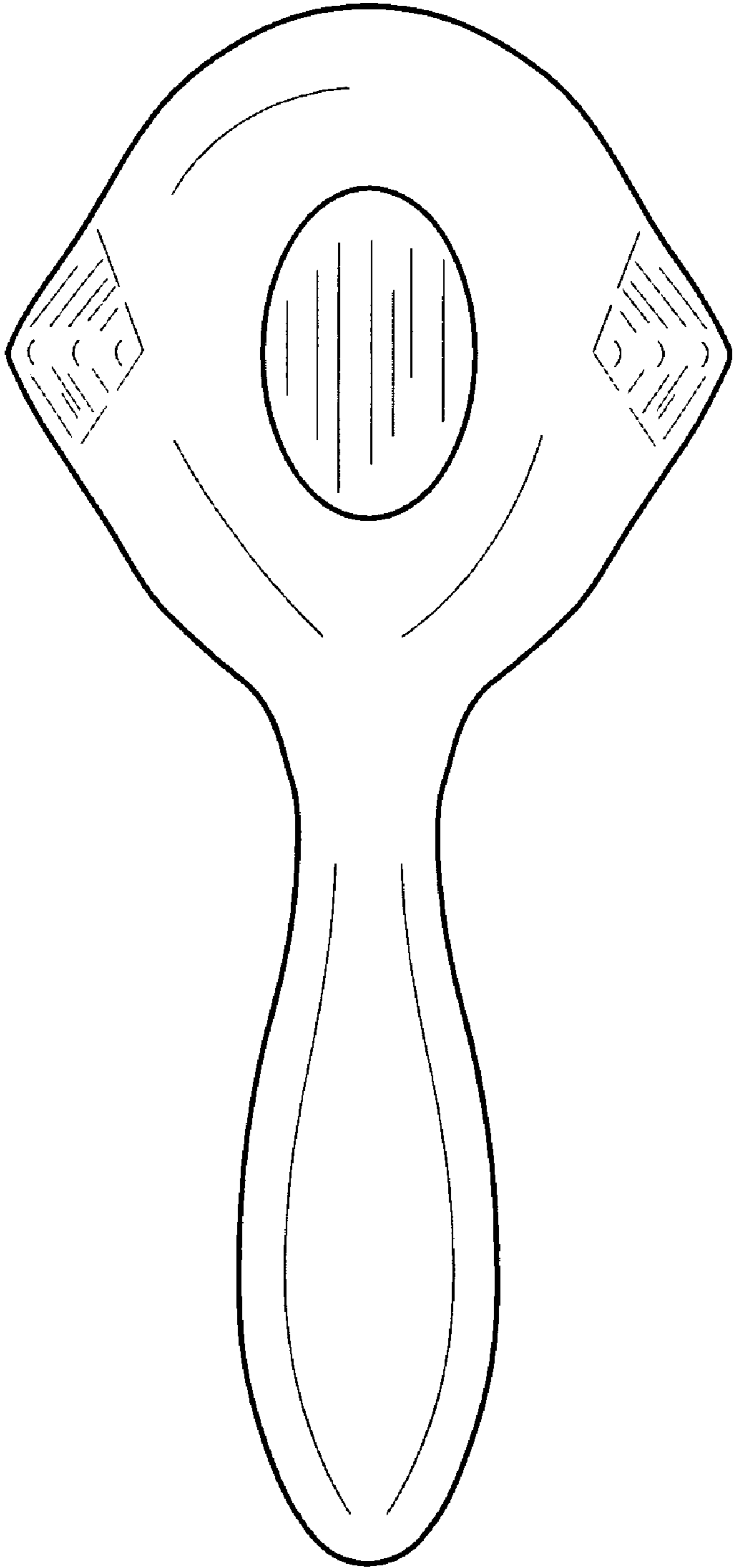

FIG. 24

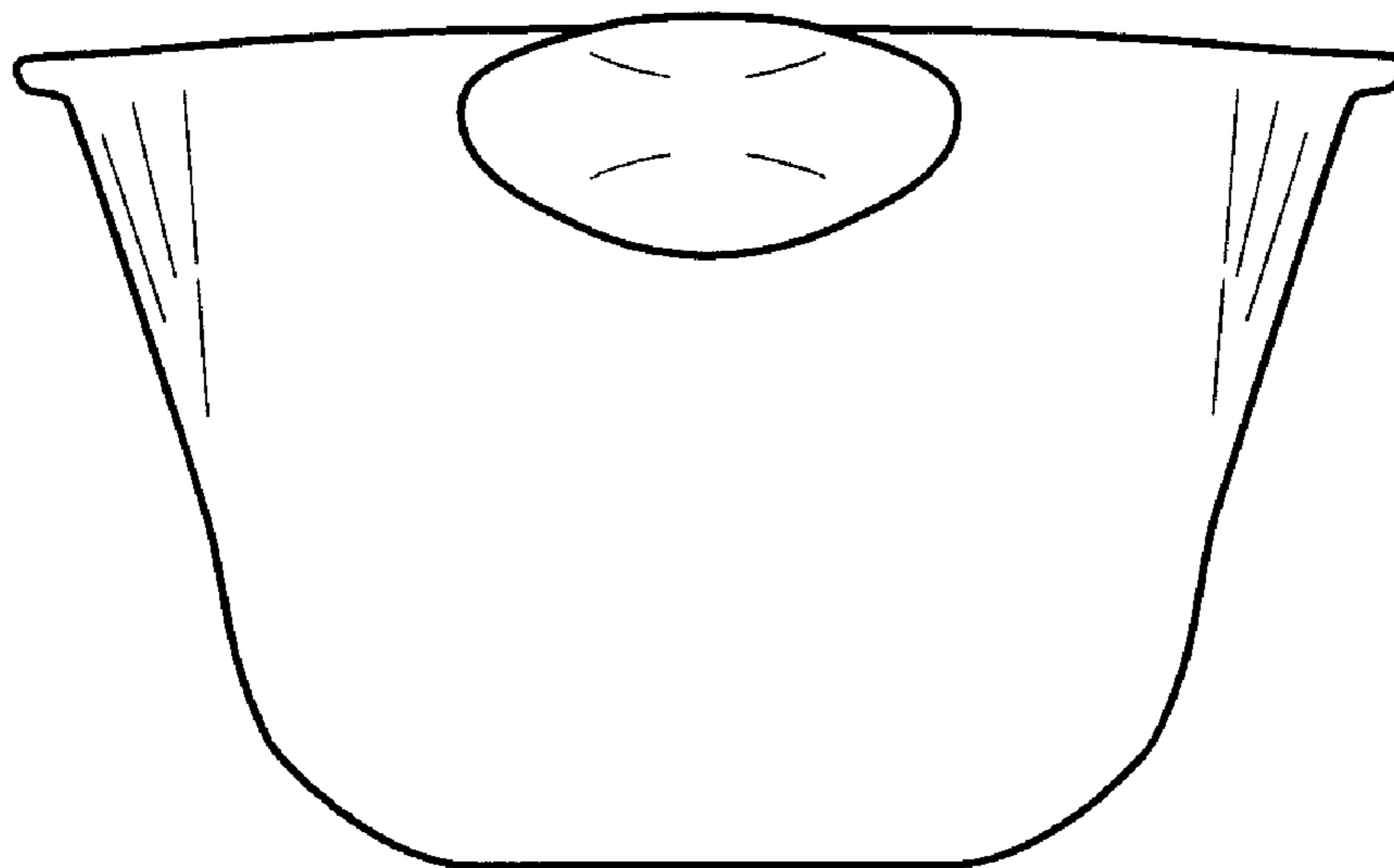

FIG. 25

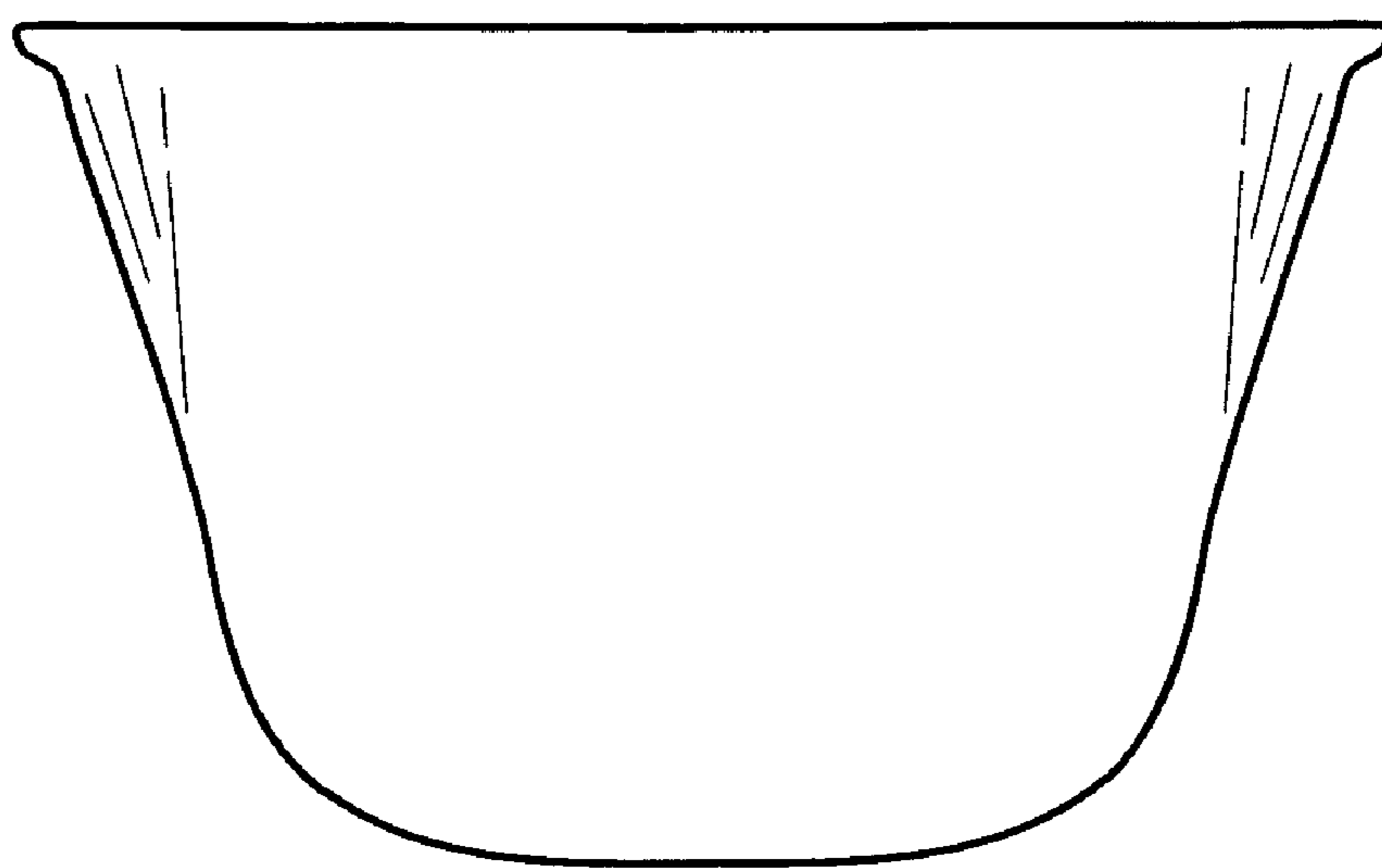

FIG. 26

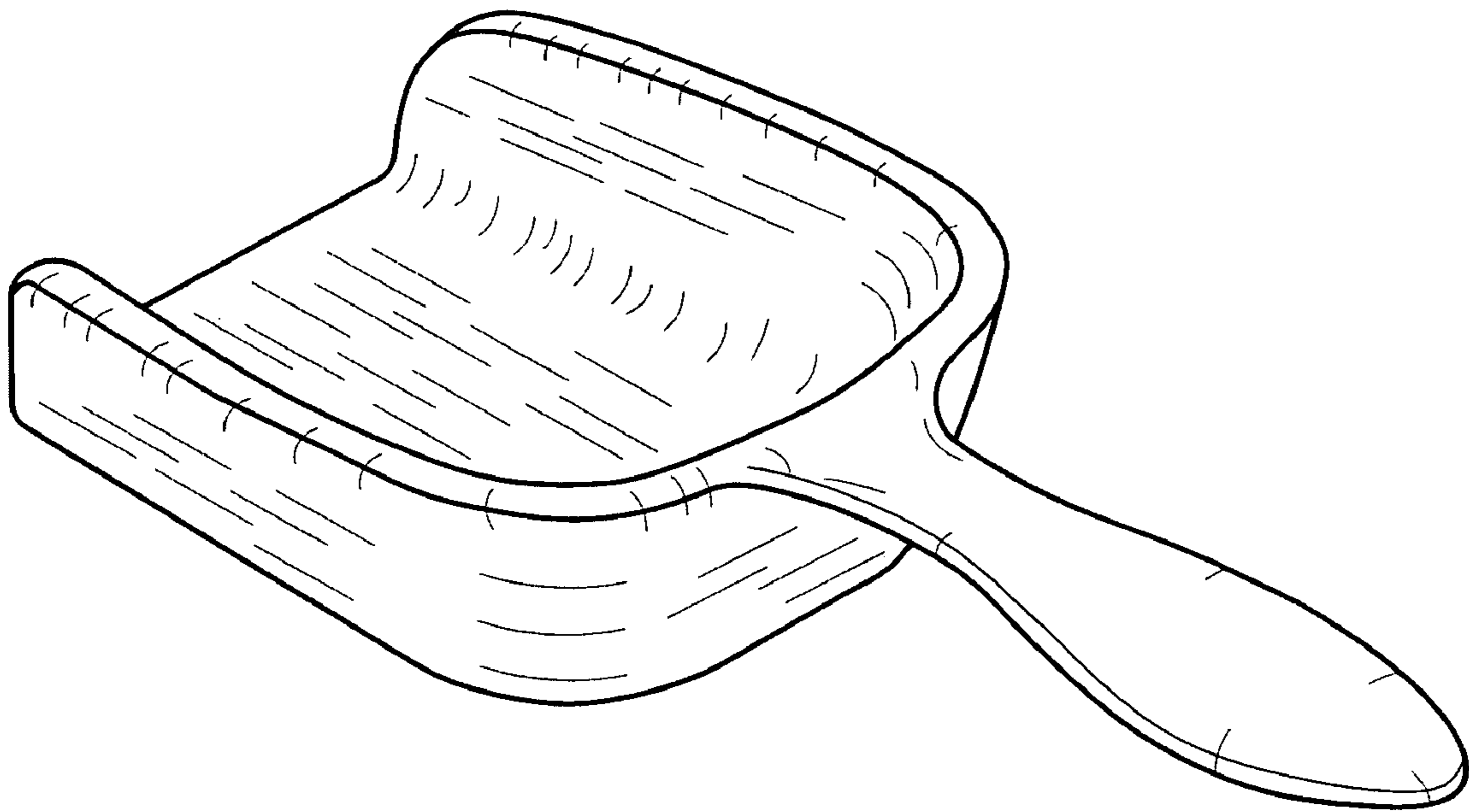

FIG. 27

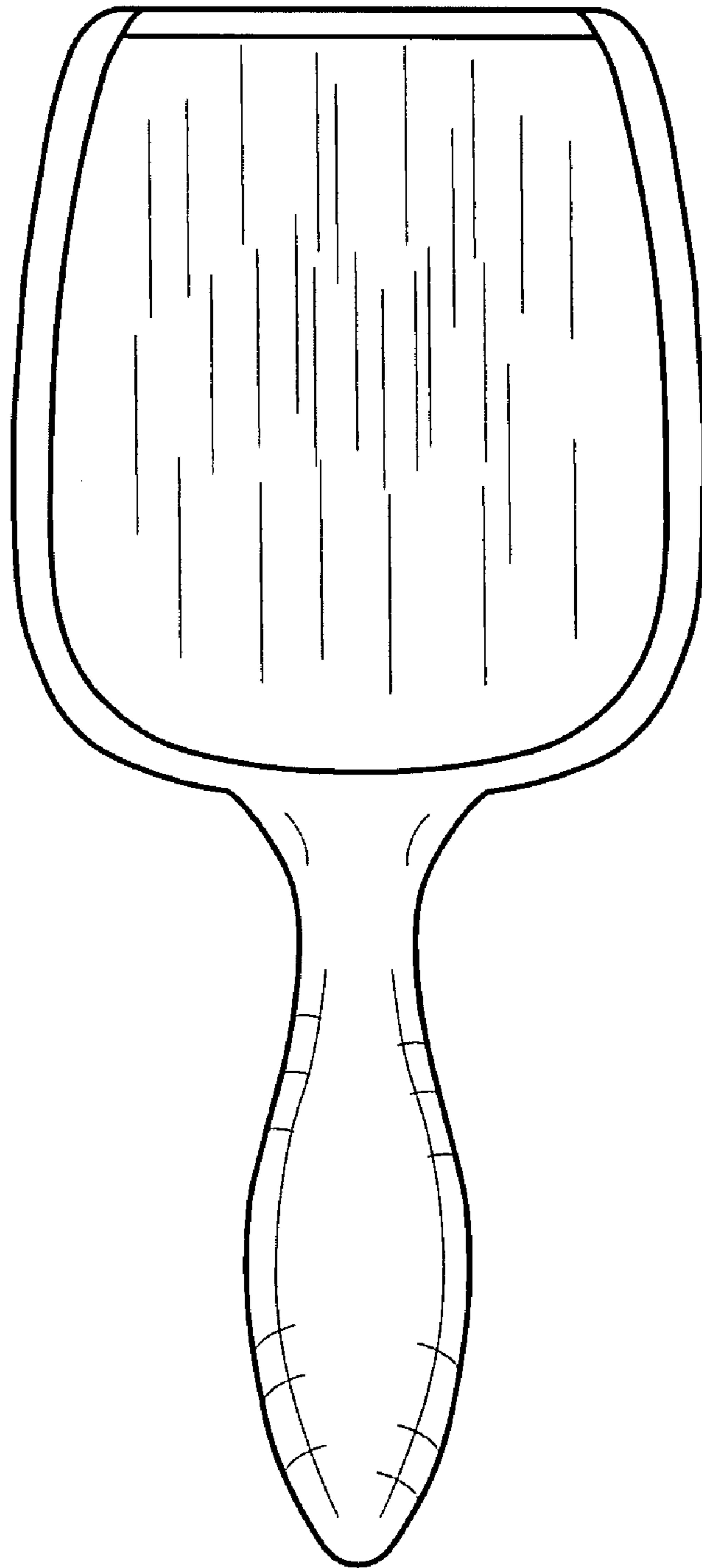

FIG. 28

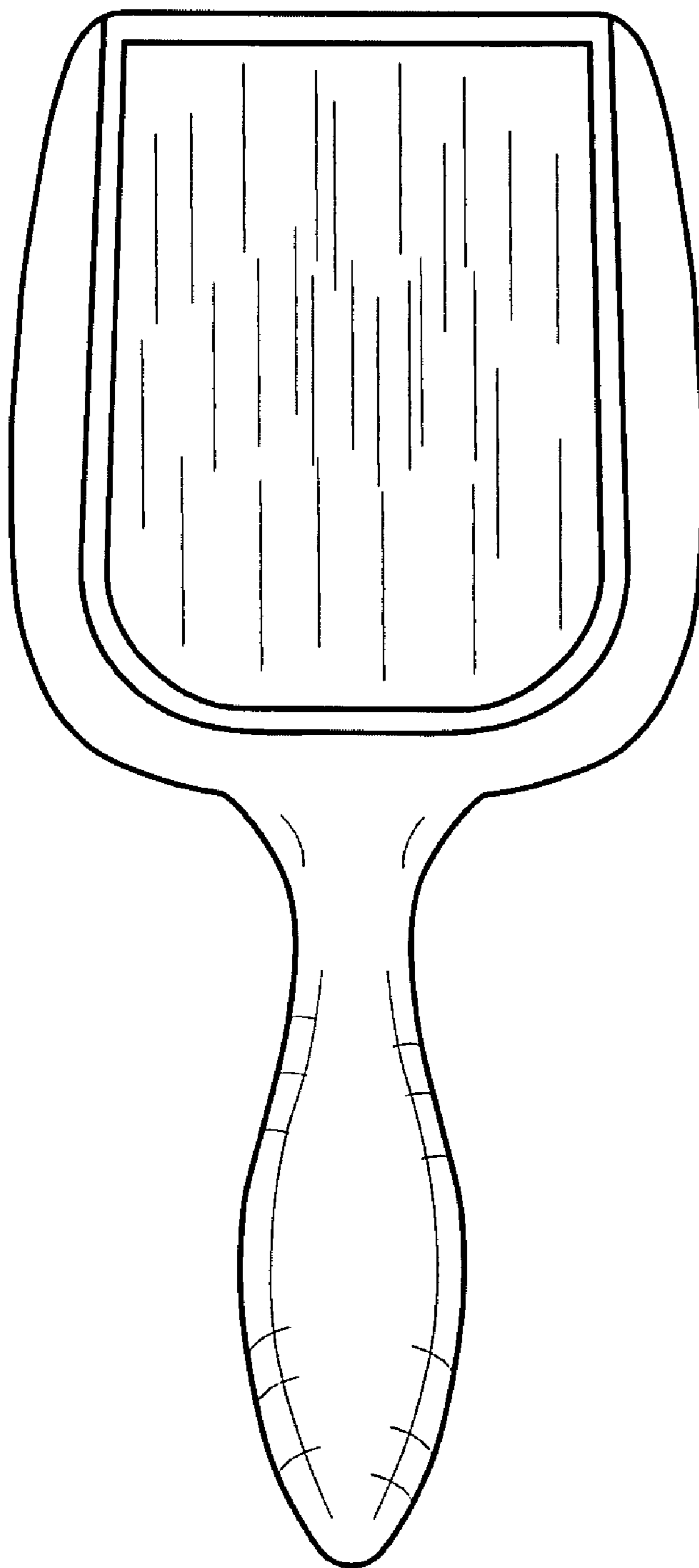

FIG. 29

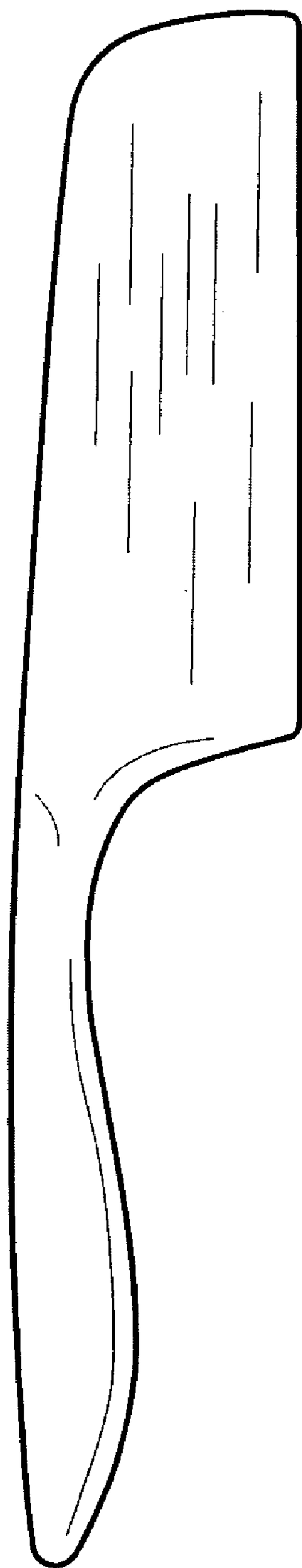

FIG. 30

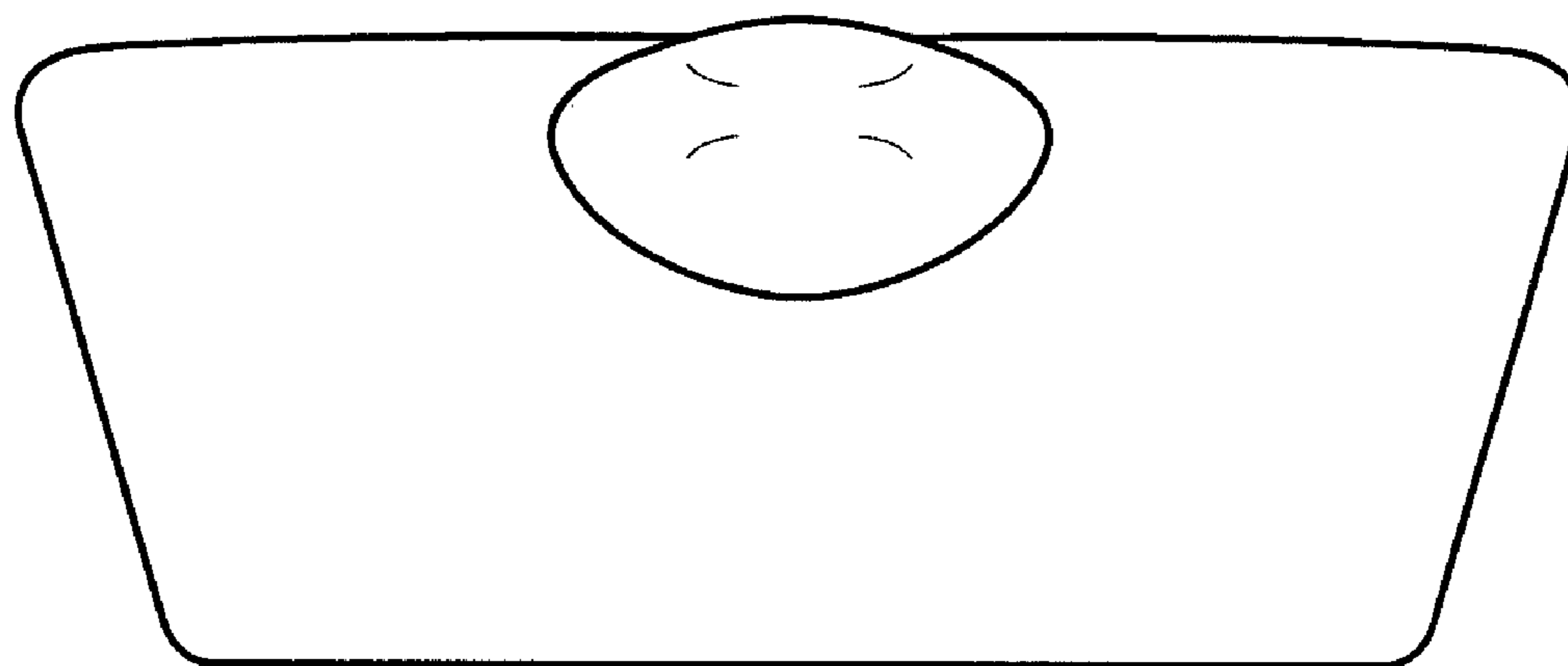

FIG. 31

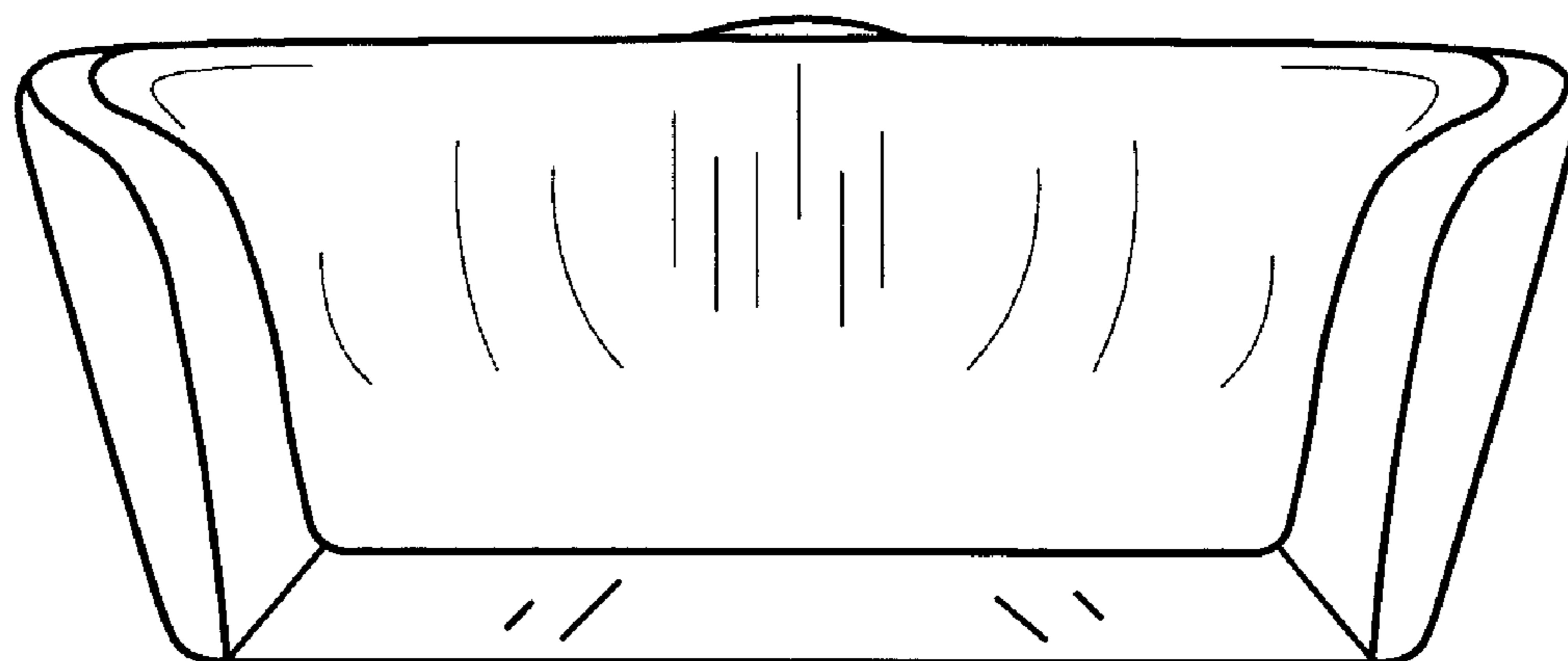

FIG. 32

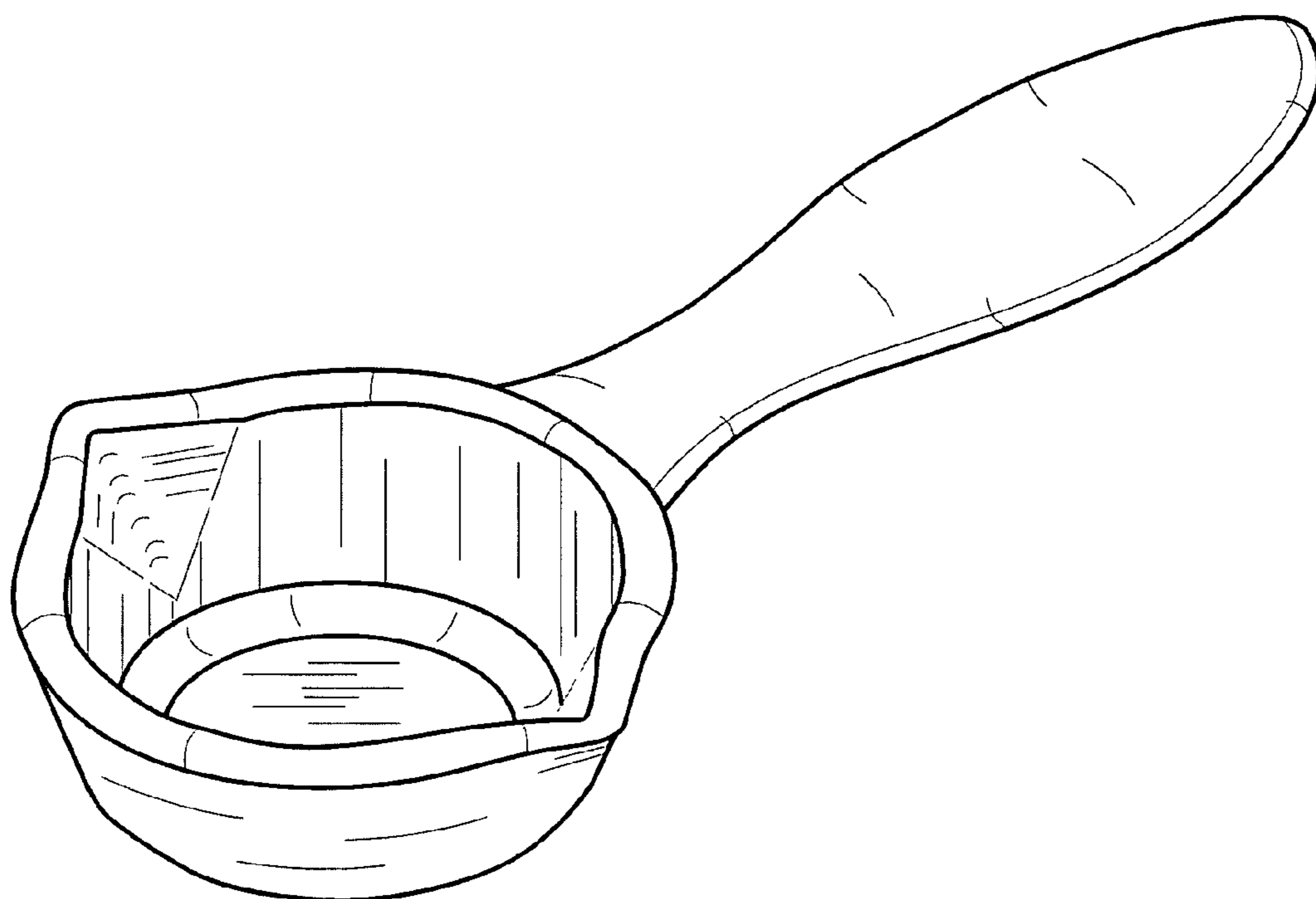

FIG. 33

Title: Portion control measuring devices and base unit
Inventors: Kevin D. Johnson et al.
Attorney Docket No. 190891/US

32 / 50

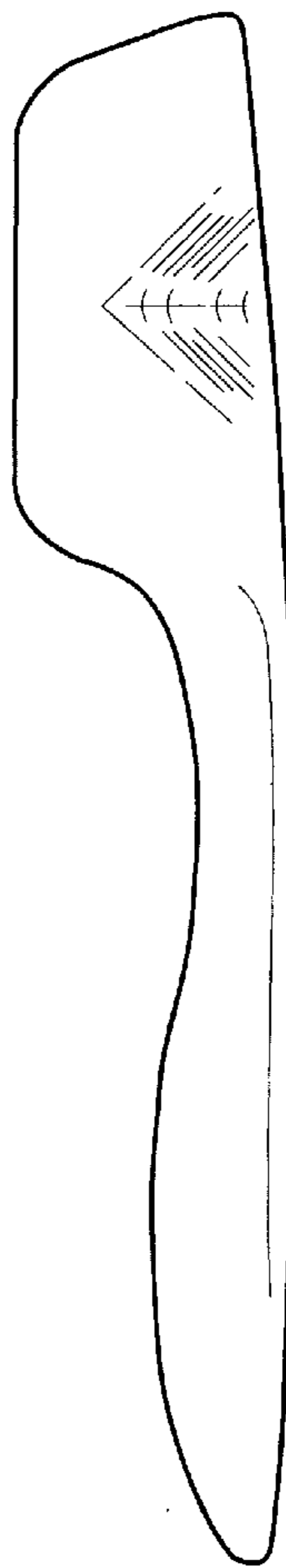

FIG. 34

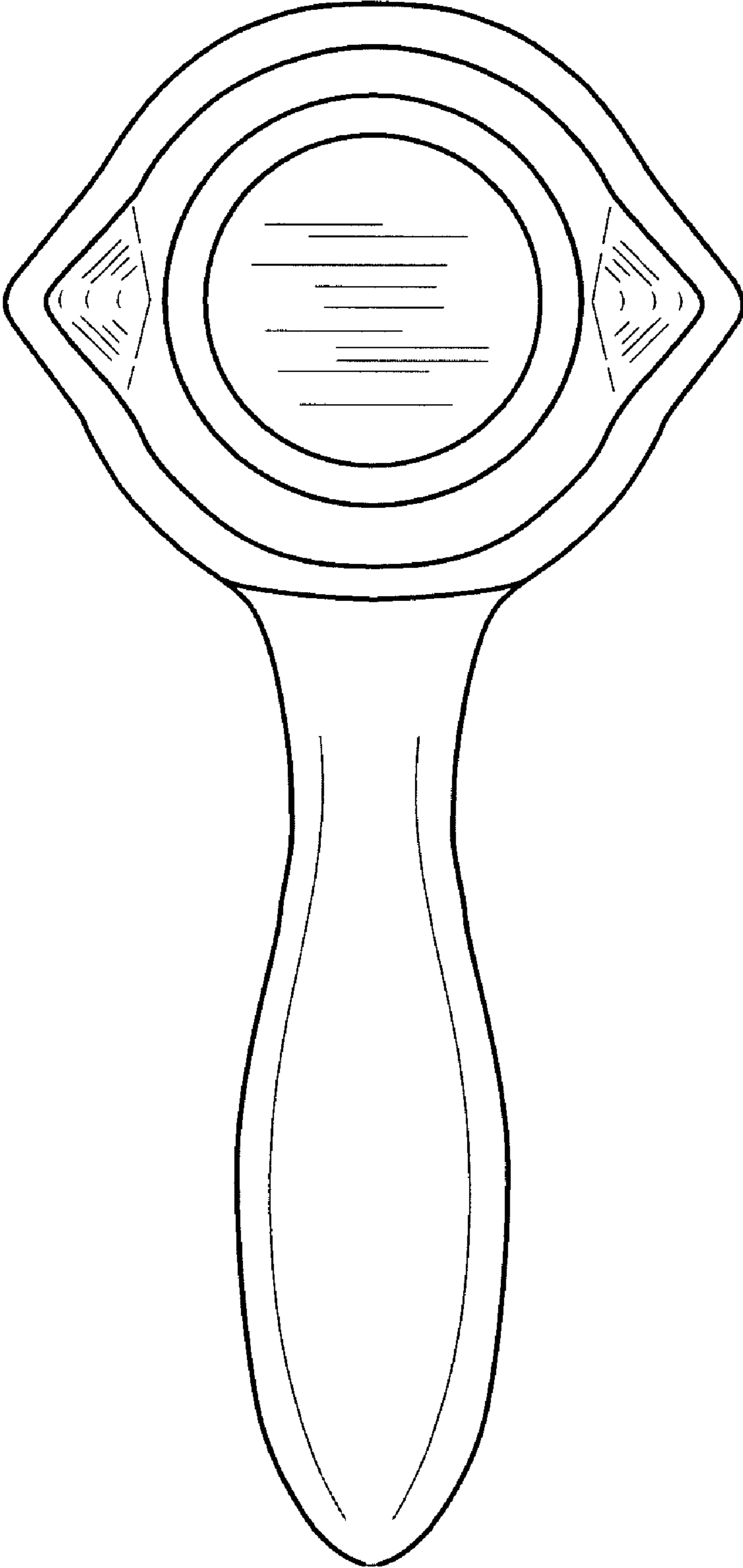

FIG. 35

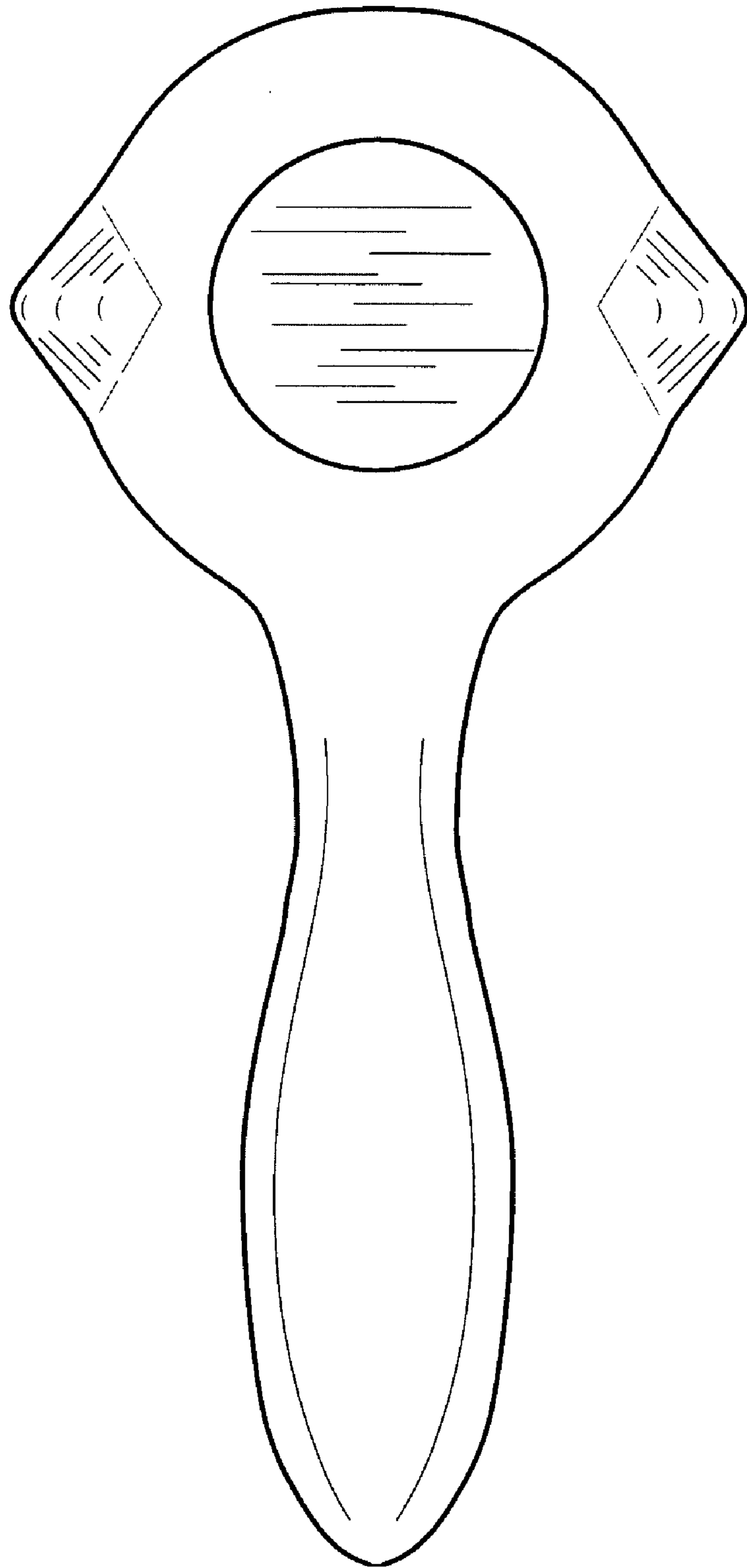

FIG. 36

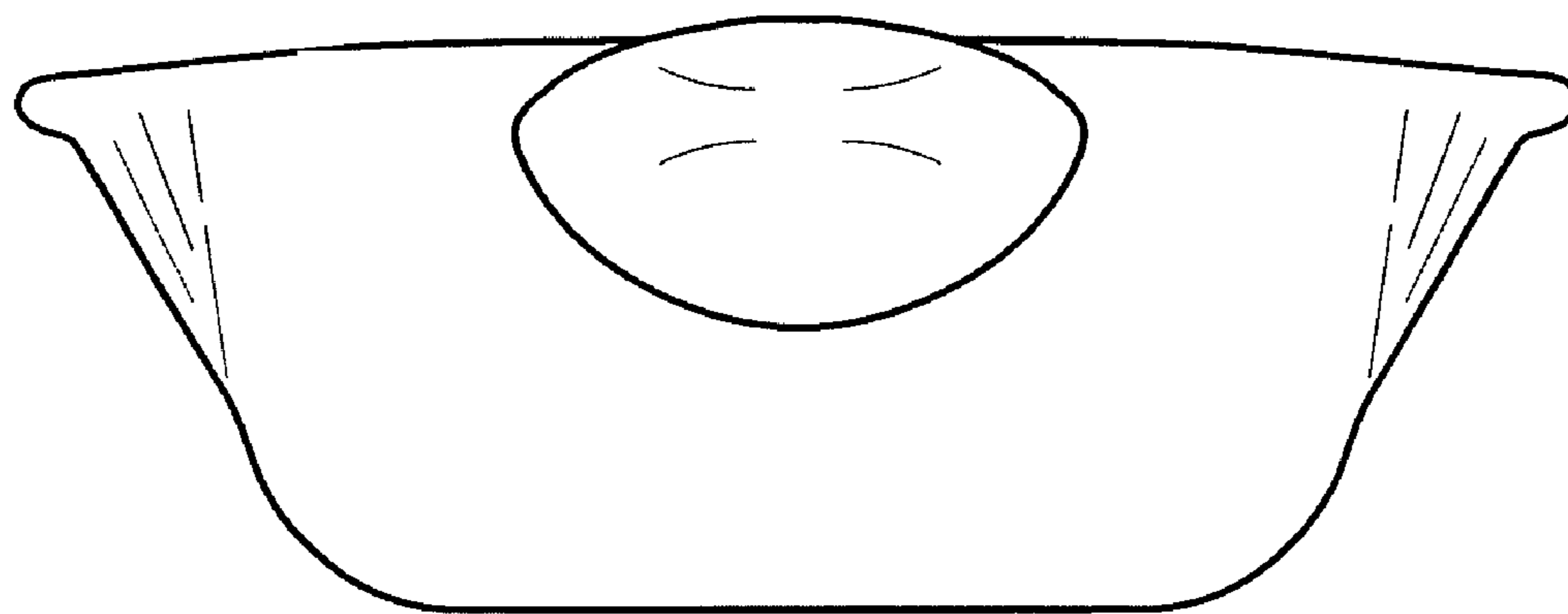

FIG. 37

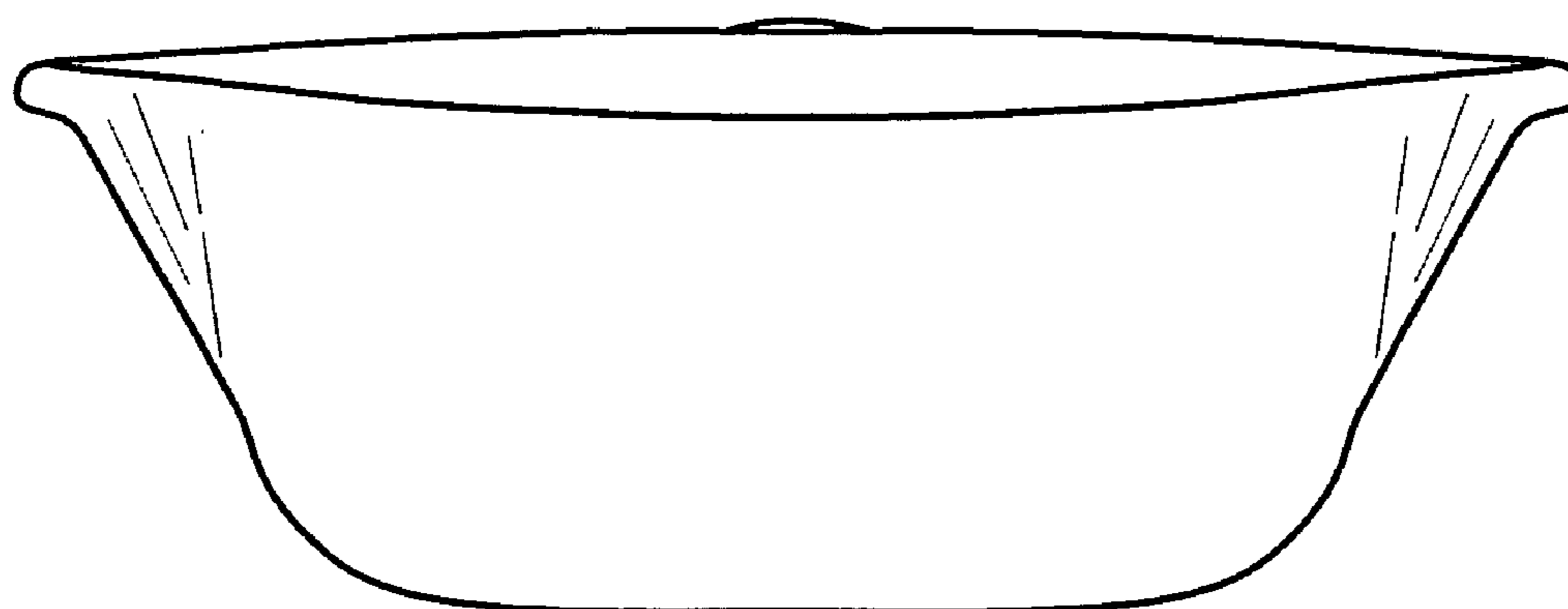

FIG. 38

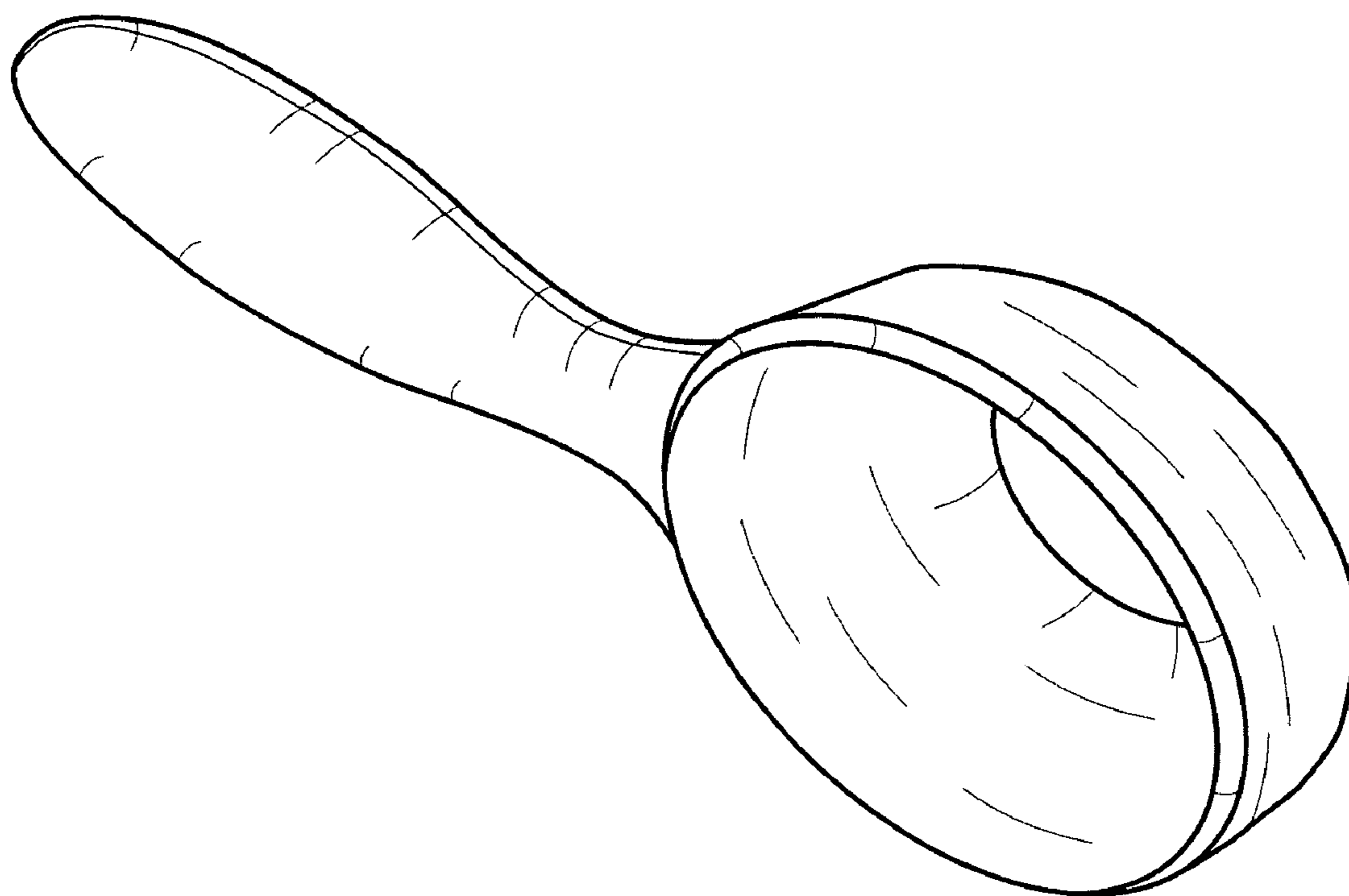

FIG. 39

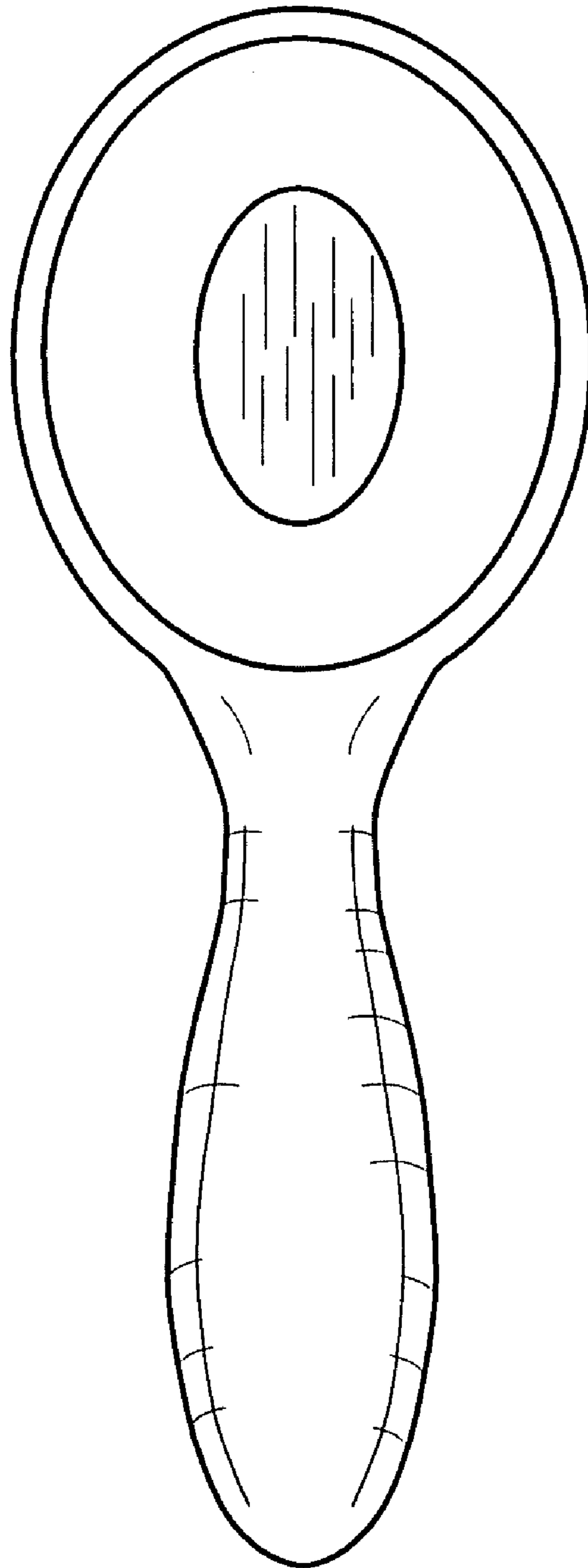

FIG. 40

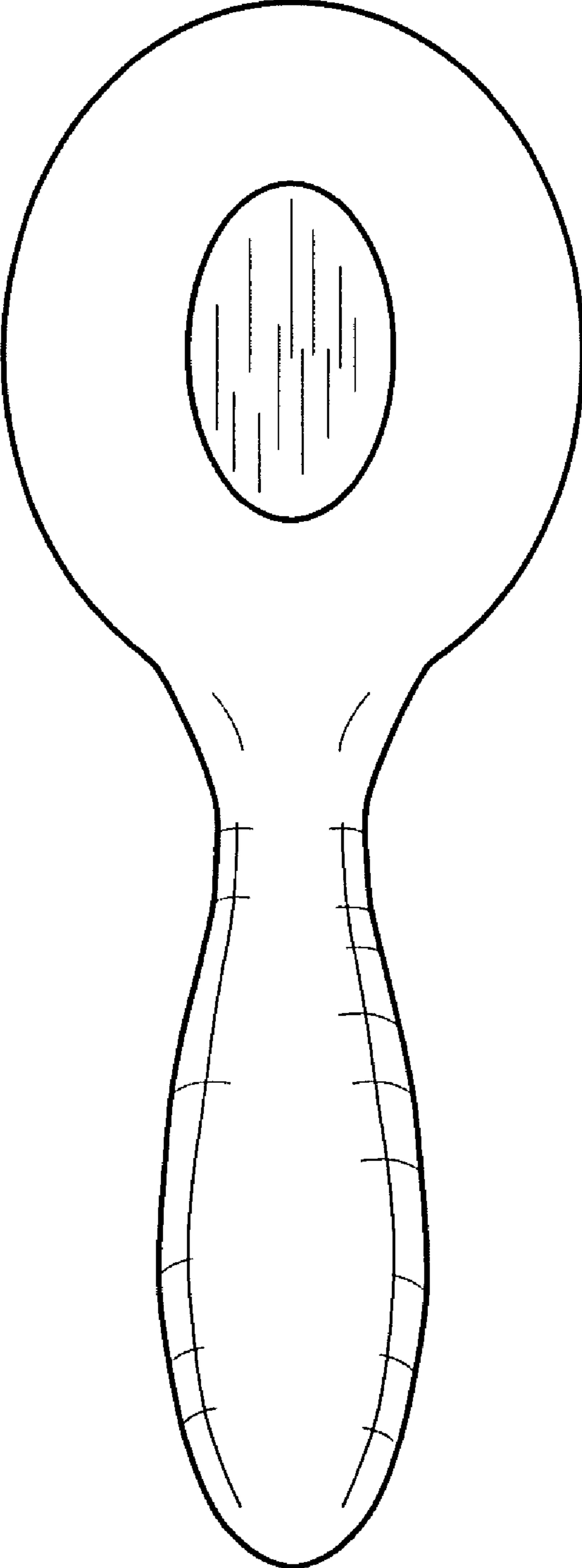

FIG. 41

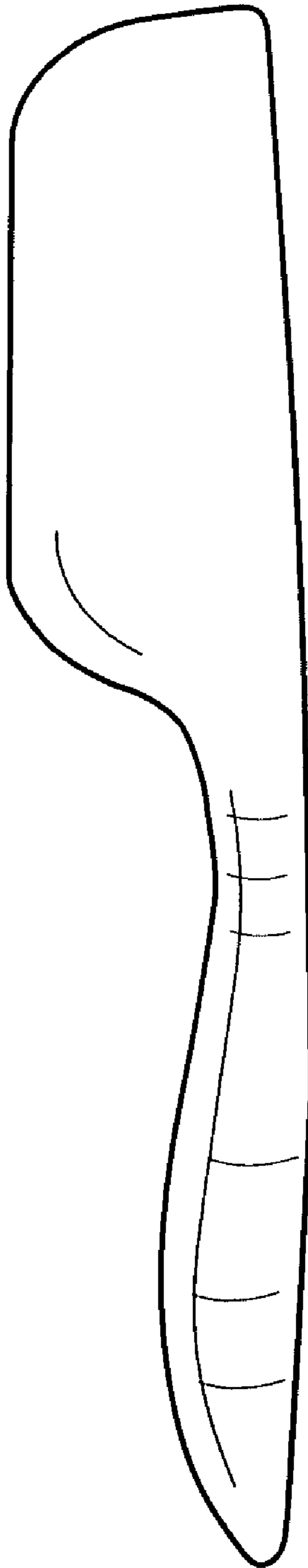

FIG. 42

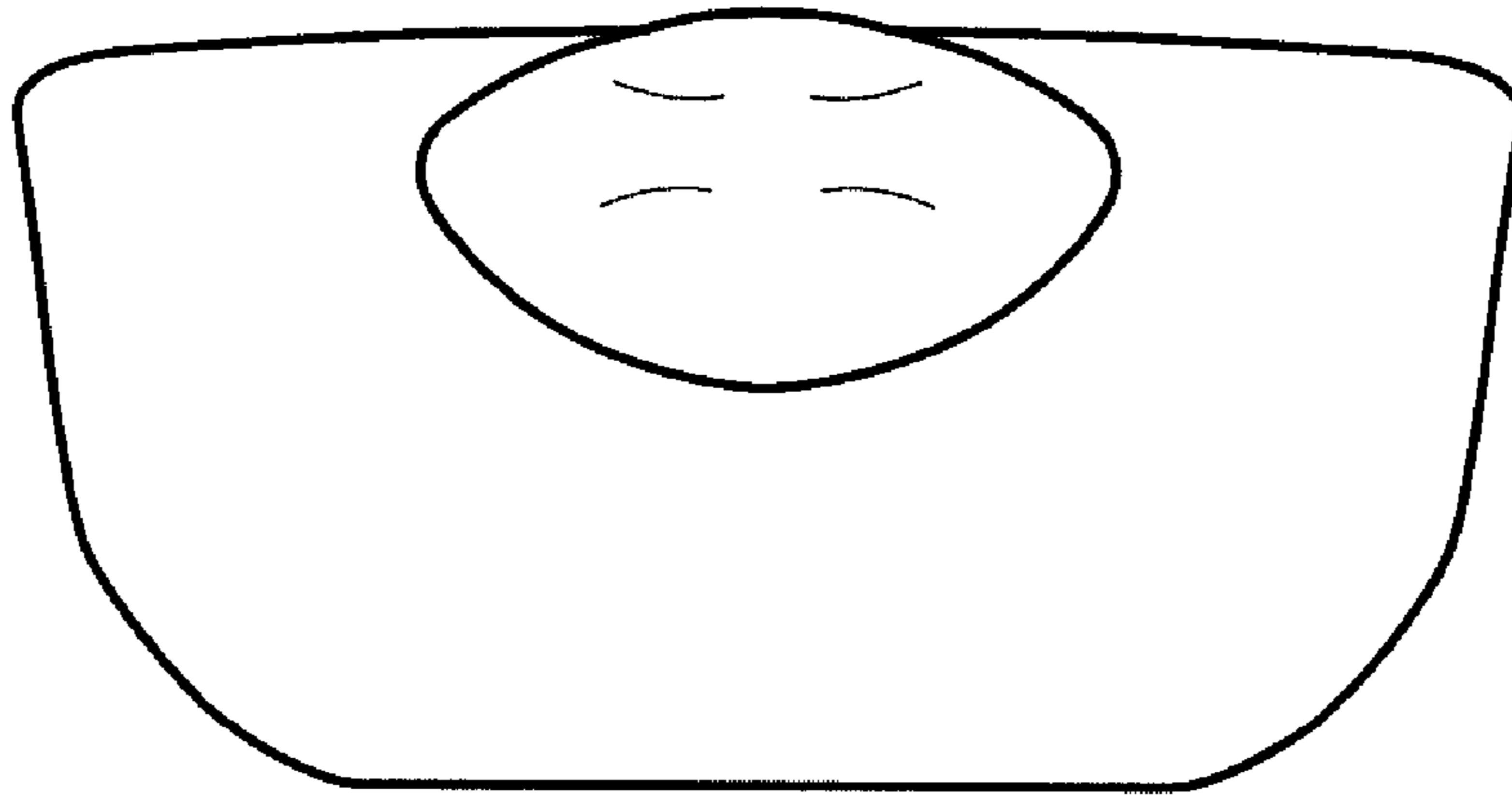

FIG. 43

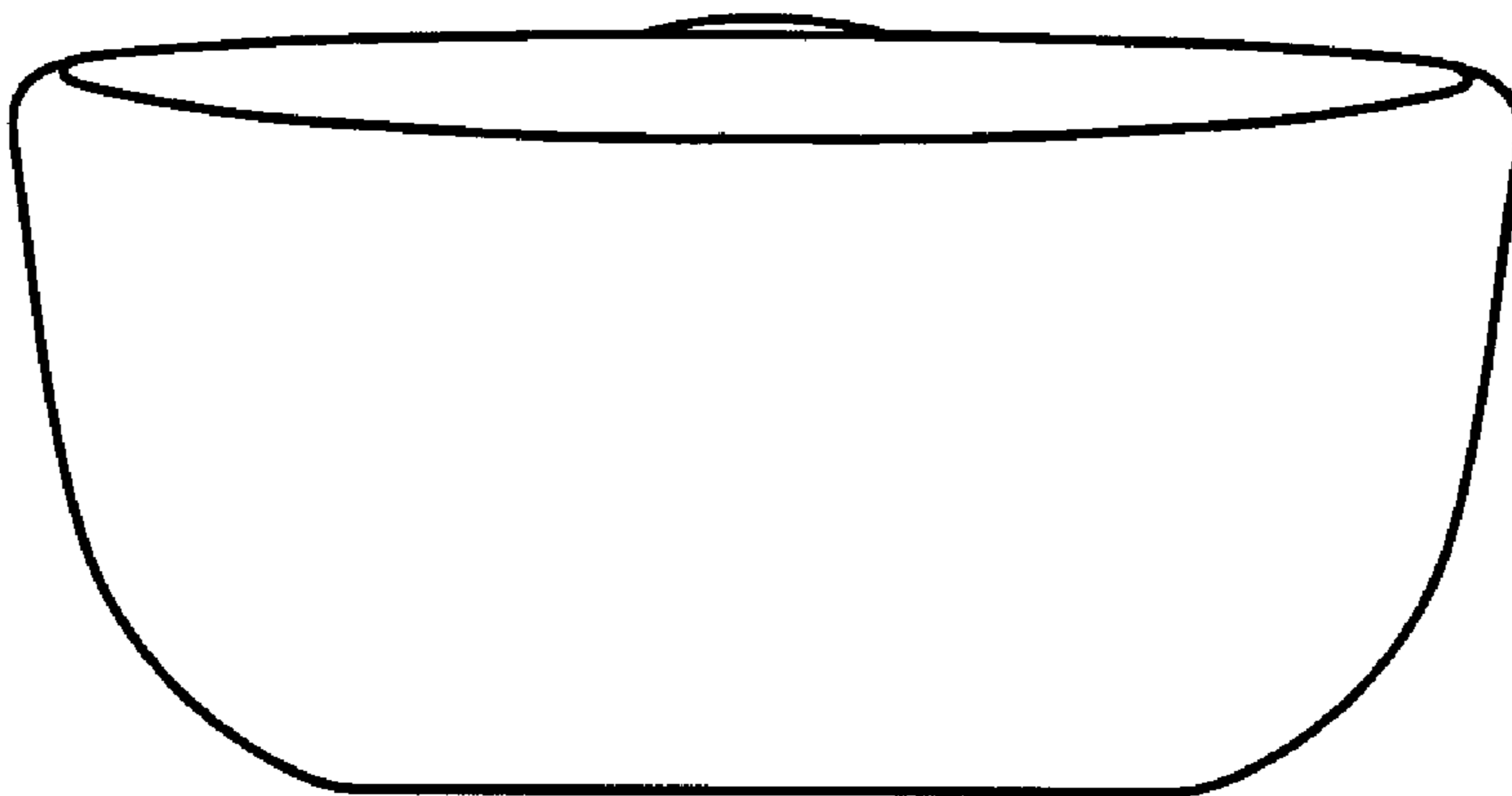

FIG. 44

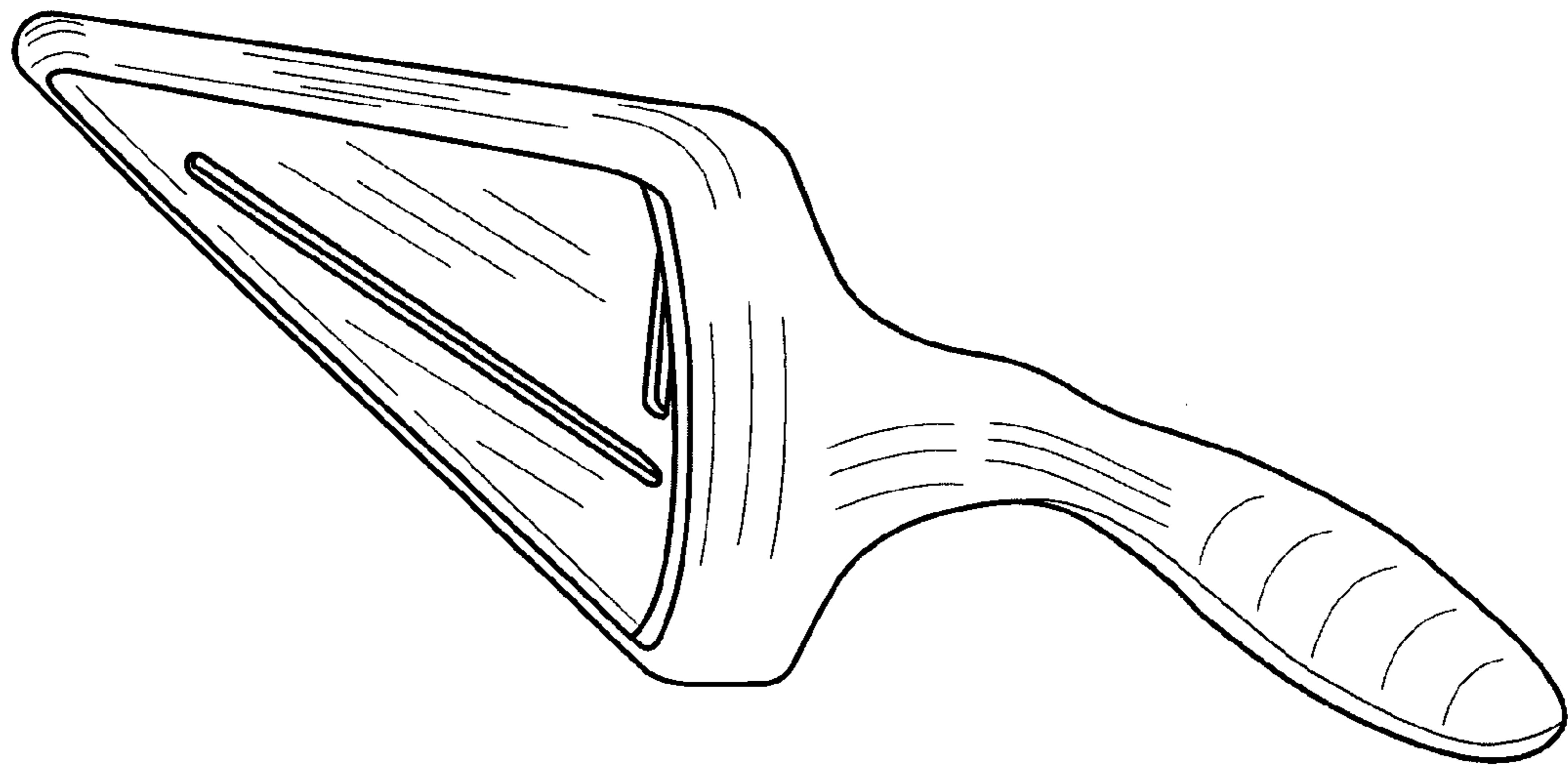

FIG. 45

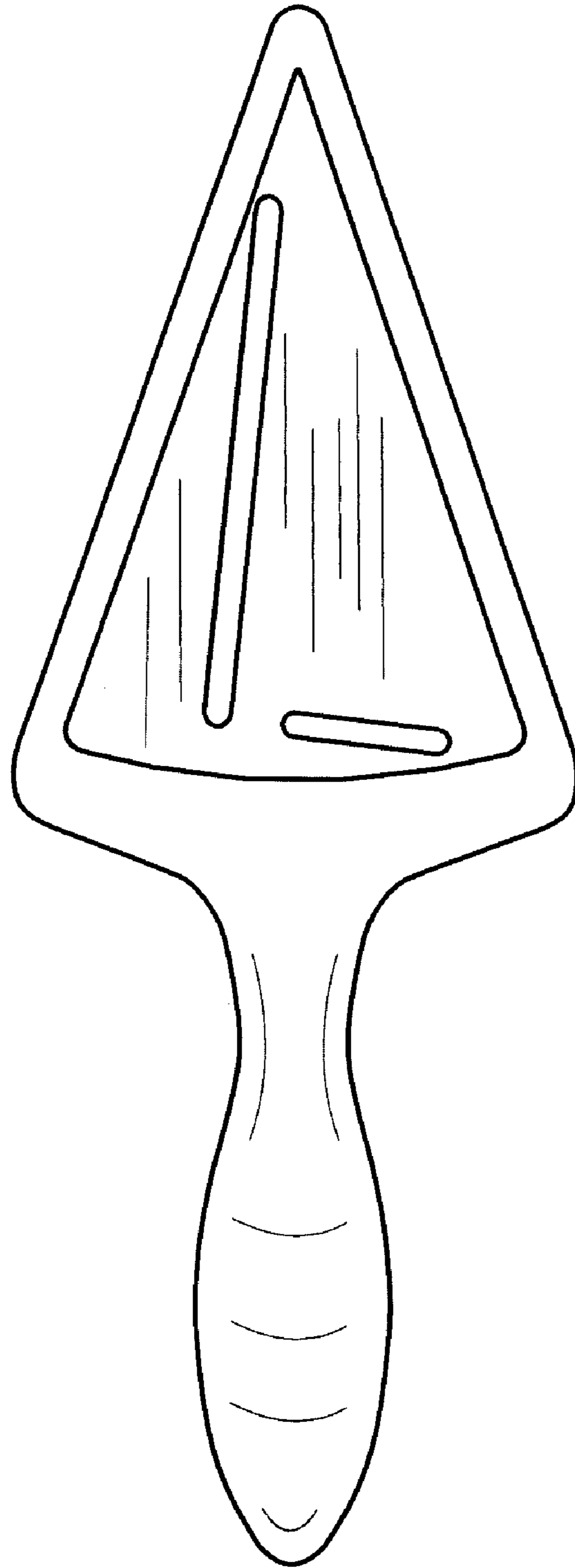

FIG. 46

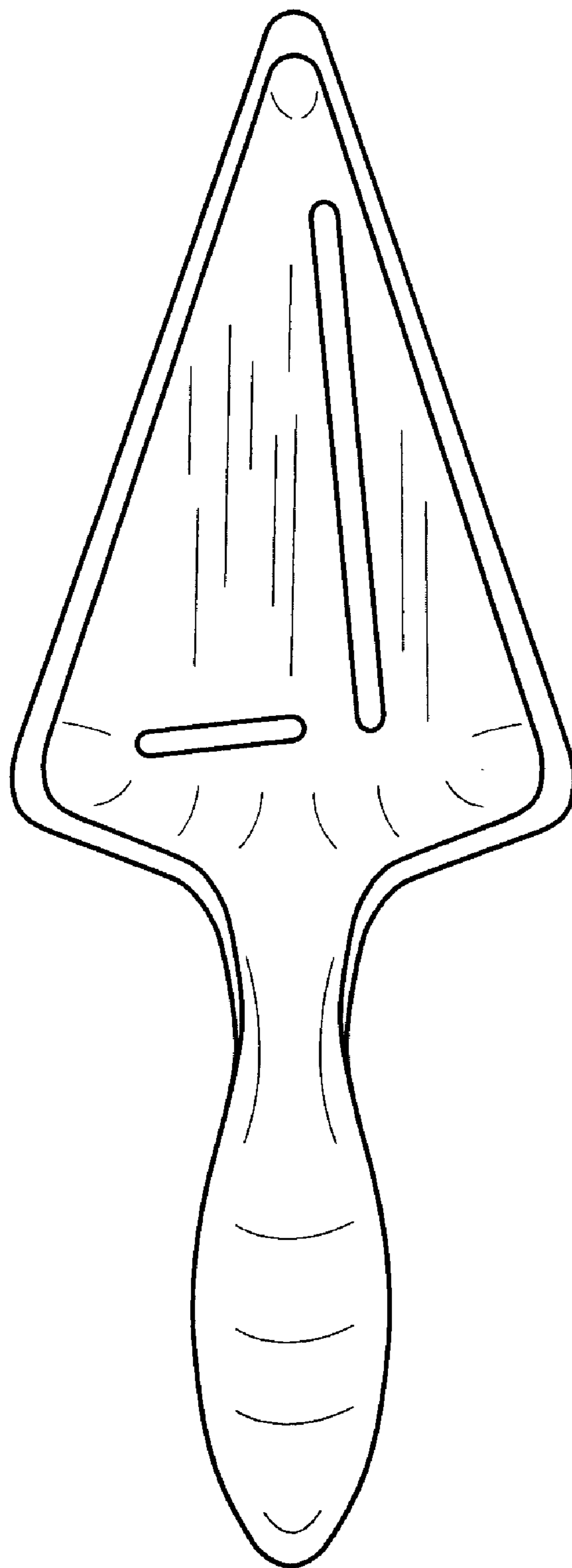

FIG. 47

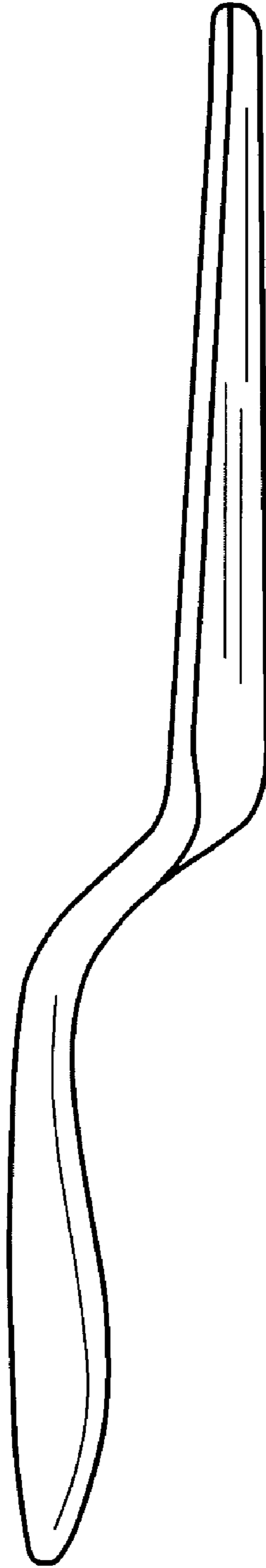

FIG. 48

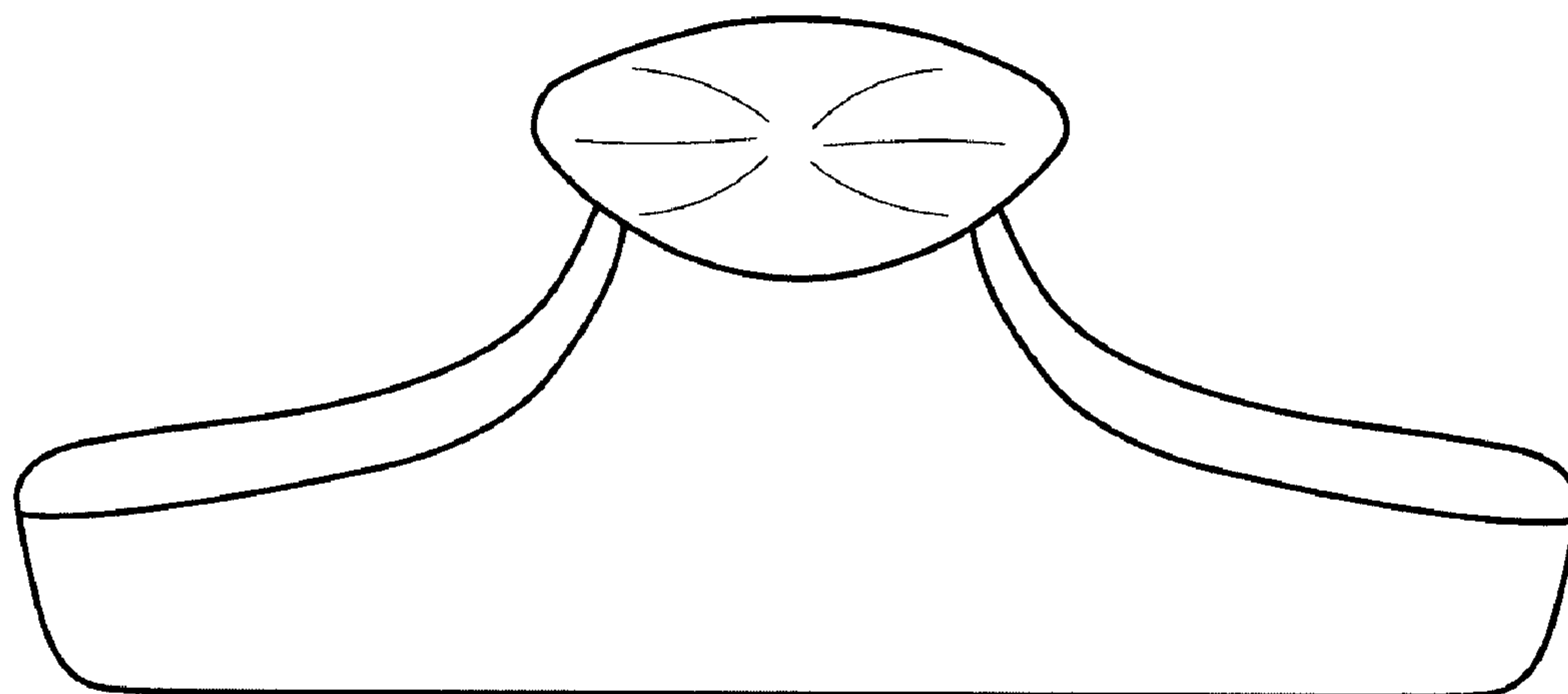

FIG. 49

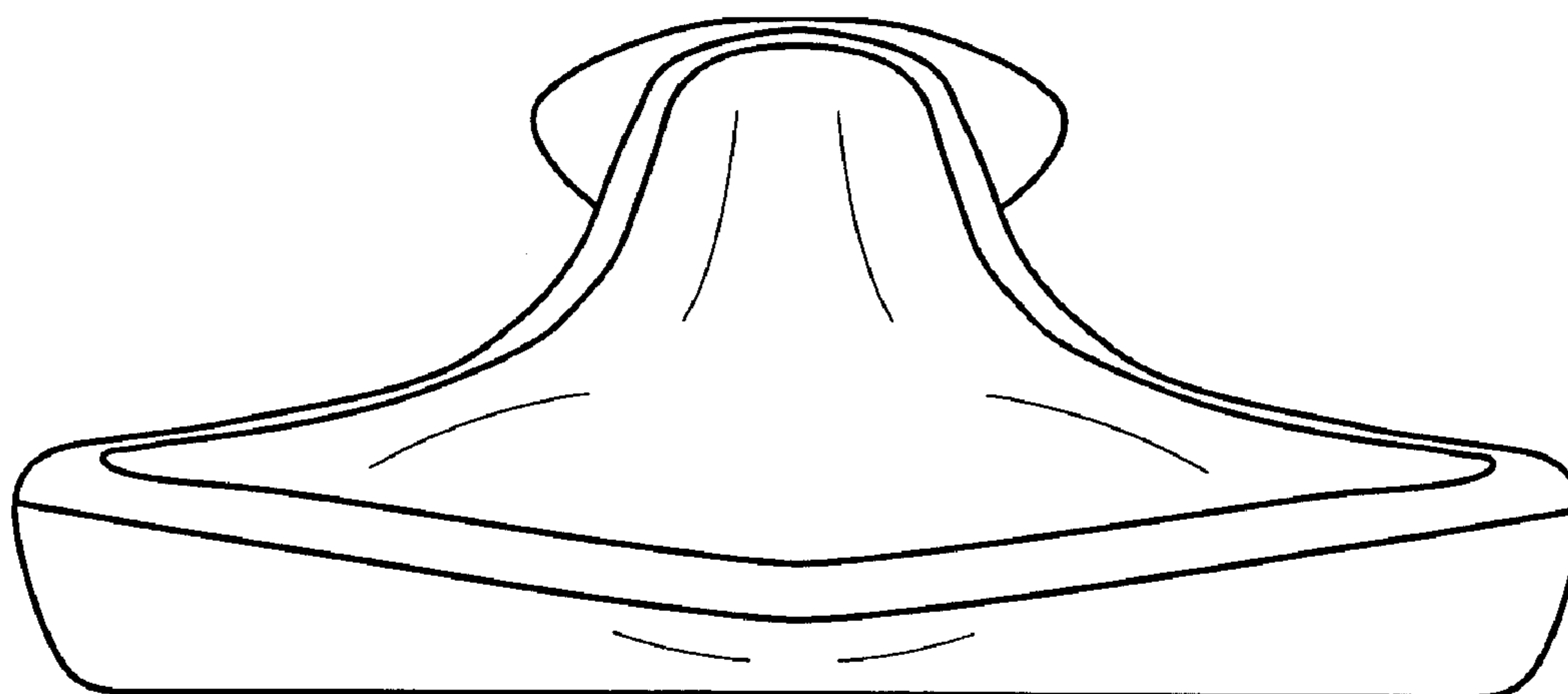

FIG. 50

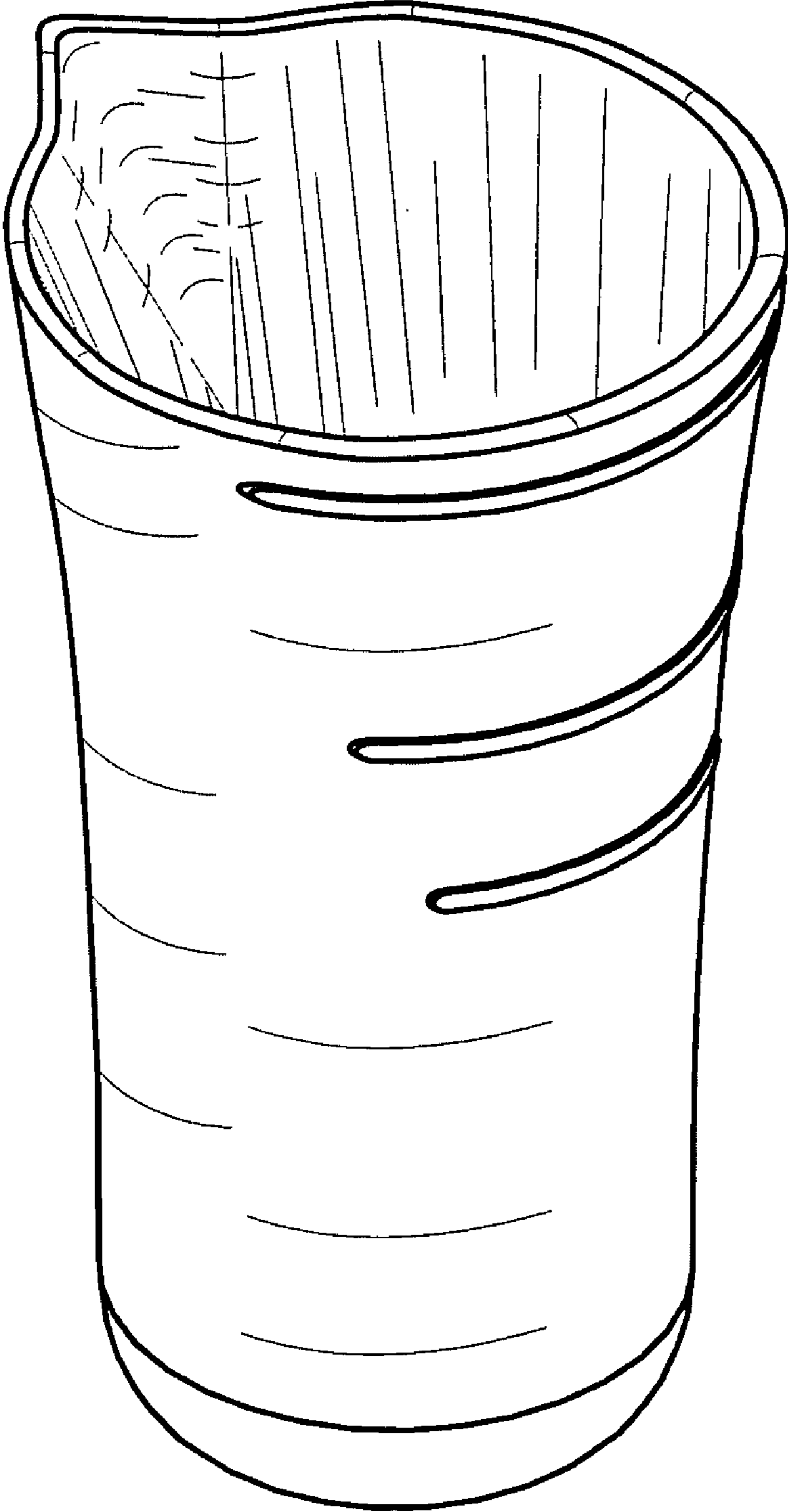

FIG. 51

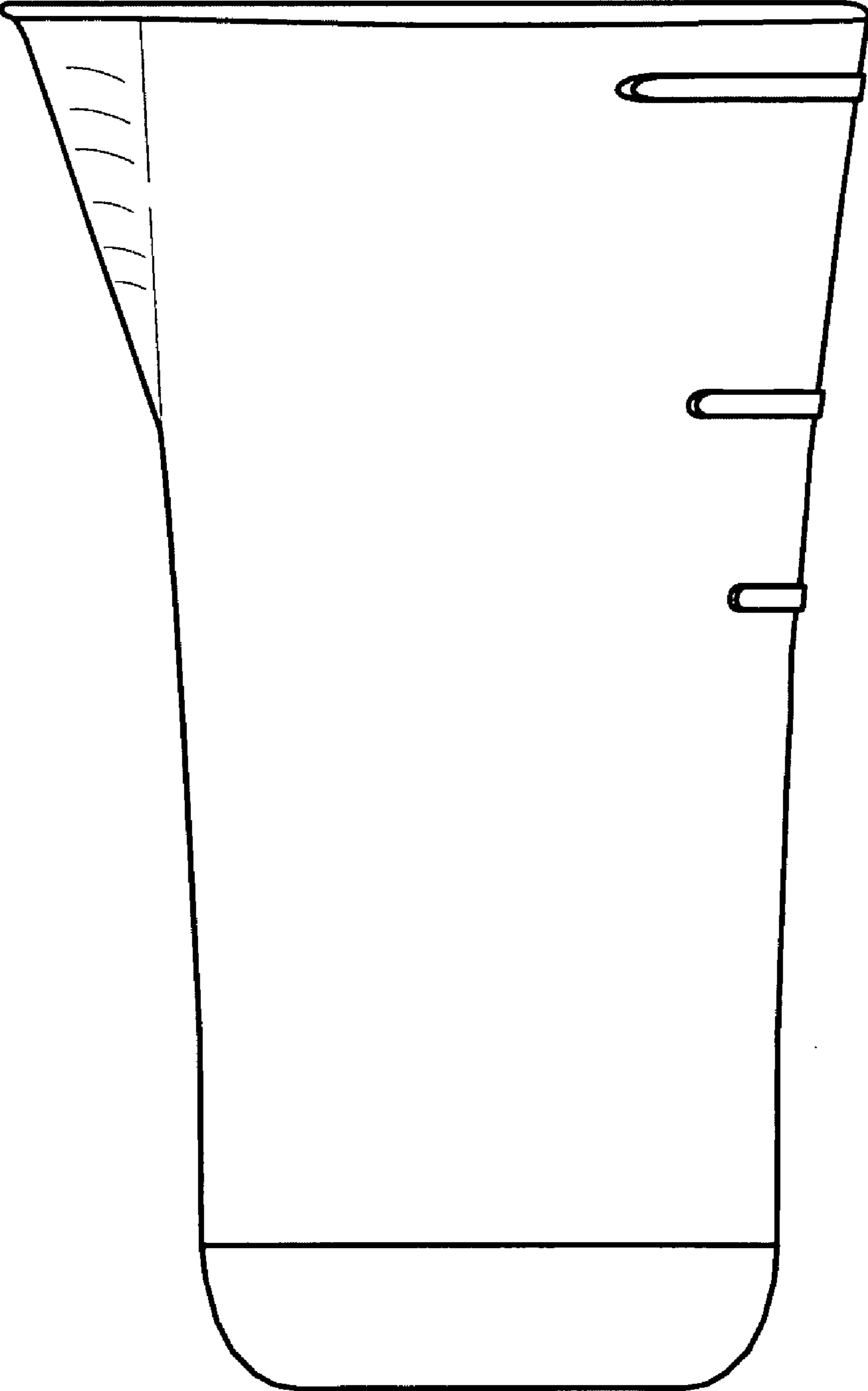

FIG. 52

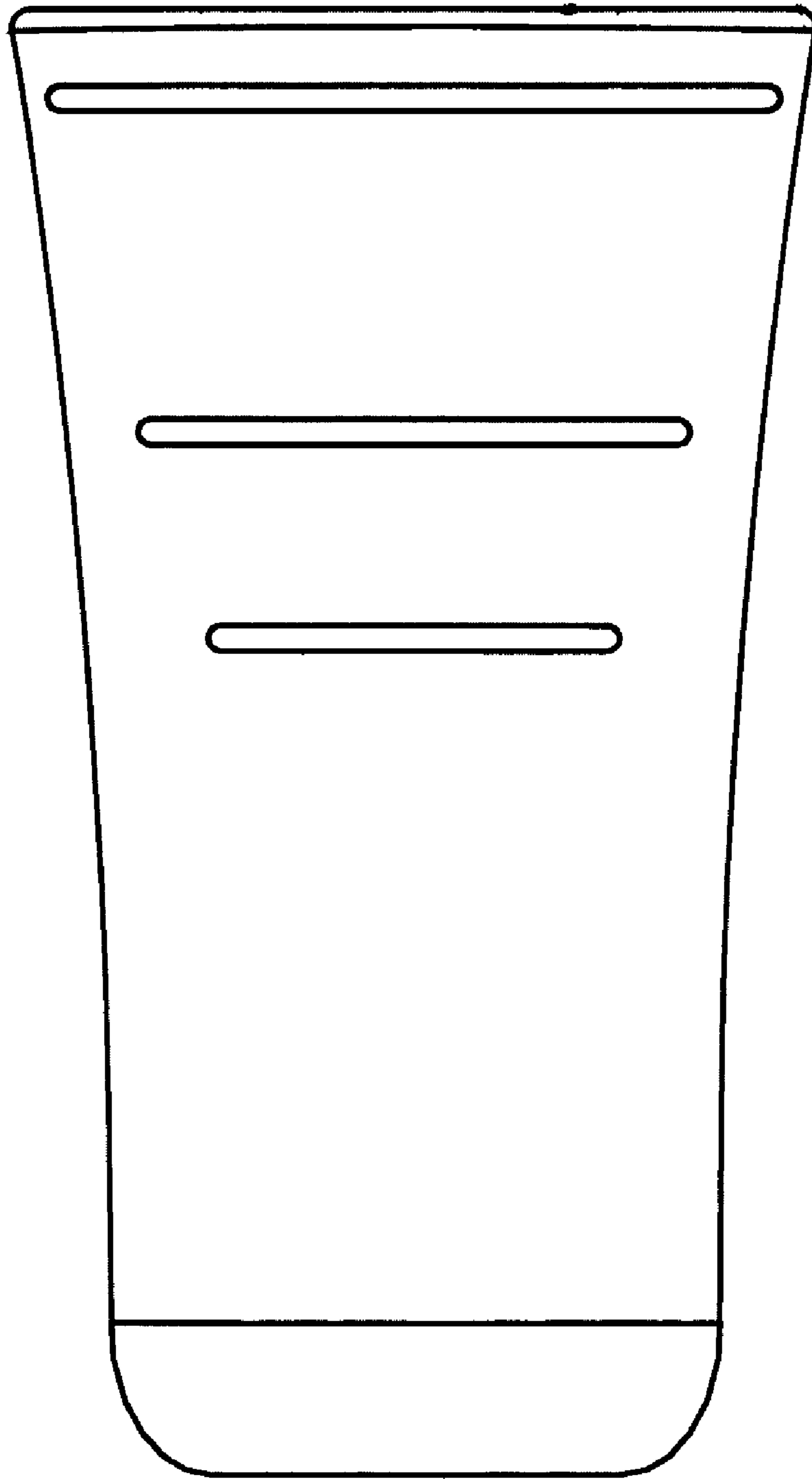

FIG. 53

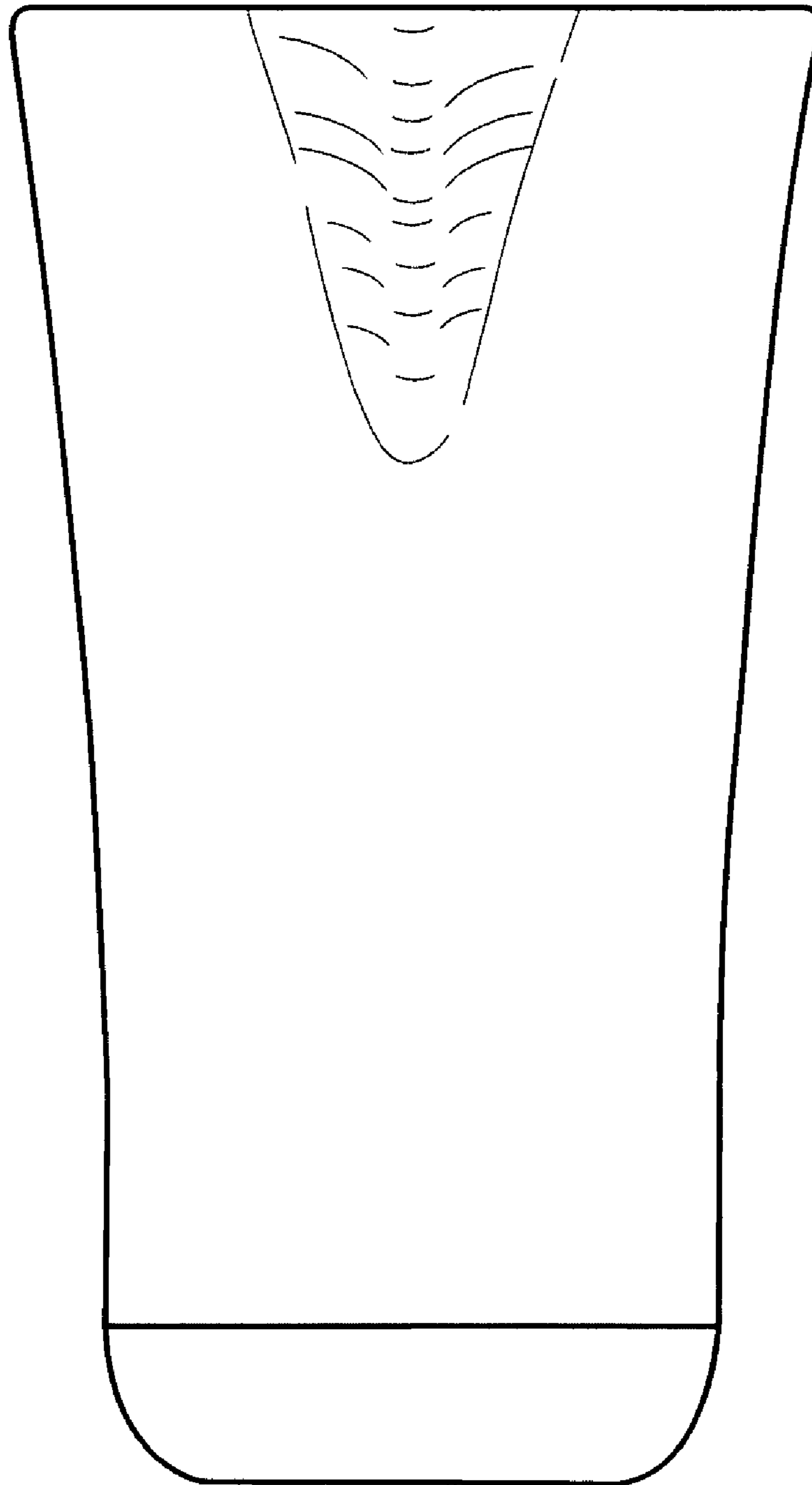

FIG. 54

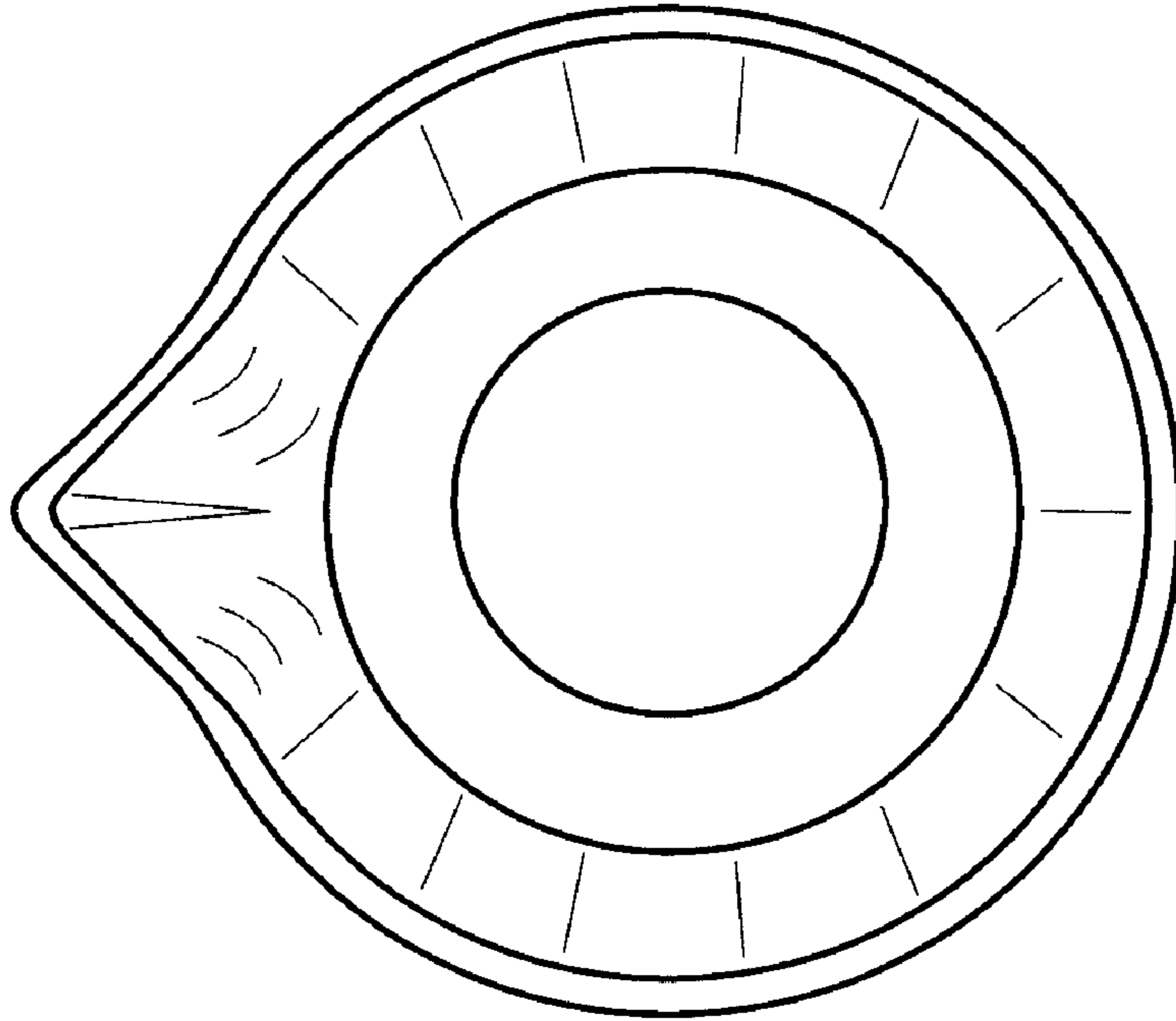

FIG. 55

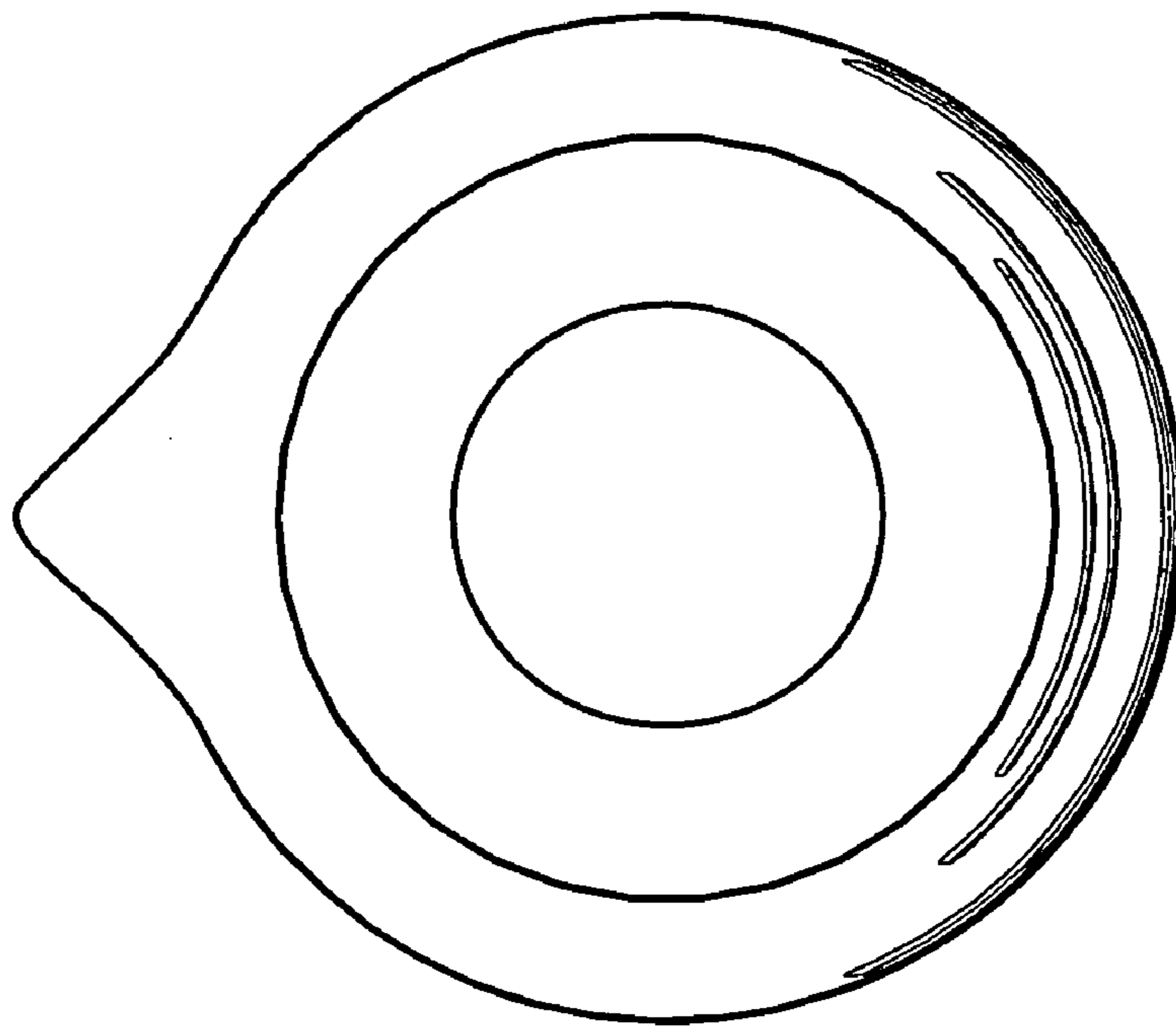

FIG. 56