



US00D630353S

(12) **United States Design Patent**
Reinbach

(10) **Patent No.:** **US D630,353 S**

(45) **Date of Patent:** **** *Jan. 4, 2011**

(54) **VEHICLE RUNNING LAMP**

D372,995 S * 8/1996 Huang D26/28
D390,980 S * 2/1998 Yamamoto D26/28

(75) Inventor: **Martin C. F. Reinbach**, Pakuranga (NZ)

* cited by examiner

(73) Assignee: **Hella New Zealand Limited**, Manukau (AU)

Primary Examiner—Marcus A Jackson
(74) *Attorney, Agent, or Firm*—Stites & Harbison PLLC; Douglas E. Jackson

(*) Notice: This patent is subject to a terminal disclaimer.

(**) Term: **14 Years**

(57) **CLAIM**

(21) Appl. No.: **29/352,085**

The ornamental design for a vehicle running lamp, as shown and described.

(22) Filed: **Dec. 16, 2009**

DESCRIPTION

(30) **Foreign Application Priority Data**

Jun. 17, 2009 (AU) 12205/2009

FIG. 1 is front view showing the new design.
FIG. 2 is a top view thereof.
FIG. 3 is a left side view thereof, the right side being a mirror image.
FIG. 4 is a bottom view thereof.
FIG. 5 is rear view thereof.
FIG. 6 is a cross sectional perspective top front and left side view with a cross section showing the perimeter outline thereof.
FIG. 7 is a perspective top front and left side view thereof; and,
FIG. 8 is a perspective top rear and left side view thereof.

(51) **LOC (9) Cl.** **26-04**

(52) **U.S. Cl.** **D26/28**

(58) **Field of Classification Search** D26/28-36;
362/459-468, 475-478, 485-487

See application file for complete search history.

(56) **References Cited**

U.S. PATENT DOCUMENTS

D289,205 S * 4/1987 Biggs D26/28

D304,504 S * 11/1989 Chen D26/28

D357,329 S * 4/1995 Iacovelli D26/28

1 Claim, 3 Drawing Sheets

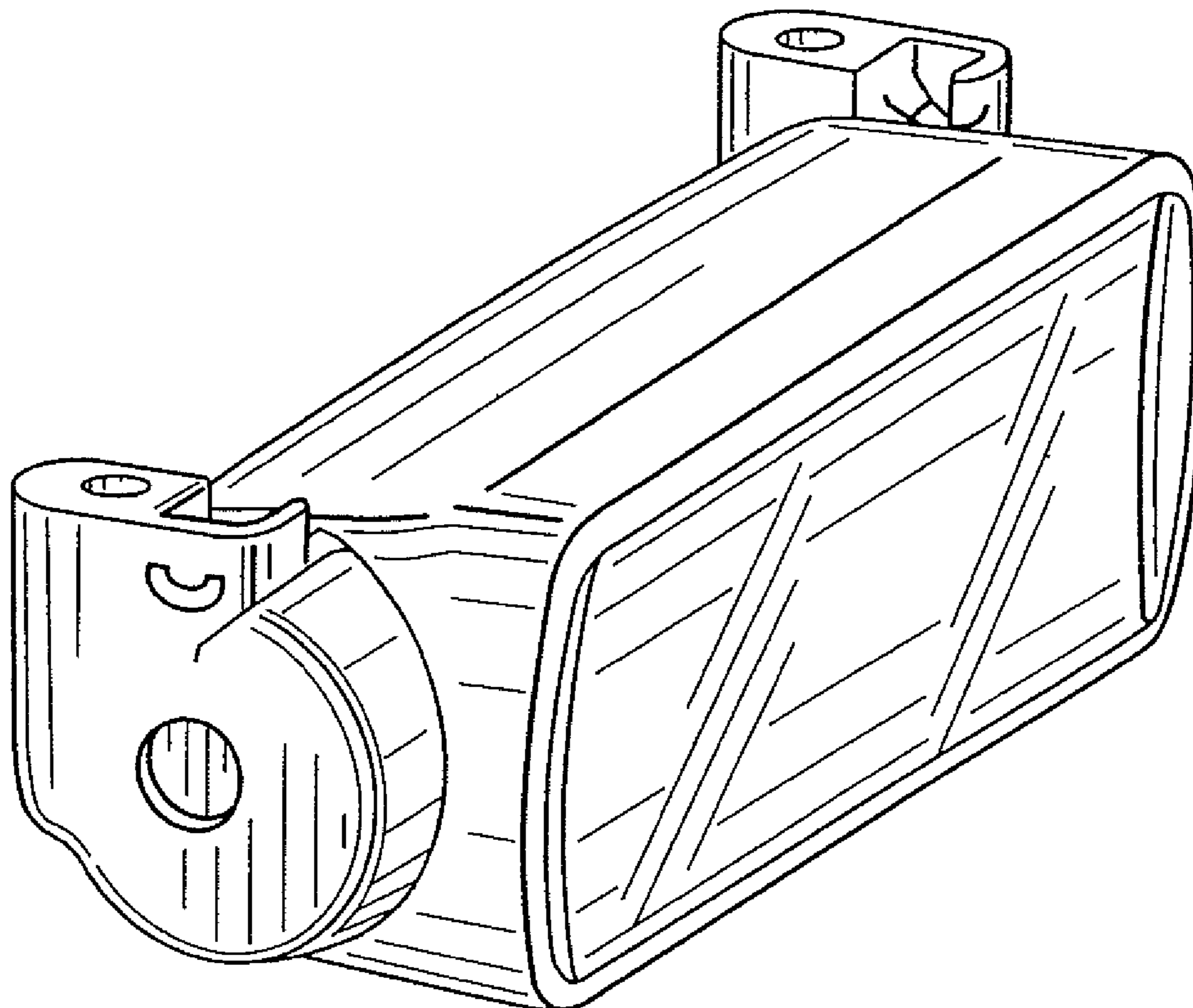

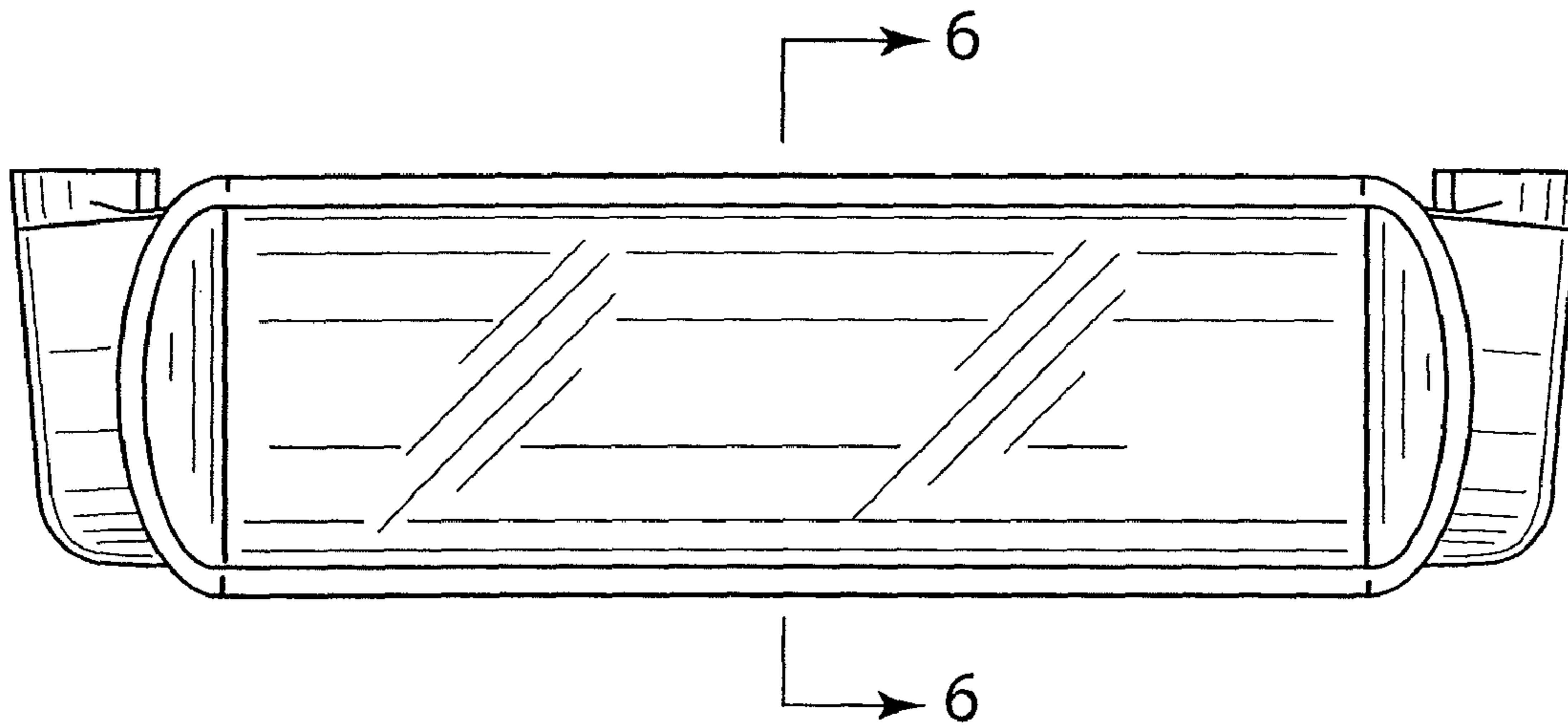

Fig. 1

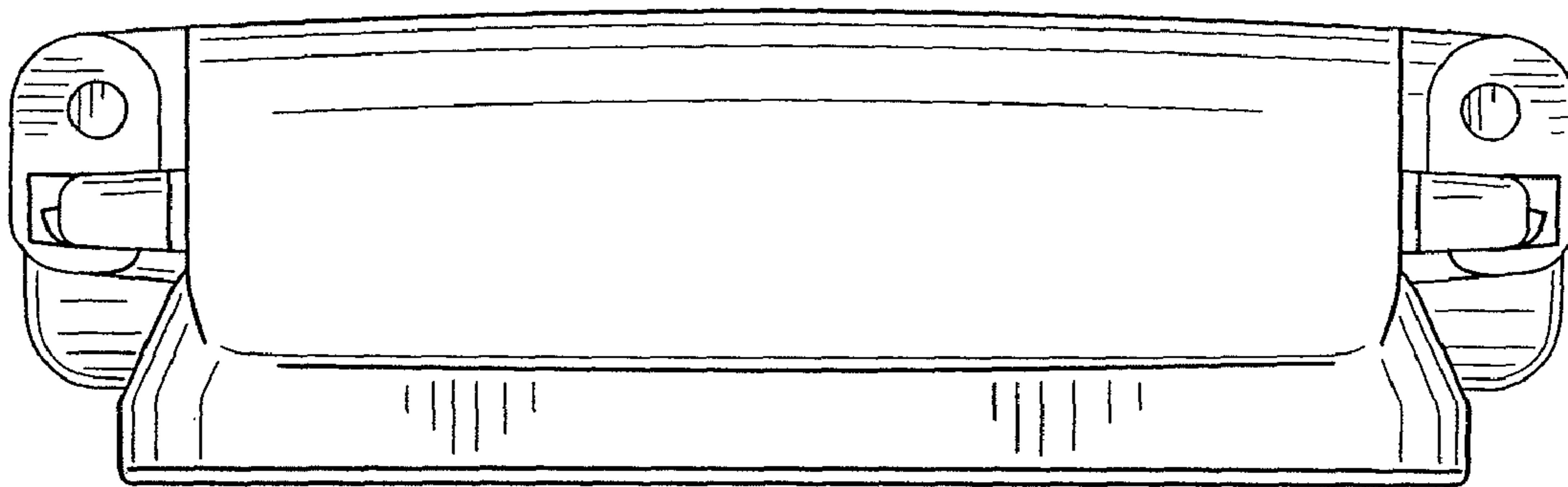

Fig. 2

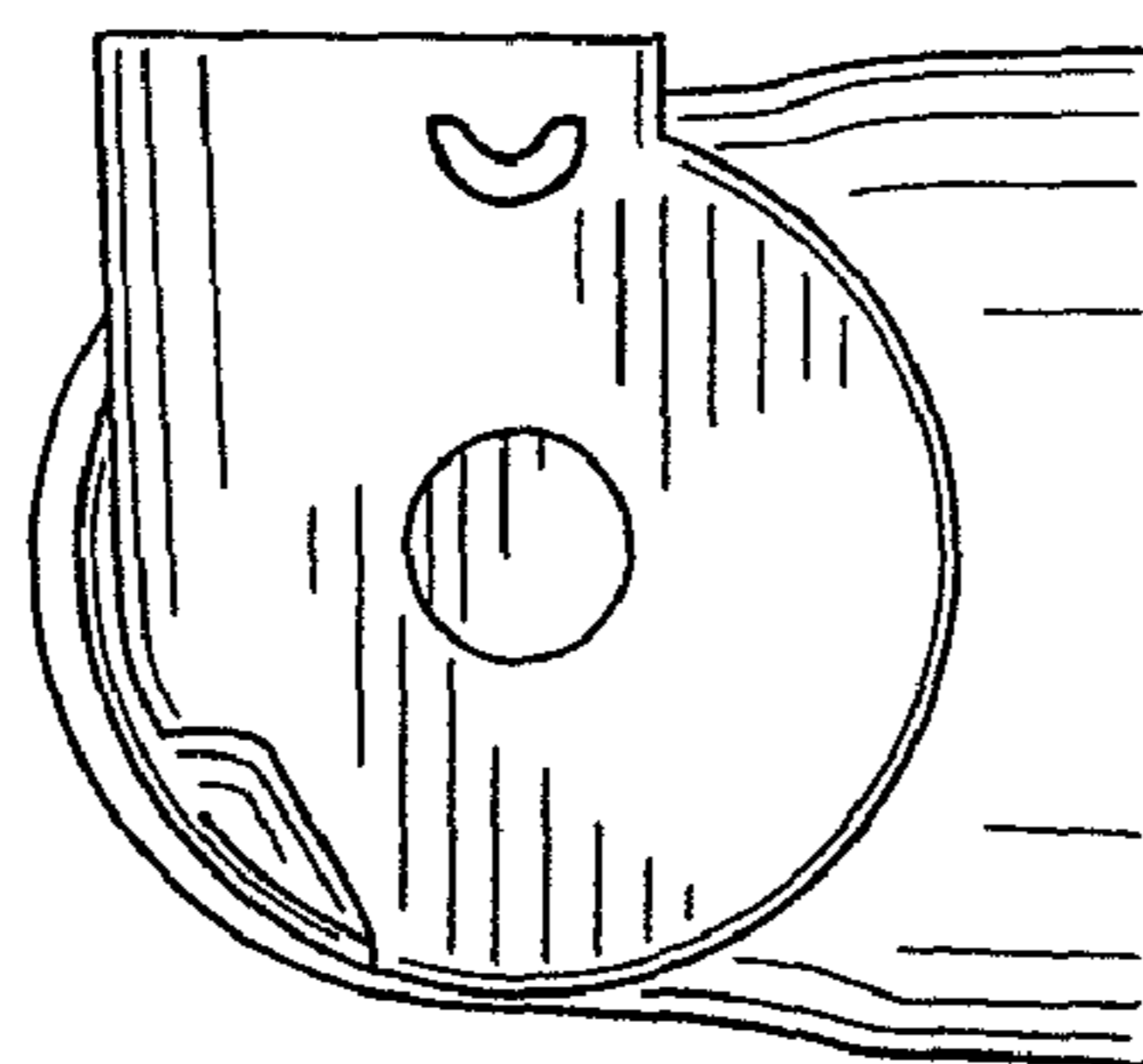

Fig. 3

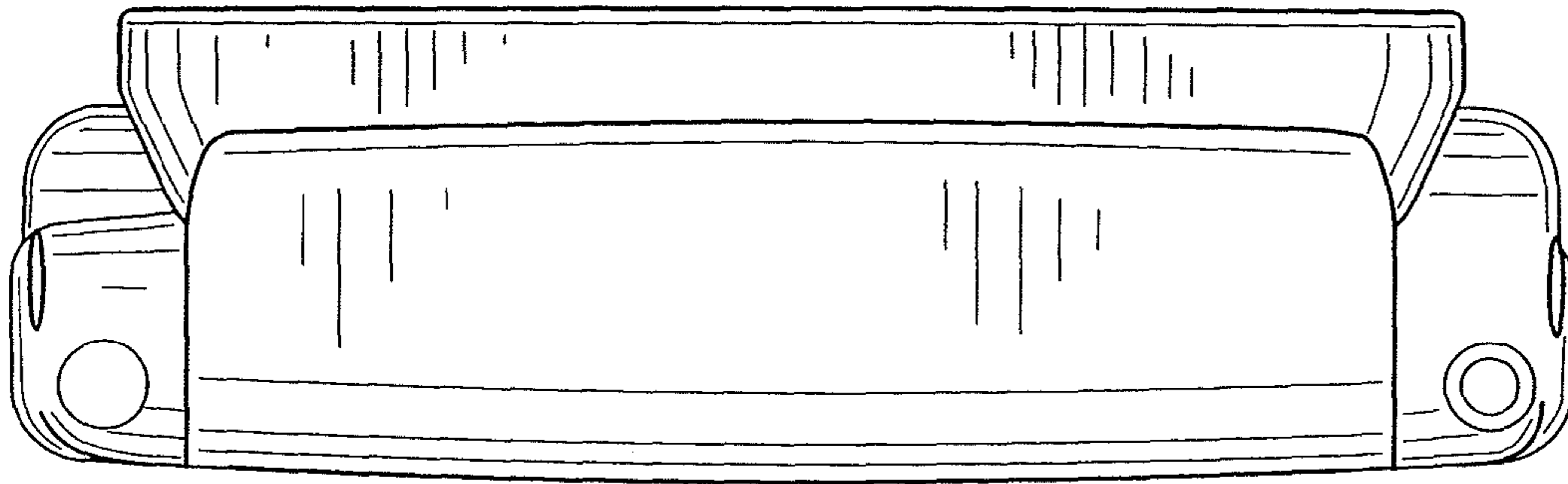

Fig. 4

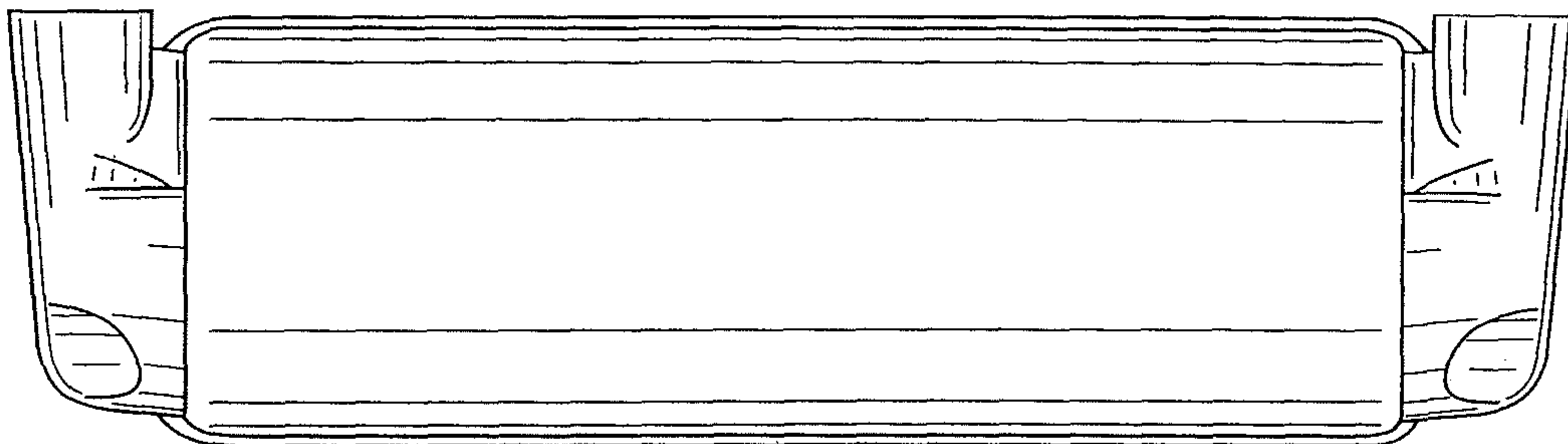

Fig. 5

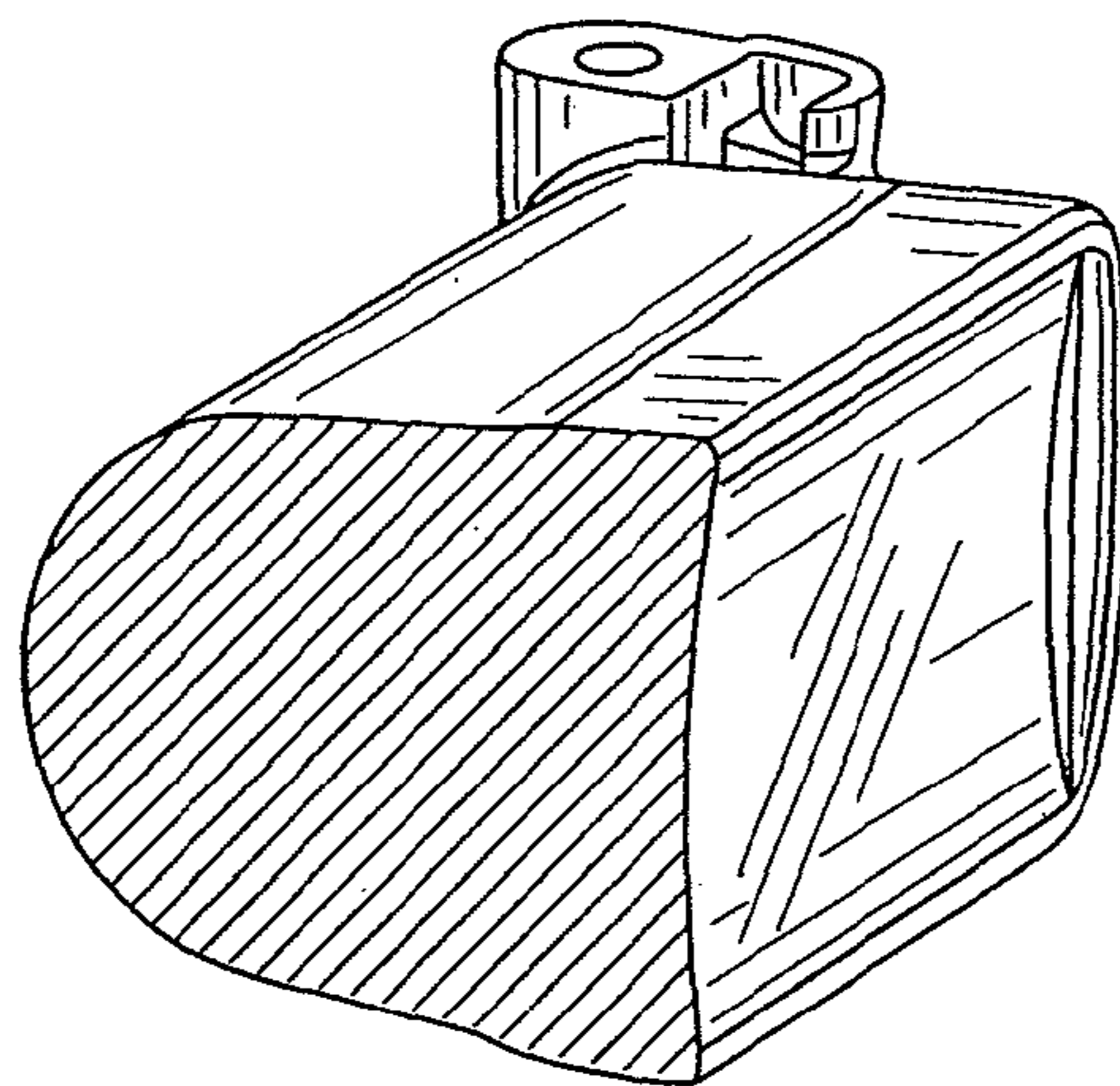

Fig. 6

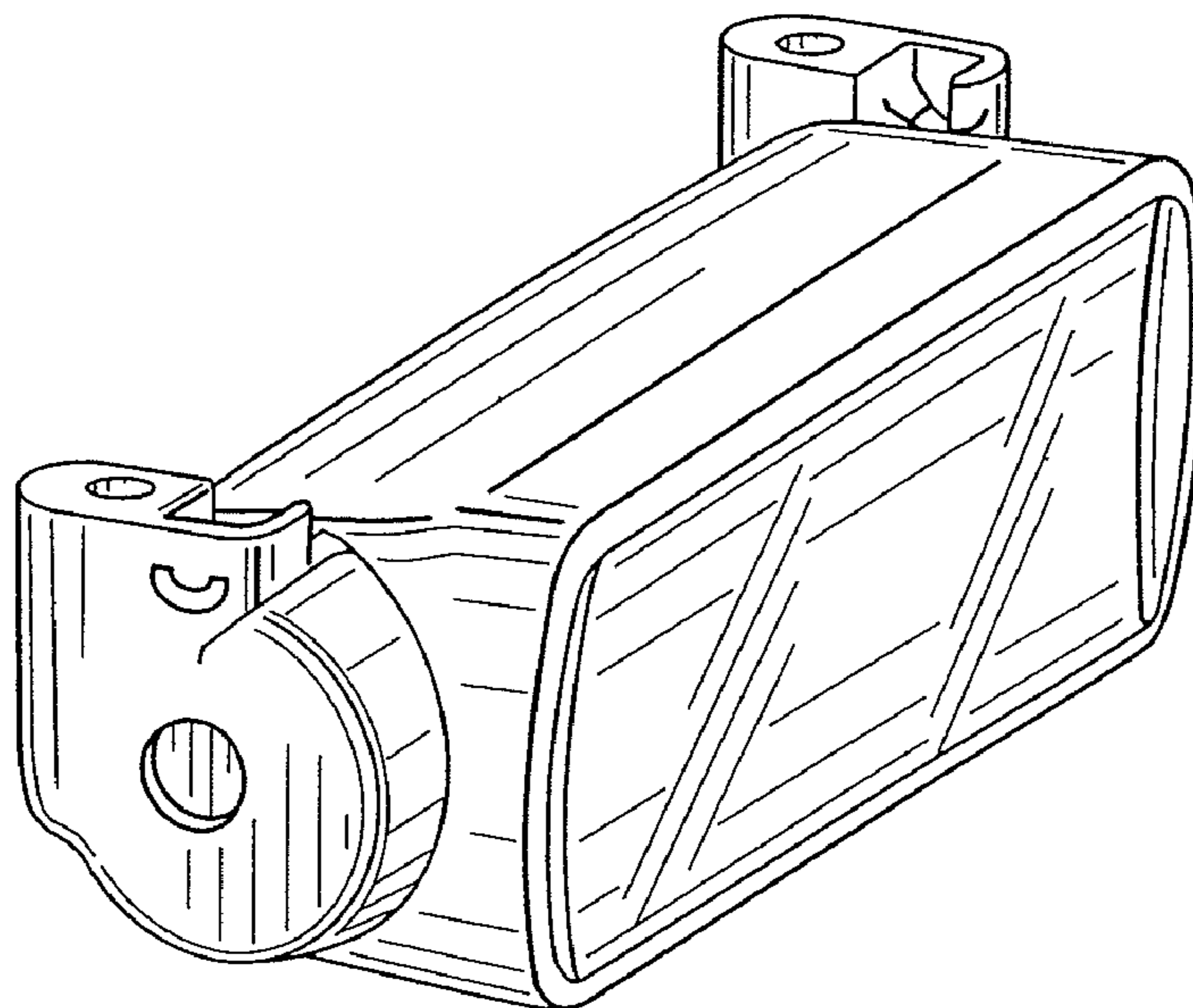

Fig. 7

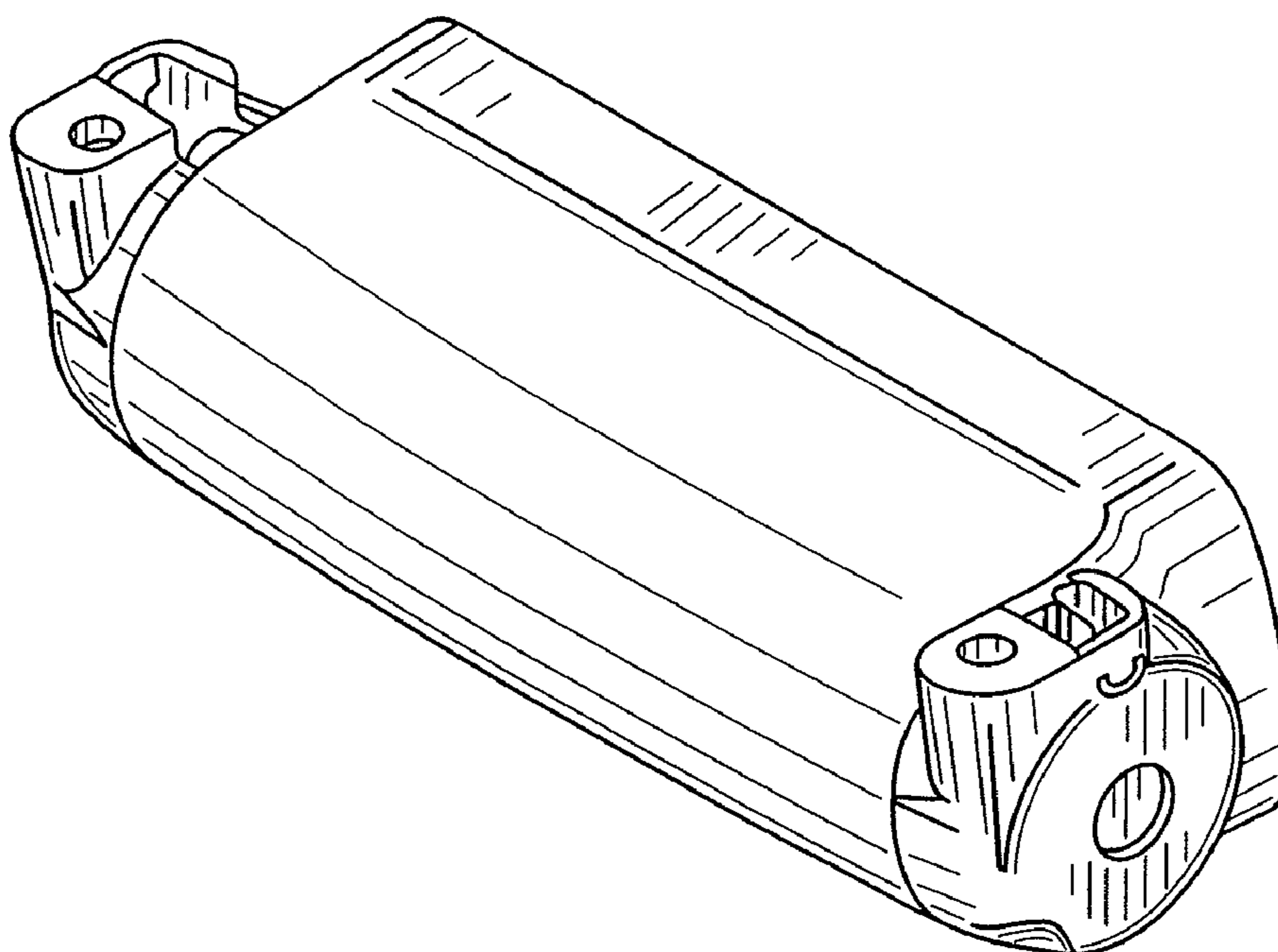

Fig. 8