



US00D630238S

(12) **United States Design Patent**
Fukuma et al.

(10) **Patent No.:** **US D630,238 S**
(45) **Date of Patent:** **** Jan. 4, 2011**

(54) **CAMERA STAND**

(75) Inventors: **Yohei Fukuma**, Tokyo (JP); **Satoshi Masamitsu**, Tokyo (JP)

(73) Assignee: **Sony Corporation**, Tokyo (JP)

(**) Term: **14 Years**

(21) Appl. No.: **29/356,768**

(22) Filed: **Mar. 2, 2010**

(30) **Foreign Application Priority Data**

Oct. 5, 2009 (JP) D2009-023139

(51) **LOC (9) Cl.** **16-05**

(52) **U.S. Cl.** **D16/242**

(58) **Field of Classification Search** D13/107,
D13/108; D16/208, 237, 242; 248/121,
248/122.1, 176.1, 187.1; 348/373; 396/419
See application file for complete search history.

(56) **References Cited**

U.S. PATENT DOCUMENTS

D349,125 S *	7/1994	Wilson et al.	D16/208
D459,299 S	6/2002	Hughes et al.		
D460,971 S	7/2002	Sica et al.		
D463,361 S	9/2002	Ruohonen		
D502,913 S *	3/2005	Fukami et al.	D13/108
D508,459 S	8/2005	Yoshida		
D510,091 S	9/2005	Mori et al.		
D511,492 S	11/2005	Allende Fritsch		
D515,609 S *	2/2006	Heatherly et al.	D16/242
D525,616 S	7/2006	Andre et al.		
7,075,579 B2	7/2006	Whitby et al.		
7,145,603 B2	12/2006	Whitby et al.		
D544,899 S *	6/2007	Li et al.	D16/242
D549,169 S	8/2007	Watson		

D552,597 S	10/2007	Solland		
D553,123 S	10/2007	Solland		
D594,404 S *	6/2009	Kuo et al.	D13/107
D610,601 S *	2/2010	Melder	D16/242
2007/0210220 A1 *	9/2007	Sawai et al.	248/122.1

FOREIGN PATENT DOCUMENTS

JP	D1058003 S	1/2000
JP	D1151032 S	8/2002
JP	D1236808 S	4/2005
JP	D1239163 S	5/2005
JP	D1322417 S	2/2008
TW	D121228 S	2/2008

* cited by examiner

Primary Examiner—Adir Aronovich

(74) *Attorney, Agent, or Firm*—Rader, Fishman & Grauer PLLC

(57) **CLAIM**

The ornamental design for a camera stand, as shown and described.

DESCRIPTION

FIG. 1 is a perspective view of a camera stand showing our new design;

FIG. 2 is a front elevational view, thereof;

FIG. 3 is a rear elevational view thereof;

FIG. 4 is a left side elevational view thereof;

FIG. 5 is a right side elevational view thereof; and,

FIG. 6 is a top plan view thereof.

Portions in broken lines are for illustrative purpose only and form no part of claimed design. The dot-dash broken lines define, but are not included in, the boundaries of the claimed design.

1 Claim, 4 Drawing Sheets

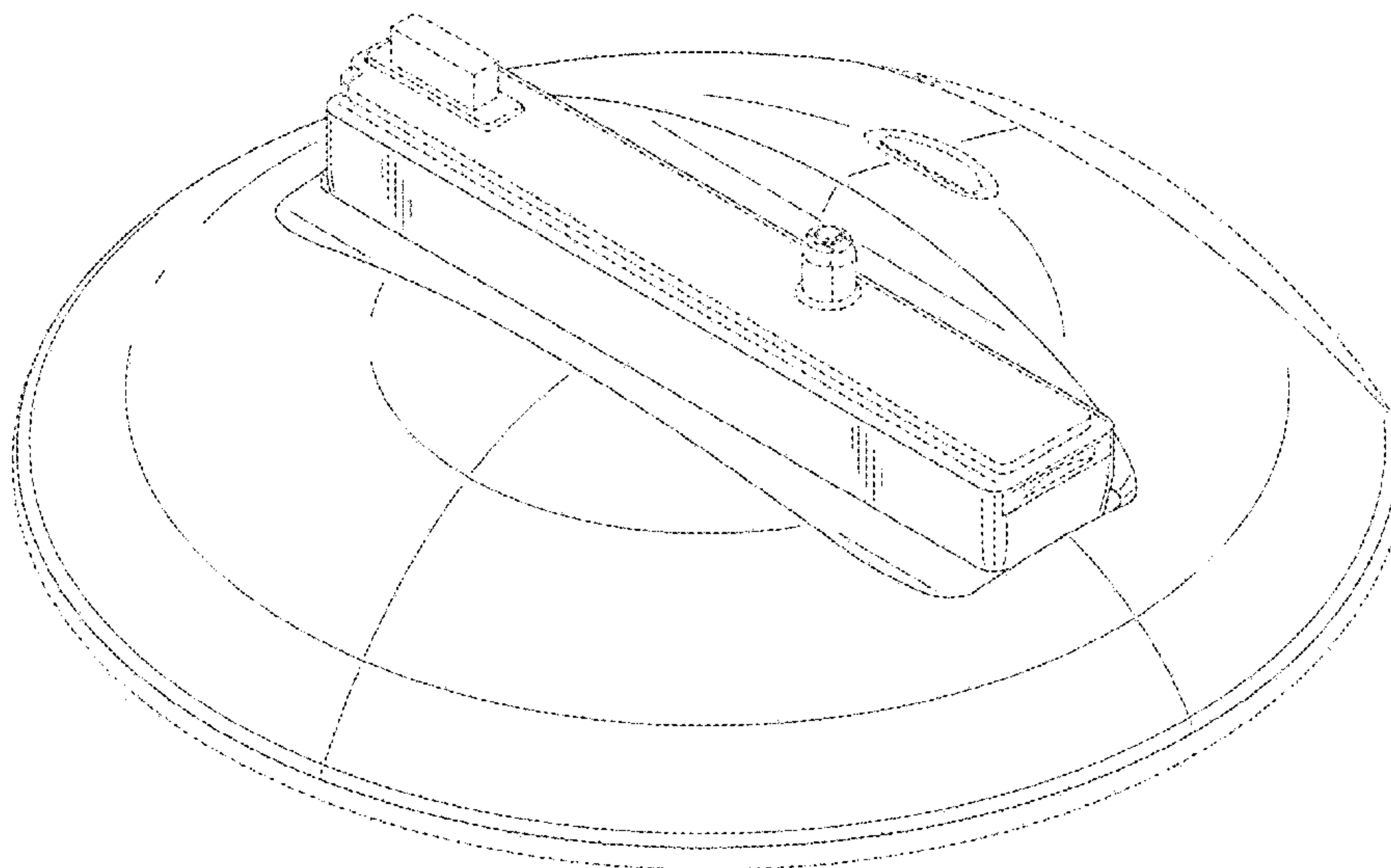
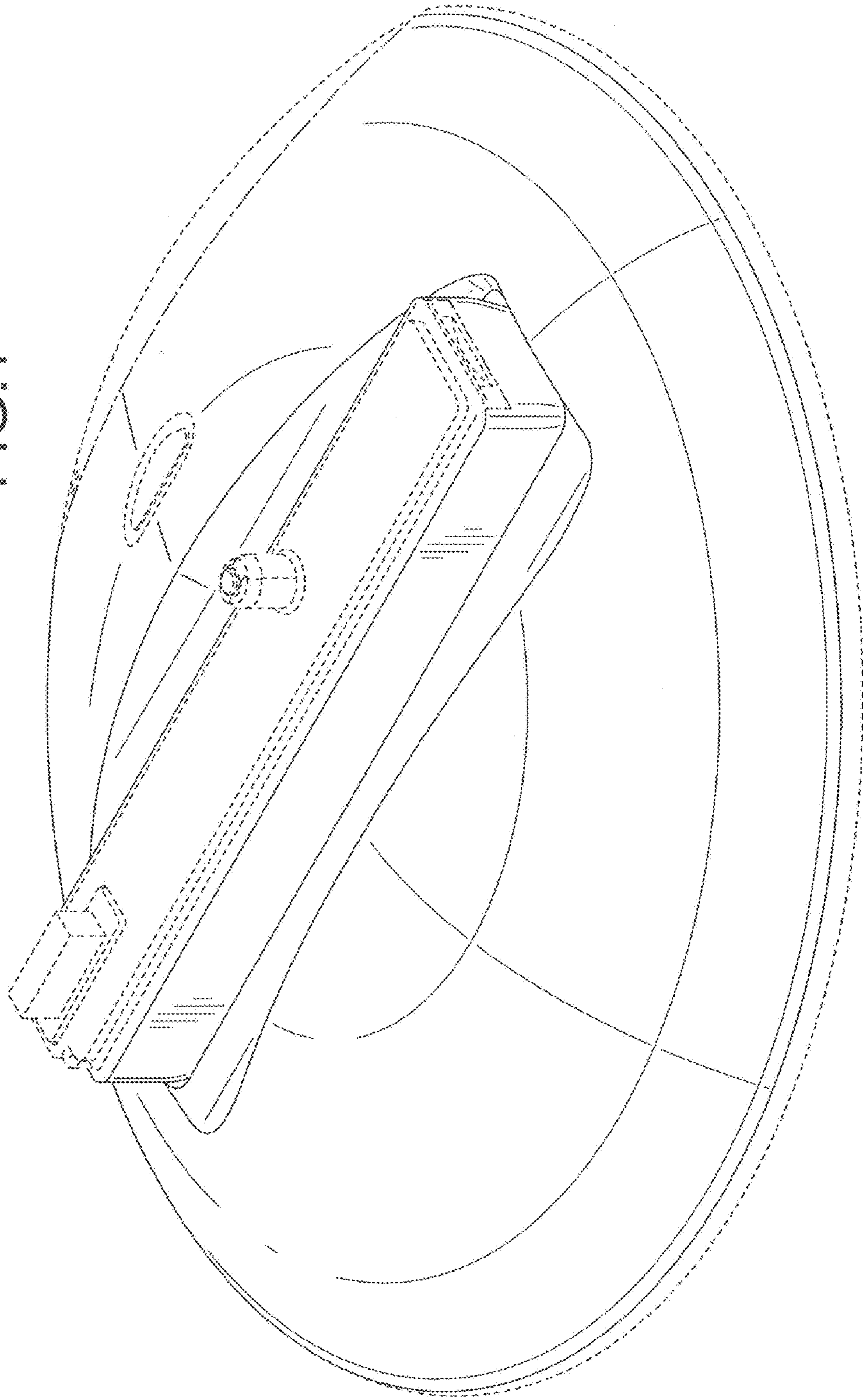

FIG.1



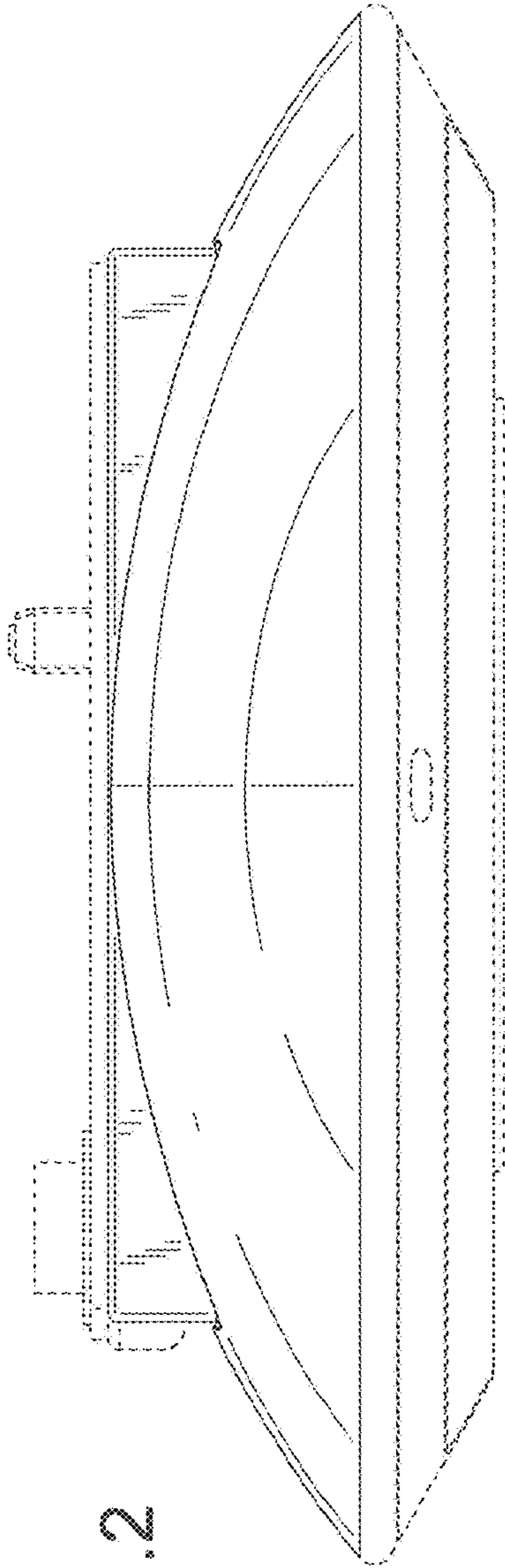

FIG. 2

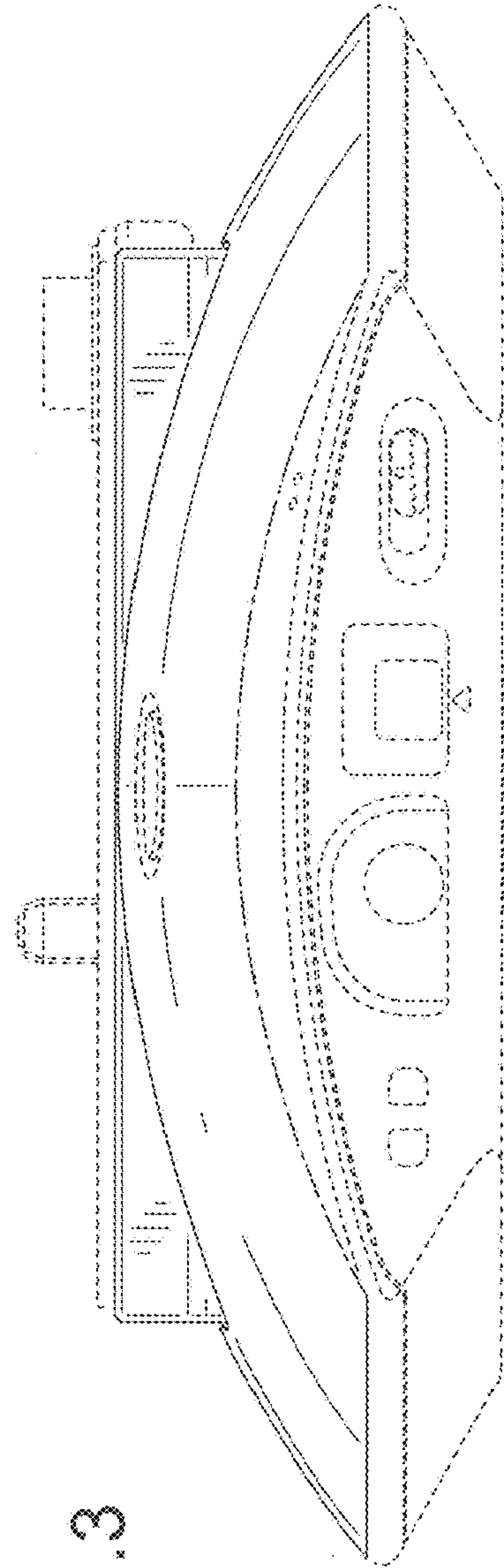

FIG. 3

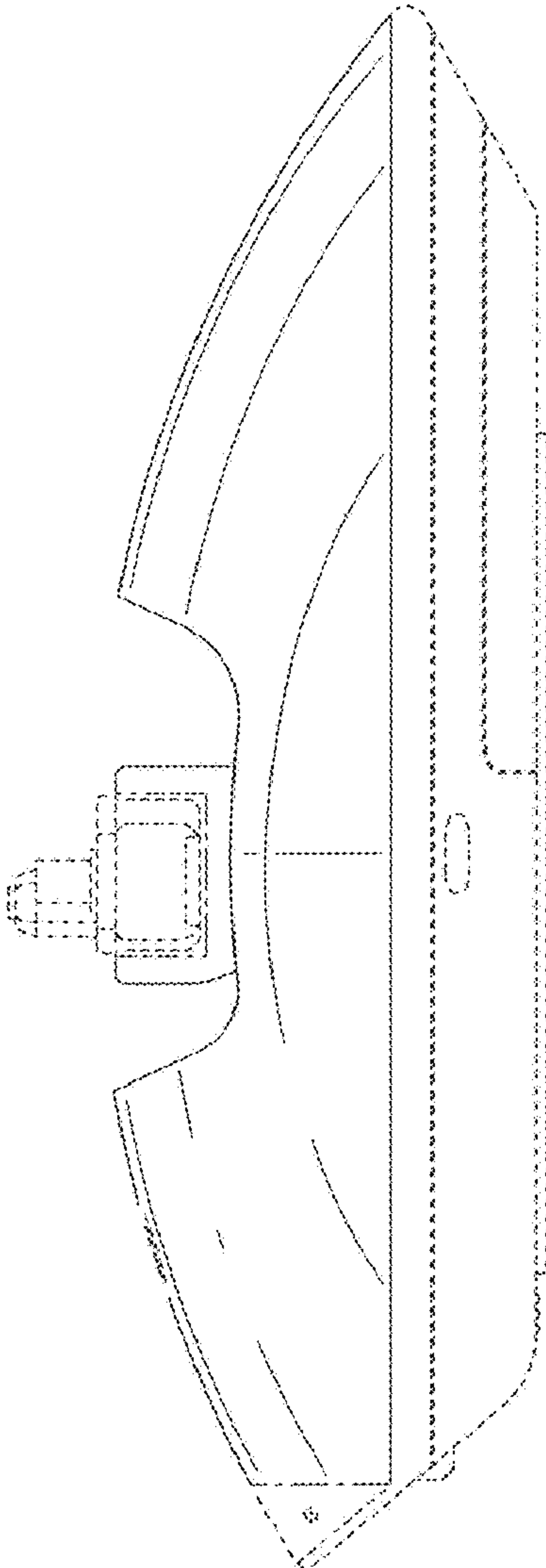

FIG. 4

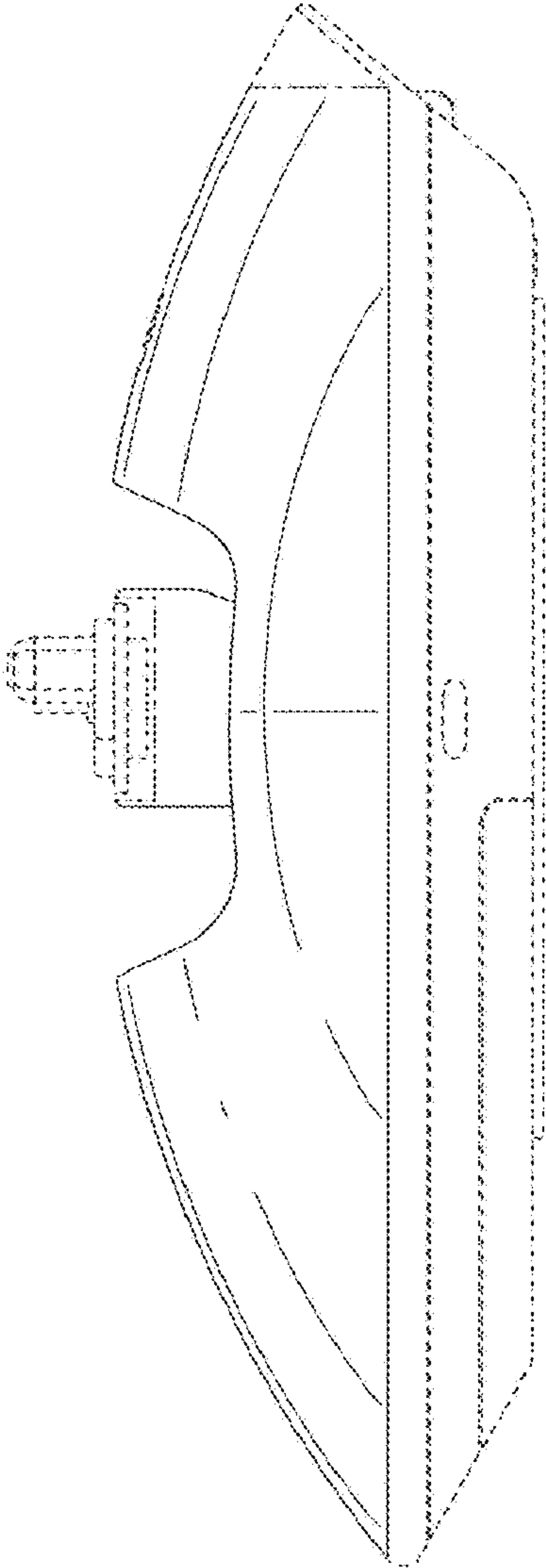

FIG. 5

FIG.6

