



US00D630154S

(12) **United States Design Patent**
Cote et al.

(10) **Patent No.:** **US D630,154 S**
(45) **Date of Patent:** **** Jan. 4, 2011**

(54) **PERSONAL WATERCRAFT REAR HANDLE**

(75) Inventors: **Andre Cote**, Longueuil (CA); **Steve Tetreault**, Sherbrooke (CA); **Luc Lapointe**, Sherbrooke (CA); **Alexandre Curthelet**, Granby (CA); **Jacques Mayrand**, Sherbrooke (CA); **Alex Miklosi**, Sheboygan, WI (US)

(73) Assignee: **Bombardier Recreational Products Inc.**, Valcourt (CA)

(**) Term: **14 Years**

(21) Appl. No.: **29/336,084**

(22) Filed: **Apr. 28, 2009**

Related U.S. Application Data

(63) Continuation-in-part of application No. 29/324,023, filed on Sep. 4, 2008.

(51) **LOC (9) Cl.** **12-06**

(52) **U.S. Cl.** **D12/317; D12/307**

(58) **Field of Classification Search** **D12/7,**
D12/300, 307, 317; 114/55.5, 55.51-55.58,
114/71, 362

See application file for complete search history.

(56) **References Cited**

U.S. PATENT DOCUMENTS

D342,052 S * 12/1993 Schoell et al. D12/307

(Continued)

Primary Examiner—Cynthia M Chin

(74) *Attorney, Agent, or Firm*—Osler, Hoskin & Harcourt LLP

(57) **CLAIM**

The ornamental designs for a personal watercraft rear handle, as shown and described.

DESCRIPTION

FIG. 1 is a front left perspective view showing a personal watercraft rear handle according to our new design;

FIG. 2 is a rear elevation view thereof;

FIG. 3 is a front elevation view thereof;

FIG. 4 is a left side elevation view thereof;

FIG. 5 is a right side elevation view thereof;

FIG. 6 is a bottom plan view thereof;

FIG. 7 is a top plan view thereof;

FIG. 8 is a front left perspective view thereof on a personal watercraft, with the personal watercraft shown in broken lines;

FIG. 9 is a rear bottom right perspective view of the personal watercraft rear handle of FIG. 1;

FIG. 10 is a front left perspective view showing the personal watercraft rear handle of FIG. 1 with select broken-lined elements removed for the clarity of illustration;

FIG. 11 is a rear elevation view thereof;

FIG. 12 is a front elevation view thereof;

FIG. 13 is a left side elevation view thereof;

FIG. 14 is a right side elevation view thereof;

FIG. 15 is a bottom plan view thereof;

FIG. 16 is a top plan view thereof;

FIG. 17 is a front left perspective view thereof on a personal watercraft, with the personal watercraft shown in broken lines; and,

FIG. 18 is a rear bottom right perspective view thereof.

It is understood that unshaded surfaces adjacent broken lines form no part of the claim. Throughout the figures, where shown, the broken lines showing additional structure of the personal watercraft rear handle and the watercraft on which it is shown are for illustrative purposes only and form no part of the claimed design. Portions of the personal watercraft rear handle not shown in the Figures and not otherwise described in this Specification do not form part of the claimed design.

1 Claim, 16 Drawing Sheets

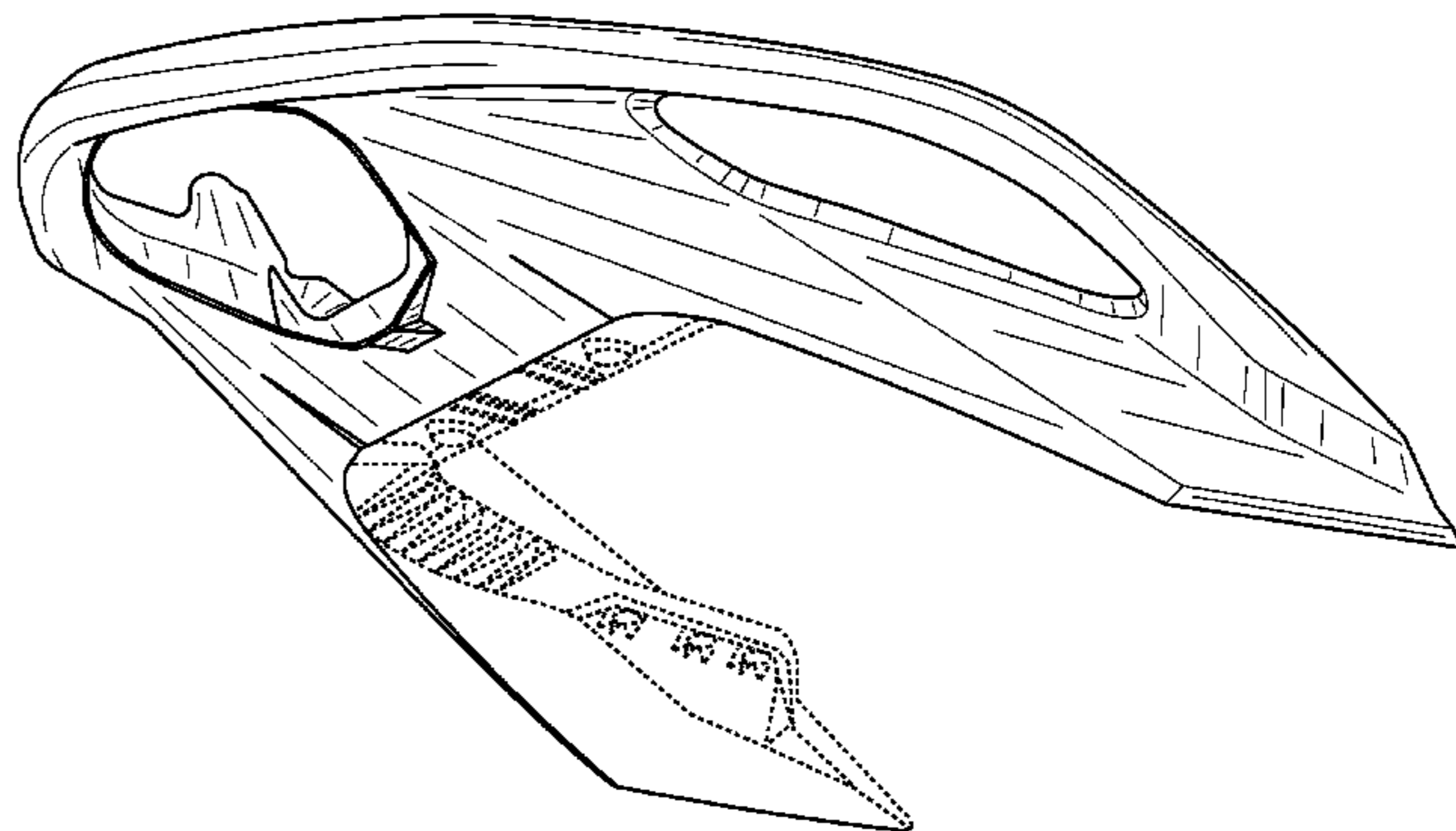
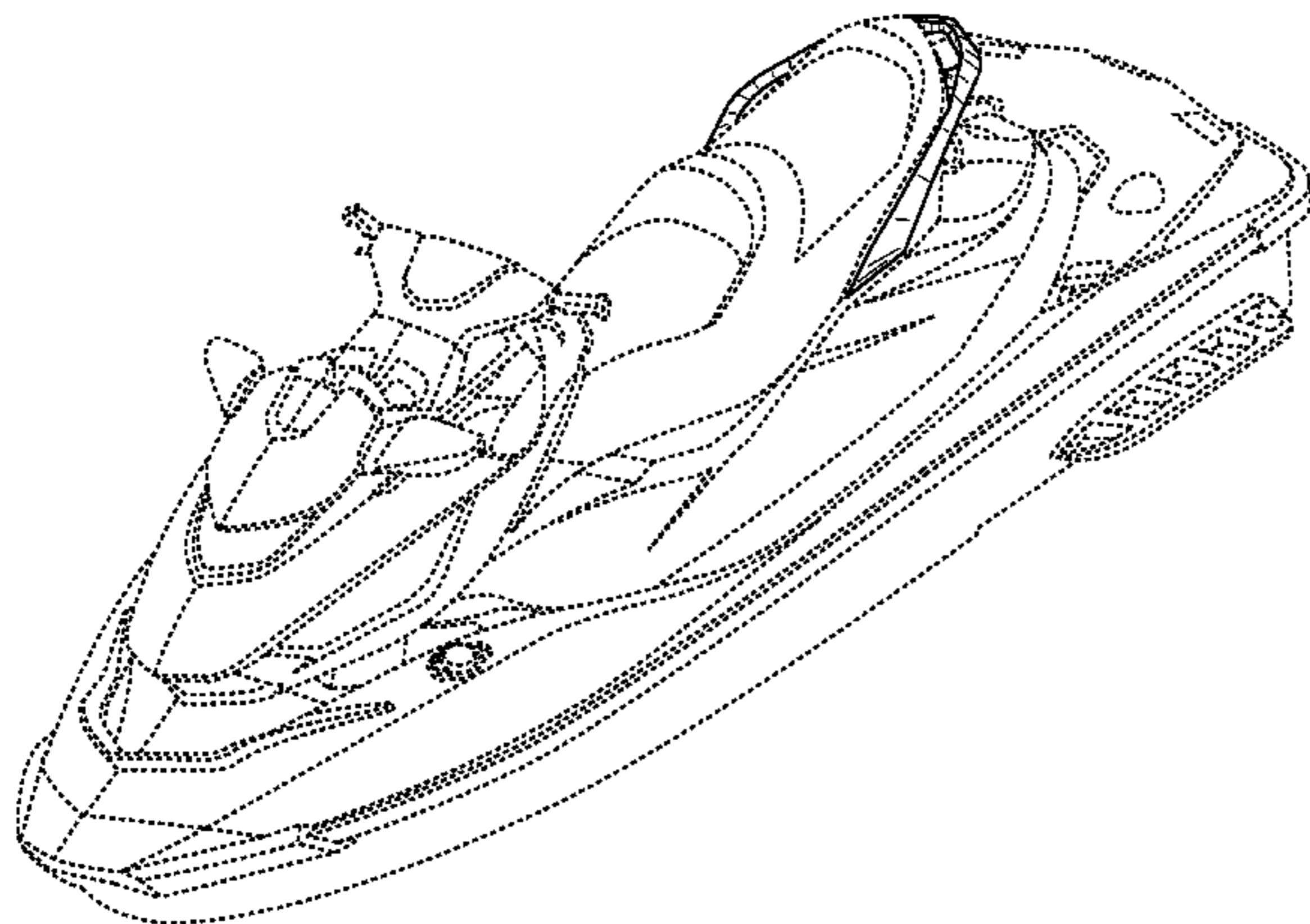

US D630,154 S

Page 2

U.S. PATENT DOCUMENTS

5,537,948	A *	7/1996	Kobayashi	114/55.57					
D399,182	S *	10/1998	Lapointe et al.	D12/307					
D463,355	S *	9/2002	Bucaccio et al.	D12/307					
D464,929	S *	10/2002	Aselton et al.	D12/307					
D487,421	S *	3/2004	Cassell et al.	D12/307					
D500,280	S *	12/2004	Cassell et al.	D12/307					
					D507,229	S *	7/2005	Bucaccio et al.	D12/307
					6,932,011	B2 *	8/2005	Nagata et al.	114/55.57
					D558,121	S *	12/2007	Shimizugami et al.	D12/307
					D558,122	S *	12/2007	Tanaka et al.	D12/307
					D569,781	S *	5/2008	Hattori et al.	D12/307
					2004/0168622	A1 *	9/2004	Thompson et al.	114/55.5

* cited by examiner

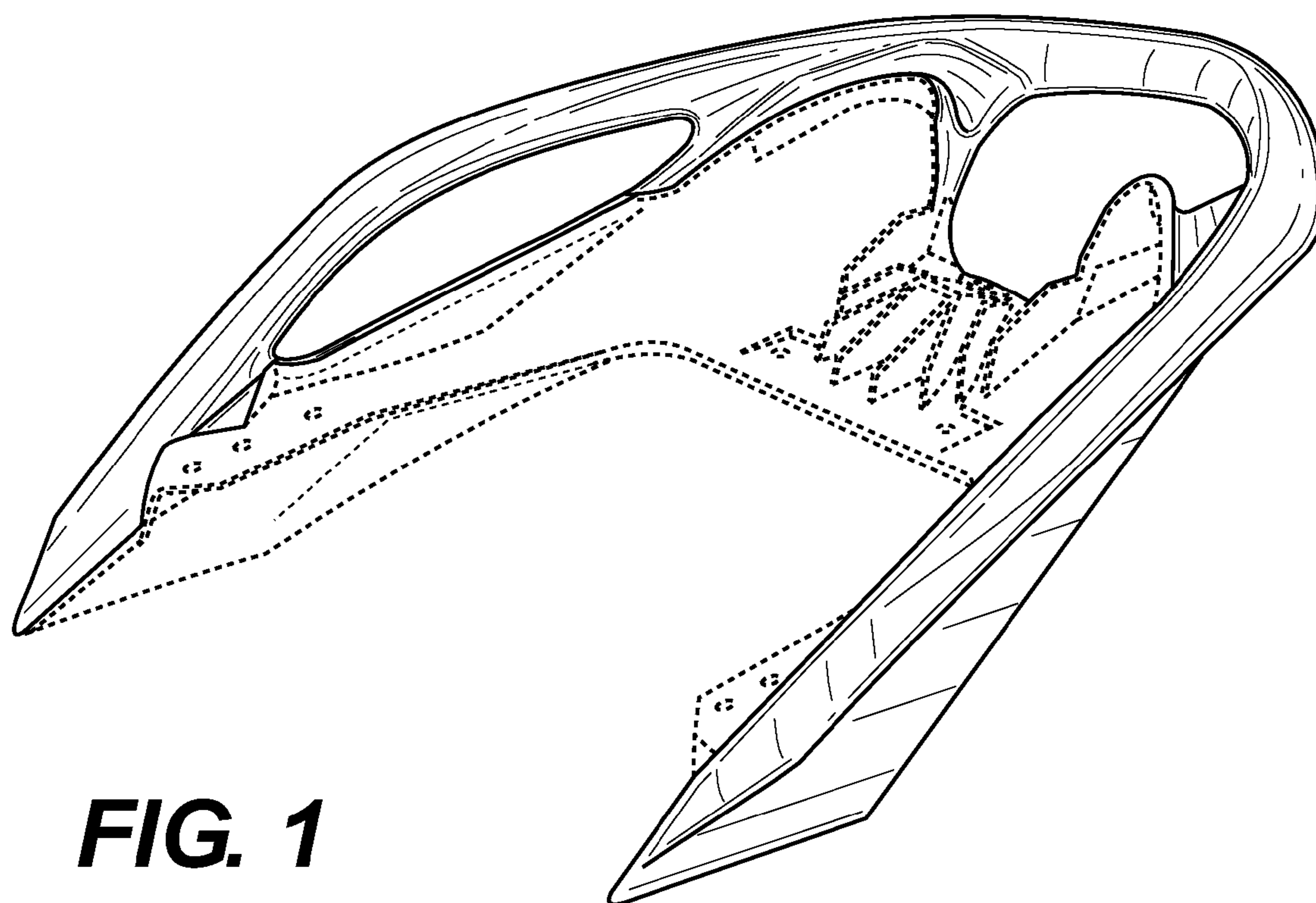

FIG. 1

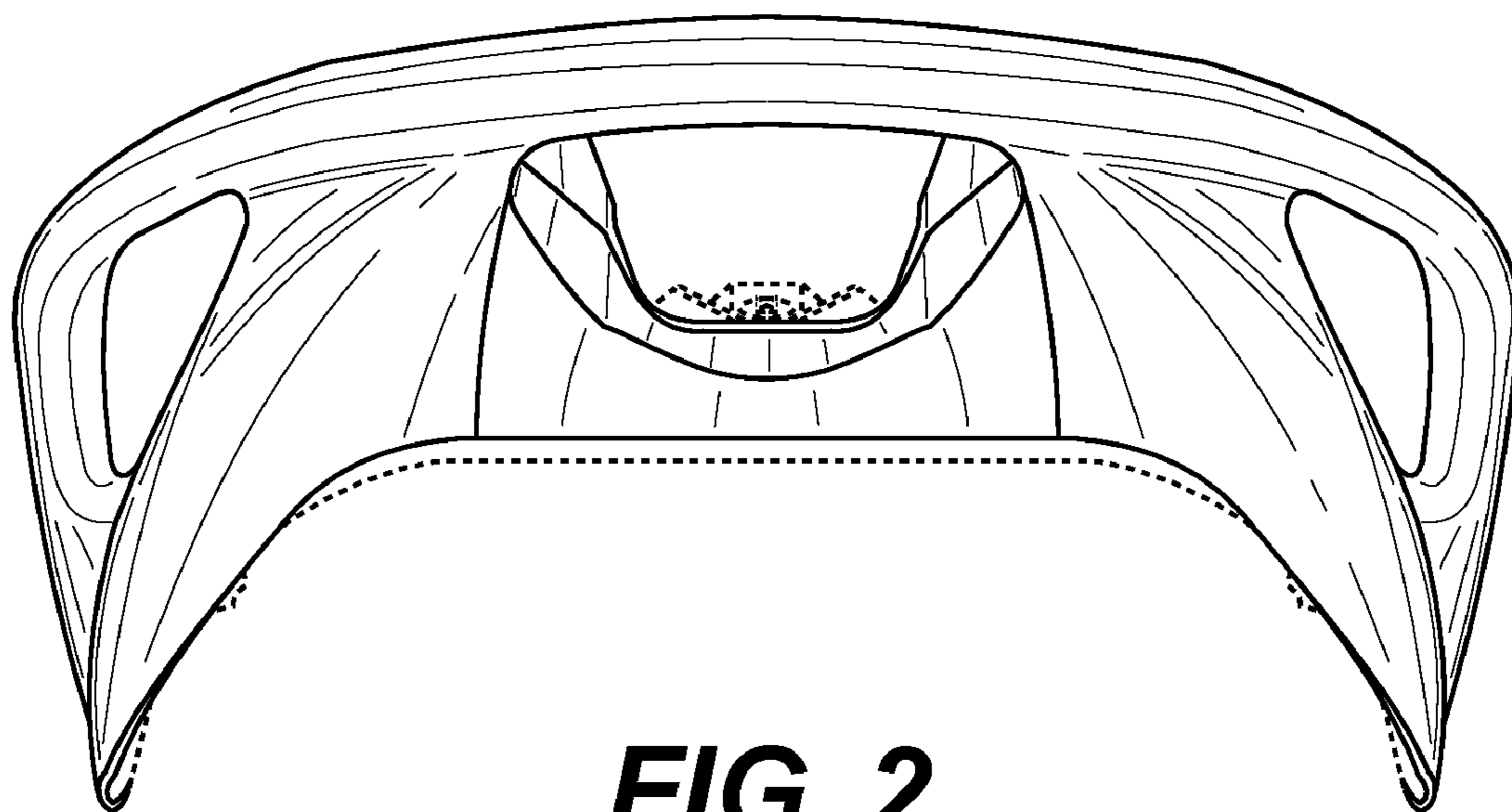

FIG. 2

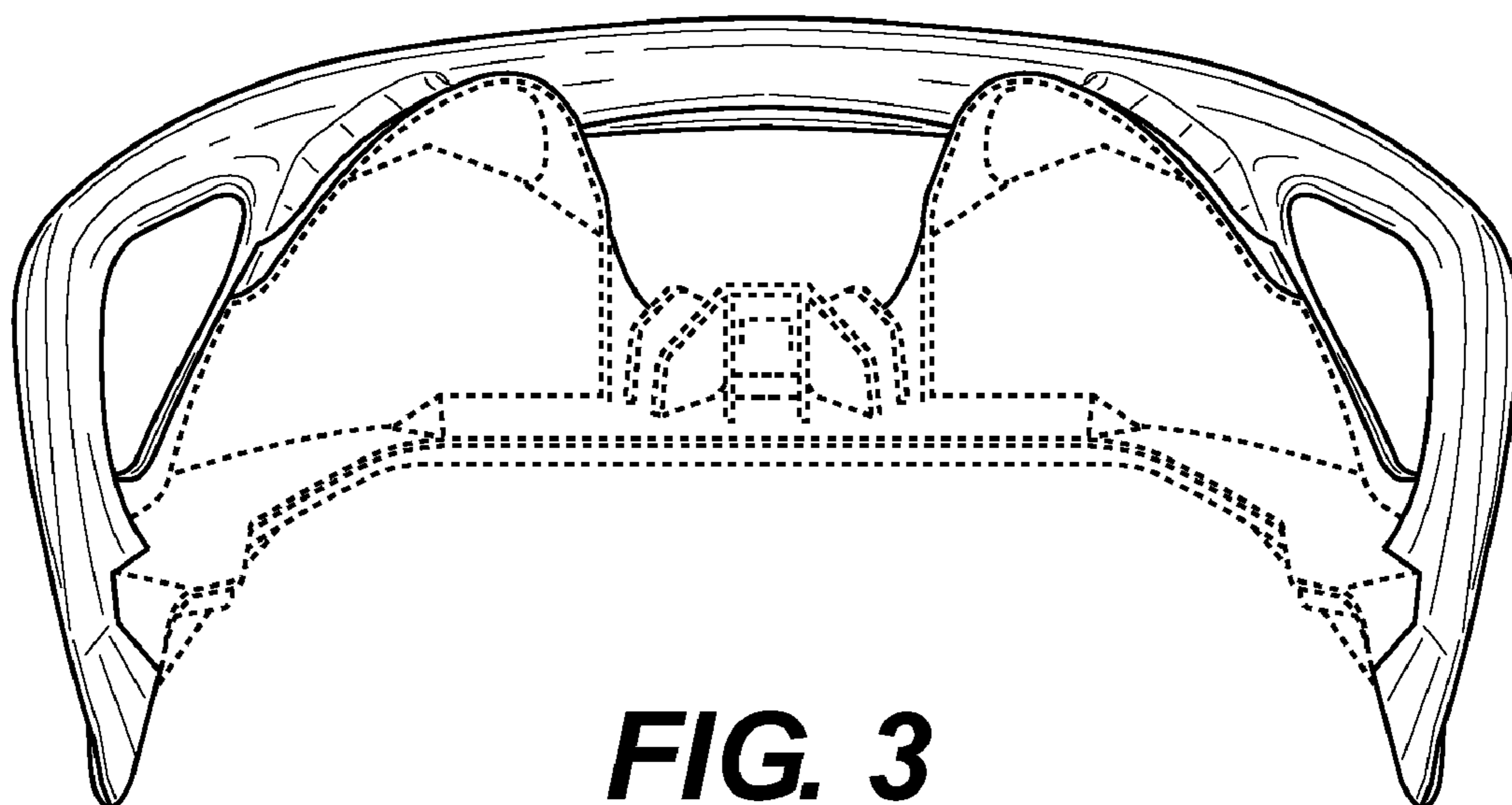

FIG. 3

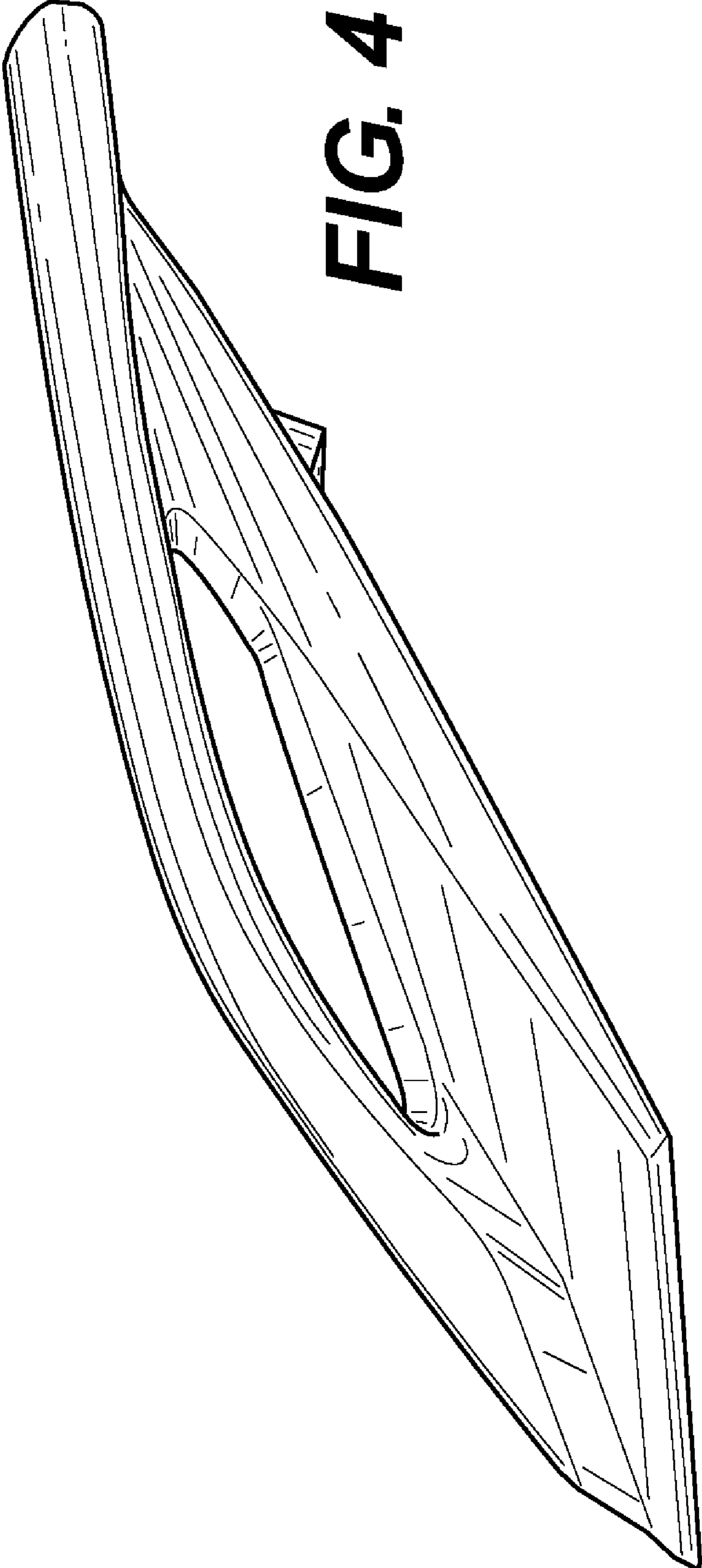

FIG. 4

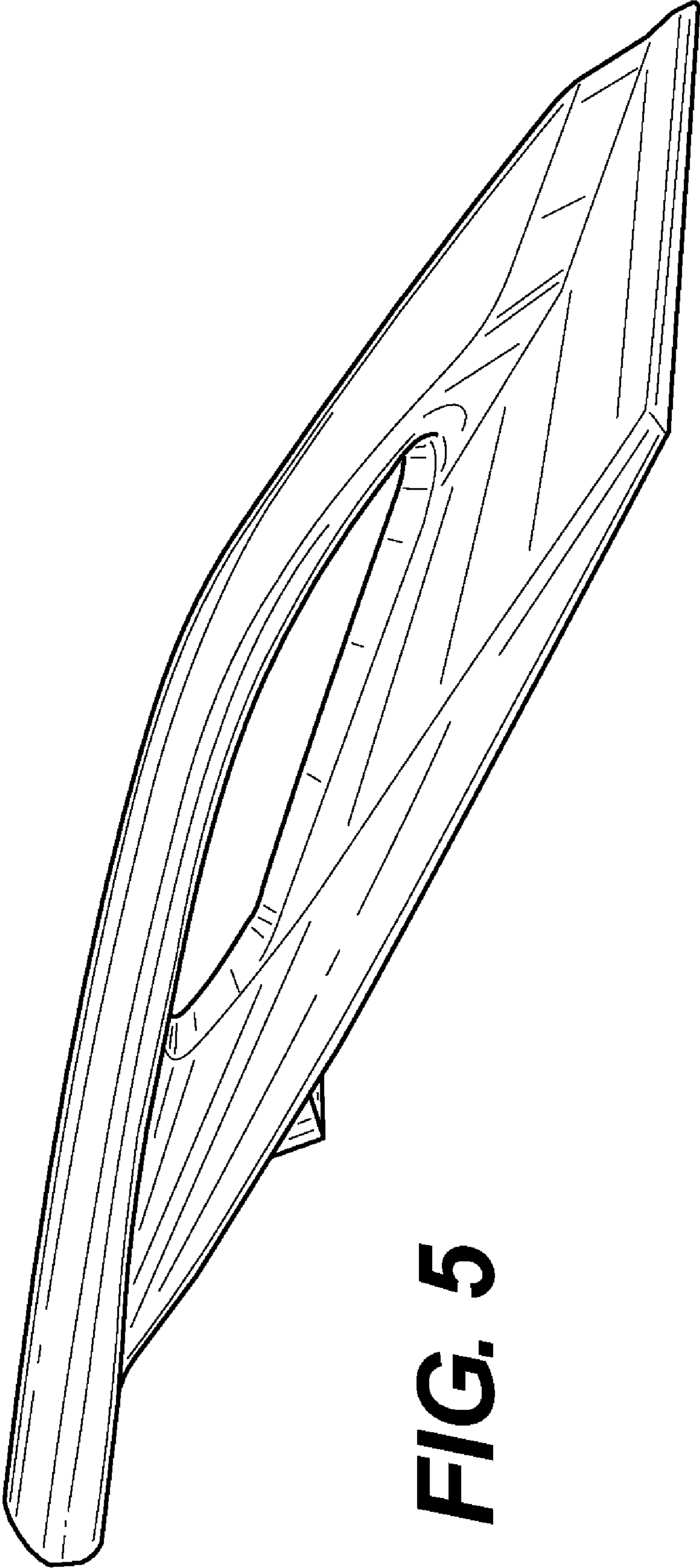

FIG. 5

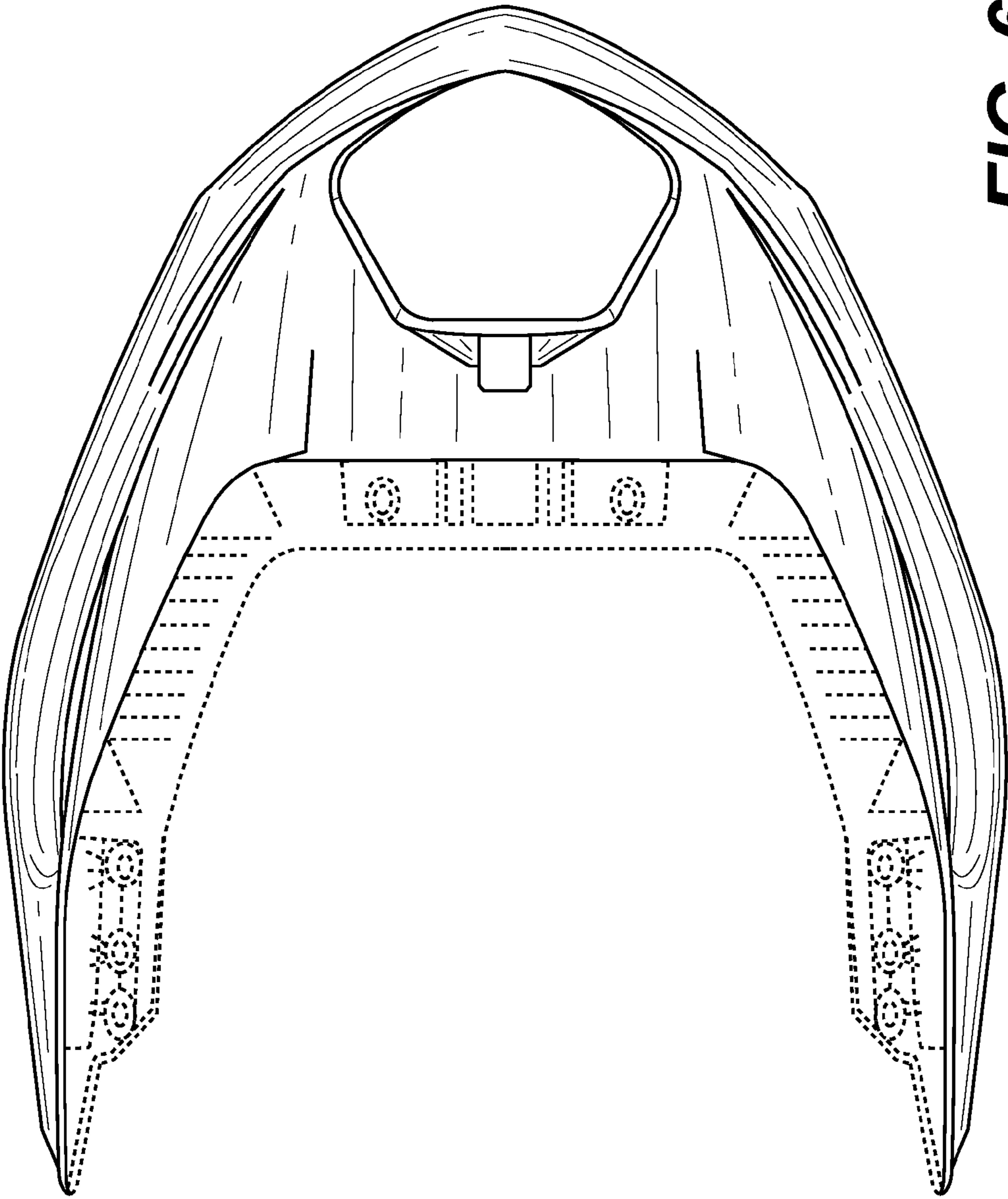

FIG. 6

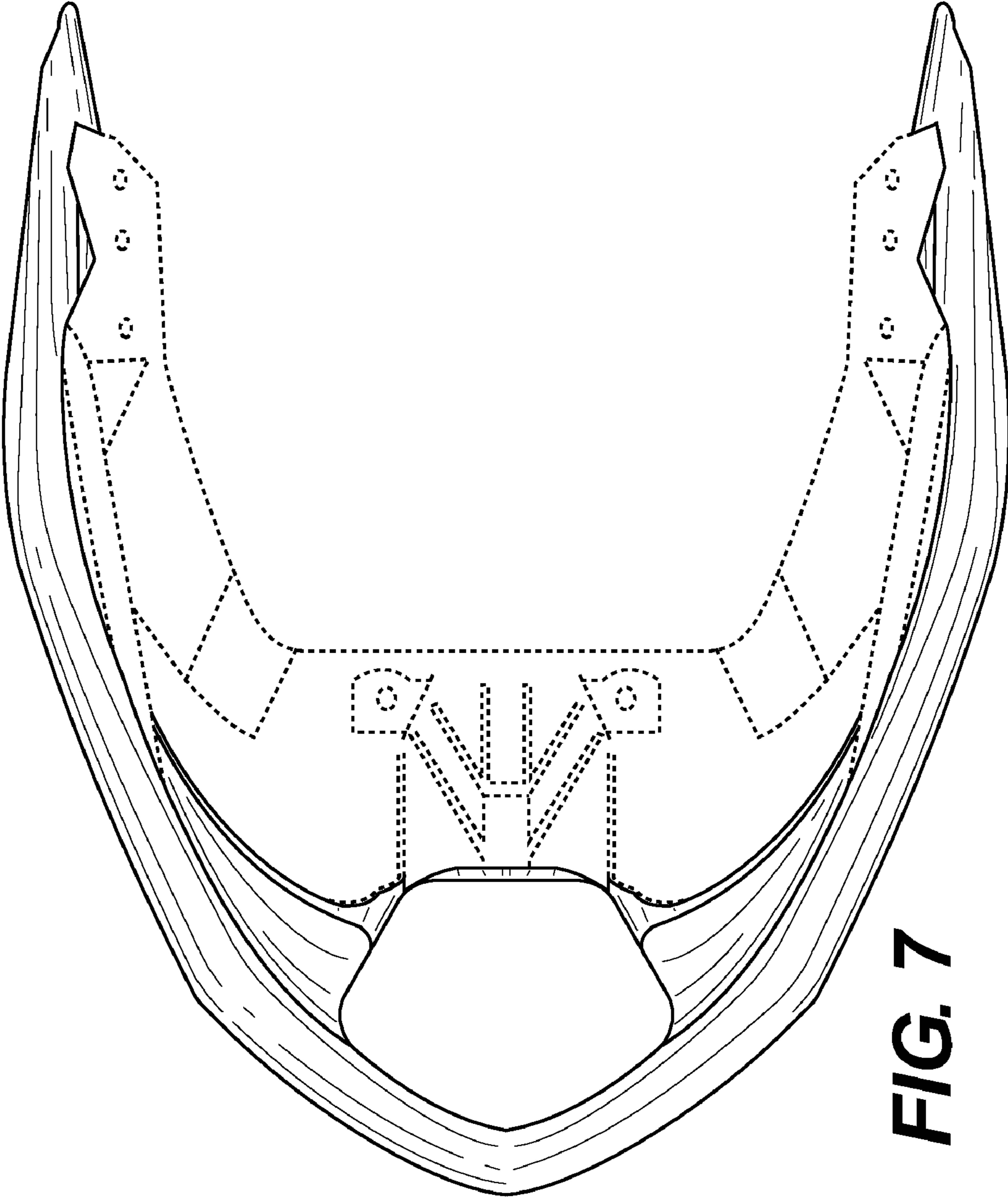

FIG. 7

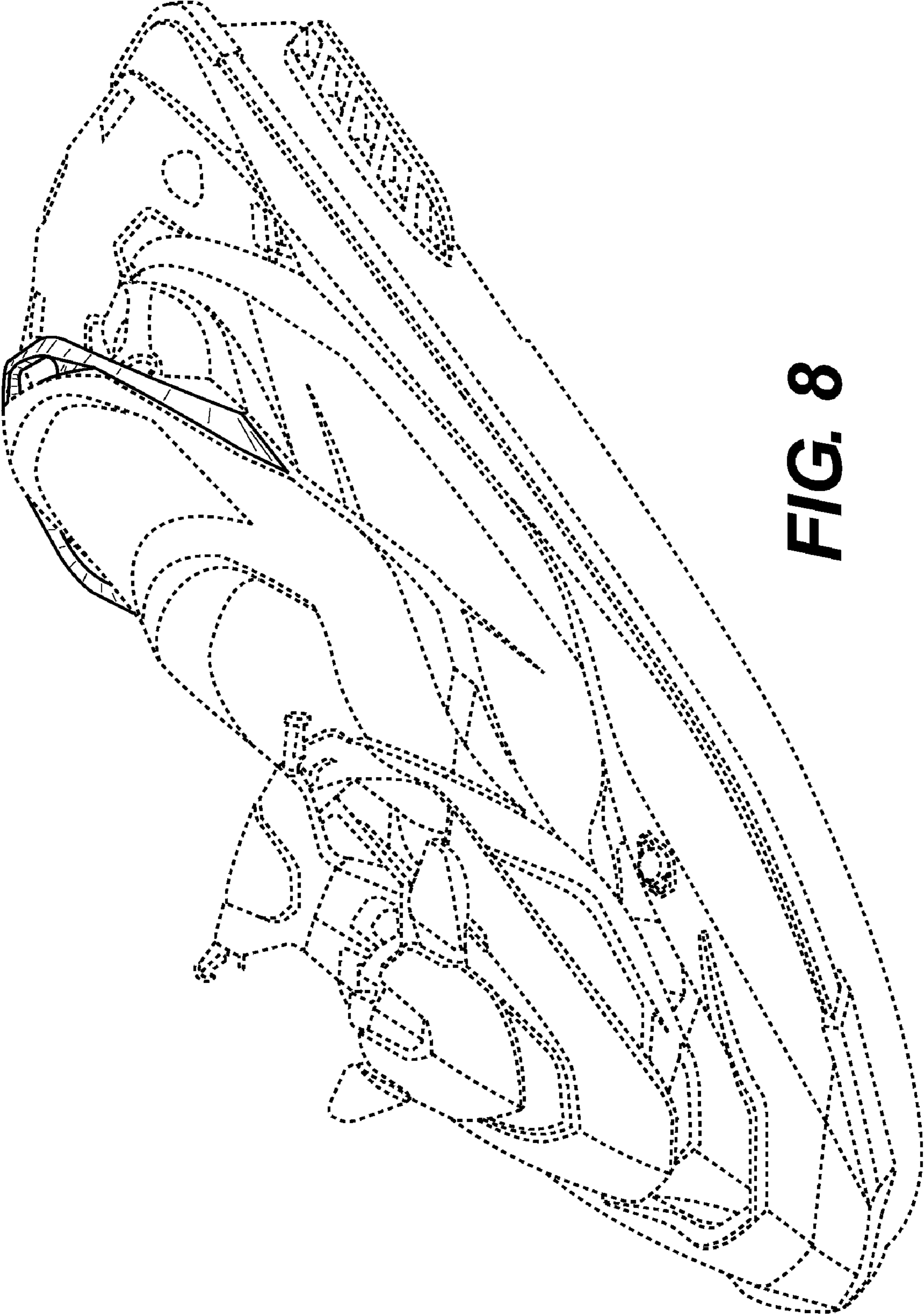

FIG. 8

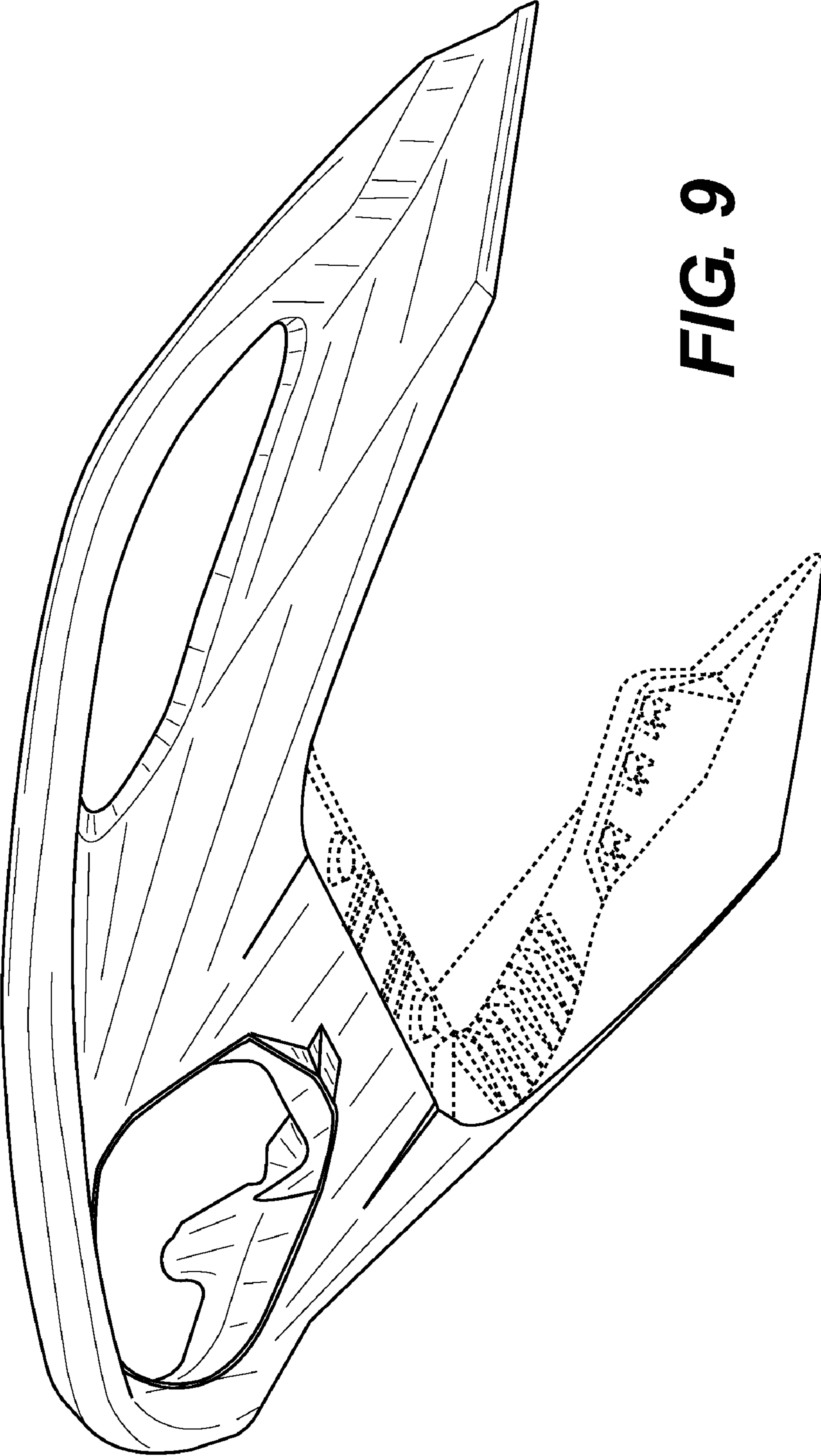

FIG. 9

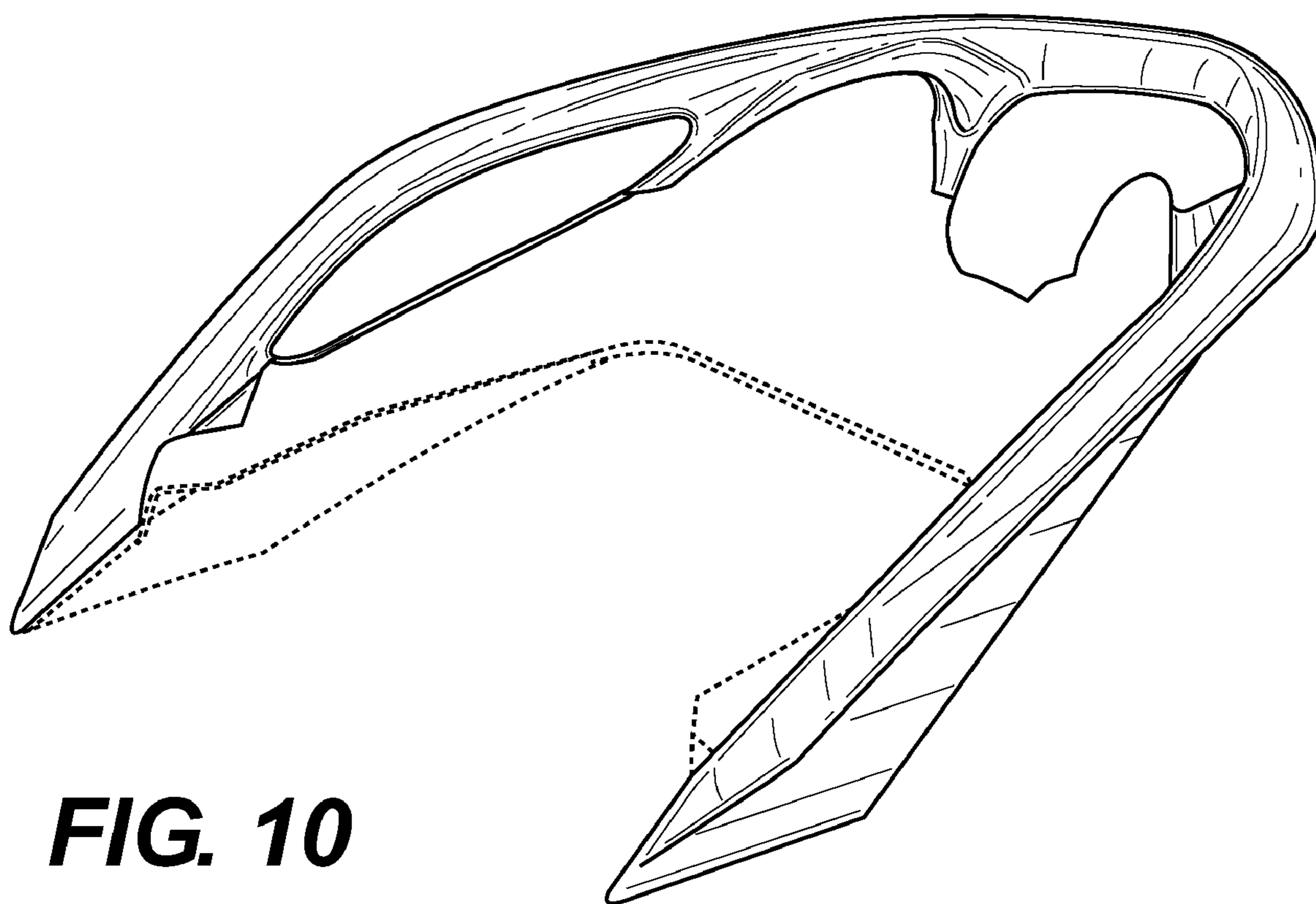

FIG. 10

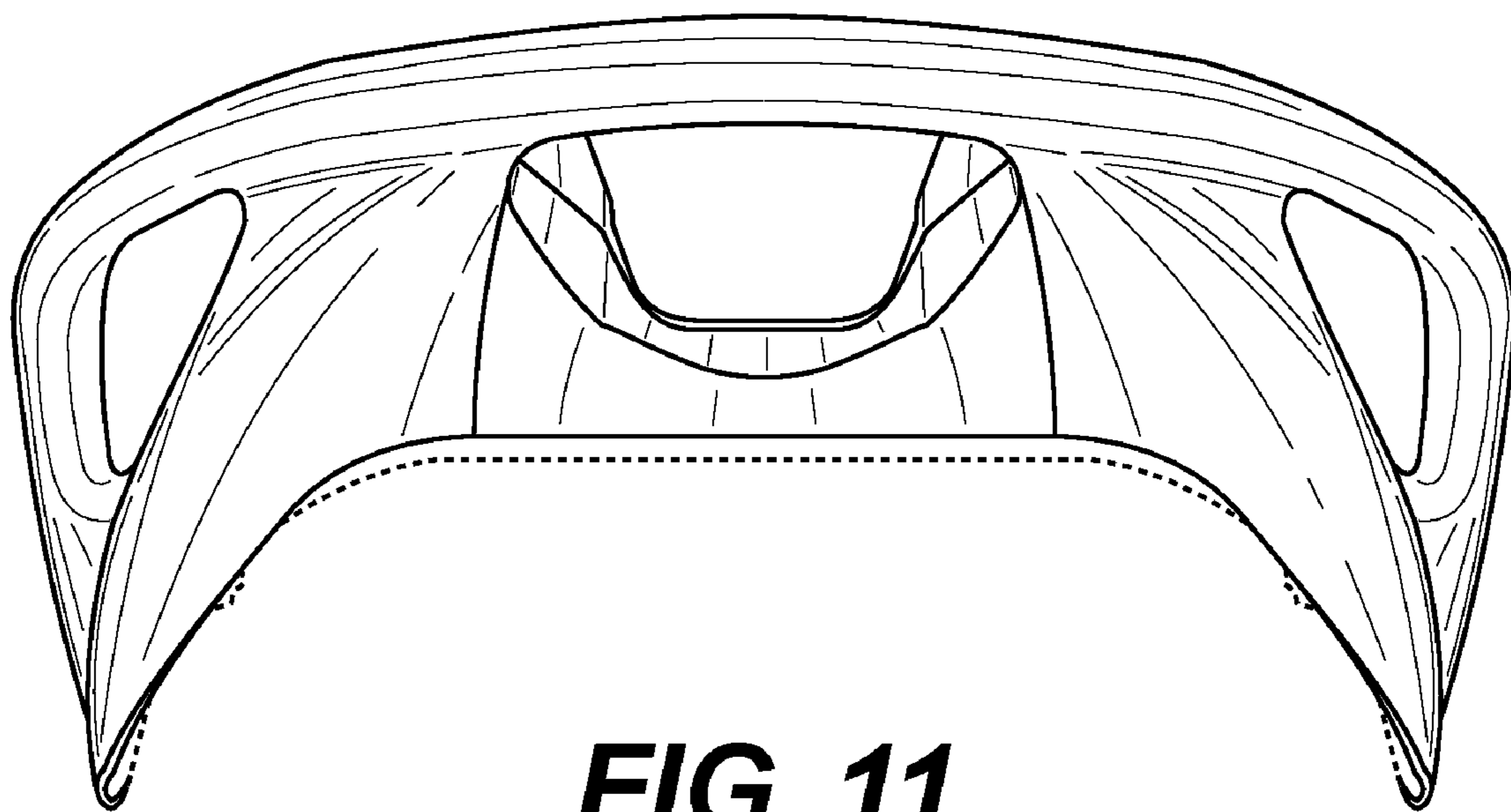

FIG. 11

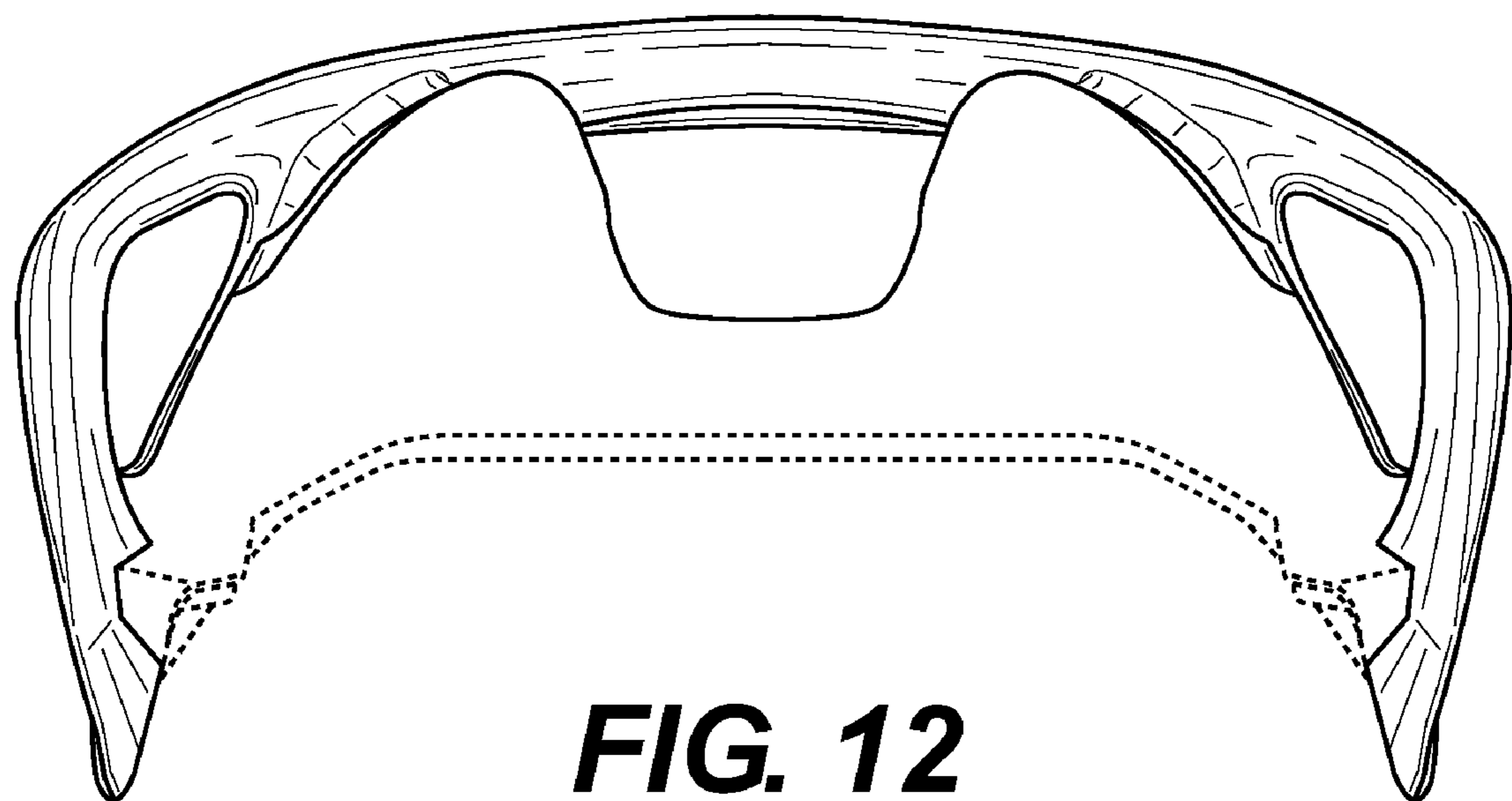

FIG. 12



FIG. 13

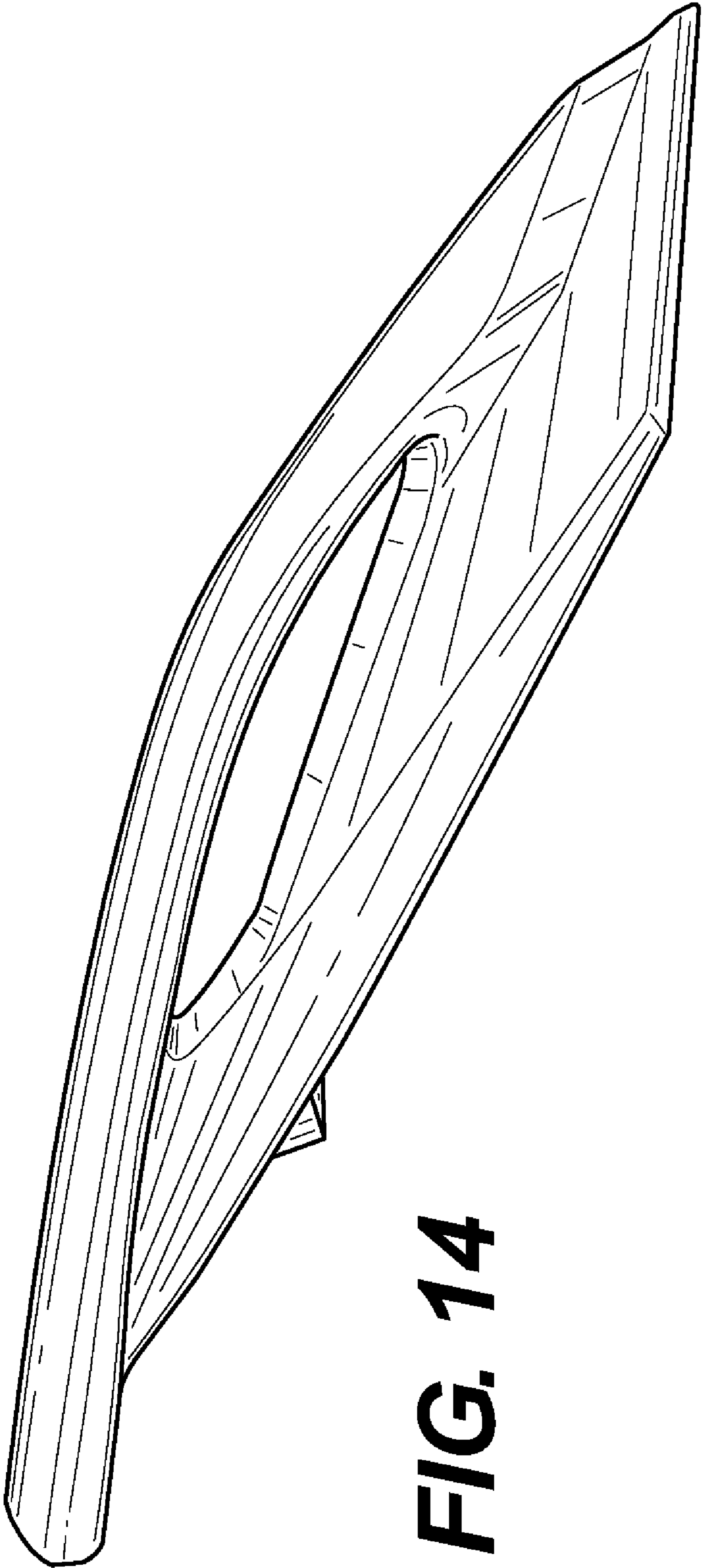

FIG. 14

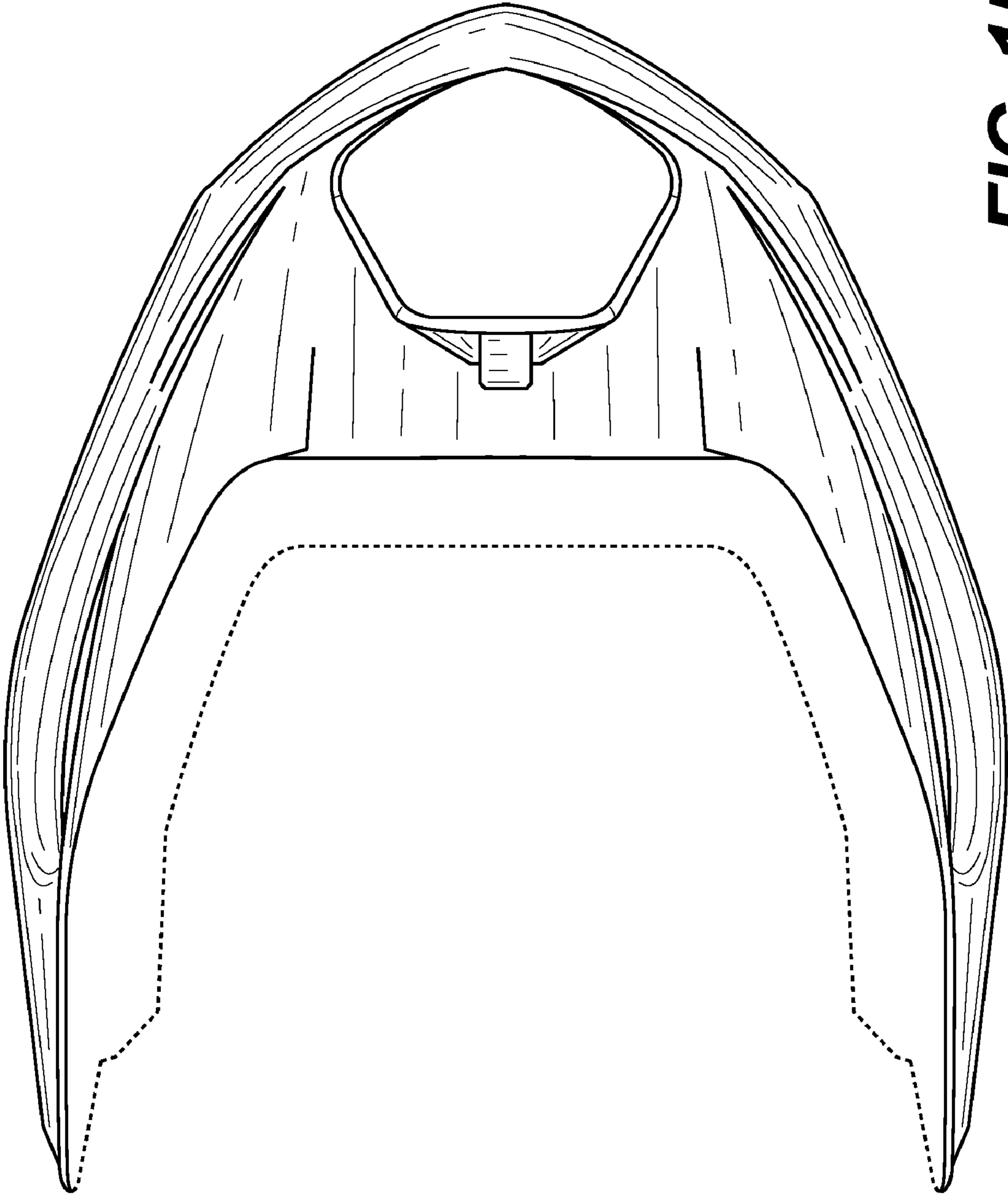

FIG. 15

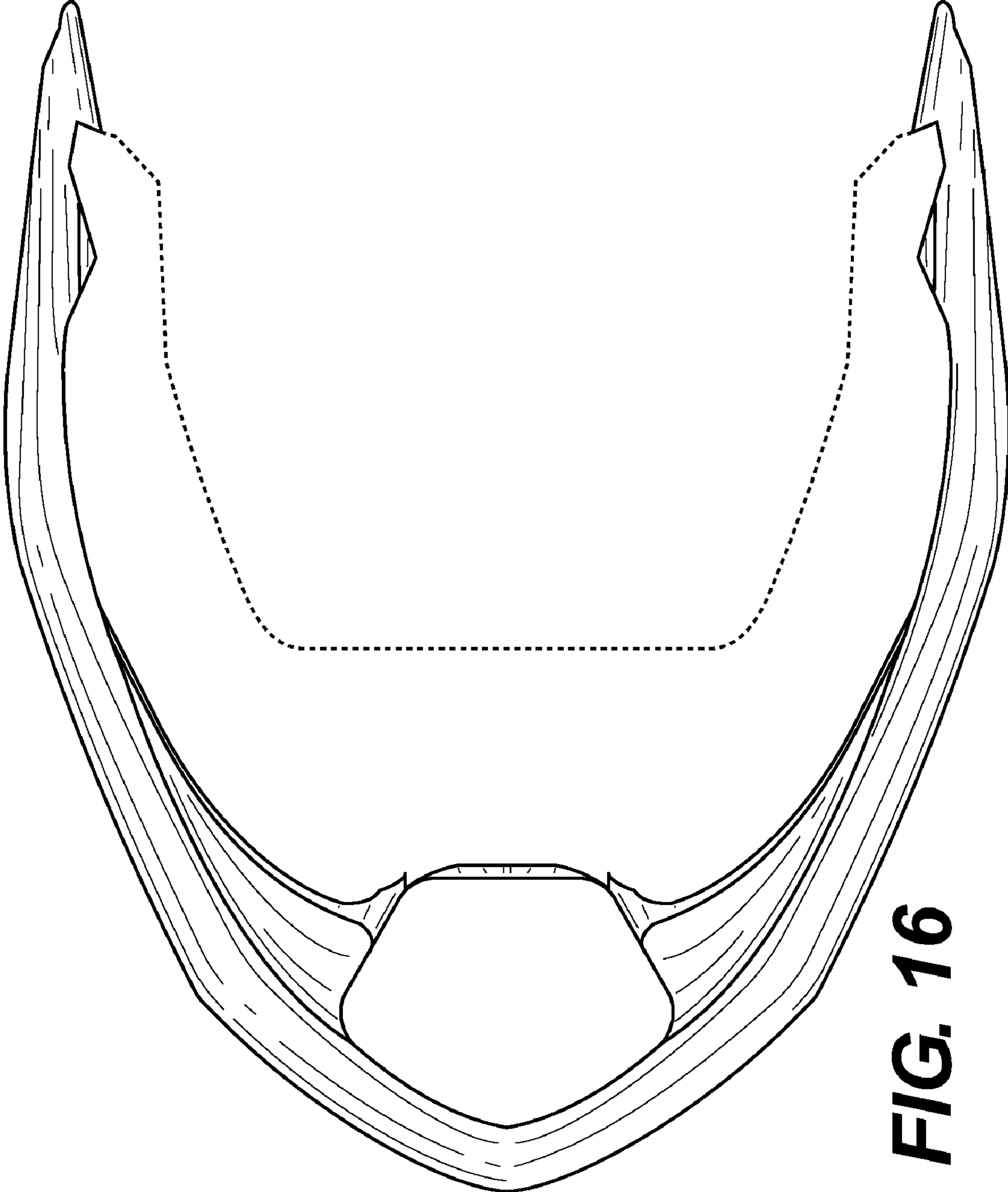

FIG. 16

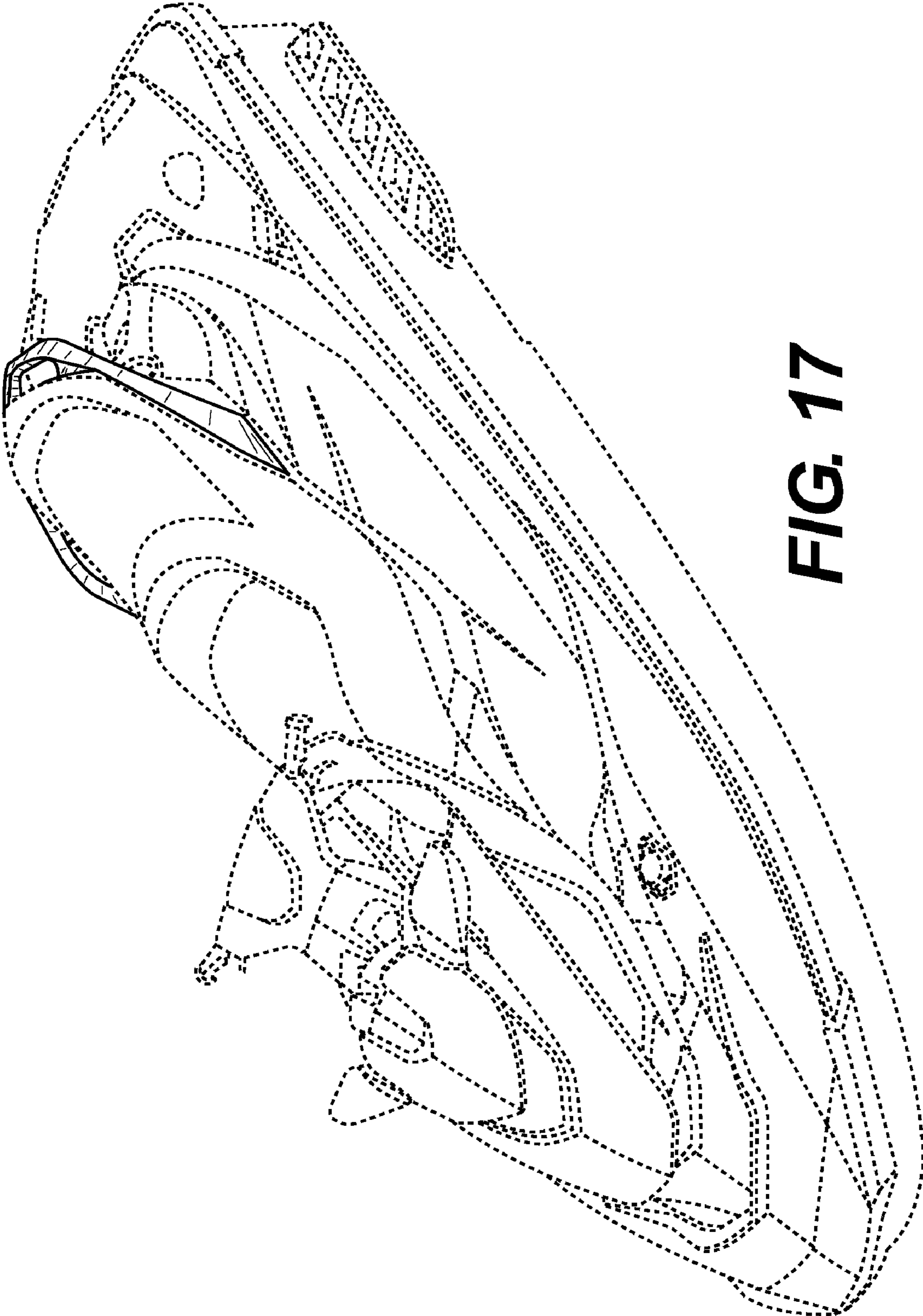

FIG. 17

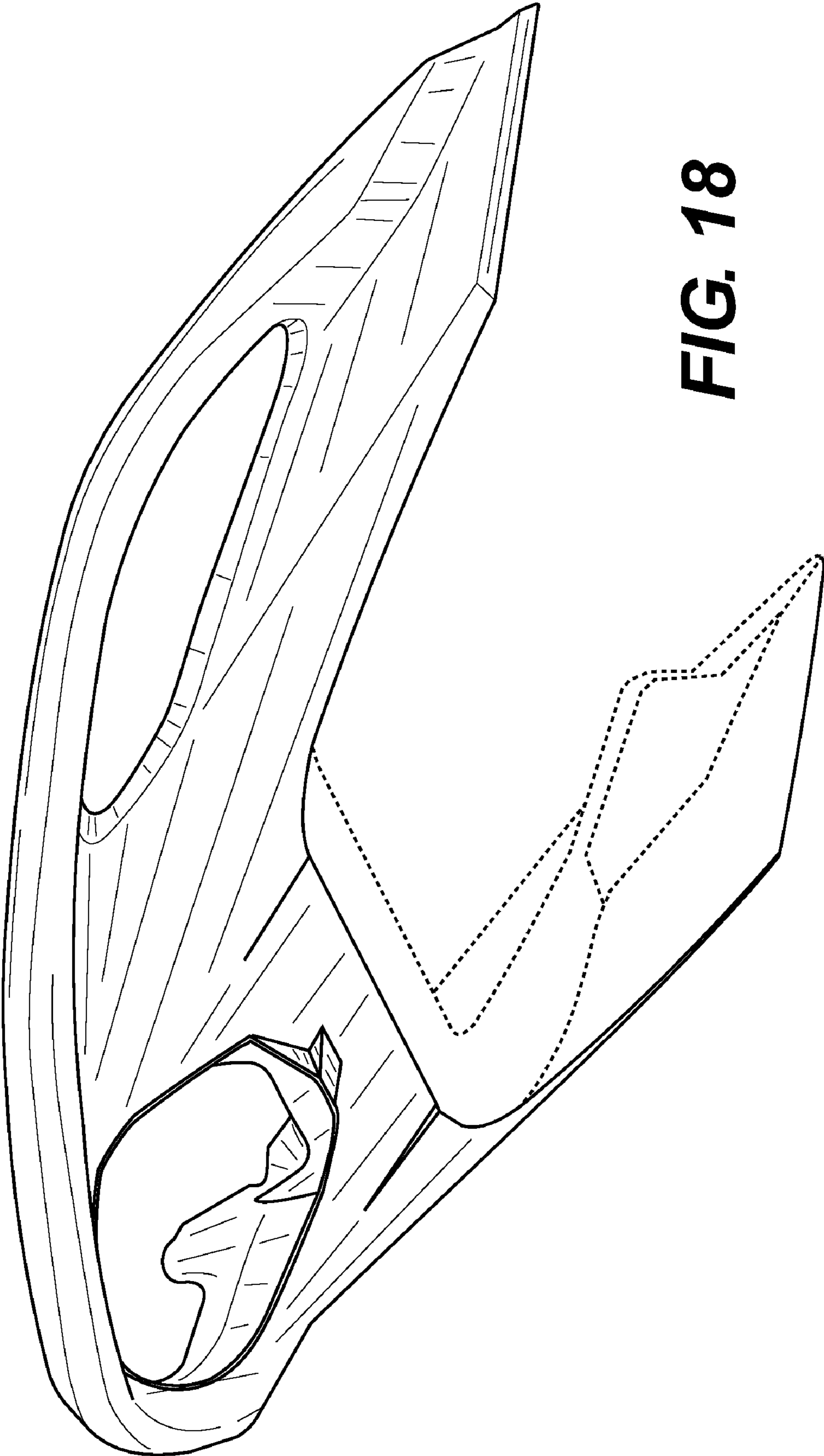

FIG. 18