



US00D630144S

(12) **United States Design Patent**  
**Chung**

(10) **Patent No.:** **US D630,144 S**  
(45) **Date of Patent:** **\*\* Jan. 4, 2011**

(54) **WHEEL**

(75) Inventor: **Suny Chung**, Anaheim, CA (US)

(73) Assignee: **Wheel Pros, LLC**, Lakewood, CO (US)

(\*\*) Term: **14 Years**

(21) Appl. No.: **29/361,339**

(22) Filed: **May 10, 2010**

(51) **LOC (9) Cl.** ..... **12-16**

(52) **U.S. Cl.** ..... **D12/209**

(58) **Field of Classification Search** ..... D12/204-213;  
301/37.101, 64.101, 65, 64.201

See application file for complete search history.

(56) **References Cited**

U.S. PATENT DOCUMENTS

D292,390 S \* 10/1987 Ruzzin ..... D12/211

(Continued)

*Primary Examiner*—Stacia Cadmus

(74) *Attorney, Agent, or Firm*—Garcia-Zamor IP Law; Ruy M. Garcia-Zamor

(57) **CLAIM**

The ornamental design for a wheel, as shown and described.

**DESCRIPTION**

FIG. 1 is a perspective view of a wheel according to a first preferred embodiment of my new design;

FIG. 2 is a front elevational view of the wheel of FIG. 1;

FIG. 3 is a top plan view of the wheel of FIG. 1;

FIG. 4 is a bottom plan view of the wheel of FIG. 1;

FIG. 5 is a left side elevational view of the wheel of FIG. 1;

FIG. 6 is a right side elevational view of the wheel of FIG. 1;

FIG. 7 is a perspective view of a wheel according to a second preferred embodiment of my new design;

FIG. 8 is a front elevational view of the wheel of FIG. 7;

FIG. 9 is a top plan view of the wheel of FIG. 7;

FIG. 10 is a bottom plan view of the wheel of FIG. 7;

FIG. 11 is a left side elevational view of the wheel of FIG. 7;

FIG. 12 is a right side elevational view of the wheel of FIG. 7;

FIG. 13 is a rear elevational view of the wheel of FIG. 7;

FIG. 14 is a perspective view of a wheel according to a third preferred embodiment of my new design;

FIG. 15 is a front elevational view of the wheel of FIG. 14;

FIG. 16 is a top plan view of the wheel of FIG. 14;

FIG. 17 is a bottom plan view of the wheel of FIG. 14;

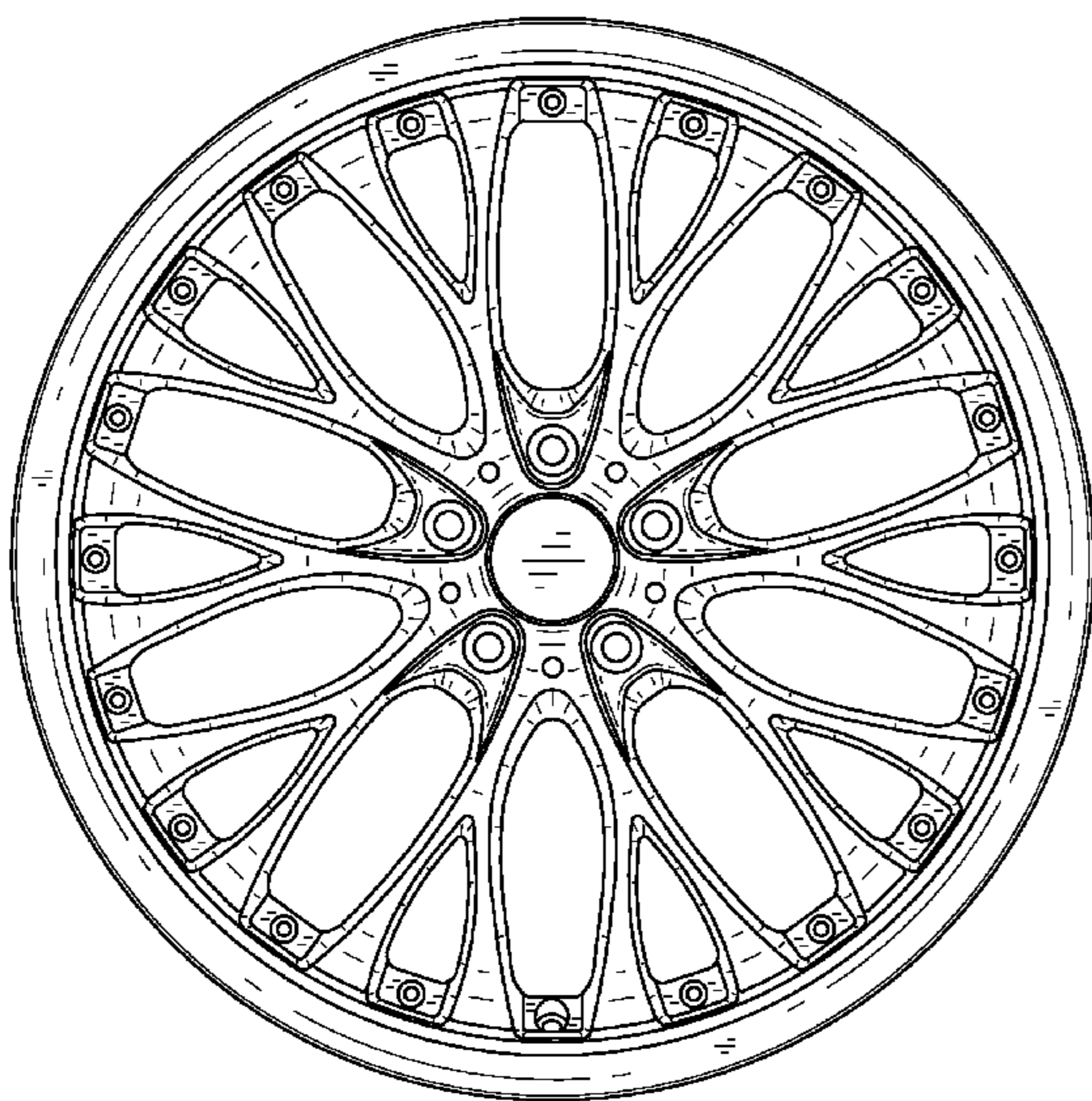
FIG. 18 is a left side elevational view of the wheel of FIG. 14;

FIG. 19 is a right side elevational view of the wheel of FIG. 14; and,

FIG. 20 is a rear elevational view of the wheel of FIG. 14.

The broken lines in FIGS. 1-20 represent environment and are for illustrative purposes only and do not constitute part of the claimed design.

**1 Claim, 14 Drawing Sheets**



# US D630,144 S

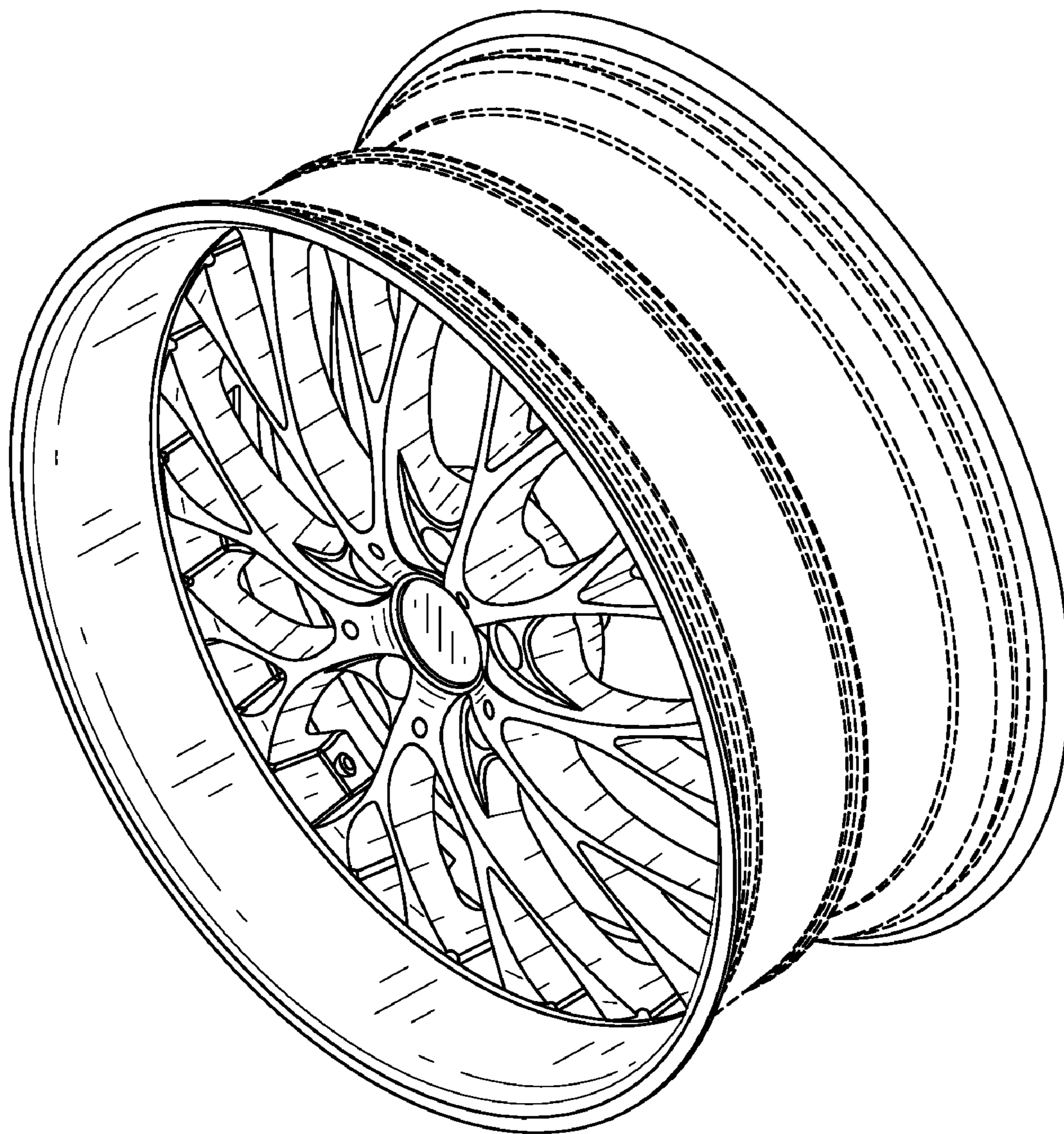
Page 2

---

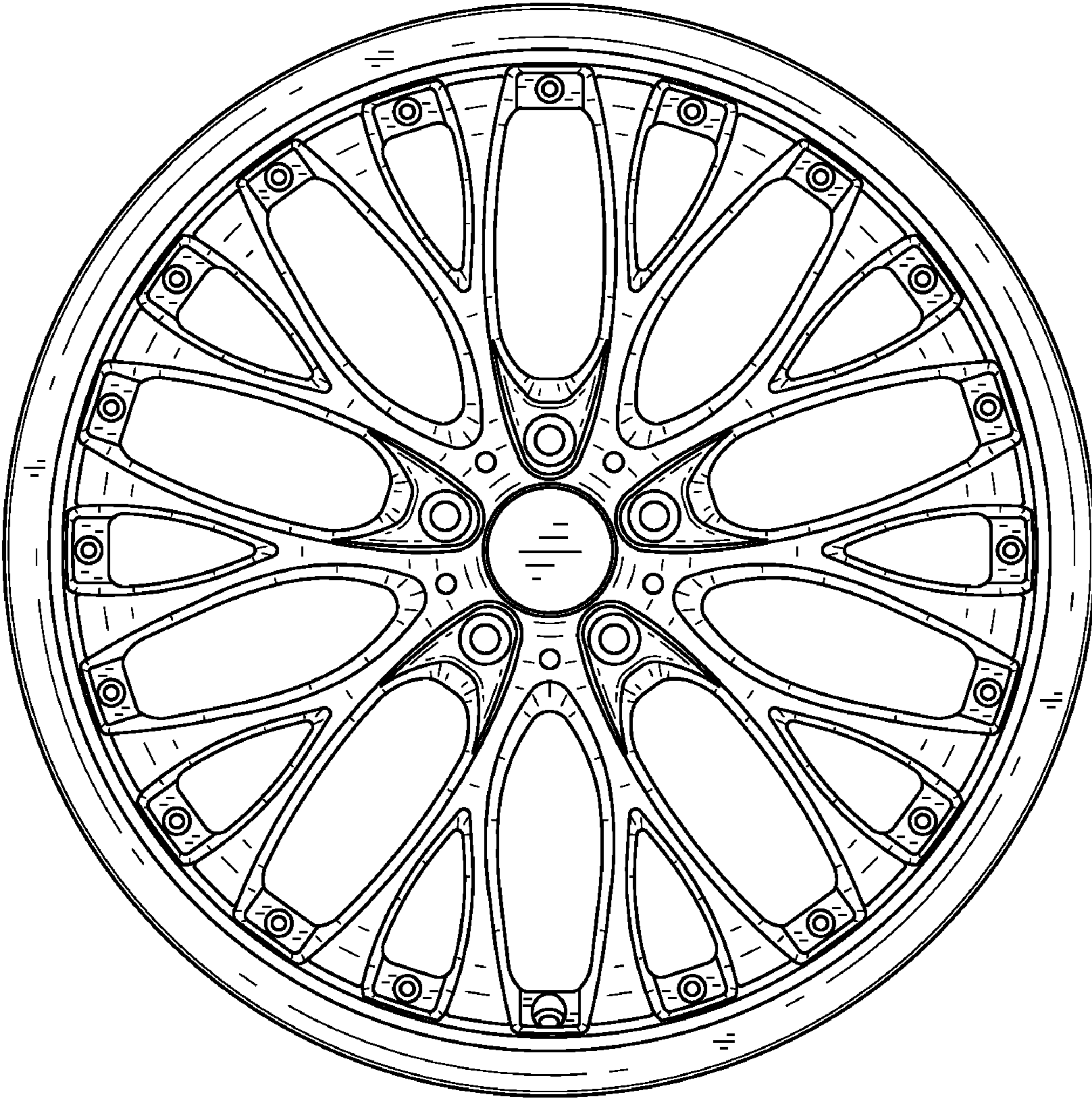
## U.S. PATENT DOCUMENTS

D323,806 S	*	2/1992	Stewart	.....	D12/209				
D437,577 S	*	2/2001	Iacovelli	.....	D12/209				
D449,810 S	*	10/2001	Hussaini et al.	.....	D12/209				
D504,379 S	*	4/2005	Kern	.....	D12/209				
D531,949 S	*	11/2006	Arora	.....	D12/209				
D535,008 S	*	1/2007	Wu	.....	D12/209				
D539,721 S	*	4/2007	Ettensberger	.....	D12/209				
D550,138 S	*	9/2007	Walbey, Jr.	.....	D12/209				
D579,846 S	*	11/2008	Chung	.....	D12/209				
D612,787 S	*	3/2010	Juergens et al.	.....	D12/209				
D613,227 S	*	4/2010	Mueller-Stolz	.....	D12/209				
D618,154 S	*	6/2010	Zhao	.....	D12/209				

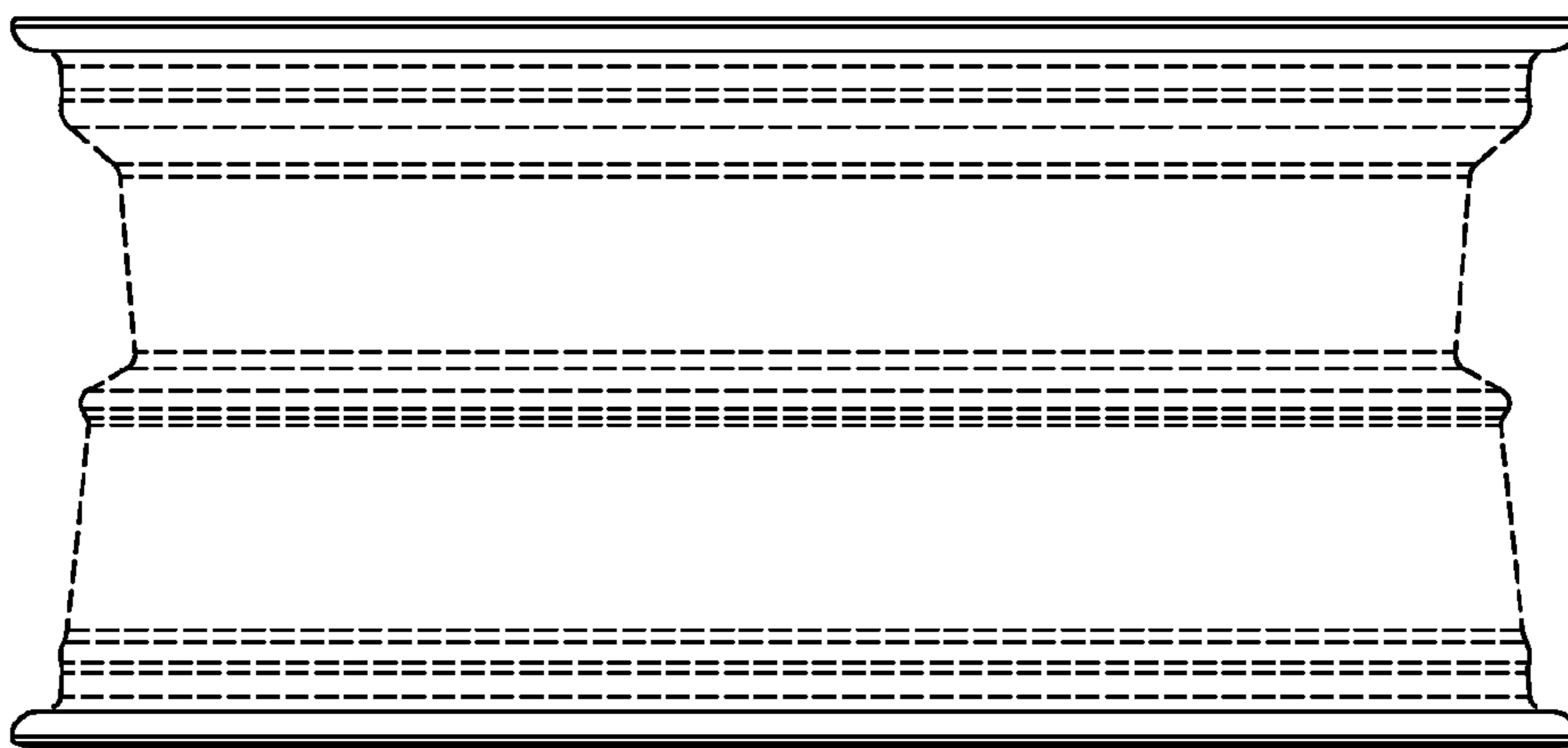
\* cited by examiner



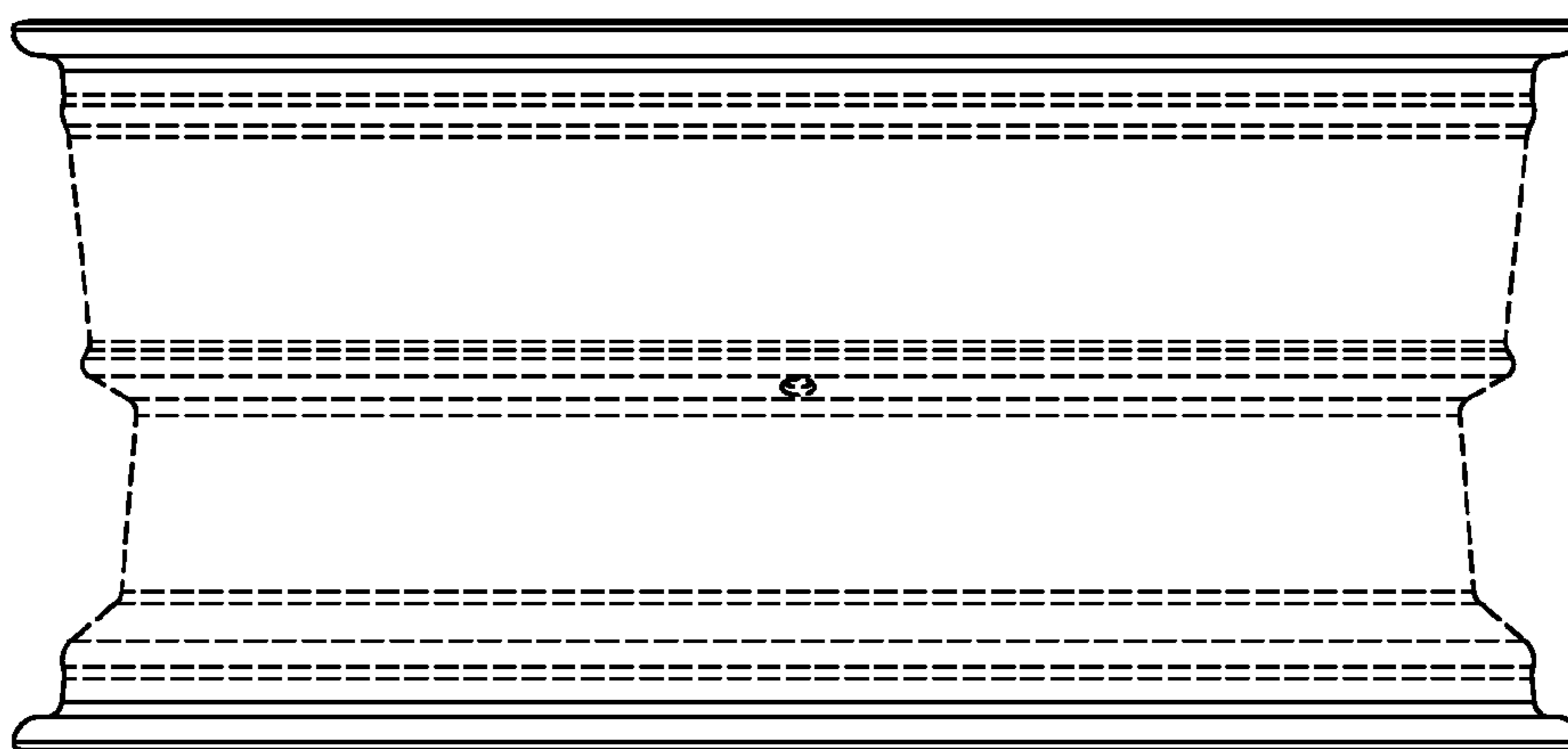
*Fig. 1*



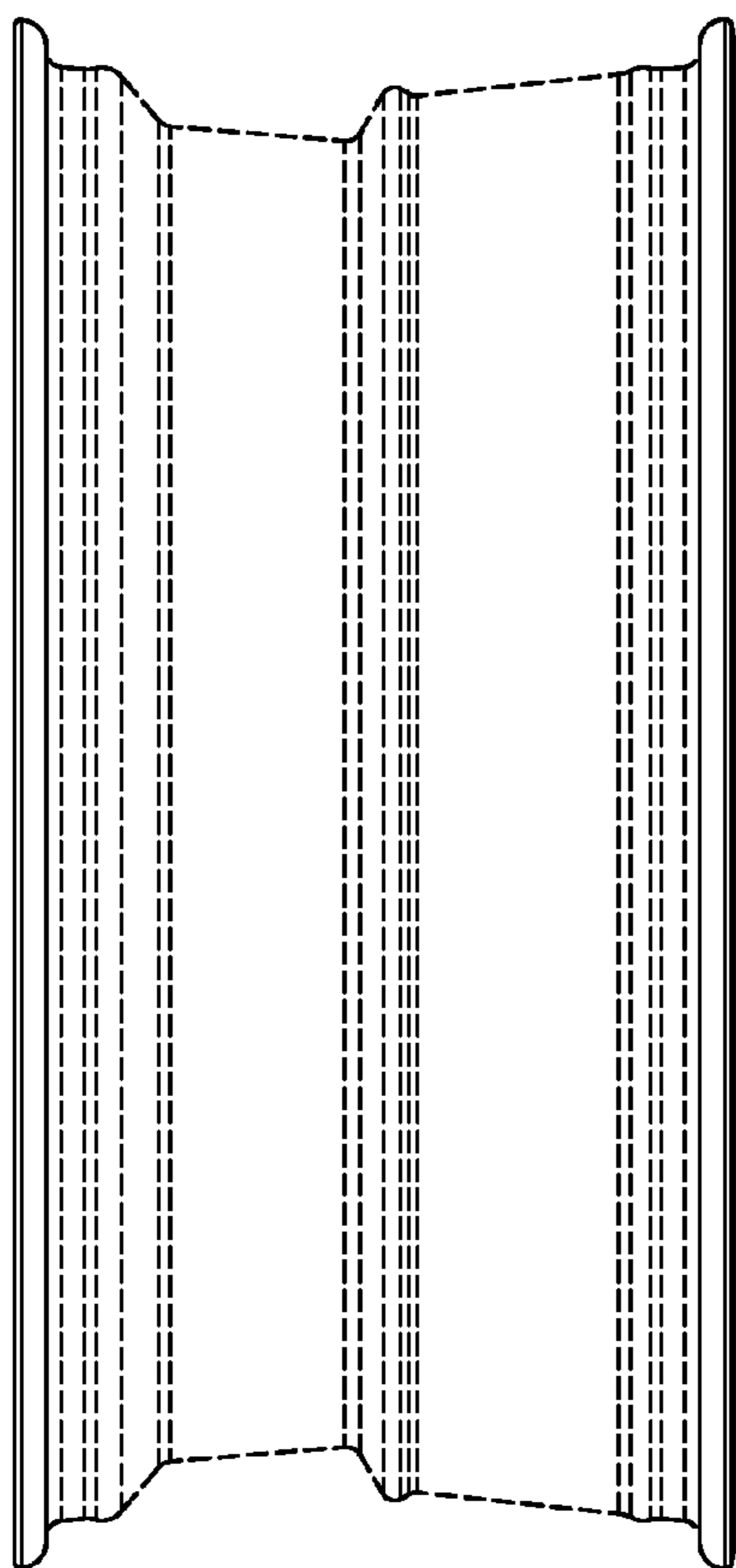
*Fig. 2*



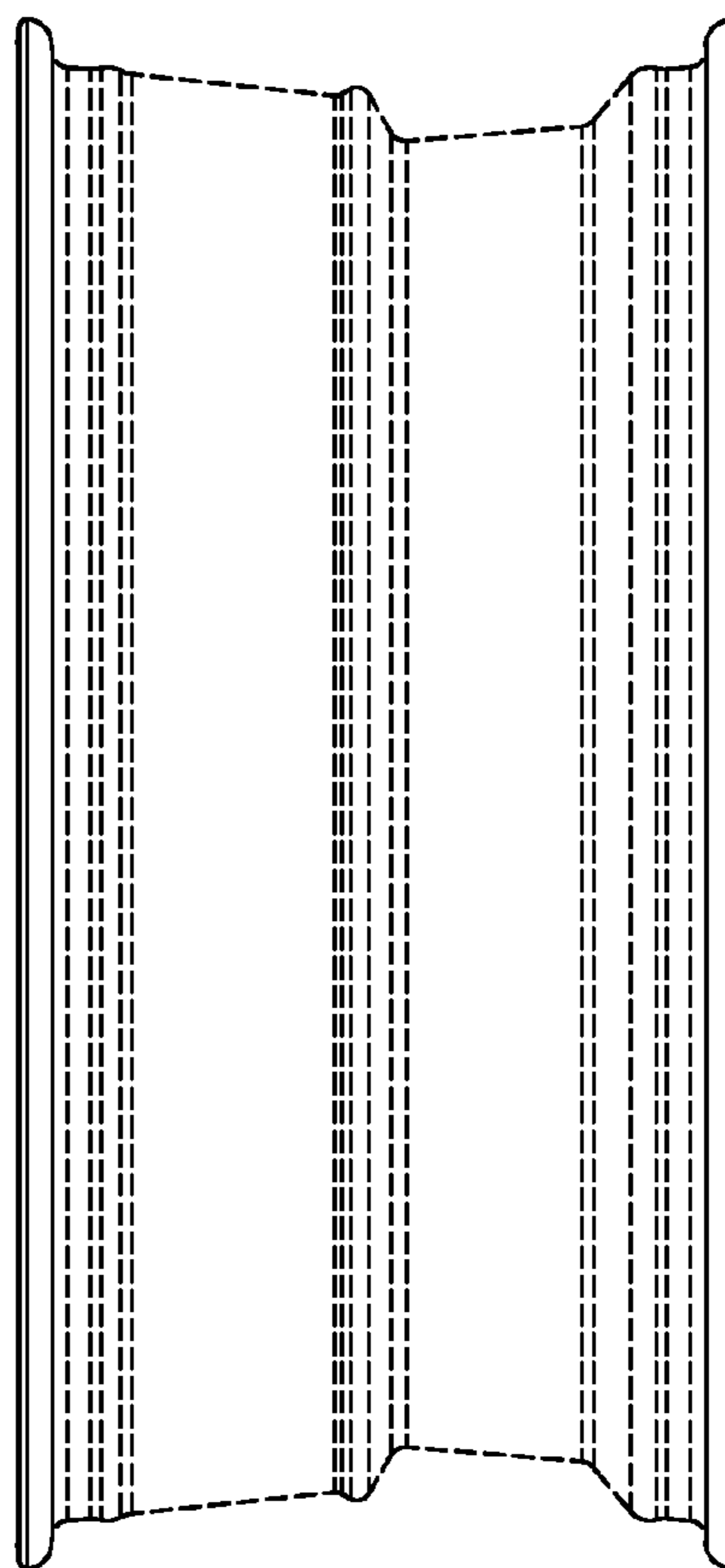
*Fig. 3*



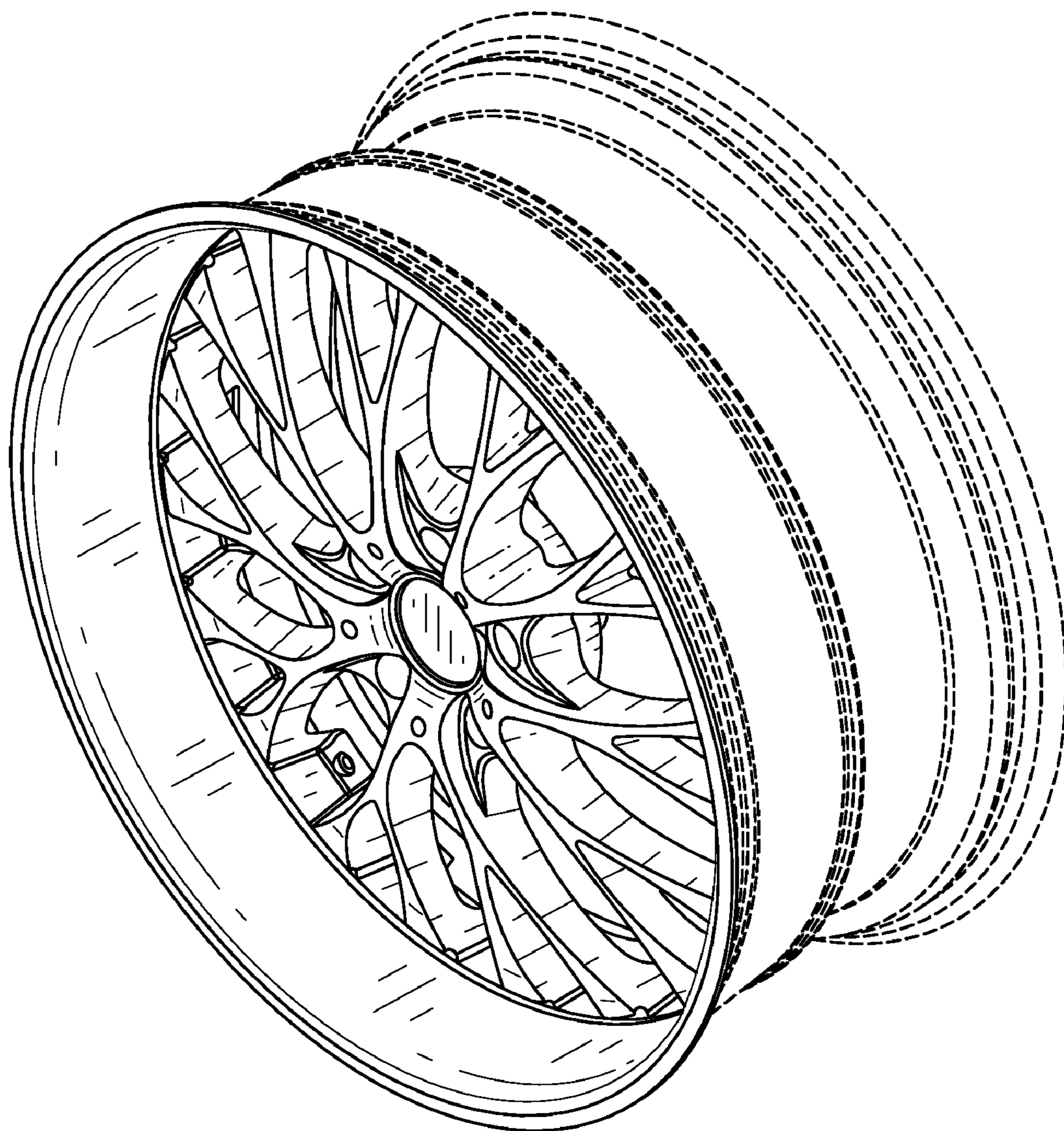
*Fig. 4*



*Fig. 5*

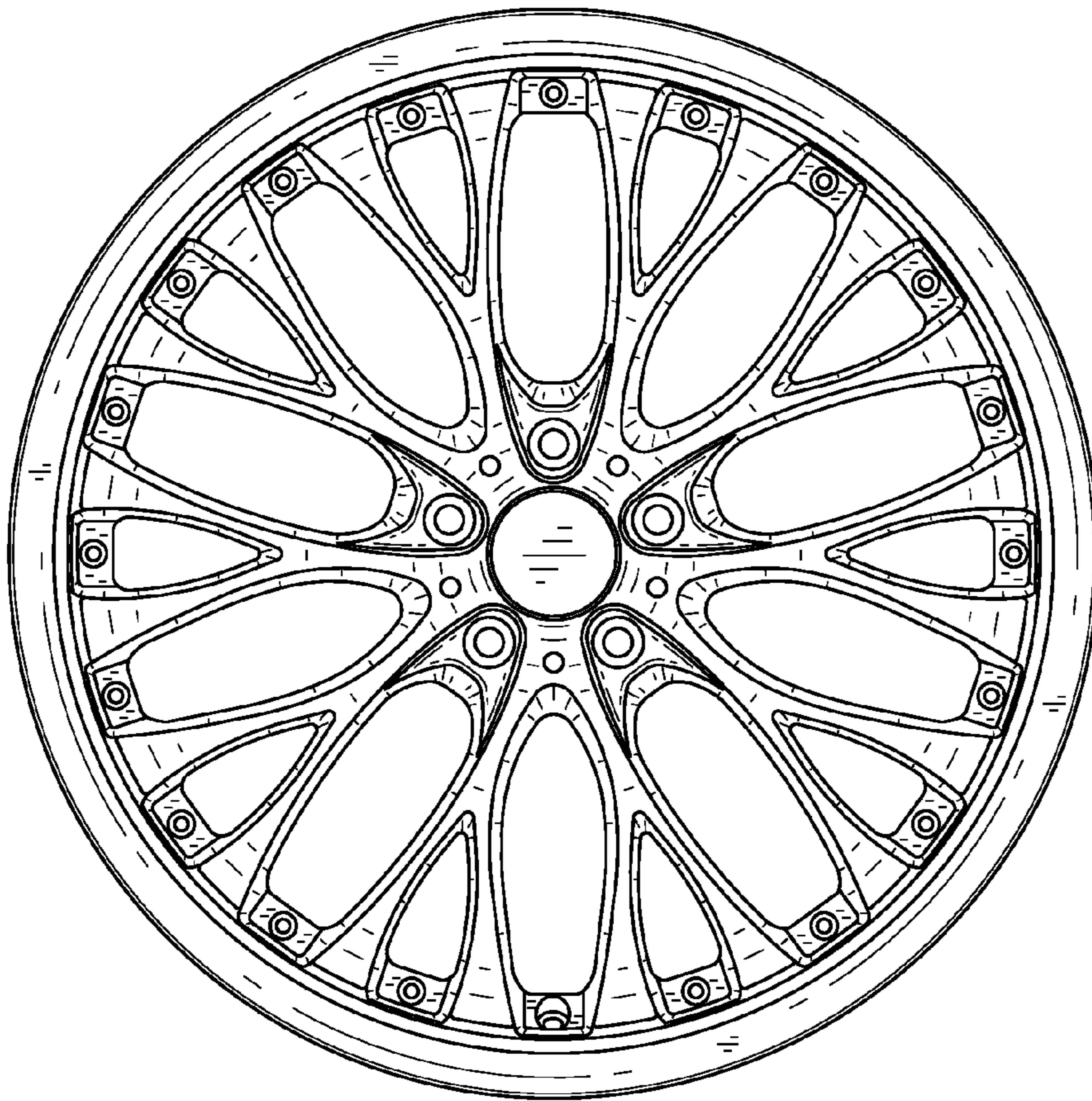


*Fig. 6*



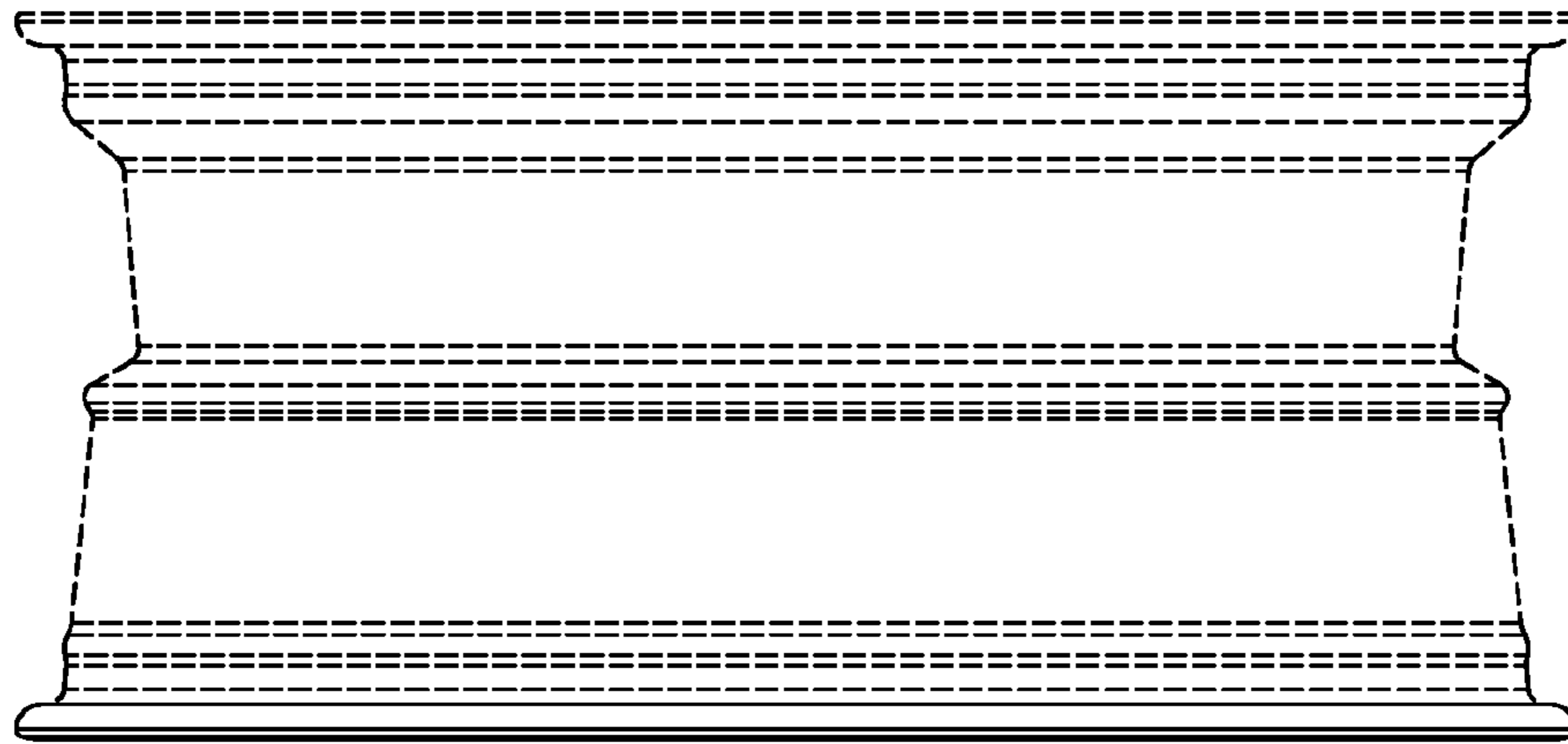
*Fig. 7*

*Fig. 8*

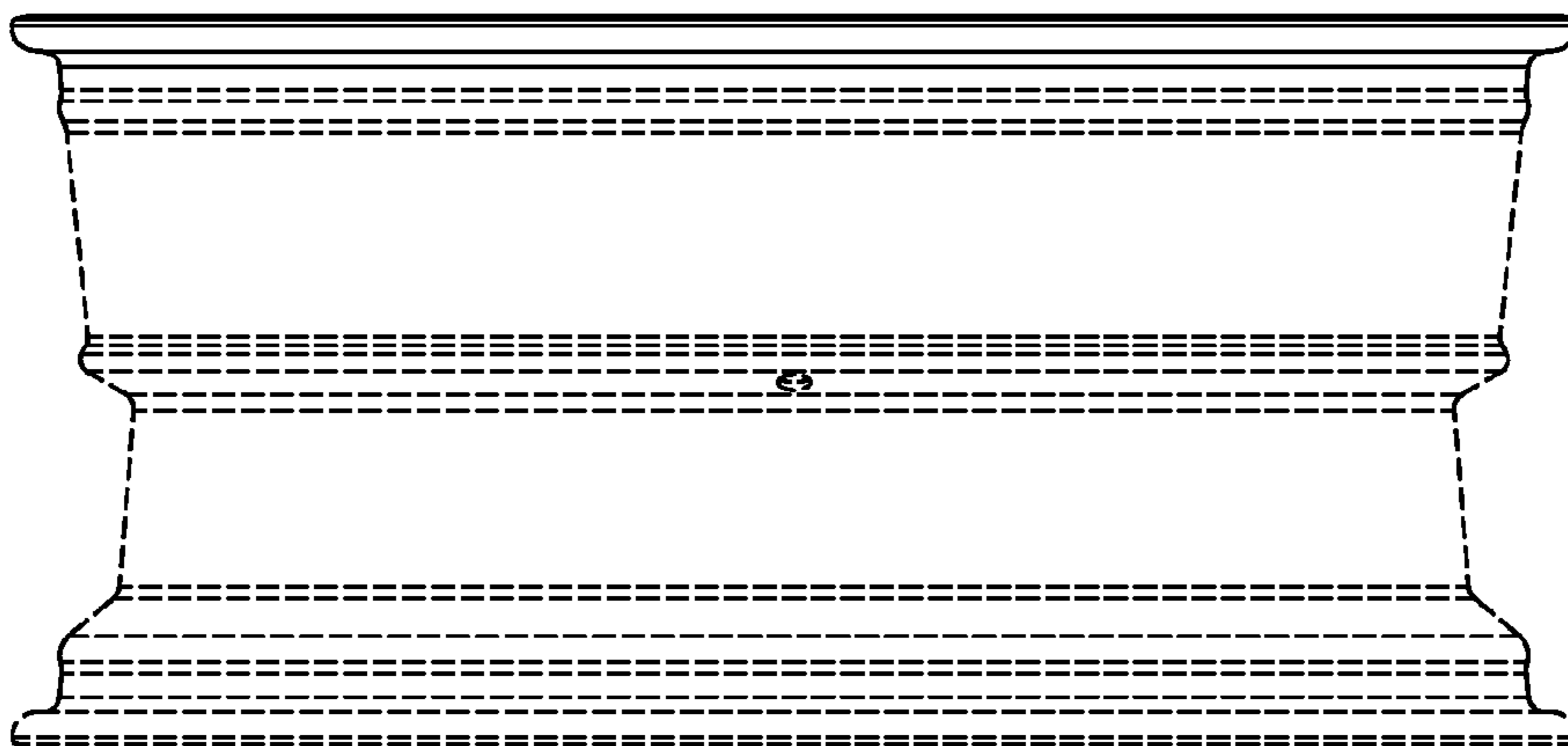




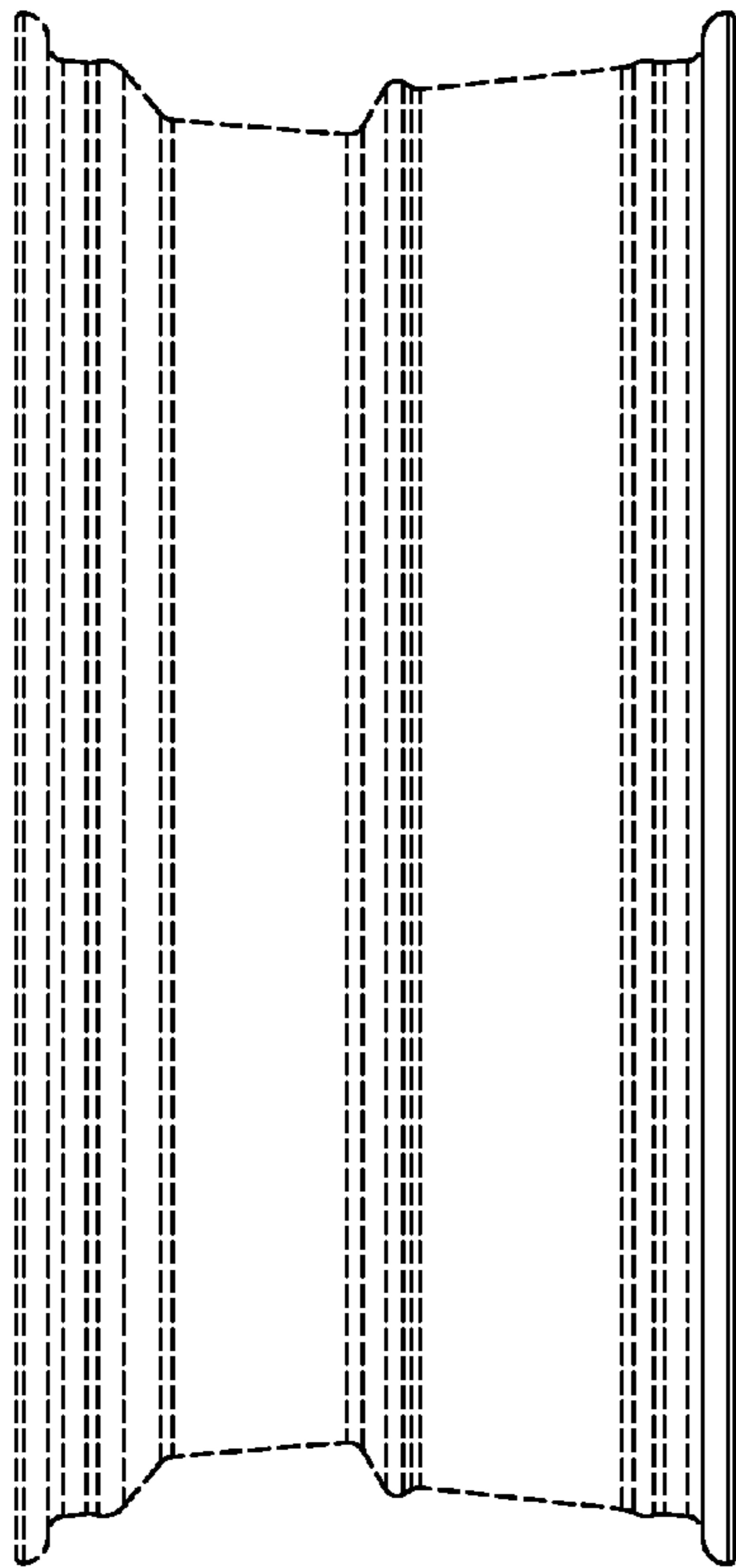
*Fig. 9*



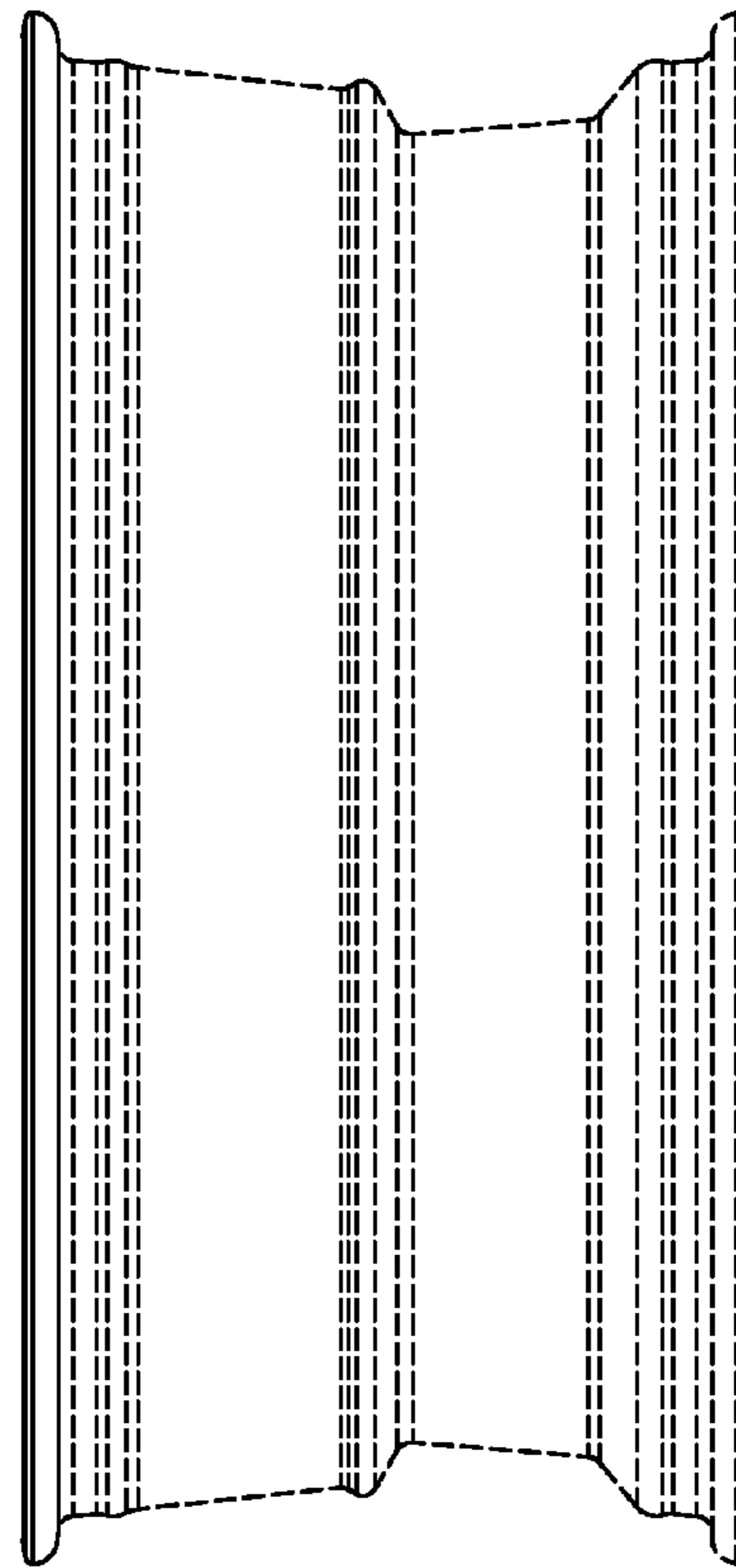
*Fig. 10*



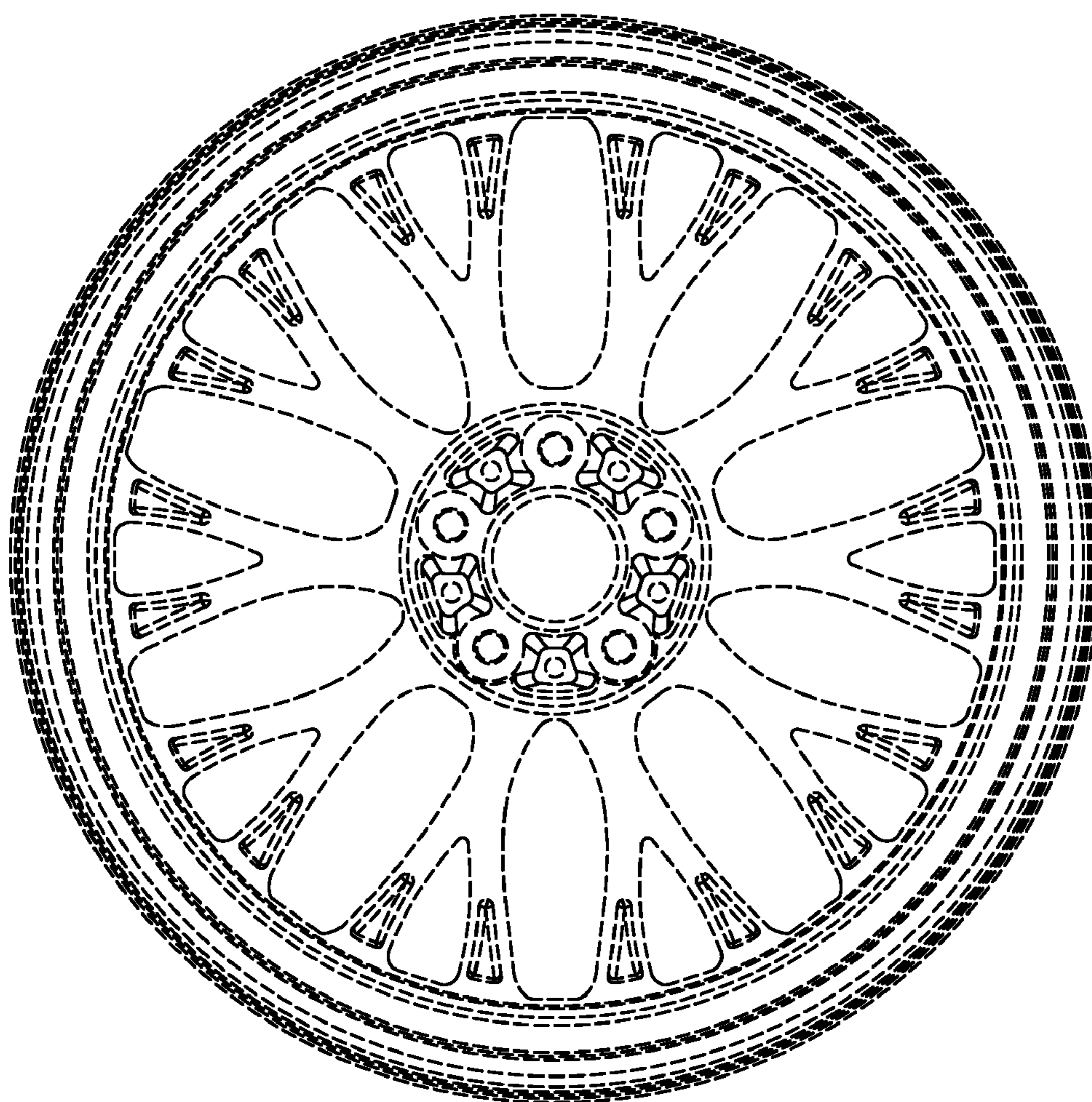
*Fig. 11*



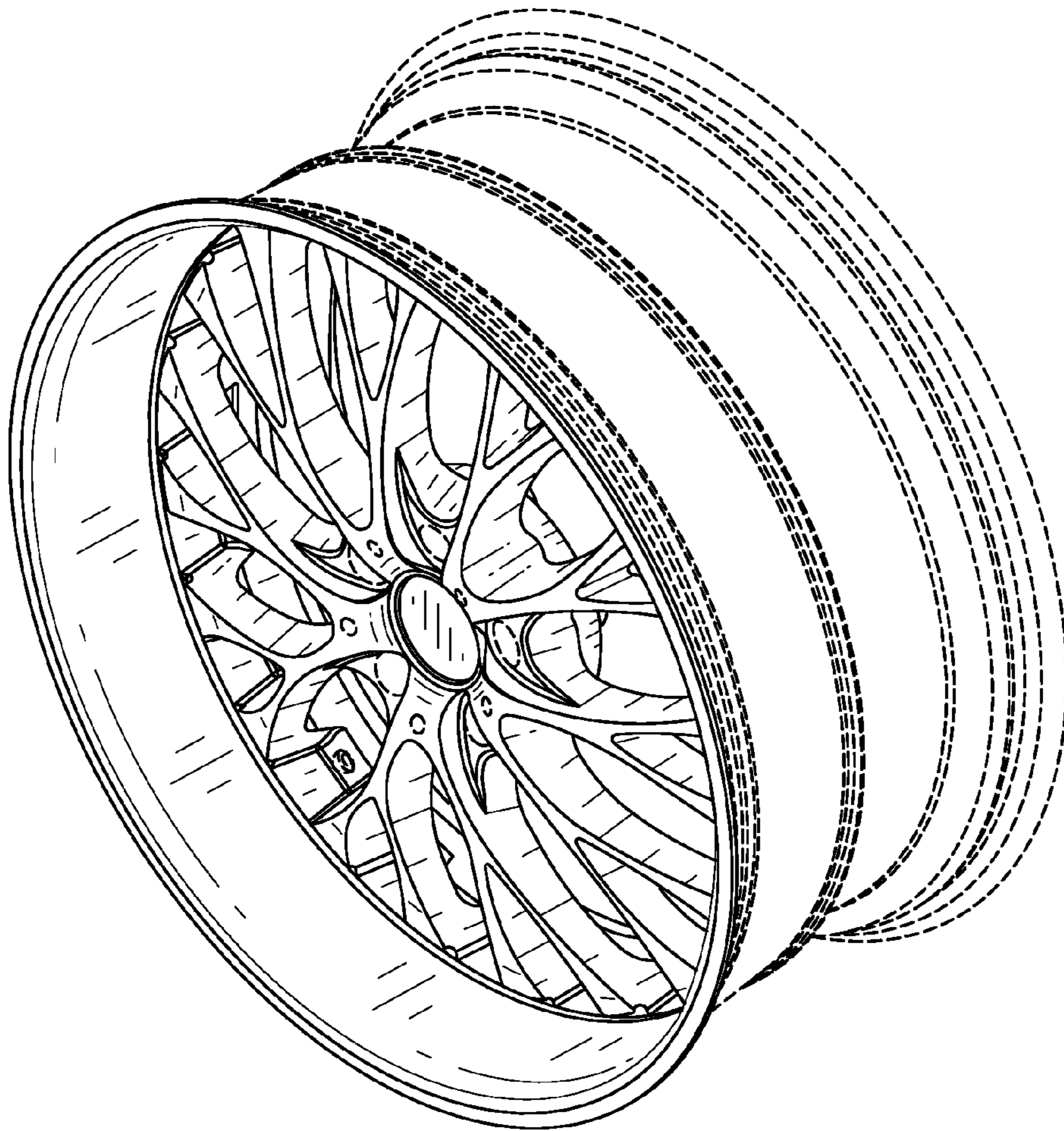
*Fig. 12*



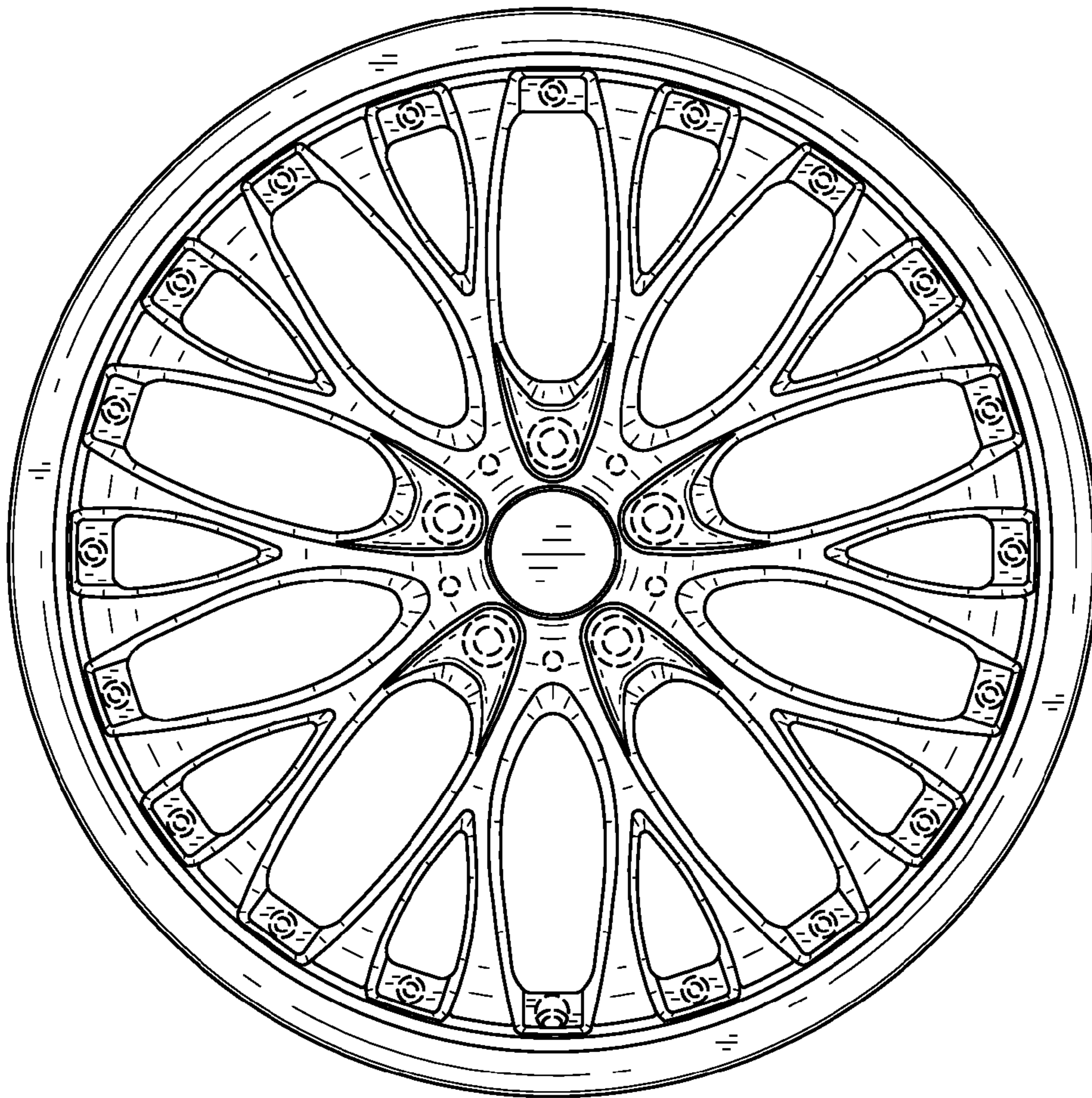
*Fig. 13*



*Fig. 14*



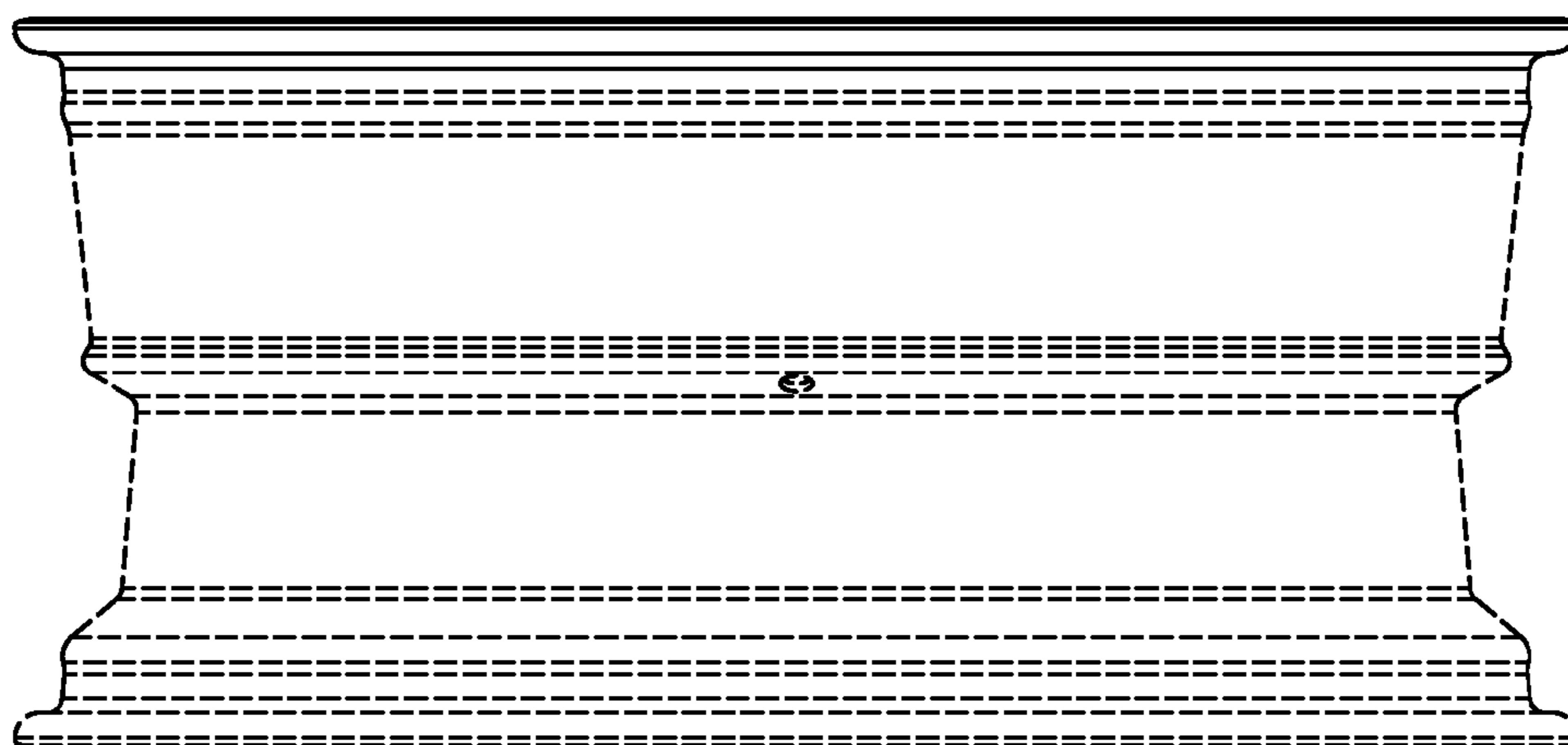
*Fig. 15*



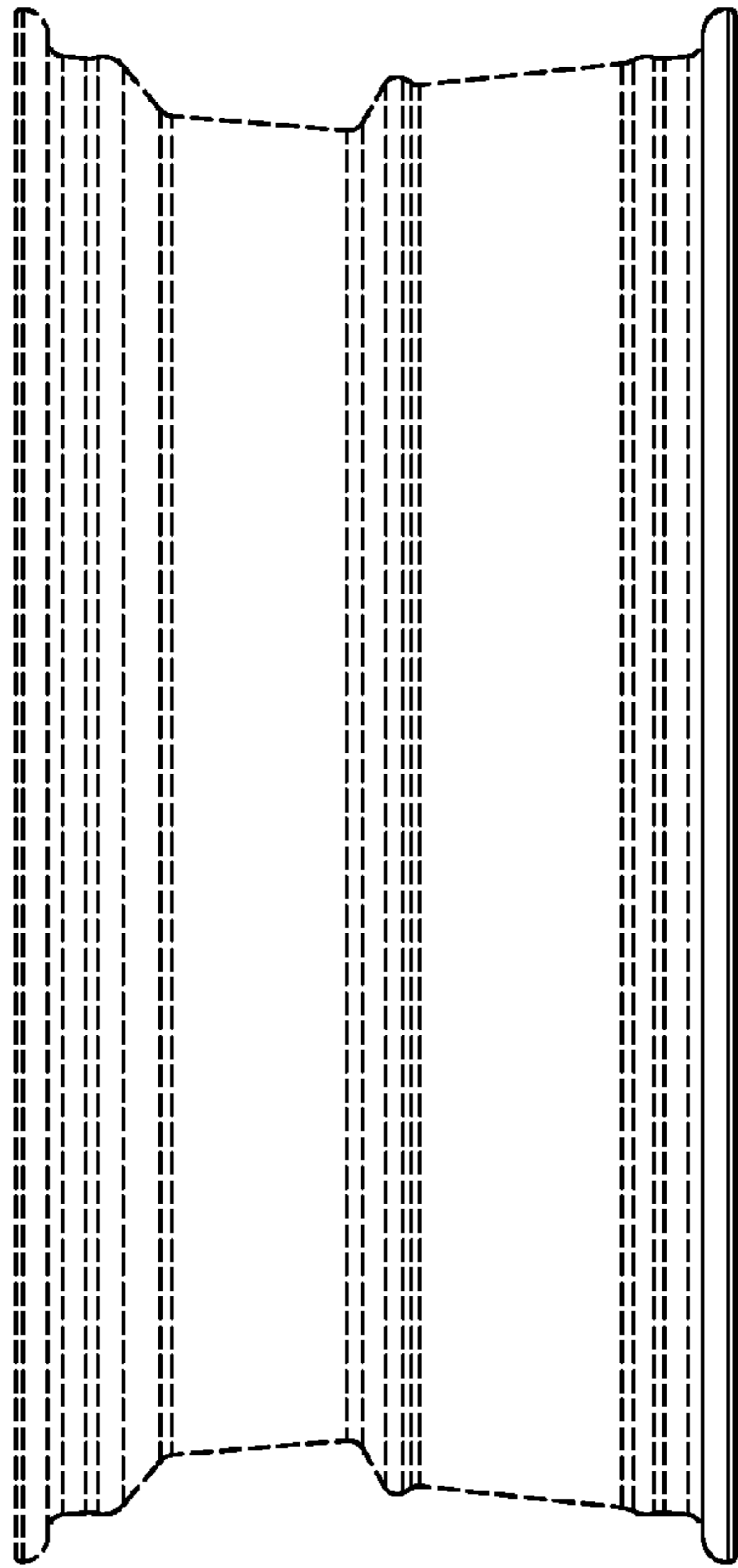
*Fig. 16*



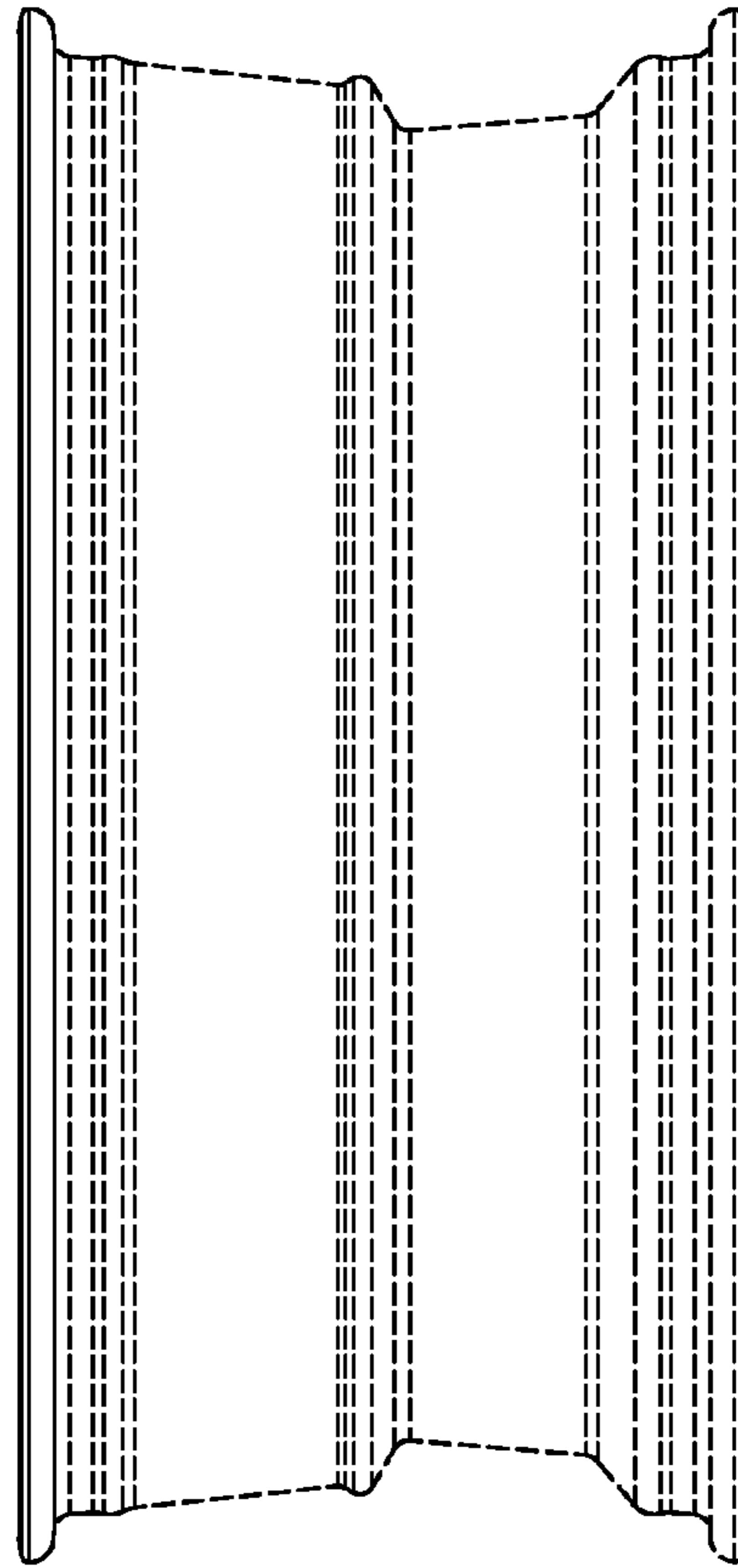
*Fig. 17*



*Fig. 18*



*Fig. 19*



*Fig. 20*

