



US00D630139S

(12) **United States Design Patent**
Schneider

(10) **Patent No.:** **US D630,139 S**
(45) **Date of Patent:** **** Jan. 4, 2011**

(54) **FRONT BUMPER FOR A VEHICLE**

WO WO DM/066987 10/2005

(75) Inventor: **Alexander Schneider**, Munich (DE)

* cited by examiner

(73) Assignee: **Bayerische Motoren Werke Aktiengesellschaft**, Munich (DE)

Primary Examiner—Melody N Brown
(74) *Attorney, Agent, or Firm*—Crowell & Moring LLP

(**) Term: **14 Years**

(57) **CLAIM**

(21) Appl. No.: **29/347,795**

The ornamental design for a front bumper for a vehicle, as shown and described.

(22) Filed: **Jun. 7, 2010**

(30) **Foreign Application Priority Data**

DESCRIPTION

Dec. 8, 2009 (DE) 402009006095

(51) **LOC (9) Cl.** **12-16**

(52) **U.S. Cl.** **D12/169**

(58) **Field of Classification Search** D12/169,
D12/196, 171, 163, 216, 90–92, 86; 293/102,
293/113, 115, 117, 120; 296/180.1, 180.2
See application file for complete search history.

This application contains subject matter related to the following co-pending U.S. design patent applications:

Application Ser. No. 29/347,801, filed herewith and entitled “Vehicle, Toy, and/or Replicas Thereof”; and

Application Ser. No. 29/347,793, filed herewith and entitled “Front Bumper for a Vehicle”.

FIG. 1 is a right perspective view of a front bumper for a vehicle according to my design;

FIG. 2 is a left perspective view thereof;

FIG. 3 is a front view thereof;

FIG. 4 is a left side view thereof;

FIG. 5 is a right side view thereof;

FIG. 6 is a top view thereof; and,

FIG. 7 is a bottom view thereof.

The broken lines are for illustrative purposes only and form no part of the claimed design.

(56) **References Cited**

U.S. PATENT DOCUMENTS

D511,724 S	*	11/2005	Sugimoto	D12/169
D531,099 S	*	10/2006	Wu	D12/169
D544,415 S	*	6/2007	Okamoto	D12/169
D559,743 S	*	1/2008	Nakamuta et al.	D12/169
D591,211 S	*	4/2009	Hayashi et al.	D12/169
D595,623 S	*	7/2009	Wagner et al.	D12/169
D597,000 S	*	7/2009	Golden et al.	D12/169
D605,098 S	*	12/2009	Bennett et al.	D12/169

FOREIGN PATENT DOCUMENTS

WO WO DM/064839 2/2004

1 Claim, 3 Drawing Sheets

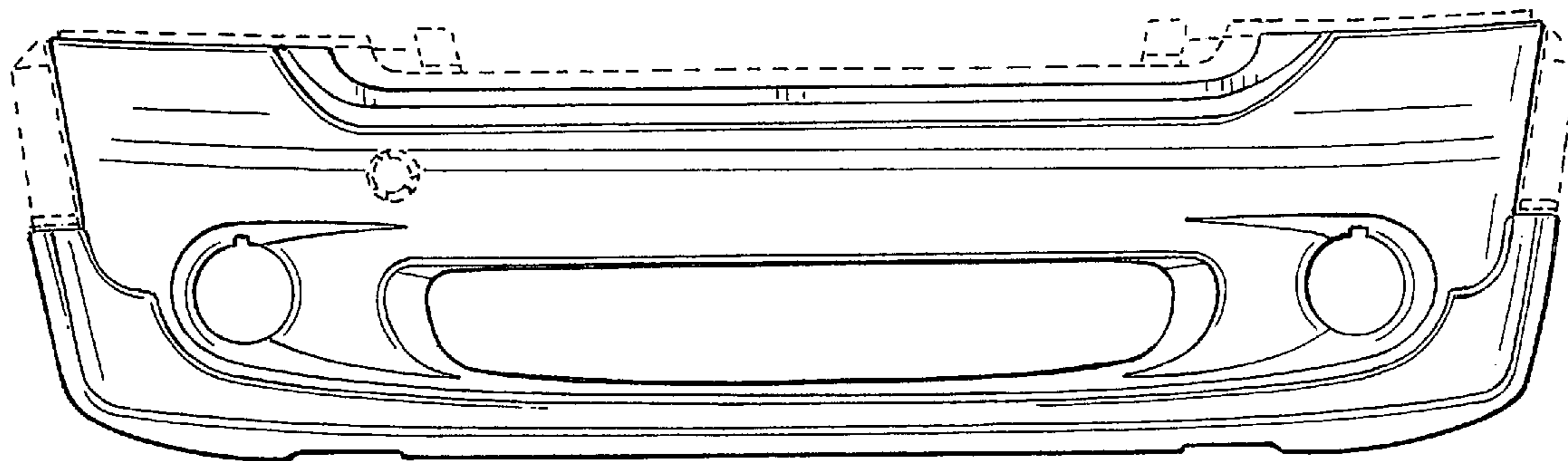

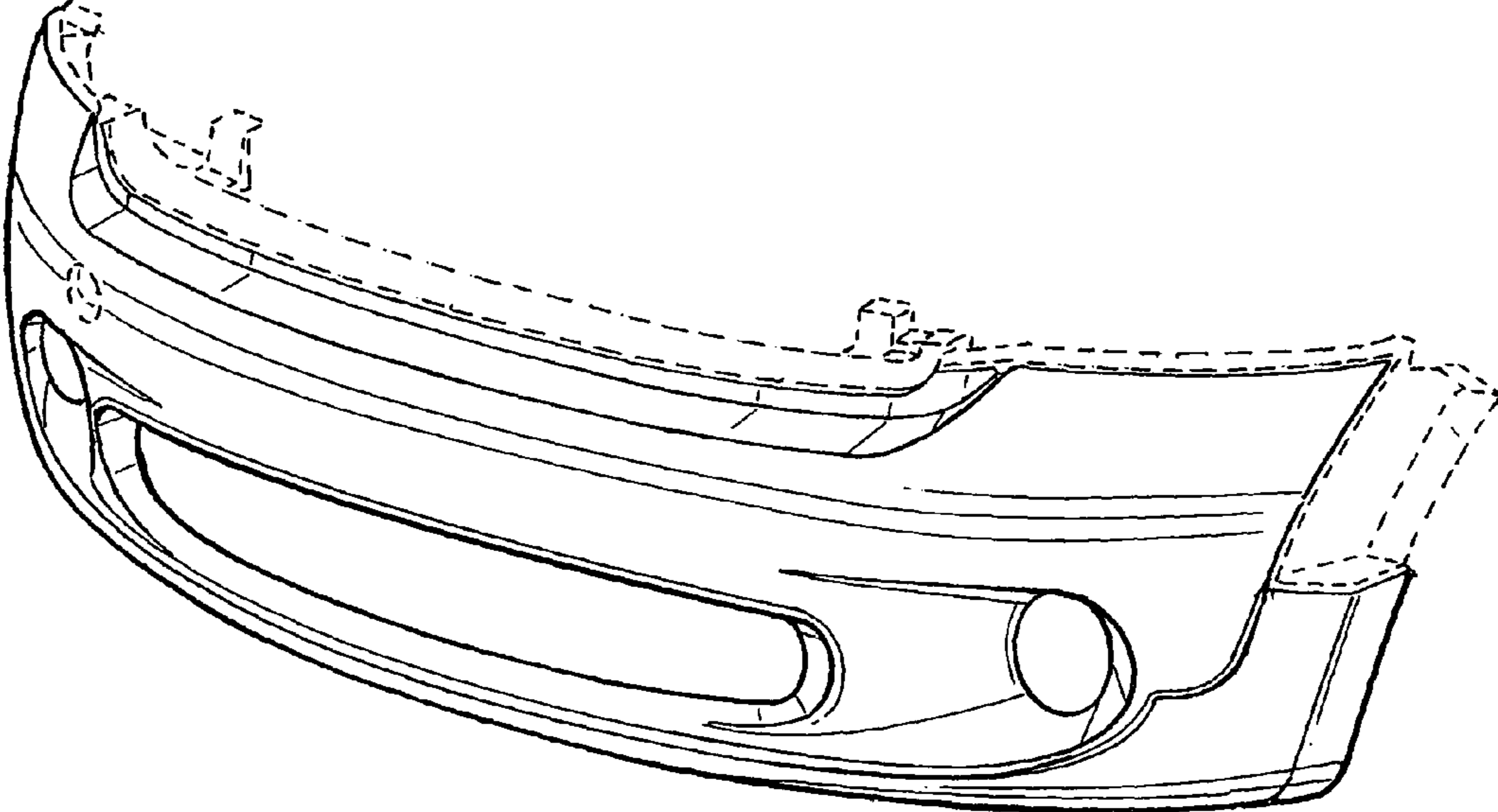

FIG. 1

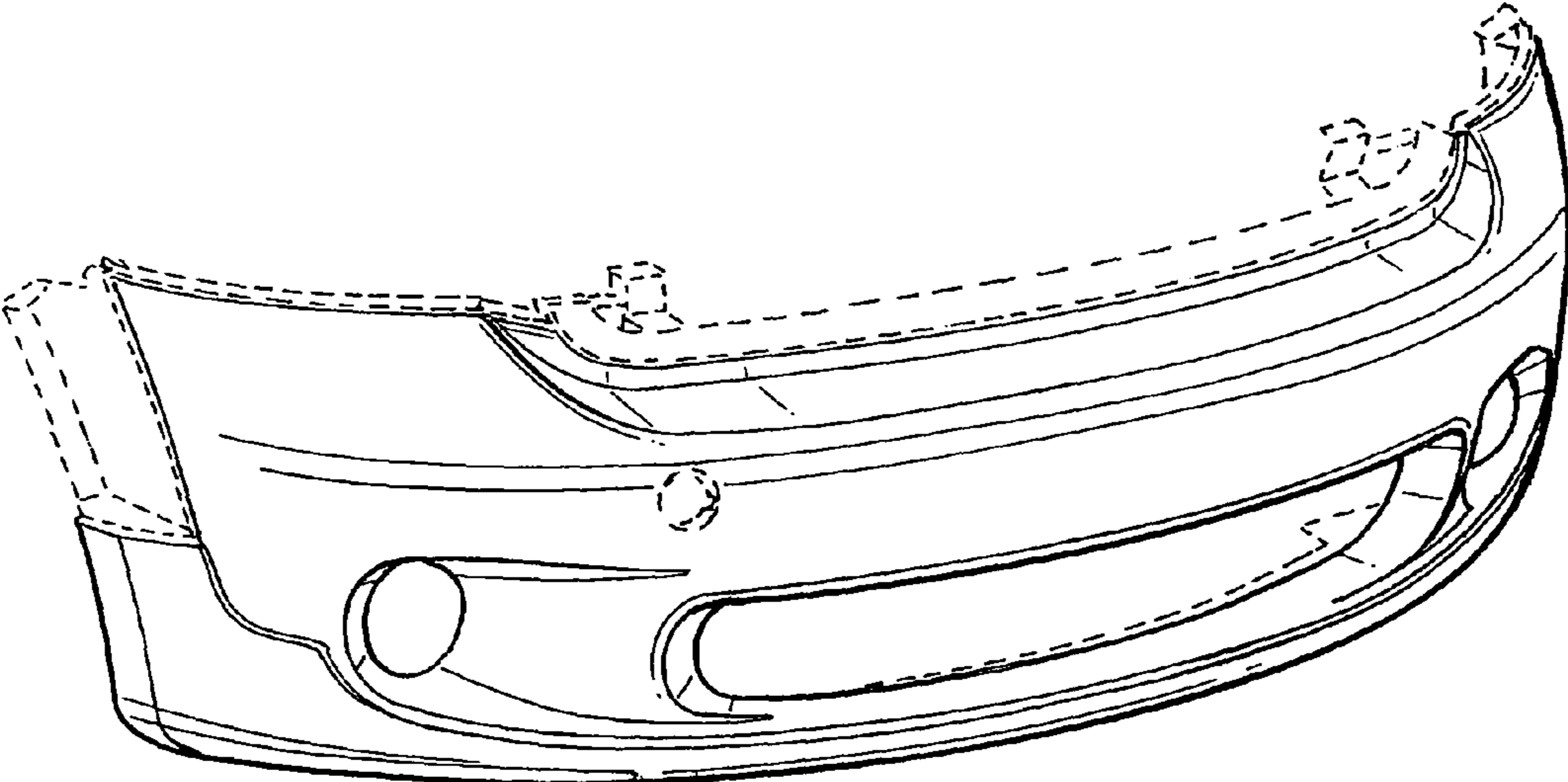

FIG. 2

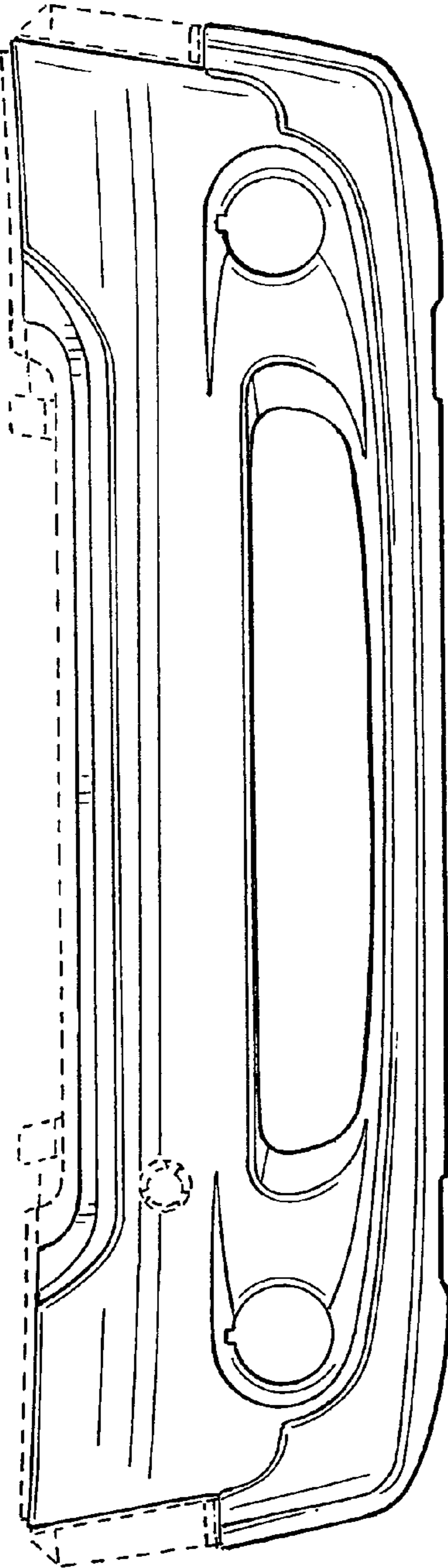

FIG. 3

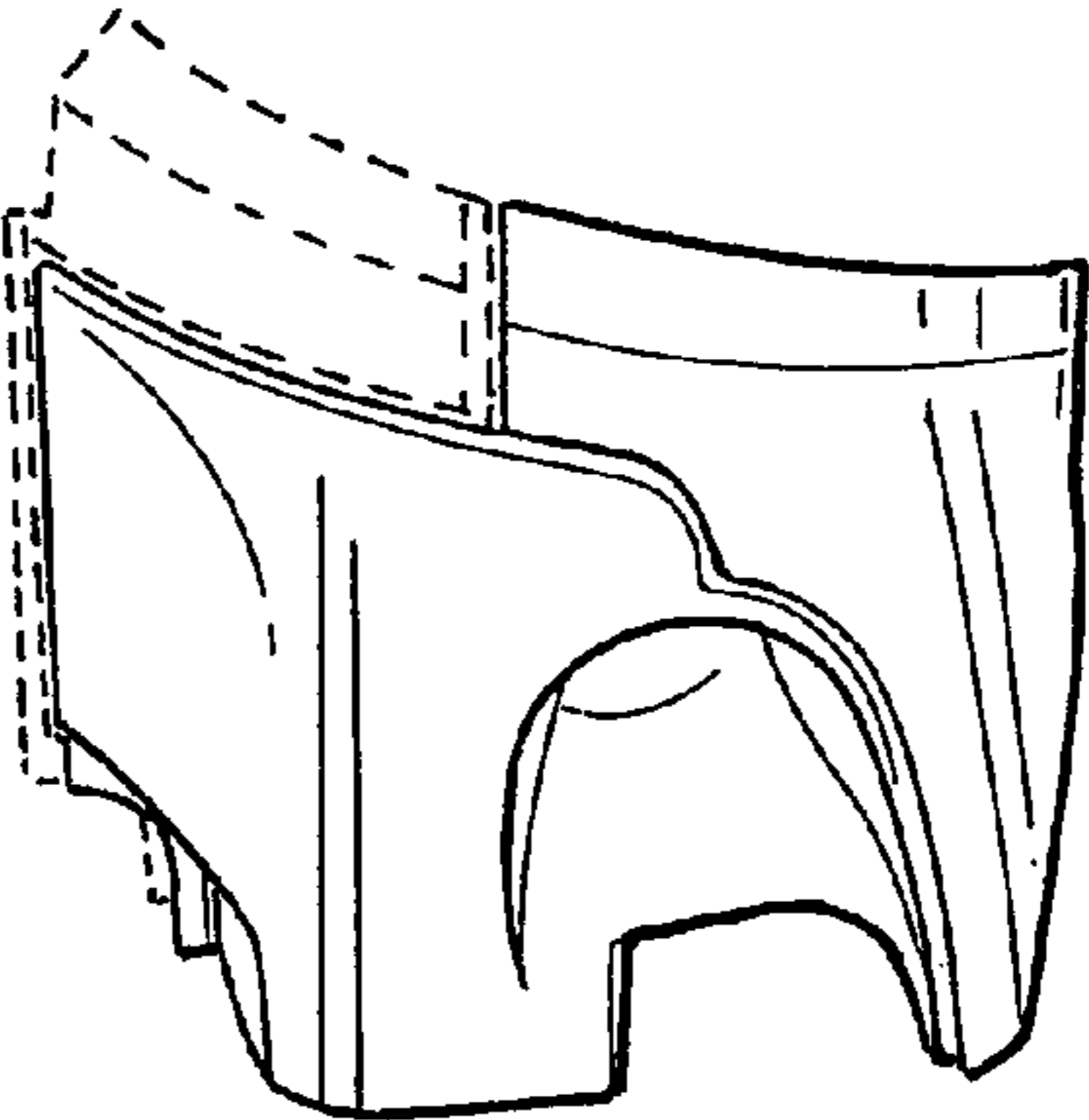

FIG. 5

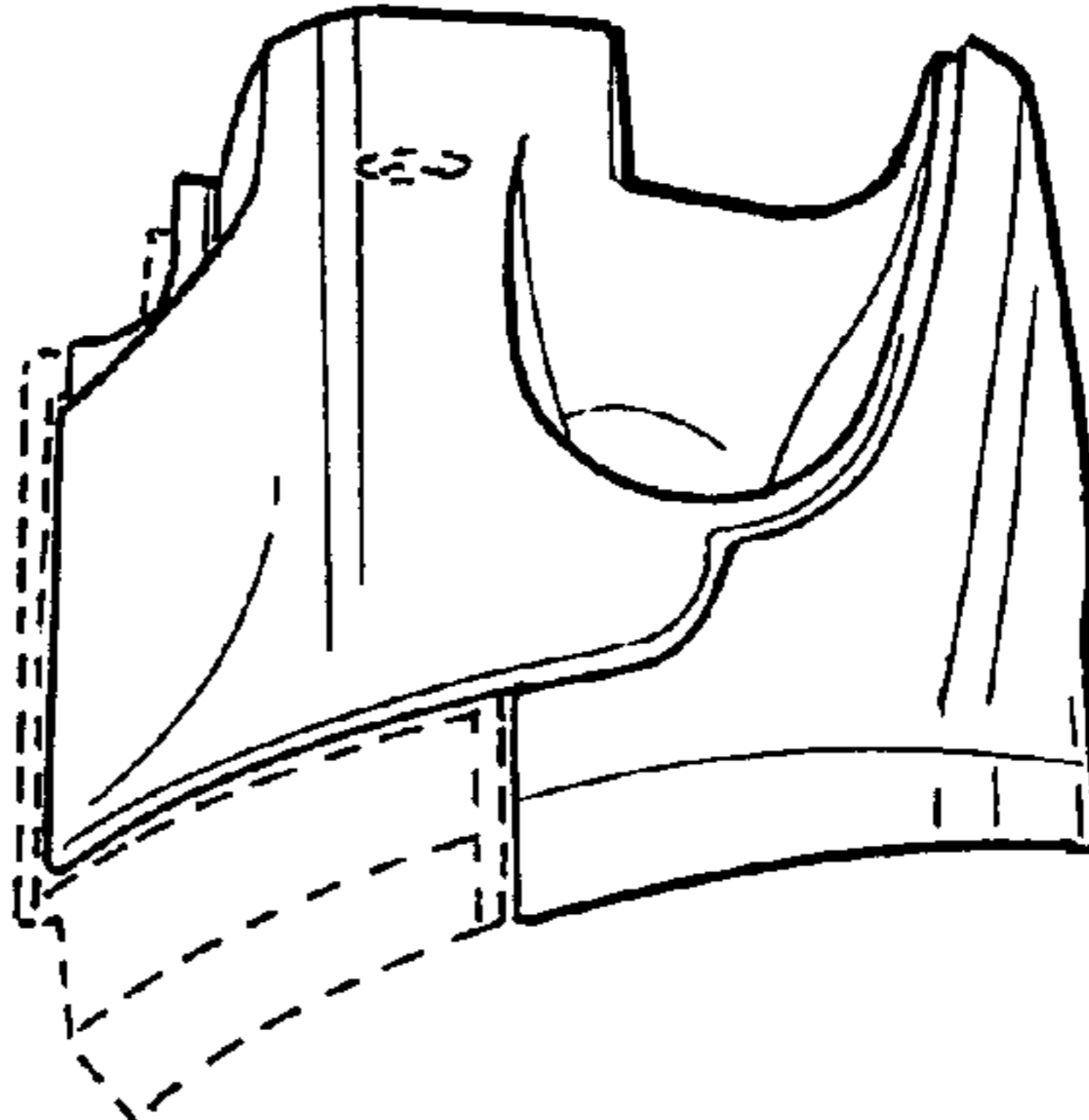

FIG. 4

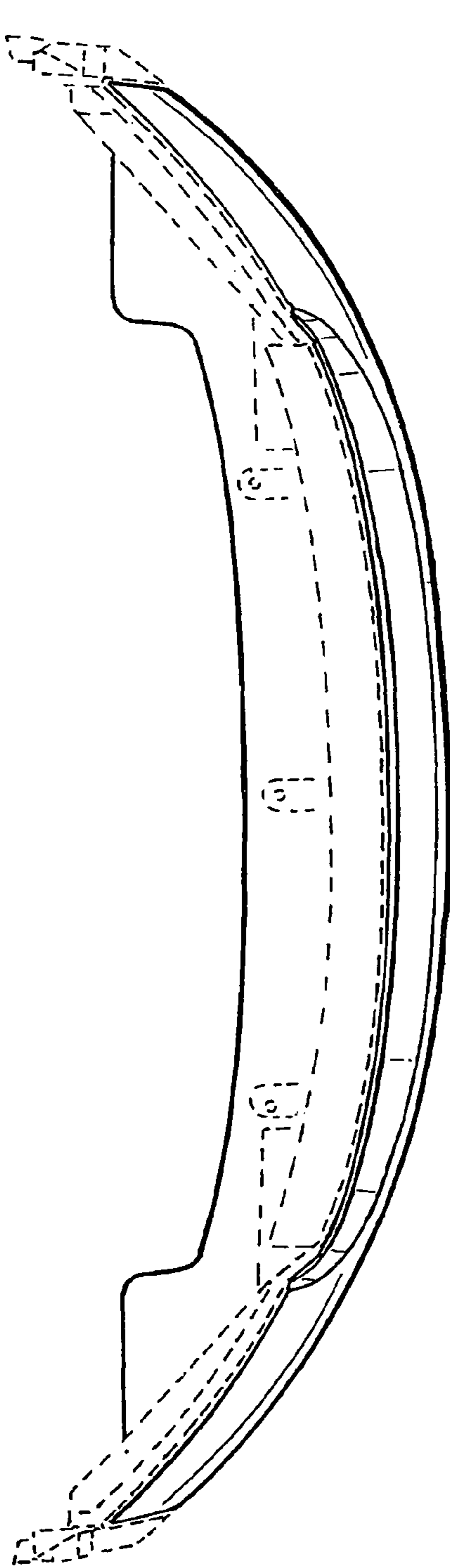

FIG. 6

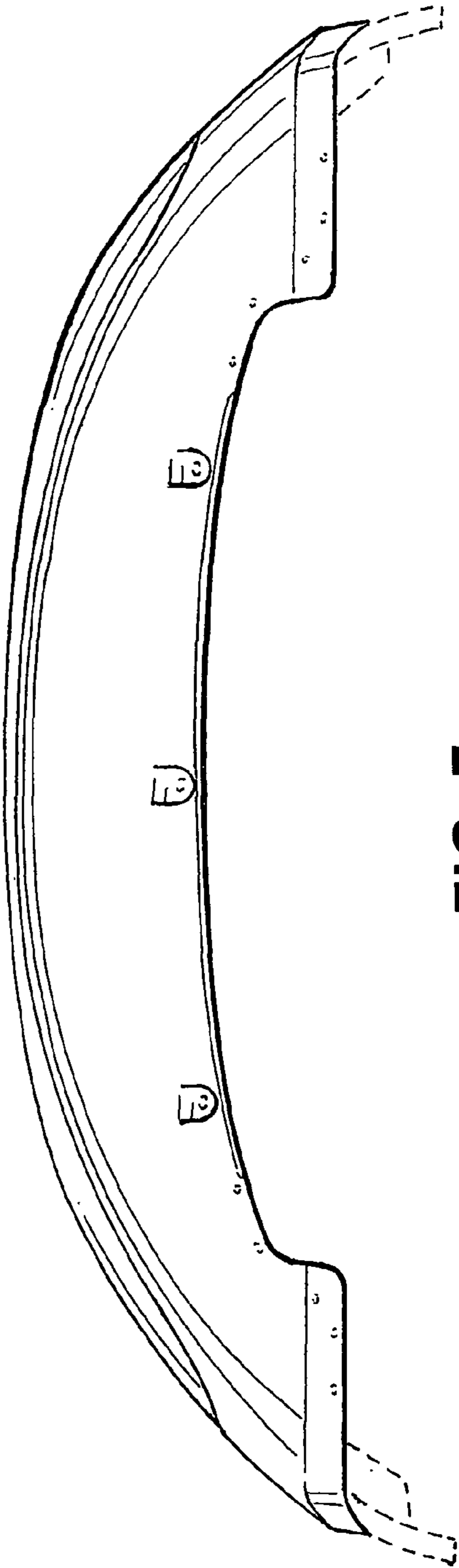

FIG. 7