



US00D630117S

(12) **United States Design Patent**
Madina

(10) **Patent No.:** **US D630,117 S**
(45) **Date of Patent:** **** Jan. 4, 2011**

(54) **ROADSIDE SAFETY BARRIER**

(74) *Attorney, Agent, or Firm*—K&L Gates LLP

(75) **Inventor:** **Iñaki Madina**, Vitoria (ES)

(57) **CLAIM**

(73) **Assignee:** **Celaya Emparanza y Galdos Internacional, S.A.**, Vitoria, Alava (ES)

I claim the ornamental design for a roadside safety barrier, as shown and described.

(**) **Term:** **14 Years**

(21) **Appl. No.:** **29/356,063**

(22) **Filed:** **Feb. 19, 2010**

(30) **Foreign Application Priority Data**

Sep. 4, 2009 (EP) 001607763-0001

(51) **LOC (9) Cl.** **10-05**

(52) **U.S. Cl.** **D10/113**

(58) **Field of Classification Search** D10/109;
116/211, 209, 234, 63 R, 63 P, 63 C, 63 T;
404/9-16; D25/132

See application file for complete search history.

(56) **References Cited**

U.S. PATENT DOCUMENTS

4,806,044 A * 2/1989 Duckett 404/6
D341,098 S * 11/1993 Yodock D10/109
D343,369 S * 1/1994 Sprague D10/109
5,988,934 A * 11/1999 Wasserstrom 404/6

(Continued)

FOREIGN PATENT DOCUMENTS

EP 000380118-01 9/2005

(Continued)

OTHER PUBLICATIONS

Barreras New Jersey de plastico—Cargo barrier, ITSA Urban Products, Industrial de Transformados, S.A. L'Arboc, Spain.

(Continued)

Primary Examiner—Caron Veynar

Assistant Examiner—George D Kirschbaum

DESCRIPTION

FIG. 1 is a rear view of an open embodiment of a roadside safety barrier;

FIG. 2 is a bottom view of the roadside safety barrier shown in FIG. 1;

FIG. 3 is a front view of the roadside safety barrier shown in FIG. 1;

FIG. 4 is a perspective view of the roadside safety barrier shown in FIG. 1;

FIG. 5 is a left side view of the roadside safety barrier shown in FIG. 1;

FIG. 6 is a right side view of the roadside safety barrier shown in FIG. 1;

FIG. 7 is a top view of the roadside safety barrier shown in FIG. 1;

FIG. 8 is a rear view of a closed embodiment of a roadside safety barrier;

FIG. 9 is a bottom view of the roadside safety barrier shown in FIG. 8;

FIG. 10 is a front view of the roadside safety barrier shown in FIG. 8;

FIG. 11 is a perspective view of the roadside safety barrier shown in FIG. 8;

FIG. 12 is a left side view of the roadside safety barrier shown in FIG. 8;

FIG. 13 is a right side view of the roadside safety barrier shown in FIG. 8; and,

FIG. 14 is a top view of the roadside safety barrier shown in FIG. 8.

1 Claim, 14 Drawing Sheets

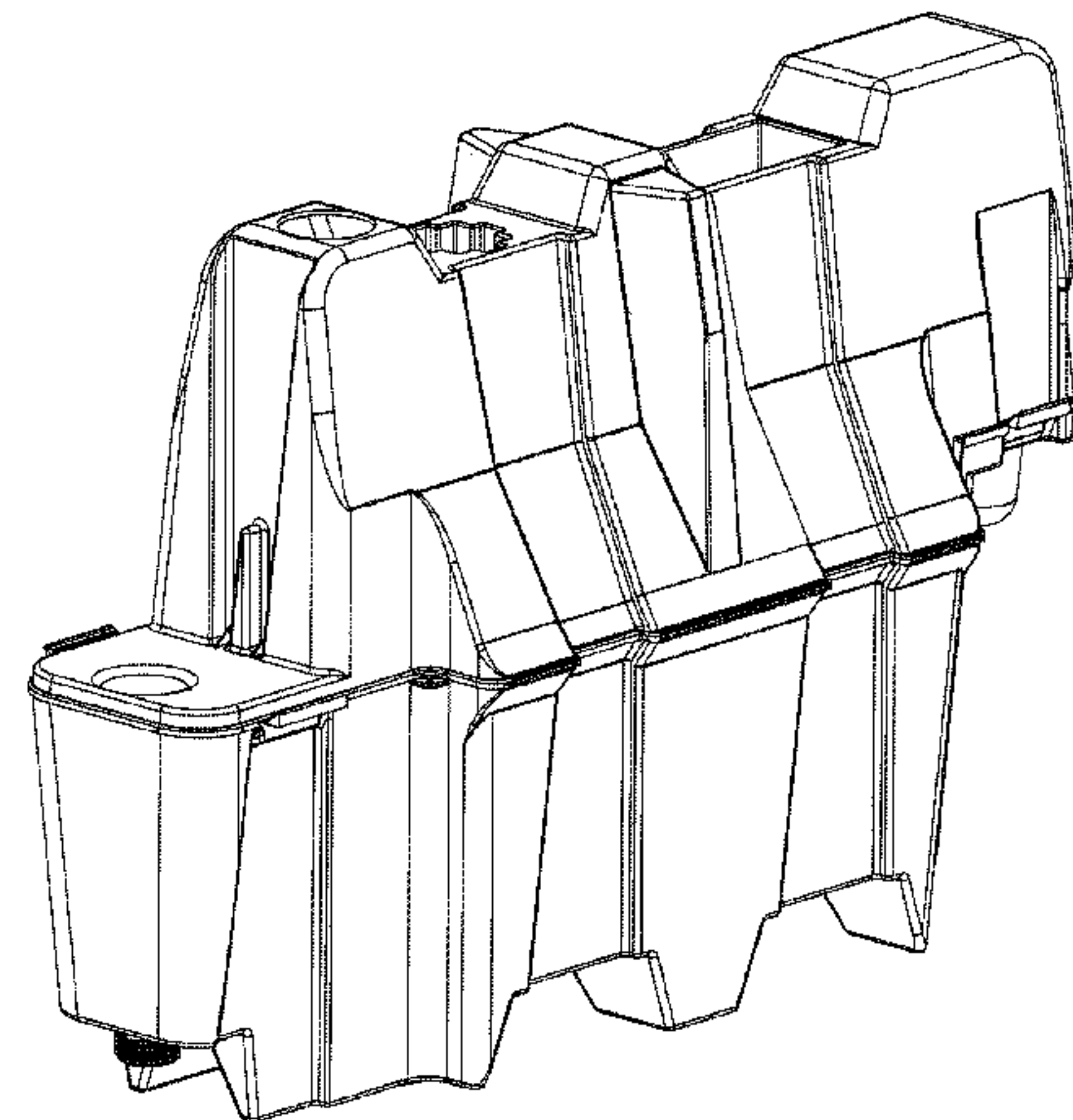
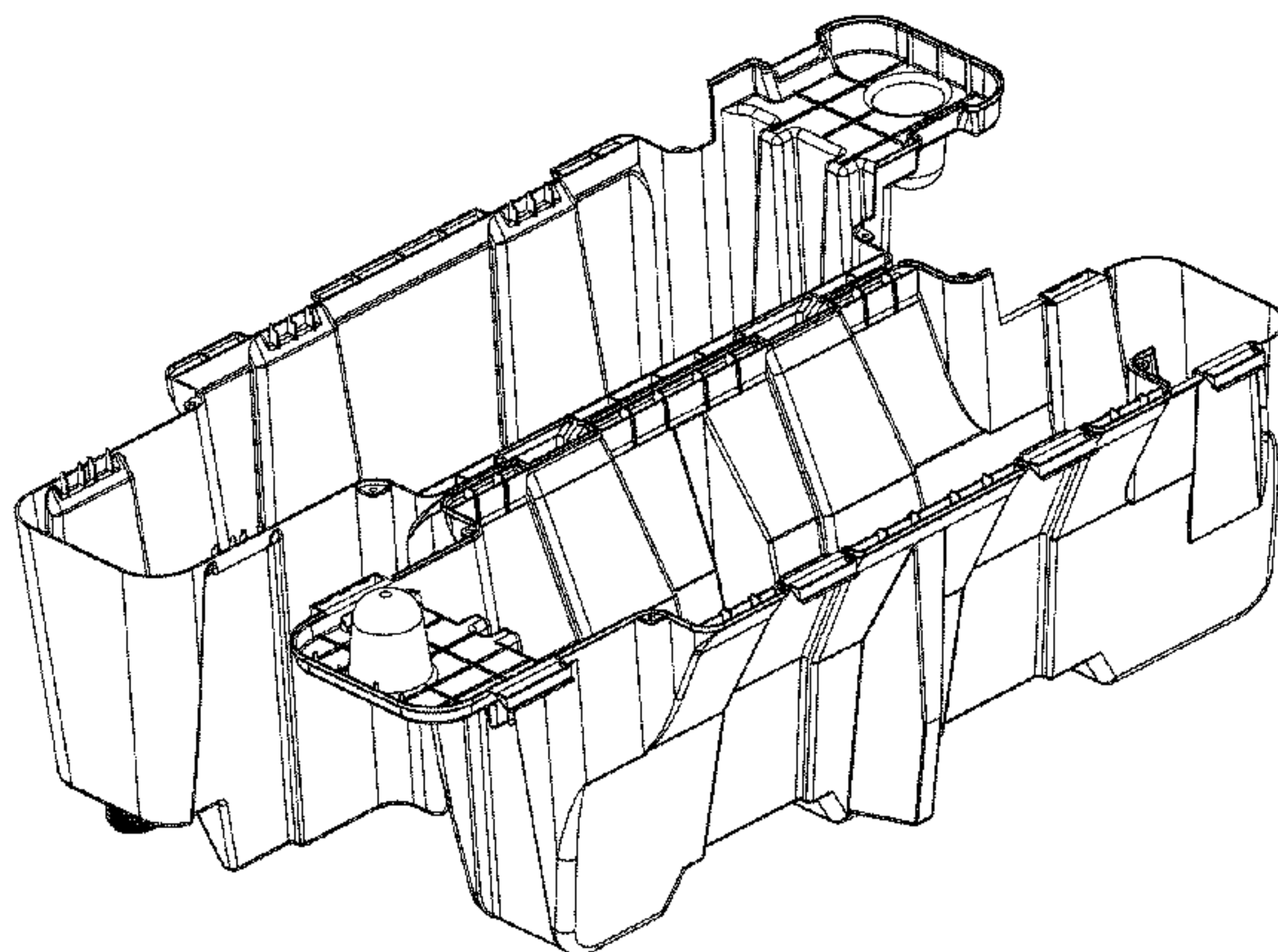

US D630,117 S

Page 2

U.S. PATENT DOCUMENTS

D431,657 S * 10/2000 Wasserstrom D25/113
D441,409 S 5/2001 Tagg
D461,735 S * 8/2002 Brown D10/113
D497,823 S * 11/2004 Brown D10/109
D498,163 S * 11/2004 Brown D10/109
D512,931 S * 12/2005 Brown D10/113
7,303,353 B2 * 12/2007 Carey 404/6
D596,062 S * 7/2009 Yodock et al. D10/113
2007/0206990 A1 9/2007 Yodock, III et al.
2008/0286041 A1 * 11/2008 Yodock et al. 404/6

2009/0003931 A1 1/2009 Christensen et al.

FOREIGN PATENT DOCUMENTS

FR 2893041 5/2007
WO DM 70467 6/2008

OTHER PUBLICATIONS

Signalisation Temporaire, Separateur de Voies "Emboitable", Nadia
Signalisation, Cholet Cedex.

* cited by examiner

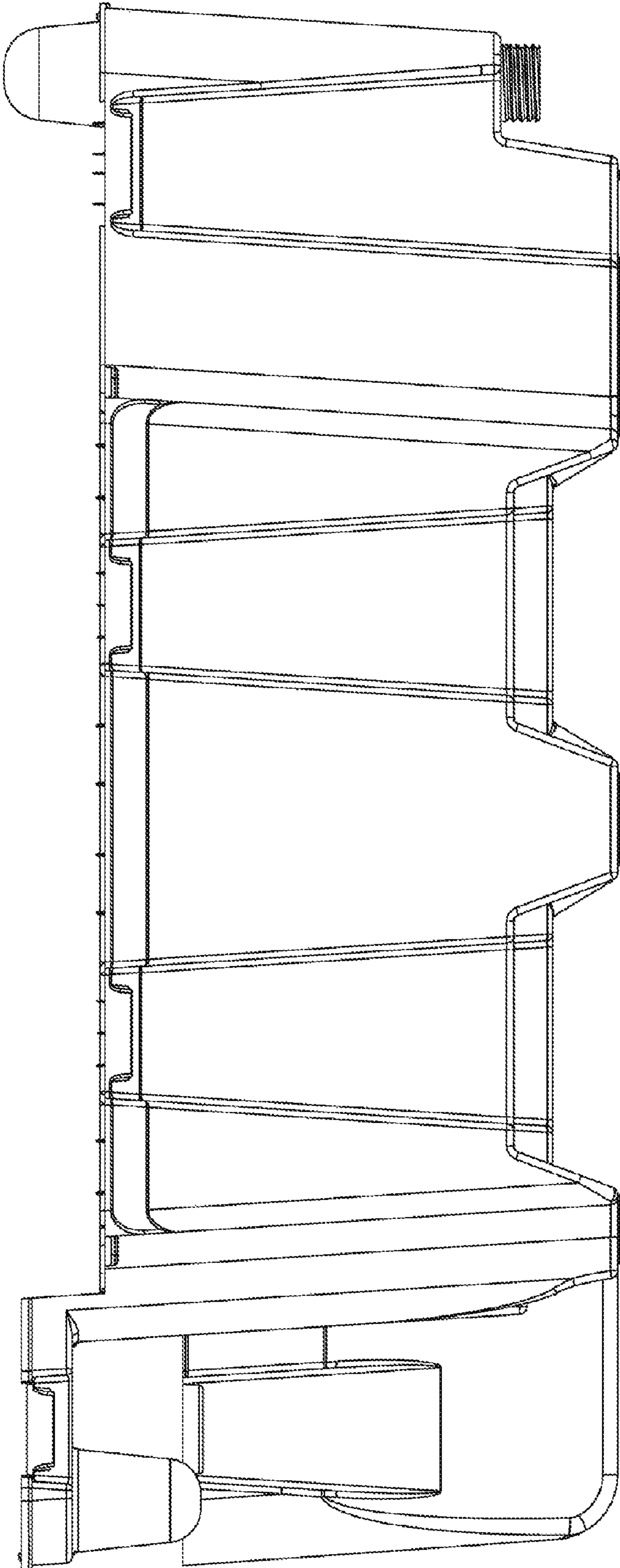

Fig. 1

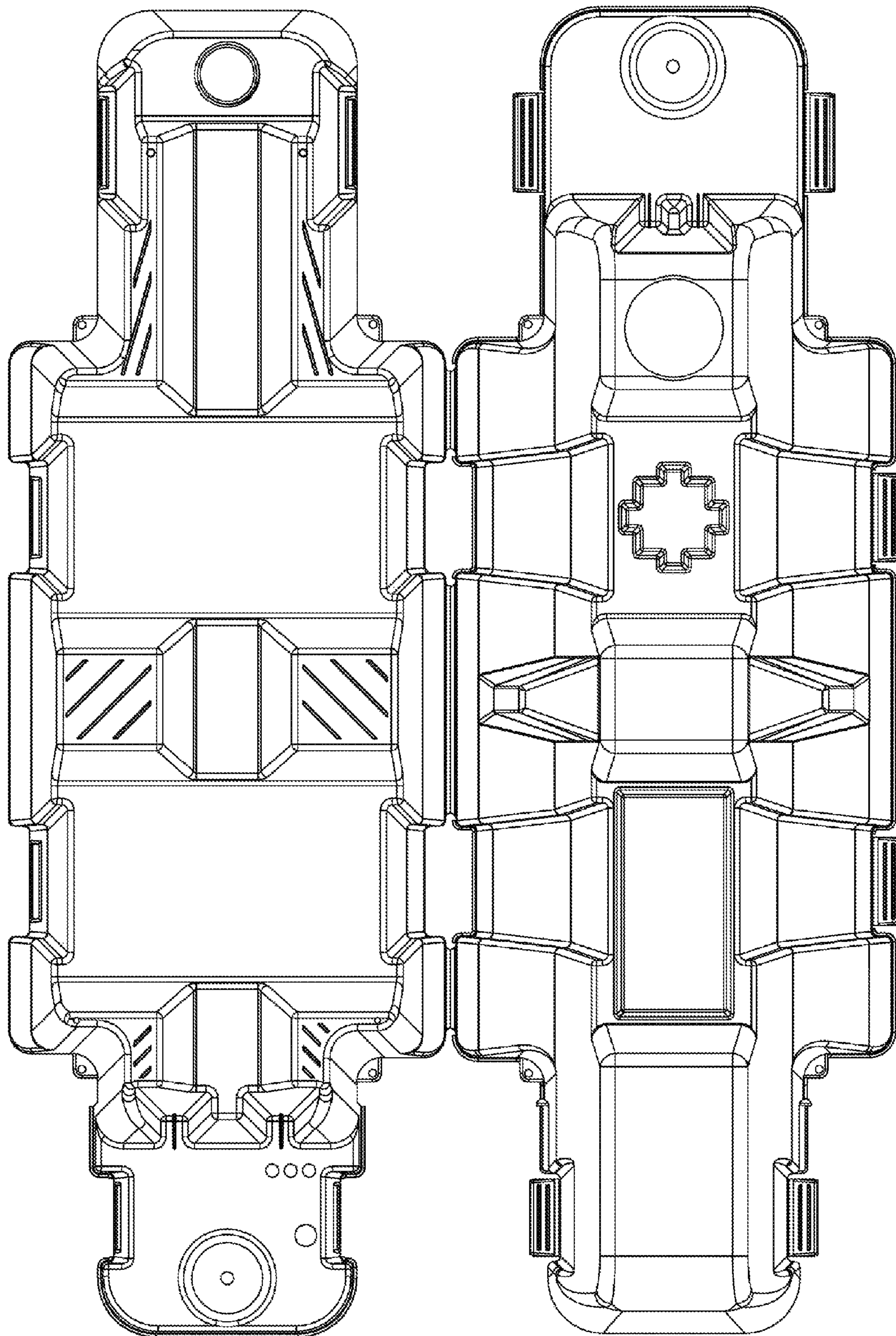

Fig. 2

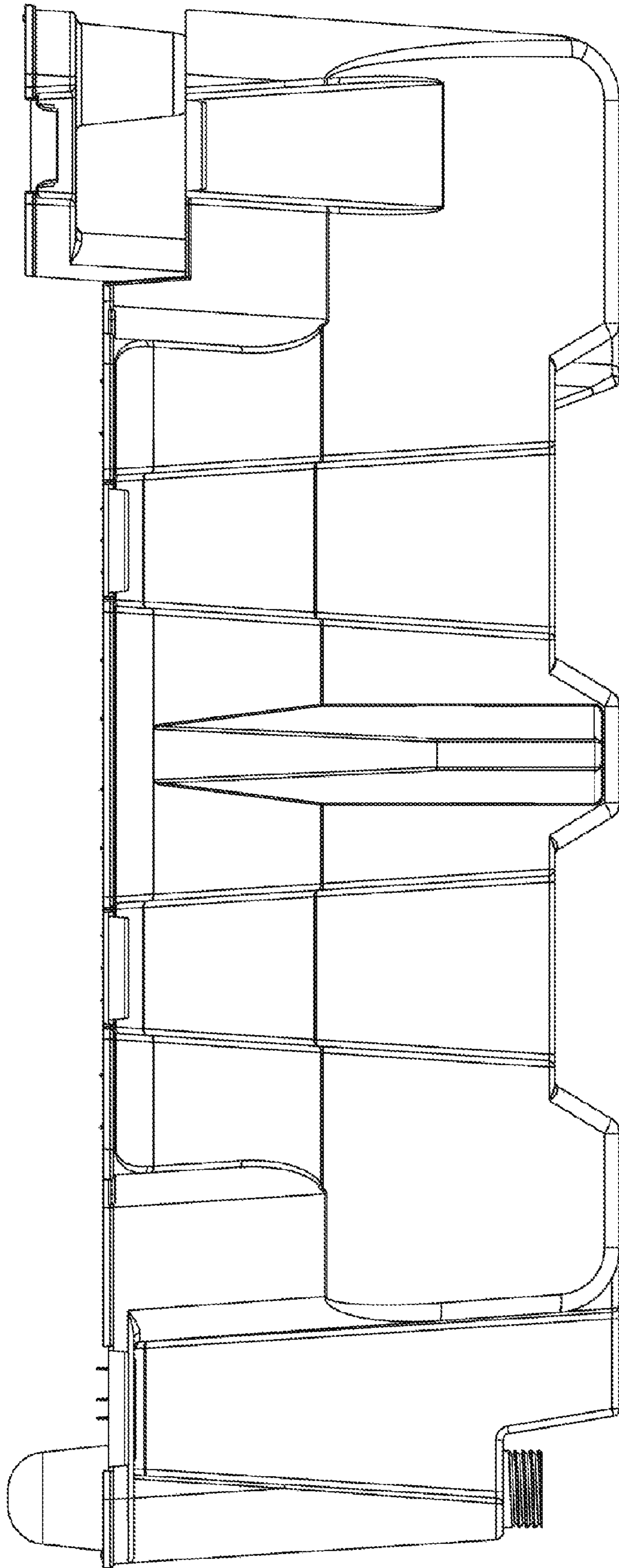

Fig. 3

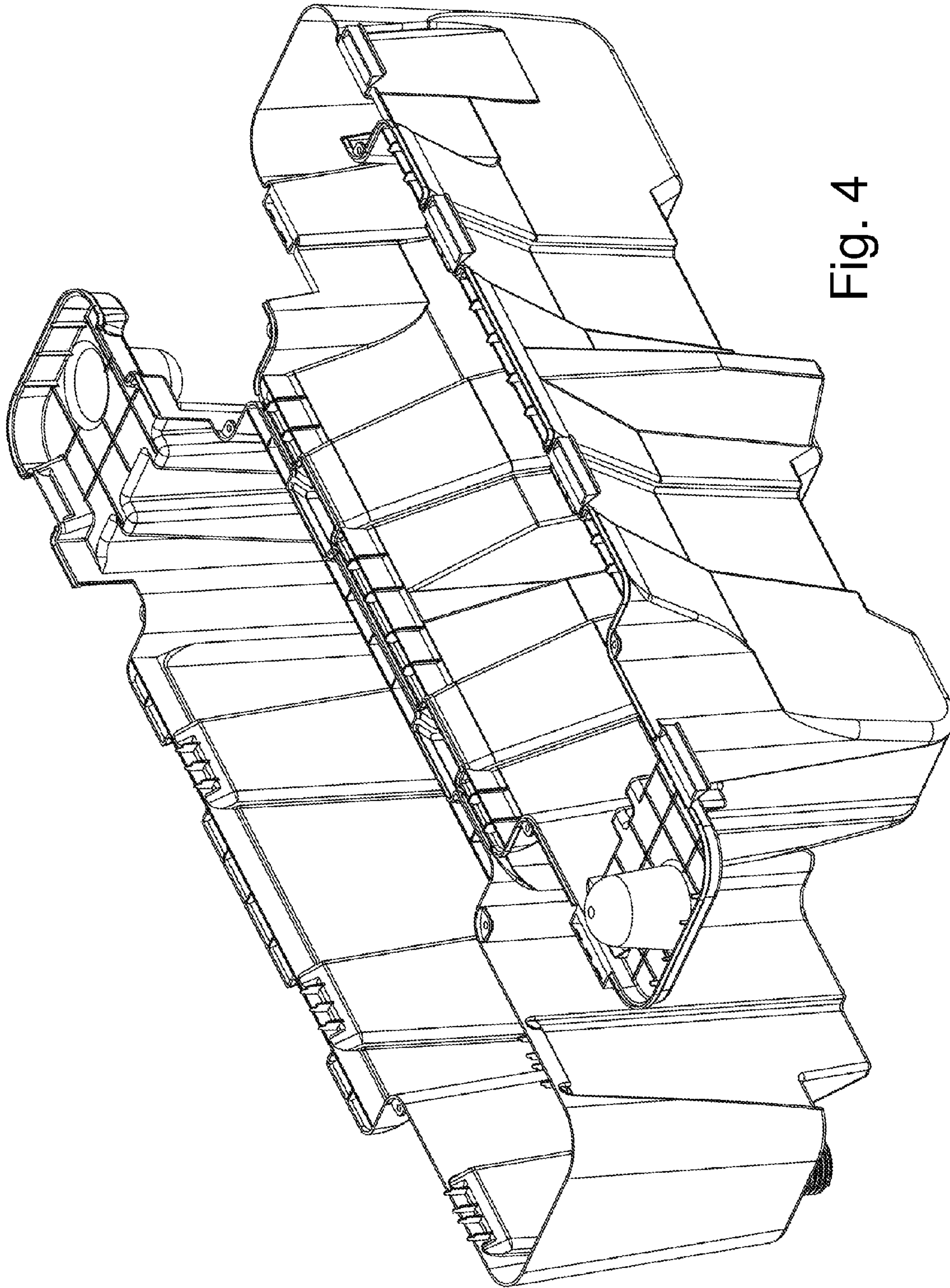

Fig. 4

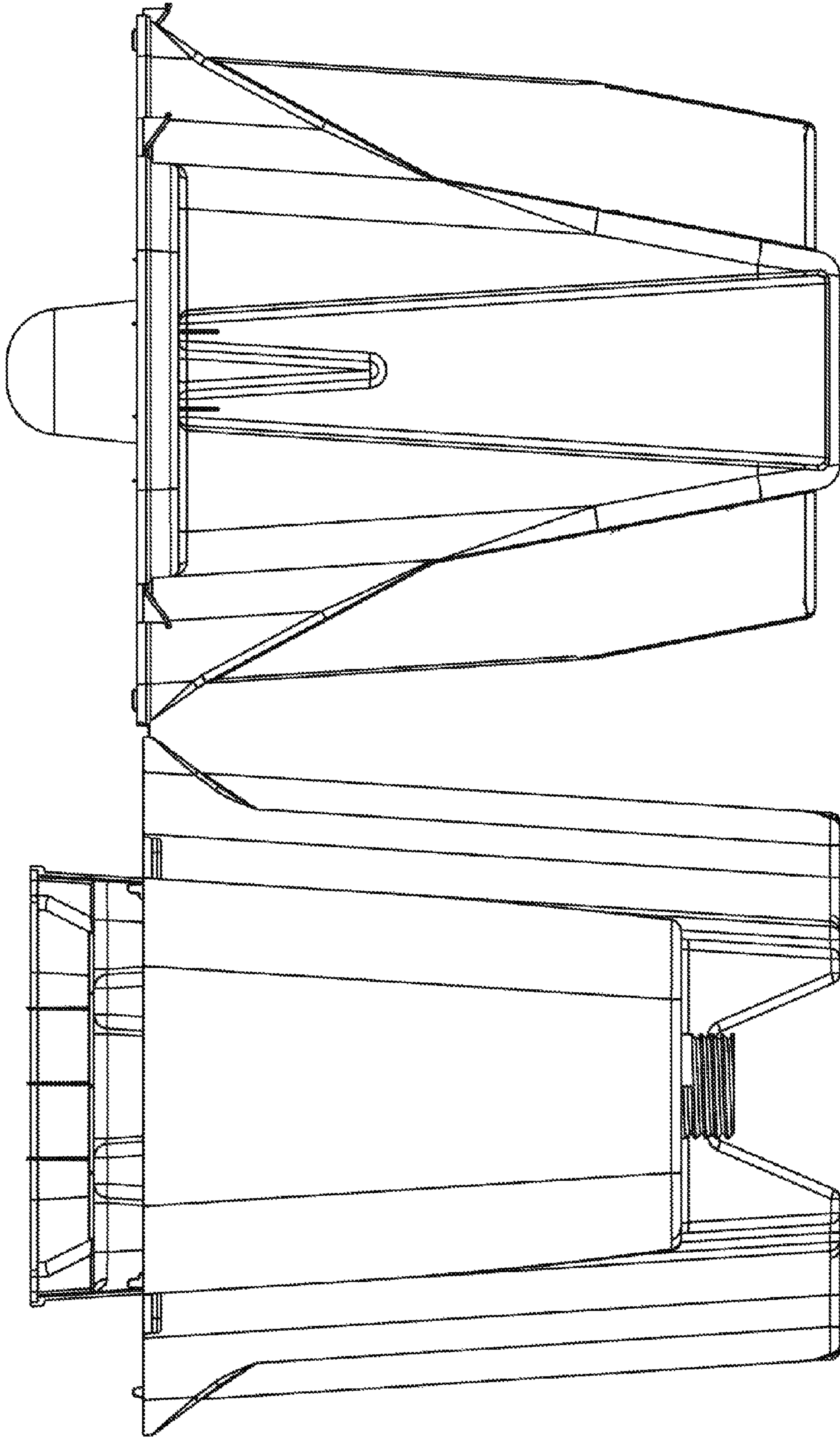

Fig. 5

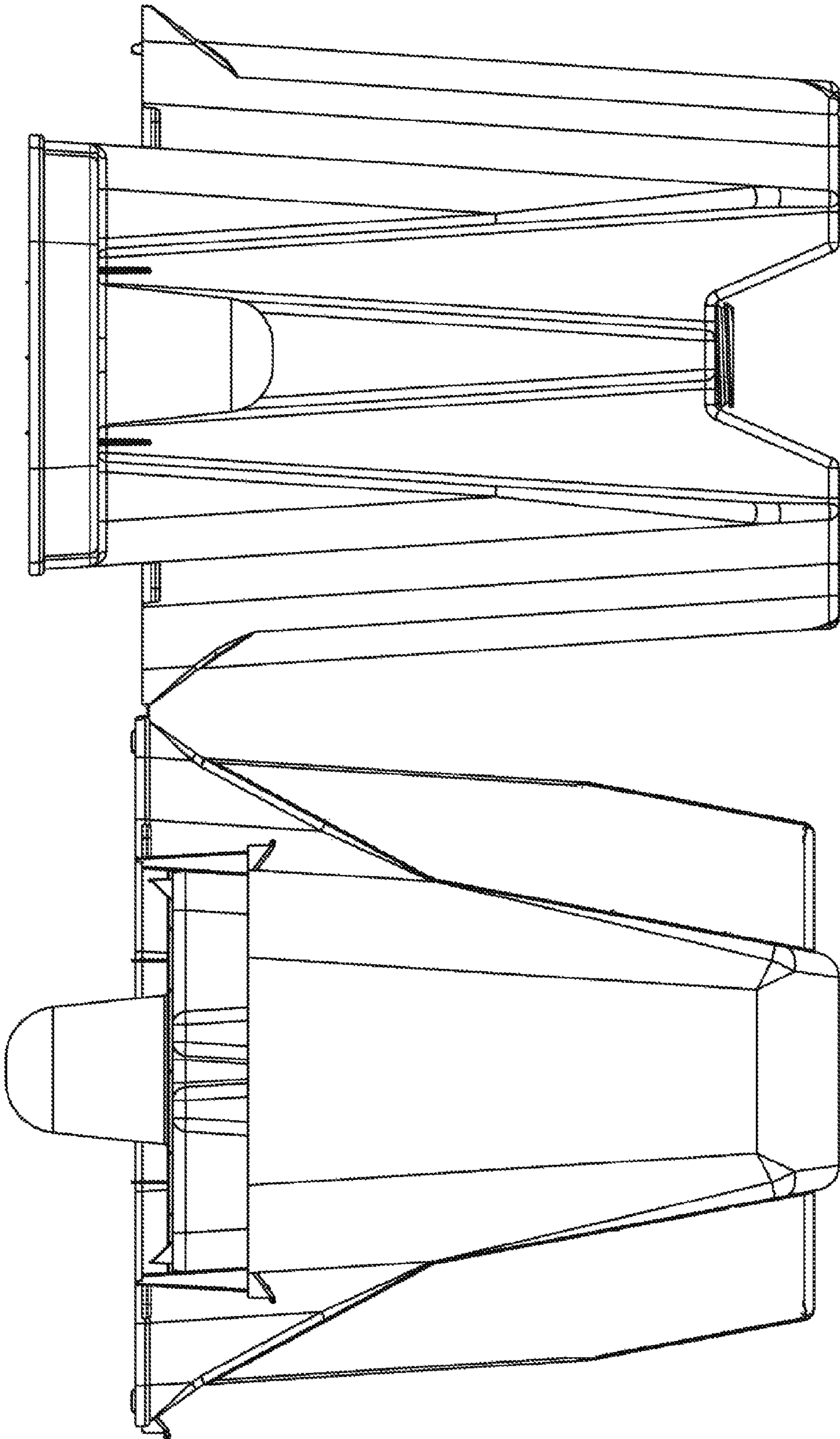

Fig. 6

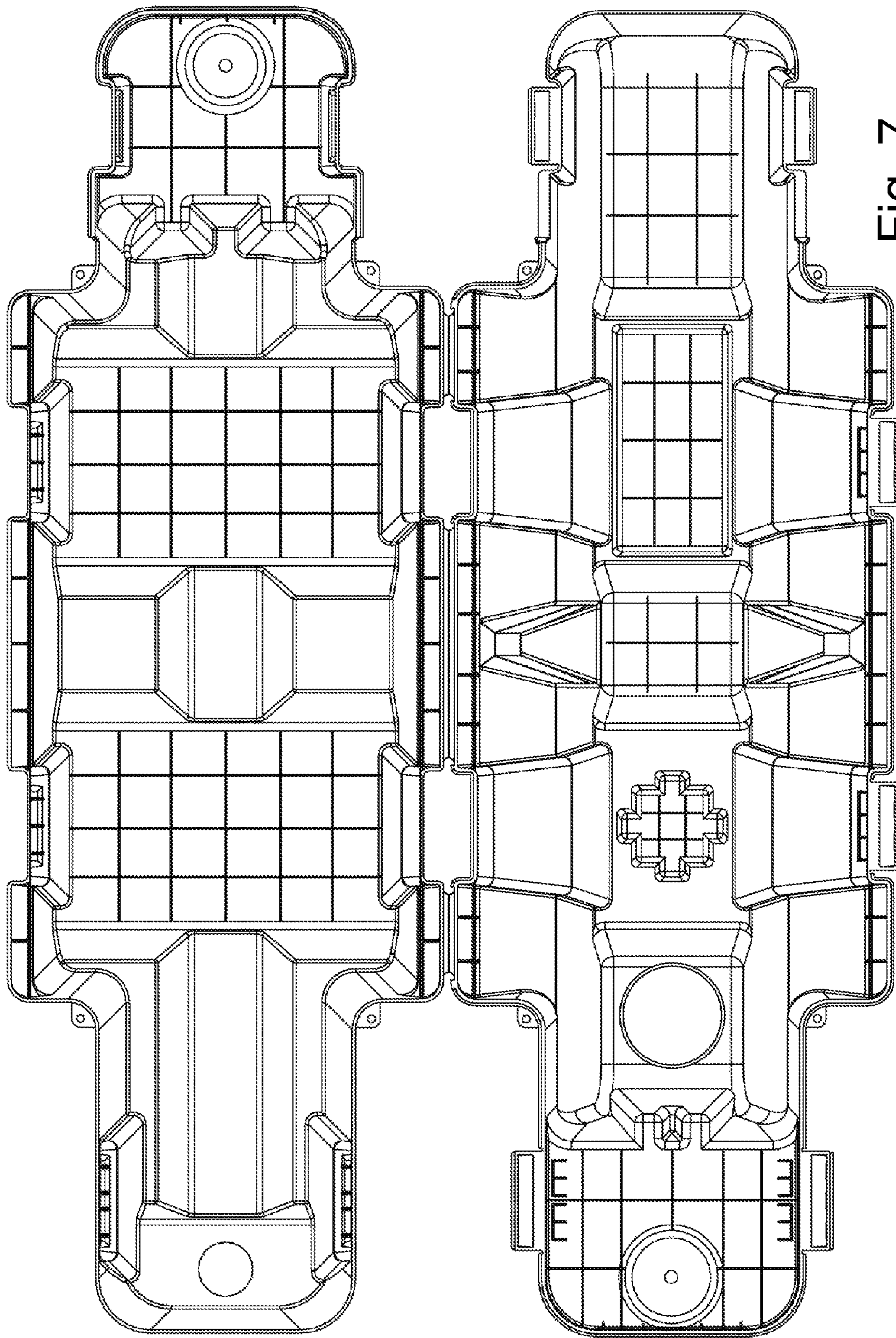

Fig. 7

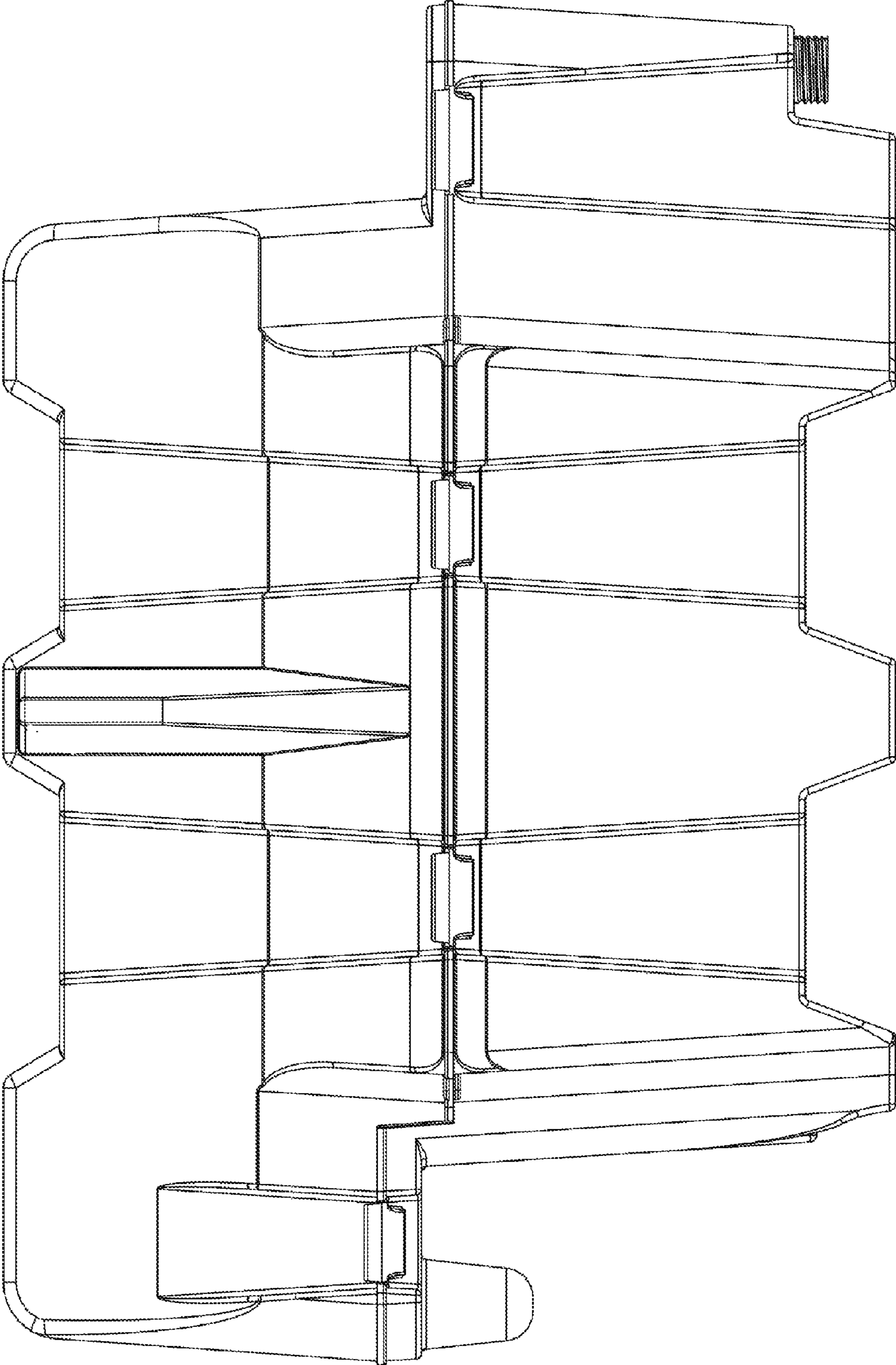

Fig. 8

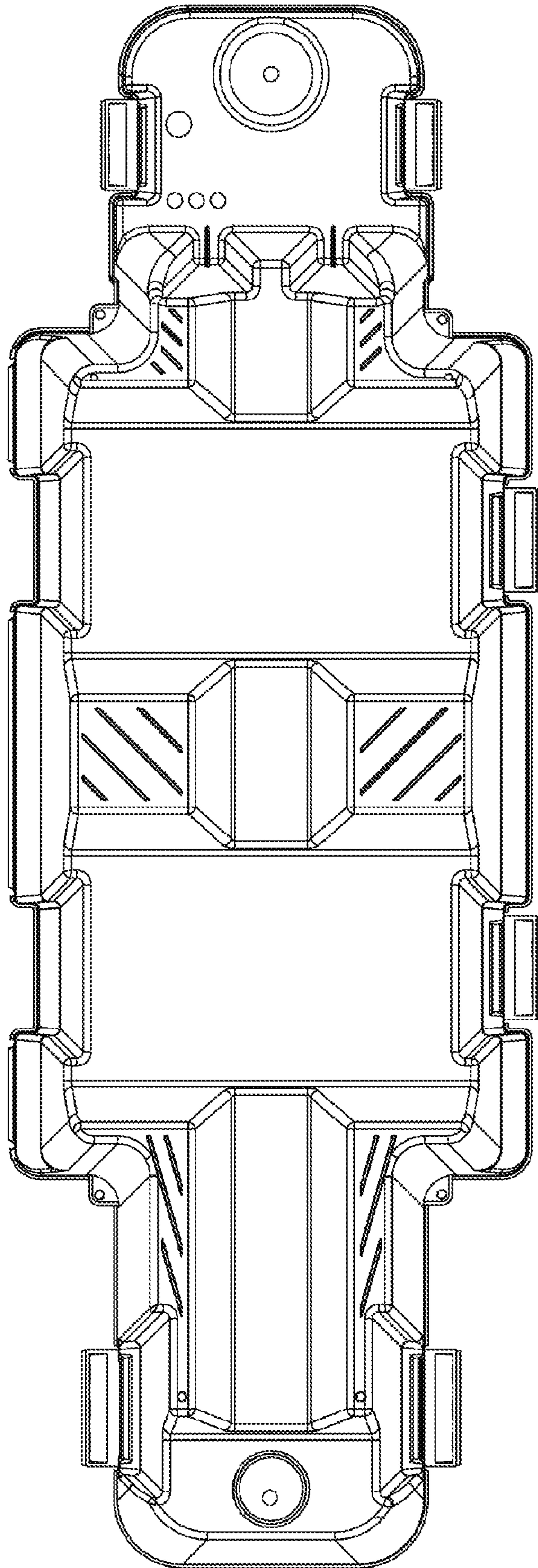

Fig. 9

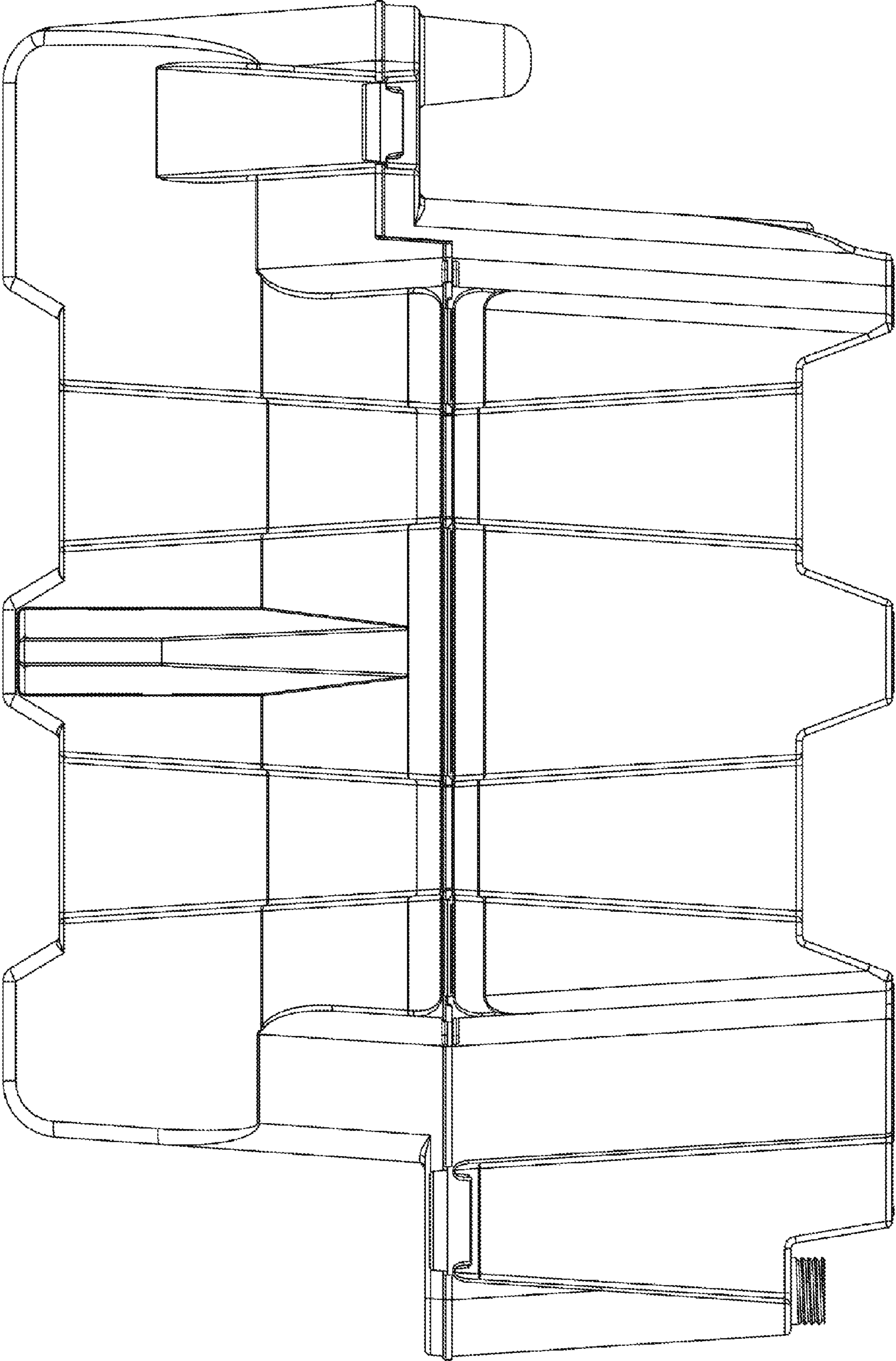

Fig. 10

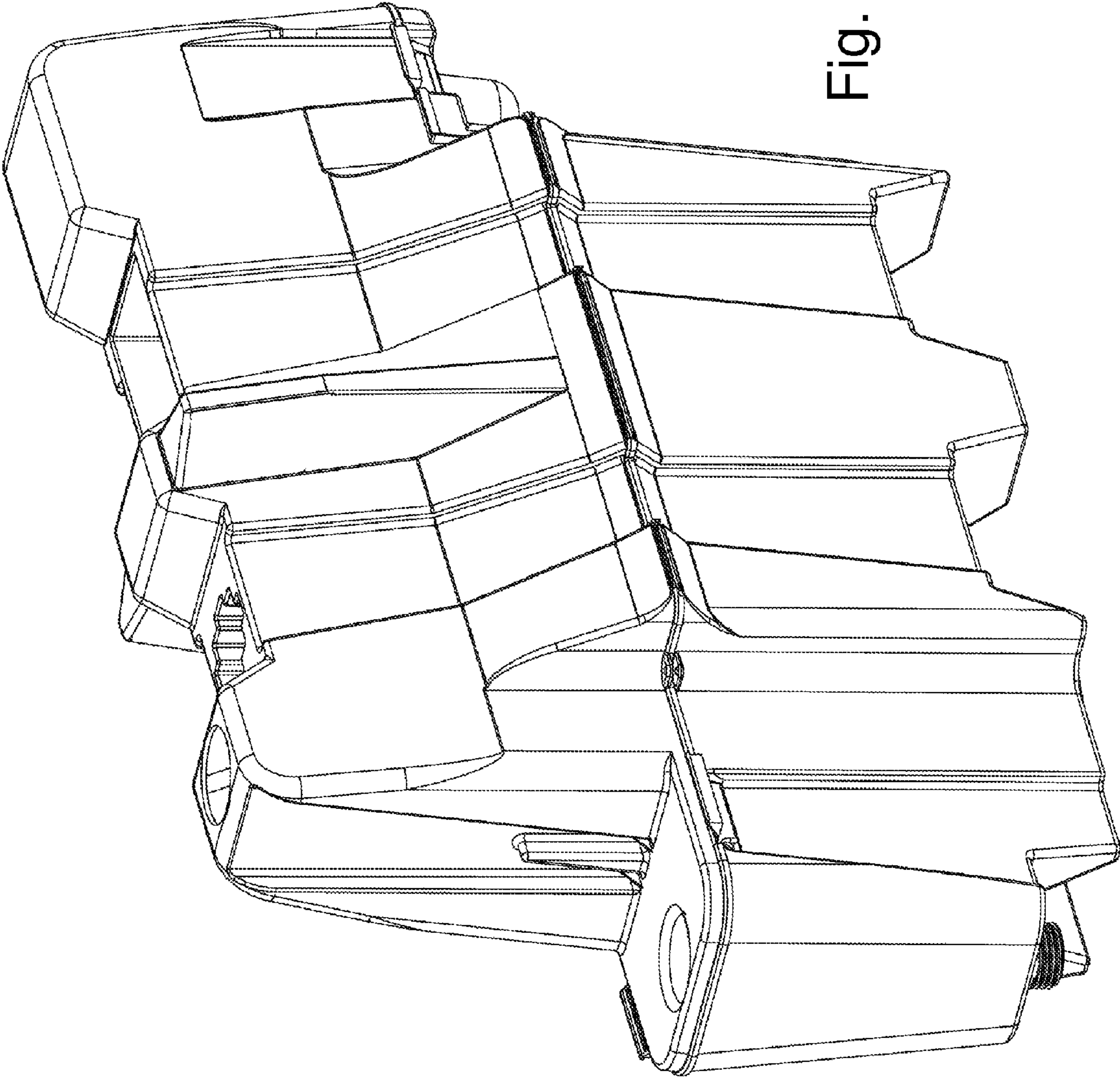

Fig. 11

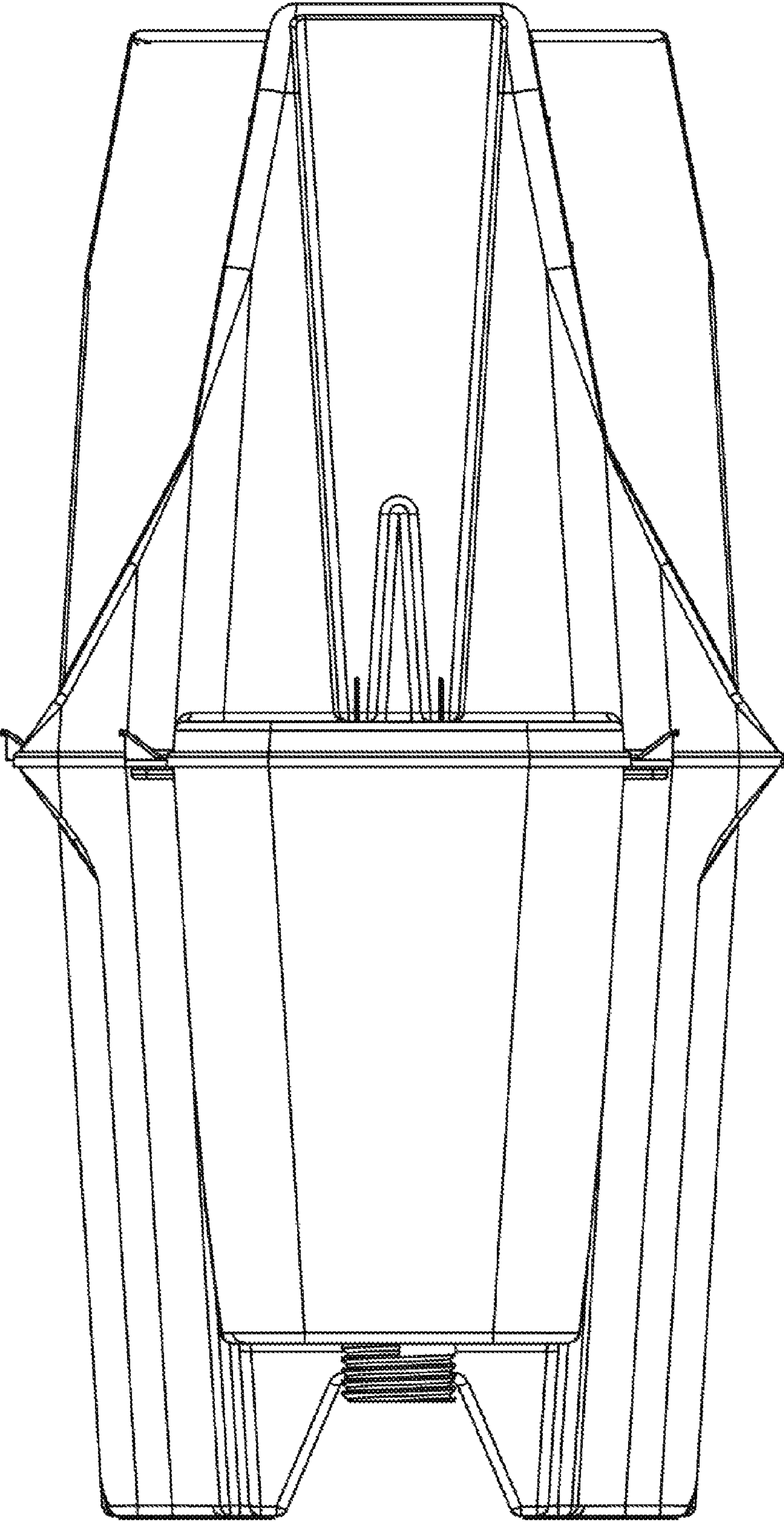

Fig. 12

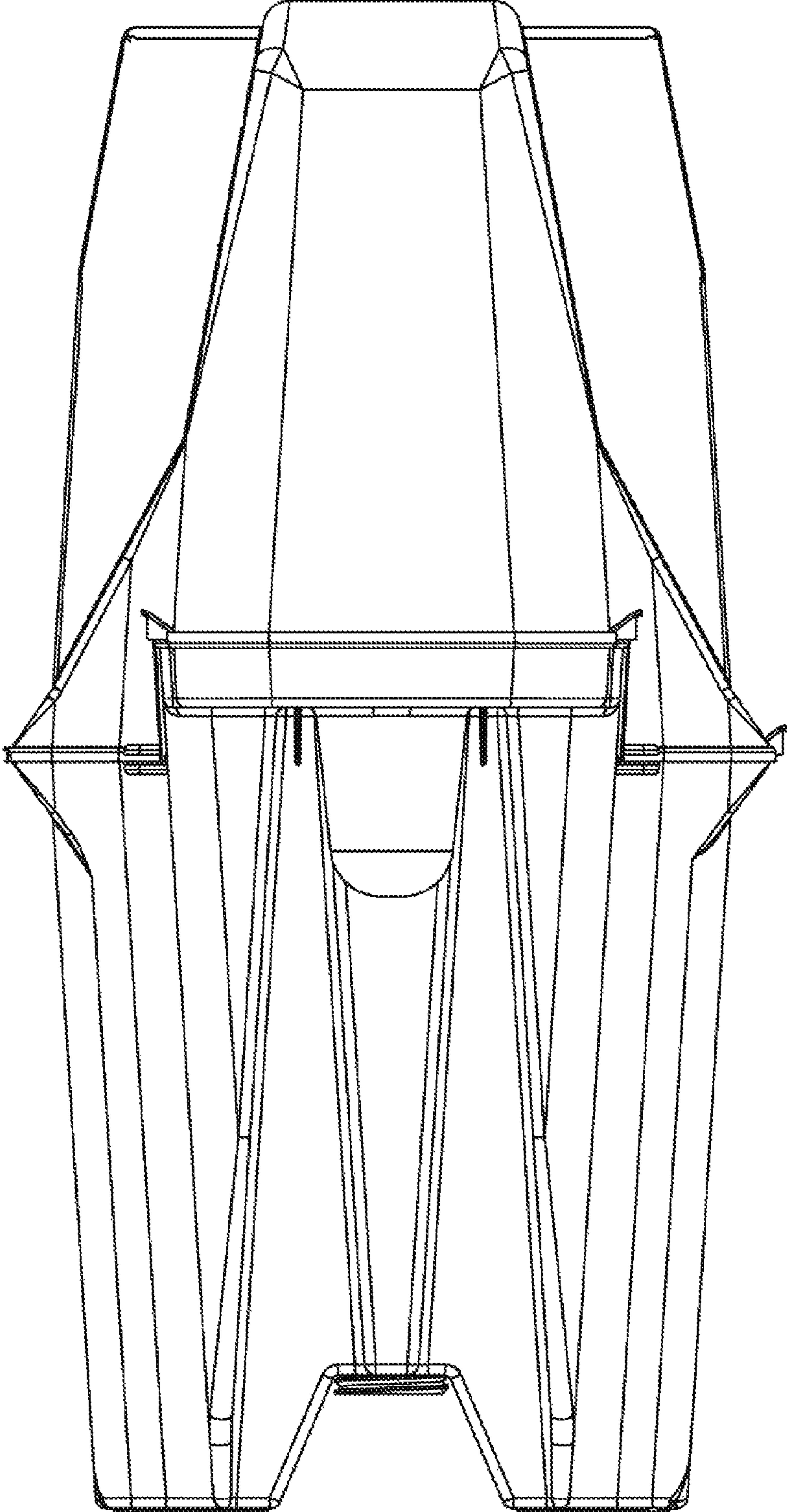

Fig. 13

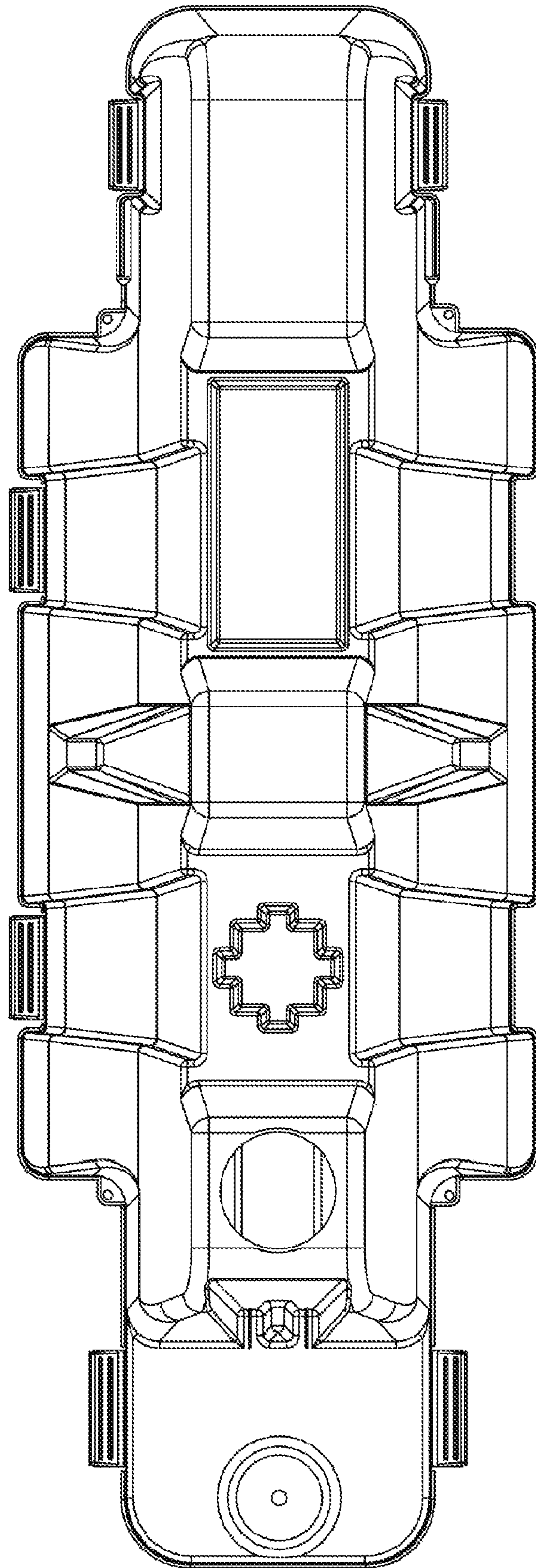

Fig. 14