



US00D629717S

(12) **United States Design Patent**
Artioli

(10) **Patent No.:** **US D629,717 S**
(45) **Date of Patent:** **** Dec. 28, 2010**

(54) **MOTOR CAR BODY**

D528,469 S * 9/2006 Yakushi et al. D12/90
D559,734 S * 1/2008 Sinkwitz D12/90

(75) Inventor: **Romano Artioli**, Luxembourg (LU)

* cited by examiner

(73) Assignee: **Automotive Research Technology & Style S.R.L.**, Trieste (TS) (IT)

Primary Examiner—Melody N Brown
(74) *Attorney, Agent, or Firm*—Notaro, Michalos & Zaccaria P.C.

(**) Term: **14 Years**

(21) Appl. No.: **29/326,590**

(57) **CLAIM**

(22) Filed: **Oct. 21, 2008**

The ornamental design for a motor car body, as shown and described.

(30) **Foreign Application Priority Data**

DESCRIPTION

Apr. 25, 2008 (EP) 000924626

Fig. 1 is a front, top, left perspective view of a motor car body showing my new design therefor, the broken line portions being environment only and forming no part of the design throughout the drawings;

(51) **LOC (9) Cl.** **12-08**

(52) **U.S. Cl.** **D12/91; D12/86**

(58) **Field of Classification Search** D12/86,
D12/90-92; D21/424, 433, 434; 296/181.1,
296/181.5

FIG. 2 is a left side elevational view thereof;
FIG. 3 is a right side elevational view thereof;
FIG. 4 is a rear elevational view thereof;
FIG. 5 is a front elevational view thereof;
FIG. 6 is a top plan view thereof;
FIG. 7 is a bottom plan view thereof; and,
FIG. 8 is a rear, top, right perspective view thereof.

See application file for complete search history.

(56) **References Cited**

1 Claim, 8 Drawing Sheets

U.S. PATENT DOCUMENTS

D442,119 S * 5/2001 Murata et al. D12/86
D495,275 S * 8/2004 Castiglione et al. D12/86
D515,458 S * 2/2006 Tolfsen et al. D12/85
D526,934 S * 8/2006 Fujiwara et al. D12/90

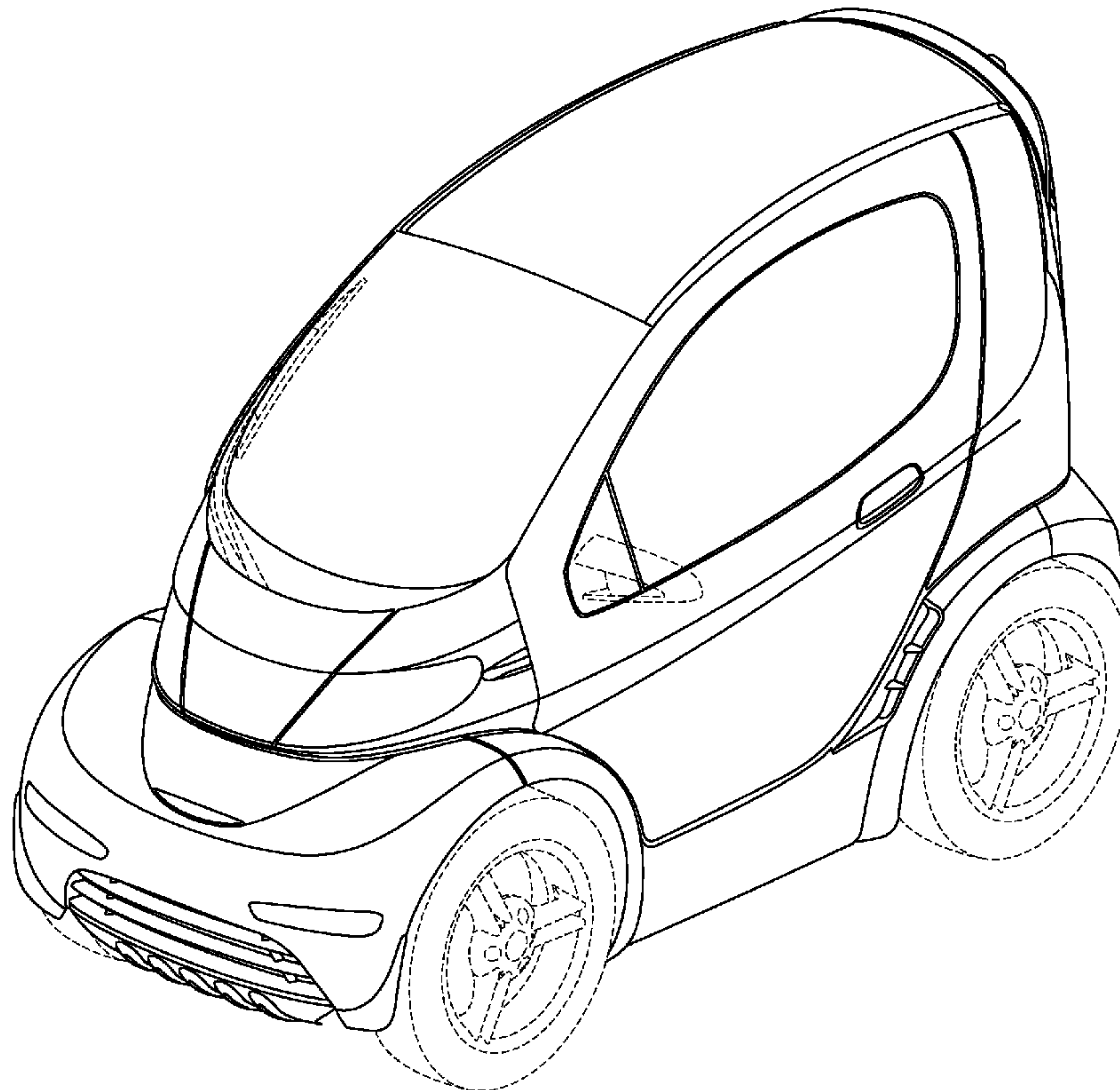

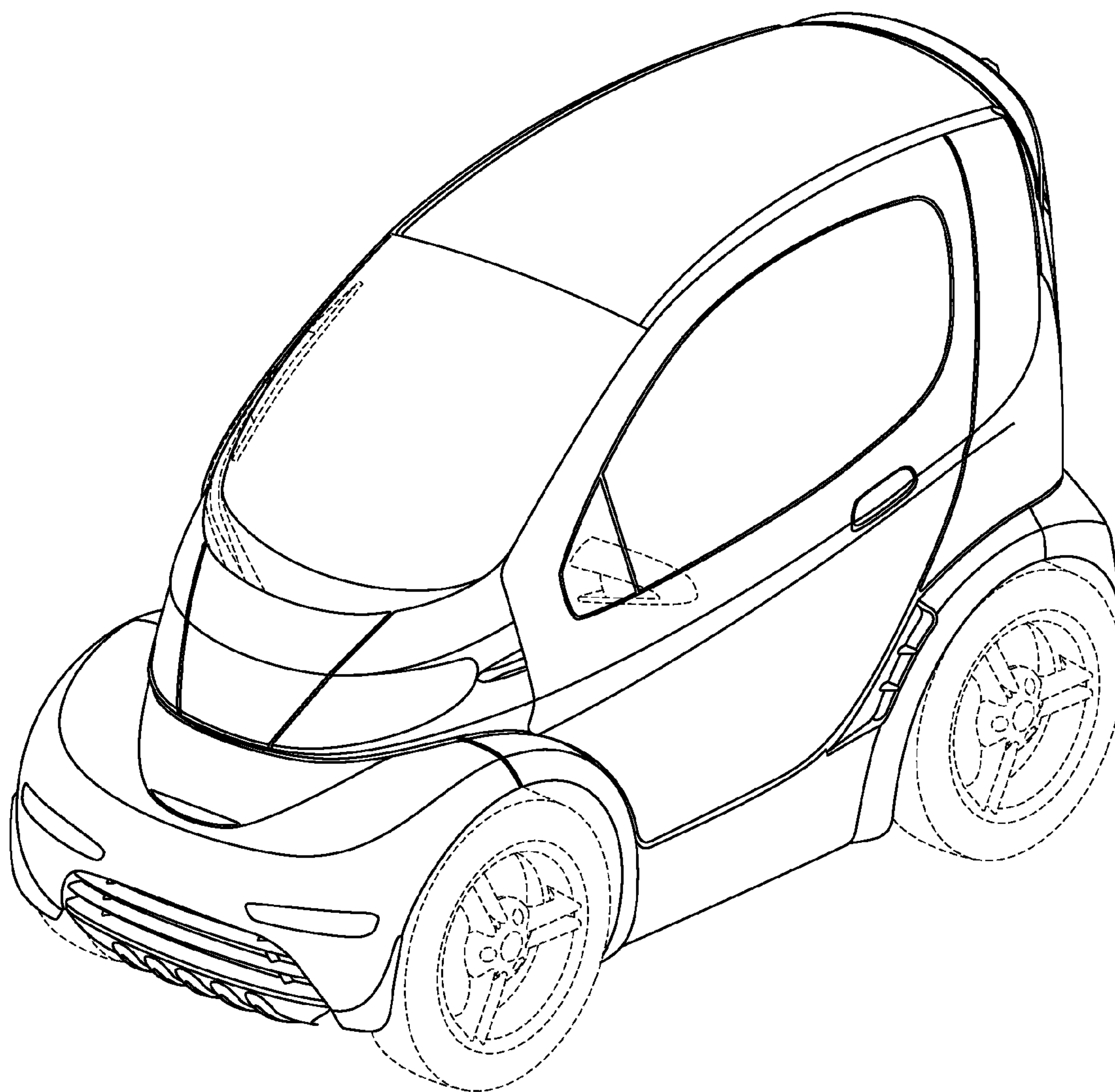

FIG. 1

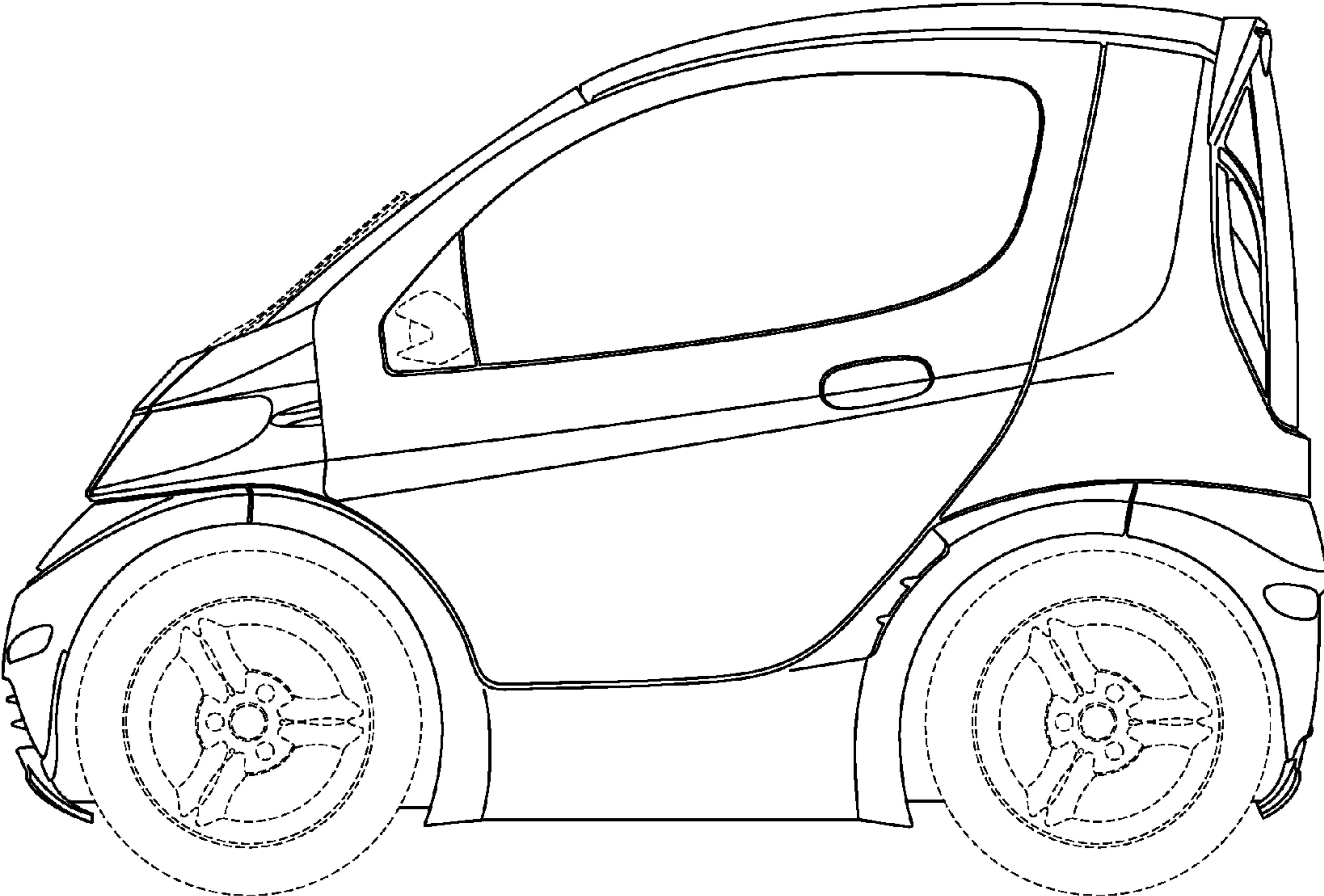

FIG. 2

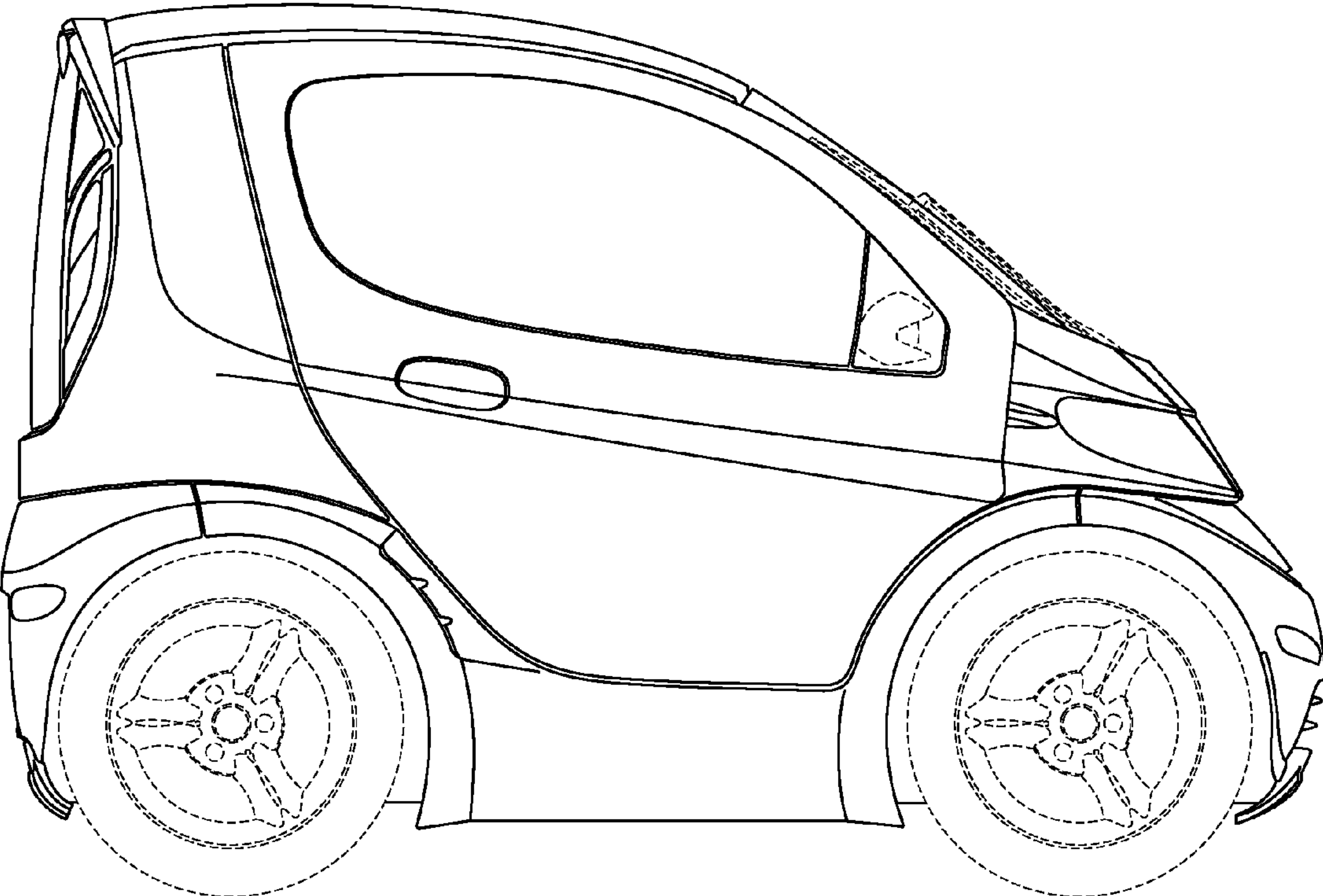

FIG. 3

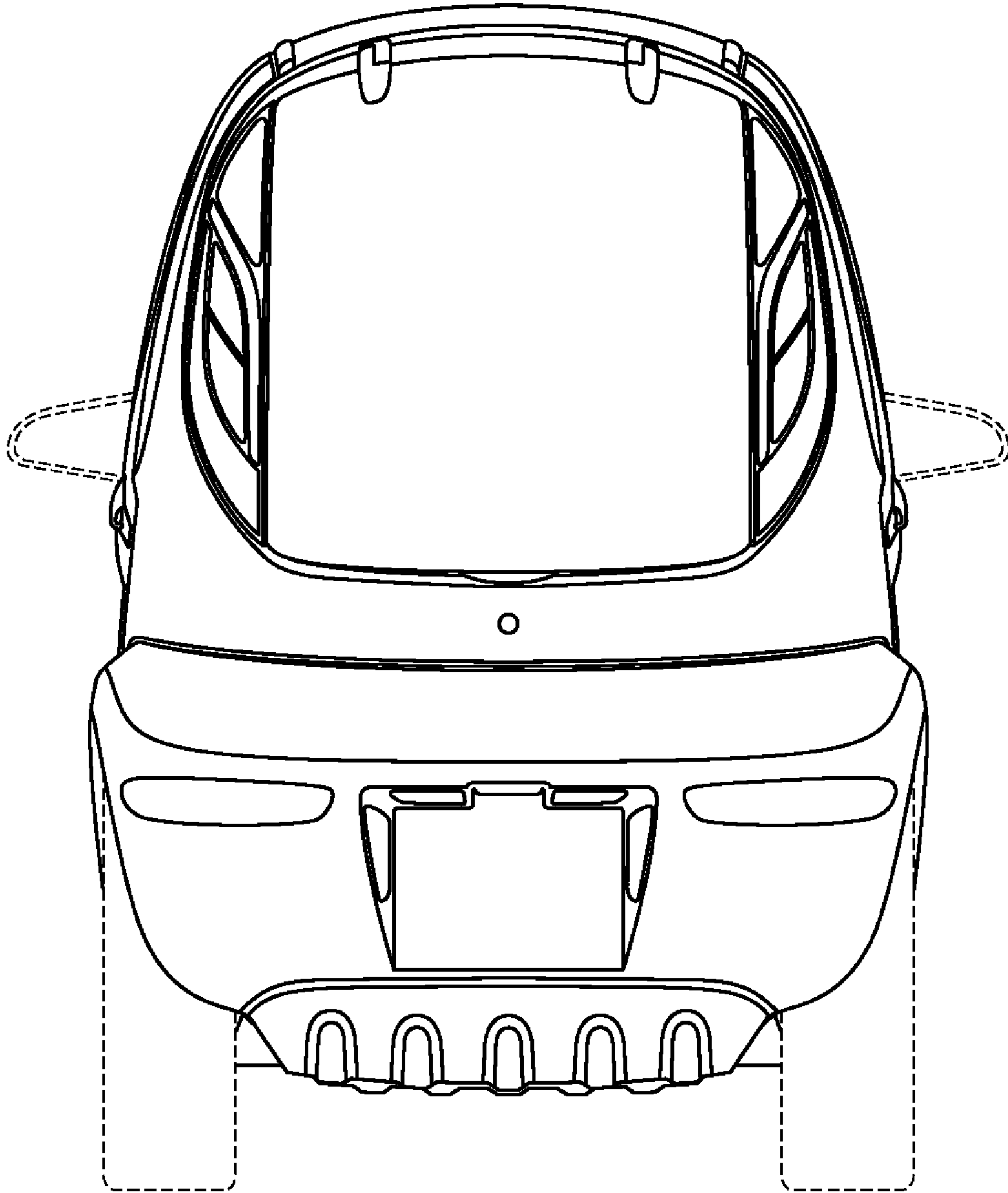

FIG. 4

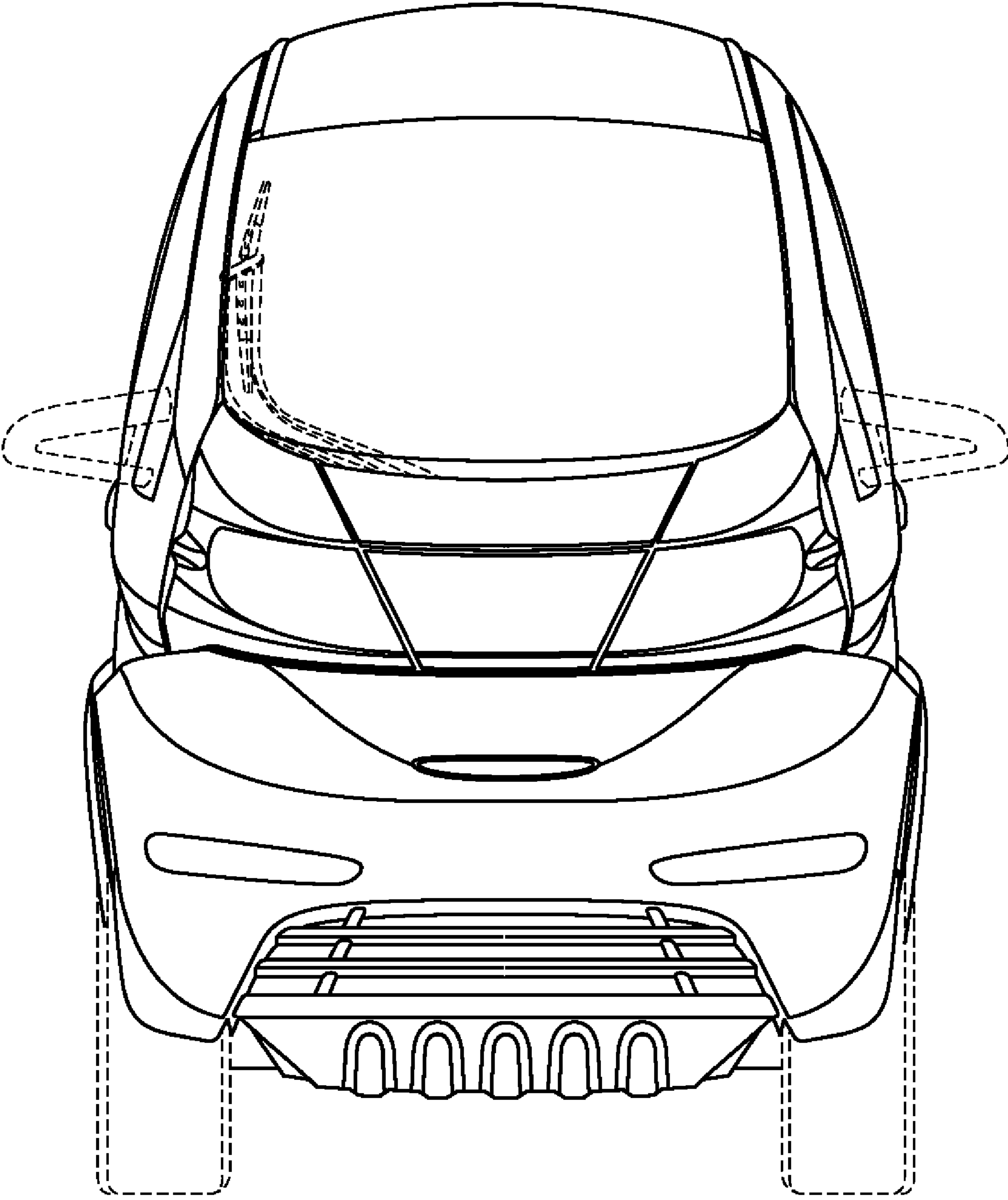

FIG. 5

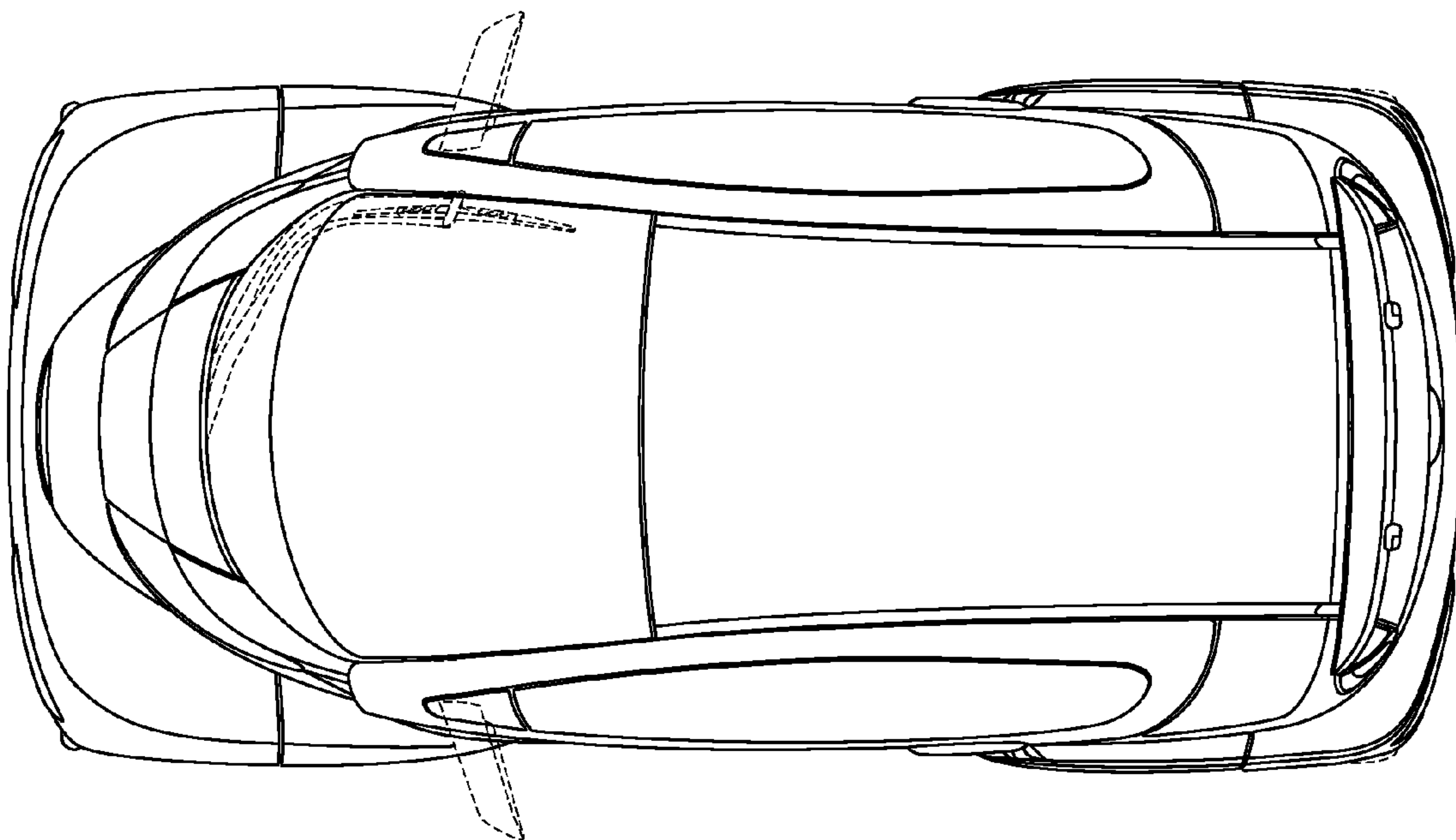

FIG. 6

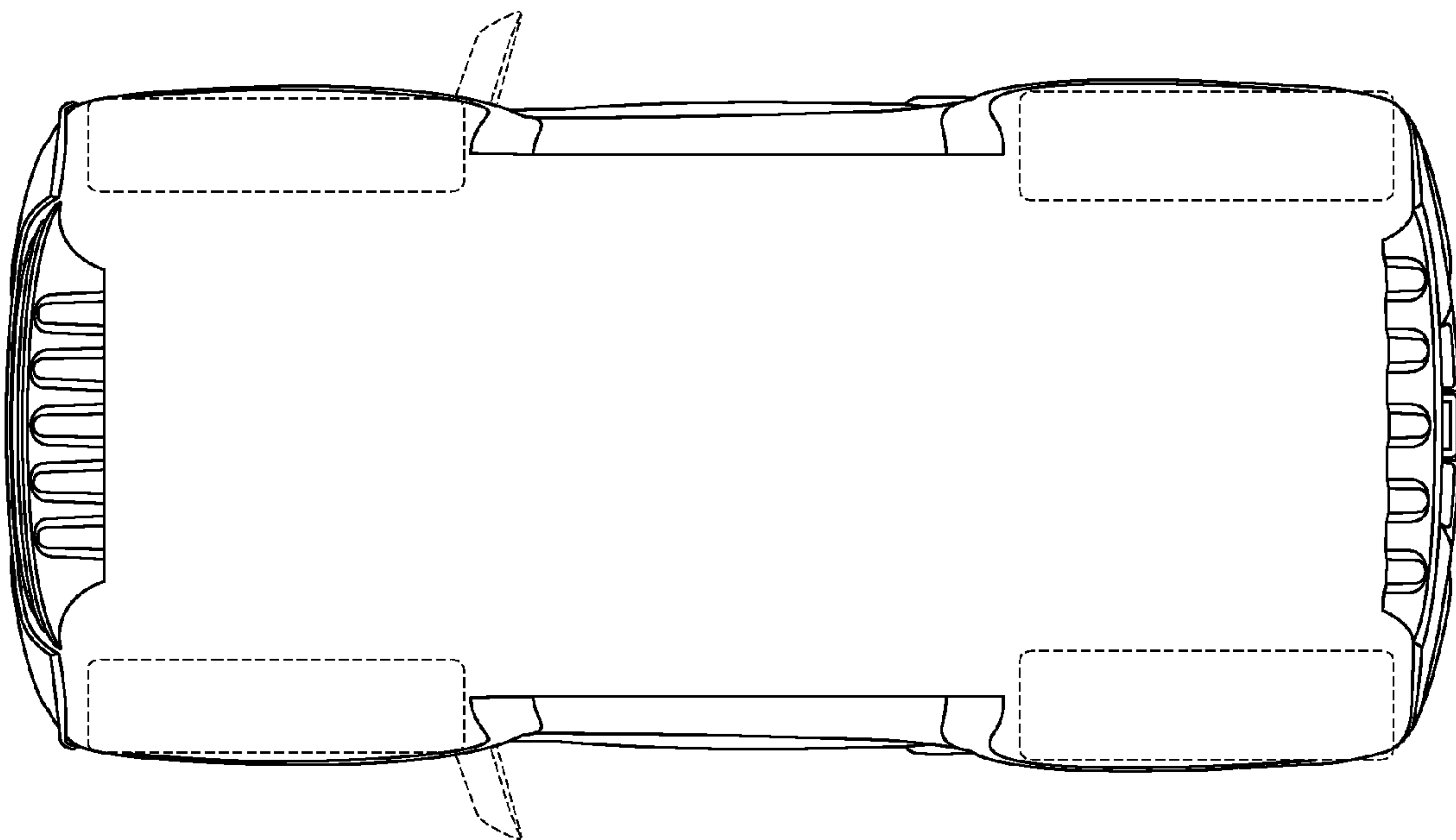

FIG. 7

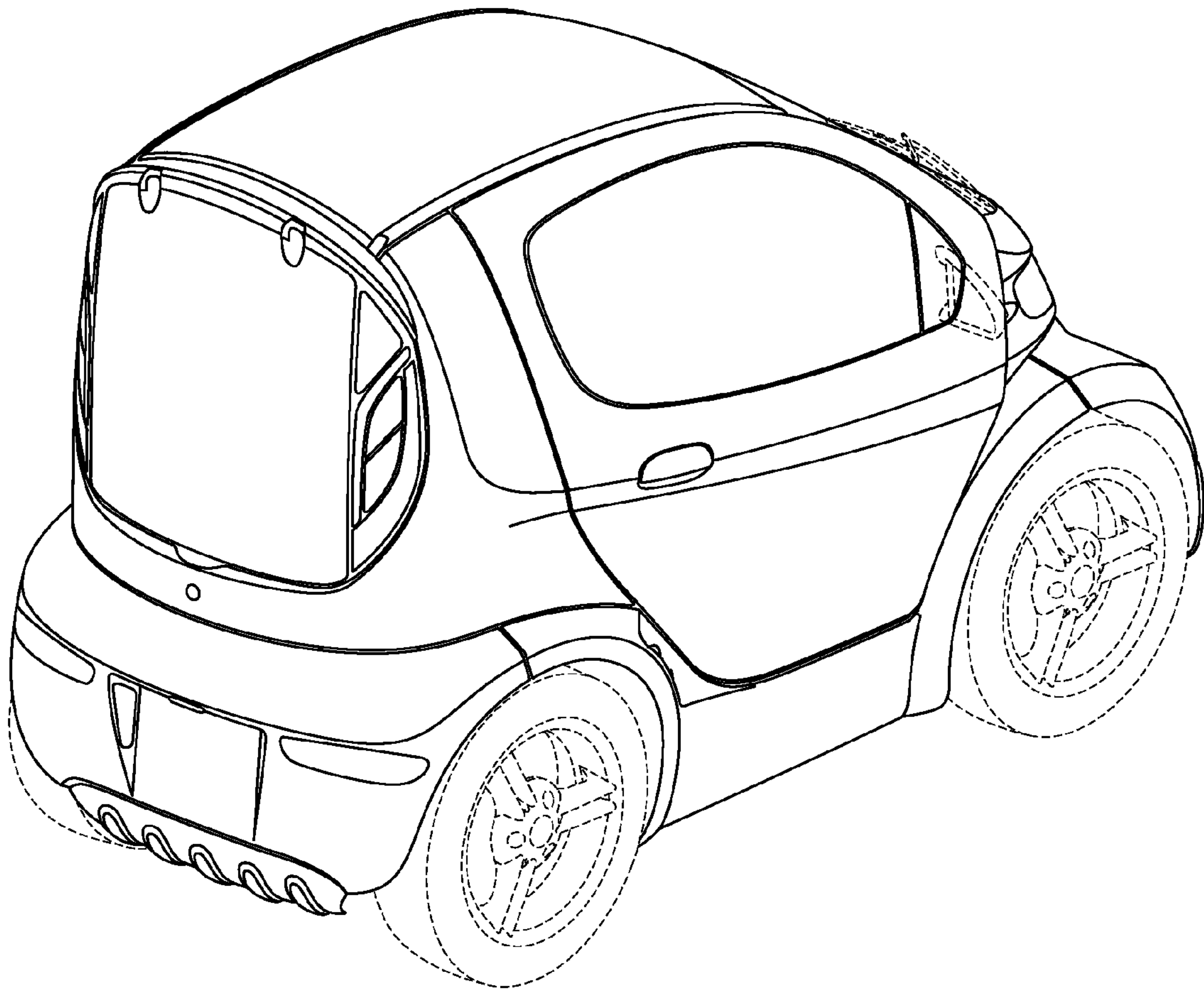

FIG. 8