



US00D629678S

(12) **United States Design Patent**
Norton et al.

(10) **Patent No.:** **US D629,678 S**
(45) **Date of Patent:** **** Dec. 28, 2010**

(54) **ANCHOR POST**

FOREIGN PATENT DOCUMENTS

(75) Inventors: **Ralph Edward Norton**, Launceston (AU); **Darran James Randall**, Youngtown (AU); **Scott Wesley Payton**, Launceston (AU); **Roger Clive Trethewie**, Launceston (AU)

AU	315070	4/2007
AU	318390	3/2008
AU	318391	3/2008
AU	318392	3/2008
AU	321552	10/2008

* cited by examiner

(73) Assignee: **Roadside Products Pty Ltd.**, Tasmania (AU)

Primary Examiner—Holly H Baynham

(74) *Attorney, Agent, or Firm*—Jon L. Woodard; MacDonald, Illig, Jones & Britton LLP

(**) Term: **14 Years**

(21) Appl. No.: **29/353,381**

(57) **CLAIM**

(22) Filed: **Jan. 7, 2010**

What is claimed the ornamental design for an anchor post, as shown and described.

(51) **LOC (9) Cl.** **08-08**

(52) **U.S. Cl.** **D8/388; D25/133**

(58) **Field of Classification Search** D8/388, D8/354; D21/840; D25/131, 133; 248/530, 248/156, 87; 52/153, 155, 704

See application file for complete search history.

DESCRIPTION

FIG. 1 is a top view of the anchor post of the invention;

FIG. 2 is a perspective view of the anchor post shown in FIG. 1;

FIG. 3 is an underside view of the anchor post shown in FIG. 1;

FIG. 4 is a front view of the anchor post shown in FIG. 1;

FIG. 5 is a side view of the anchor post shown in FIG. 1; and,

FIG. 6 is a rear view of the anchor post shown in FIG. 1.

(56) **References Cited**

U.S. PATENT DOCUMENTS

1,257,215	A *	2/1918	Greene	248/530
D422,897	S *	4/2000	Blackwell	D8/388
D492,976	S *	7/2004	Hsu	D21/840
D493,205	S *	7/2004	Combes	D21/840

1 Claim, 2 Drawing Sheets

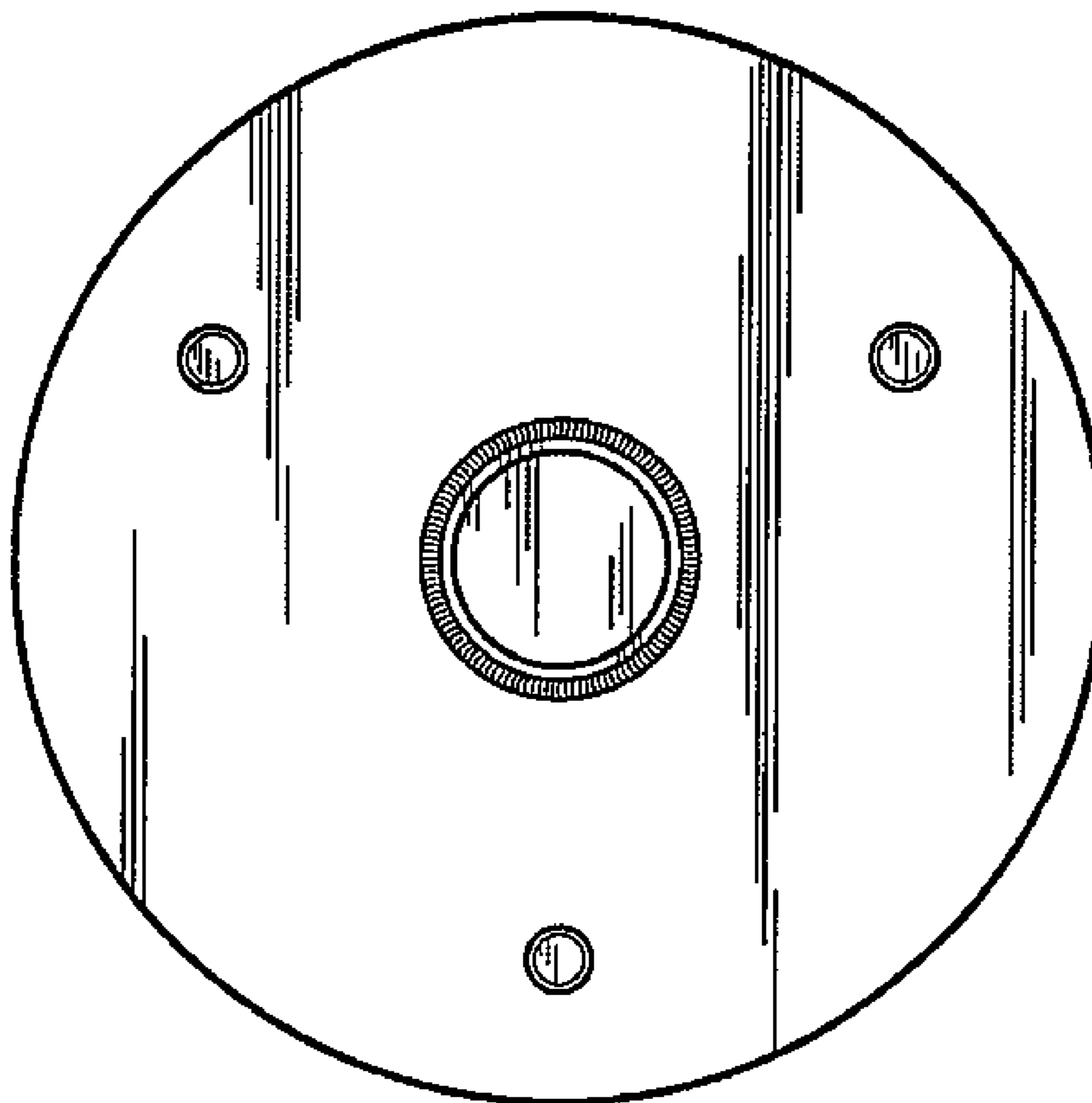

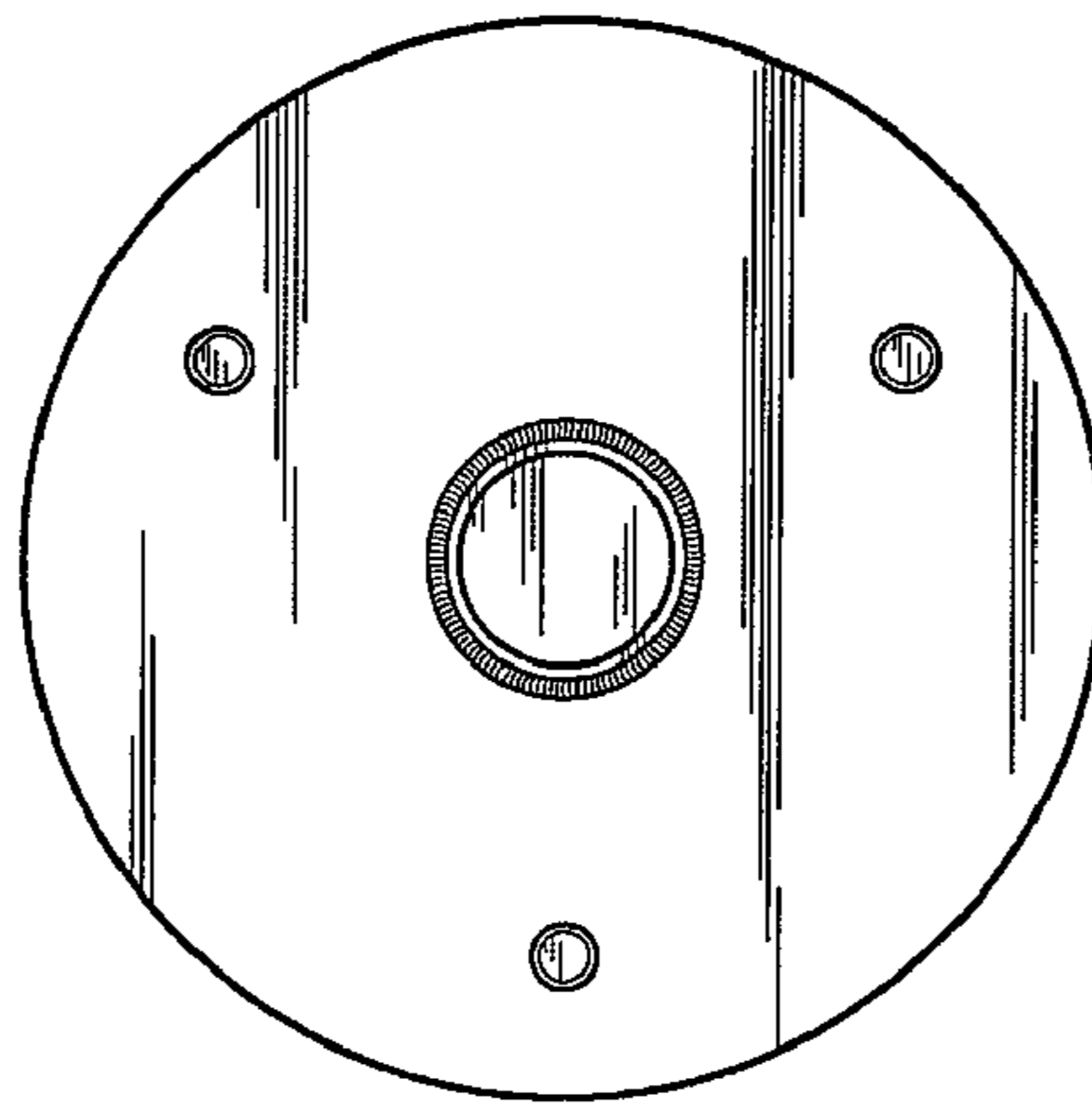

Fig 1

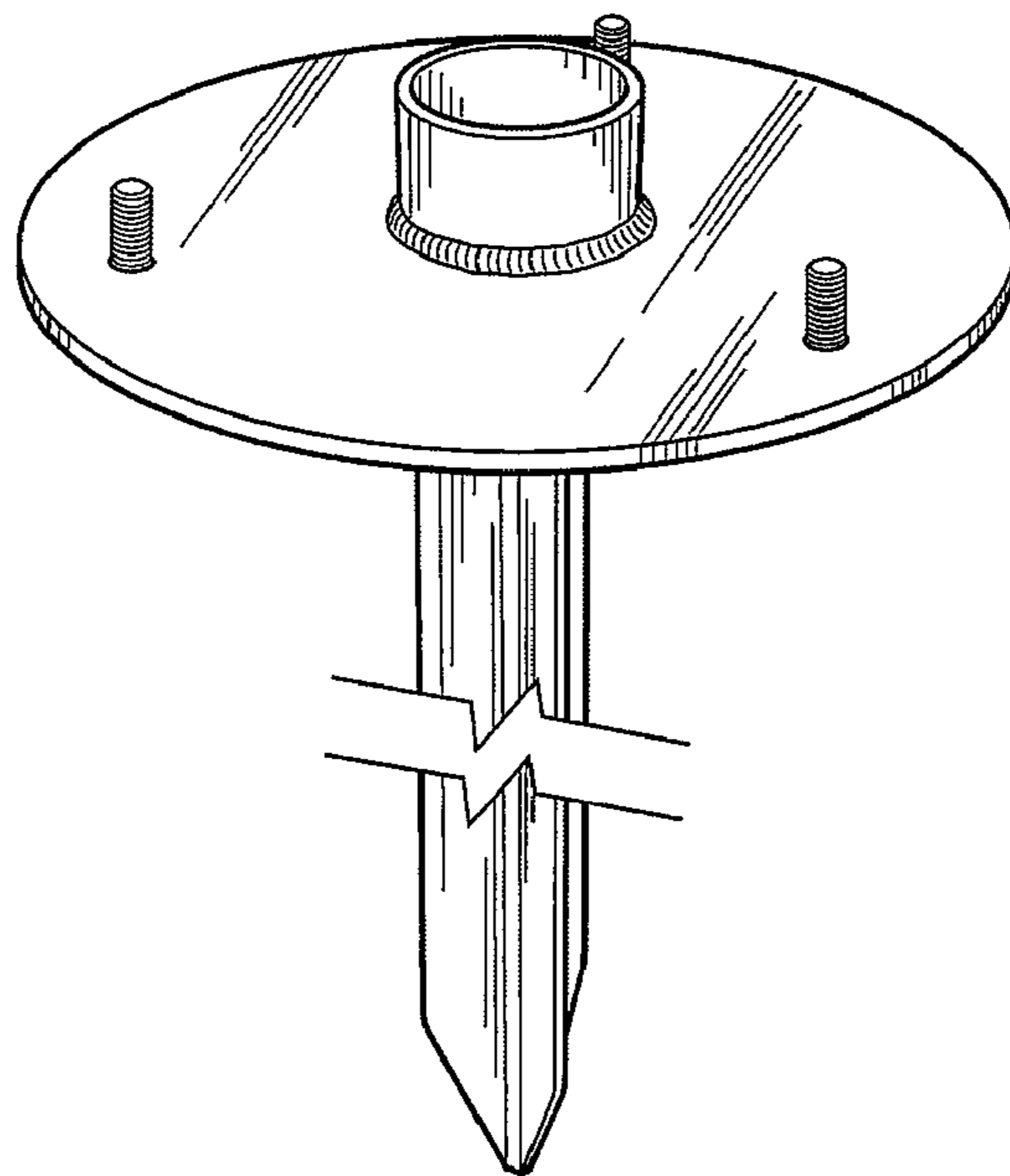

Fig 2

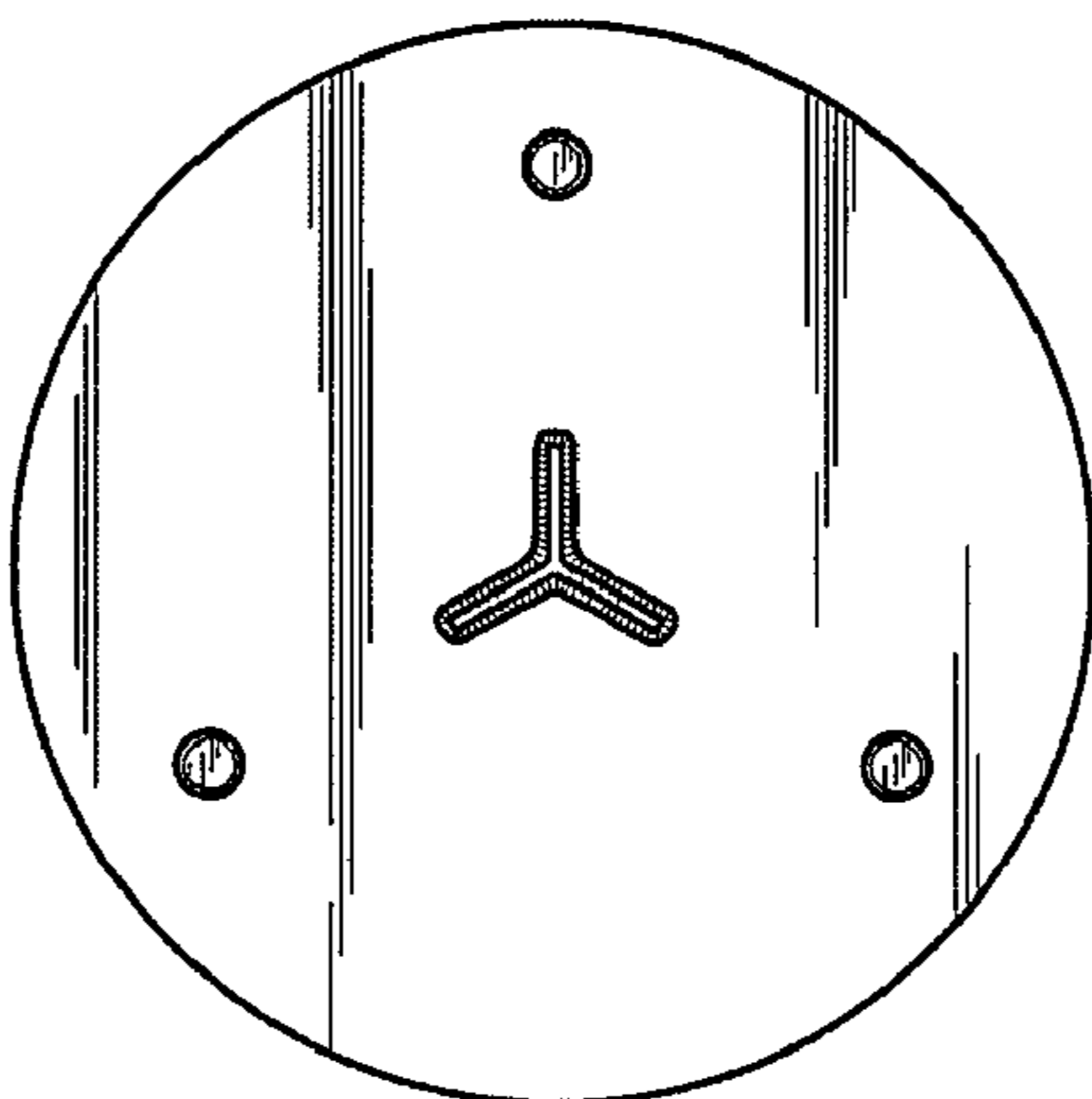

Fig 3

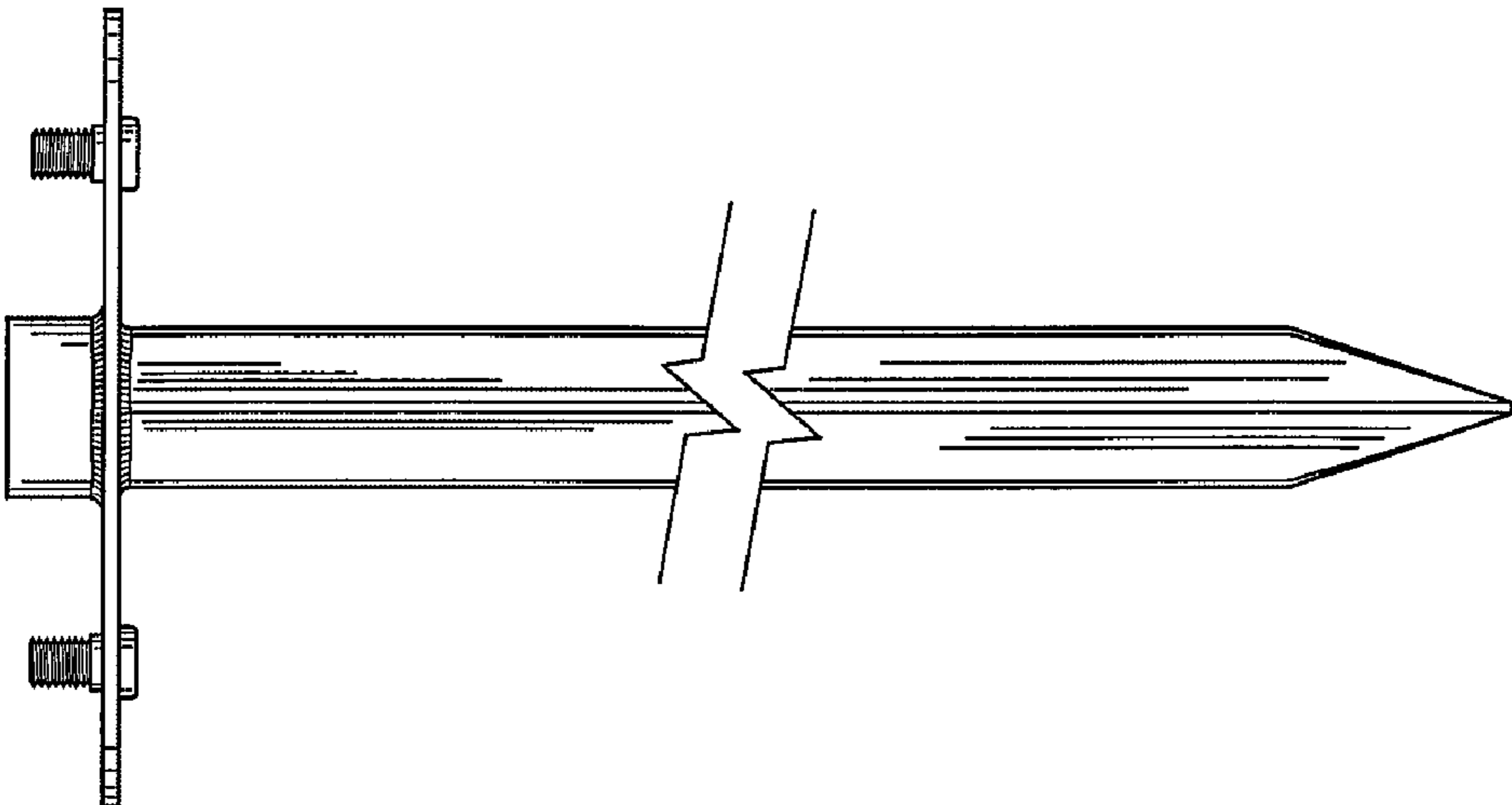

Fig 6

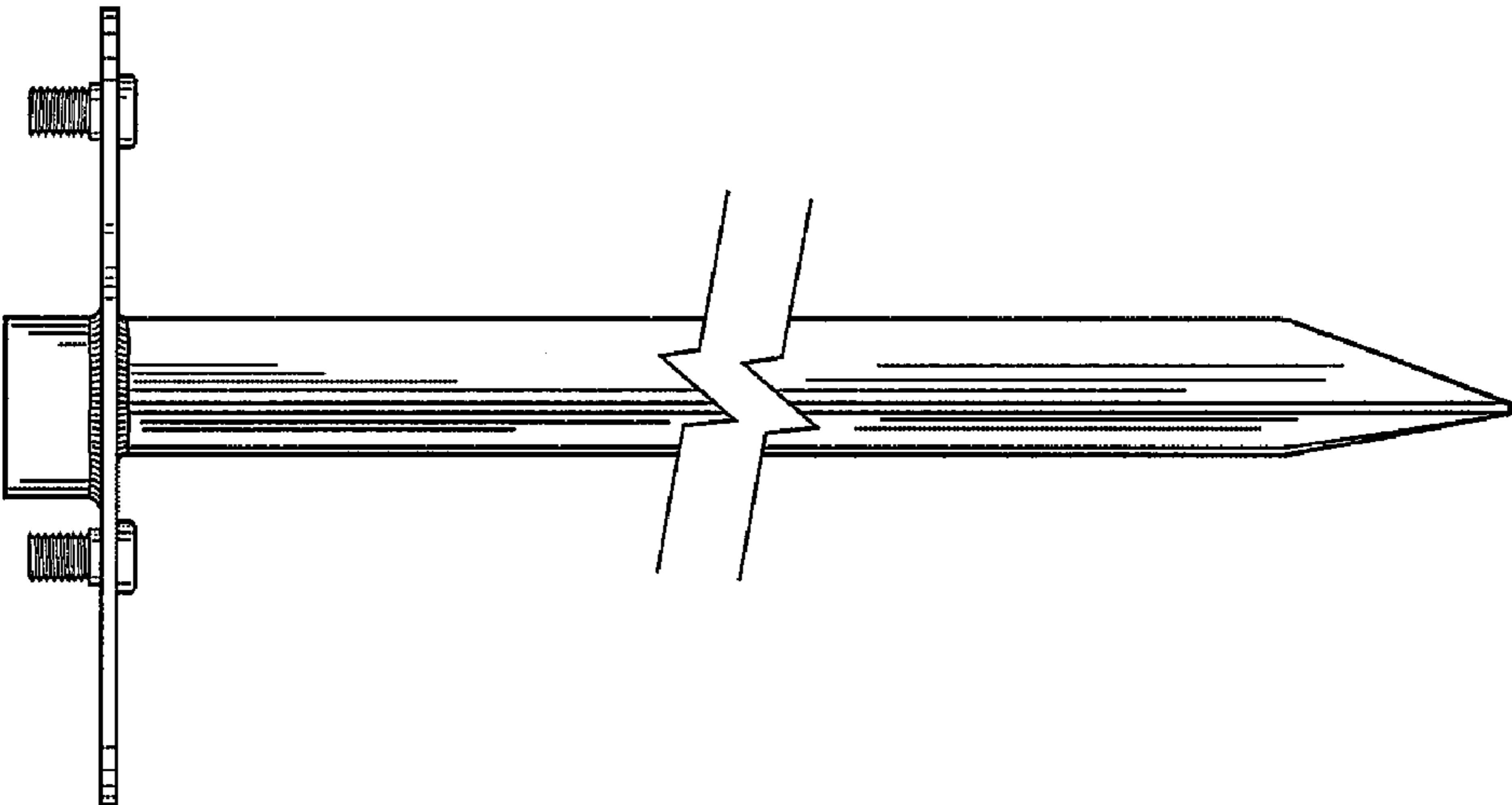

Fig 5

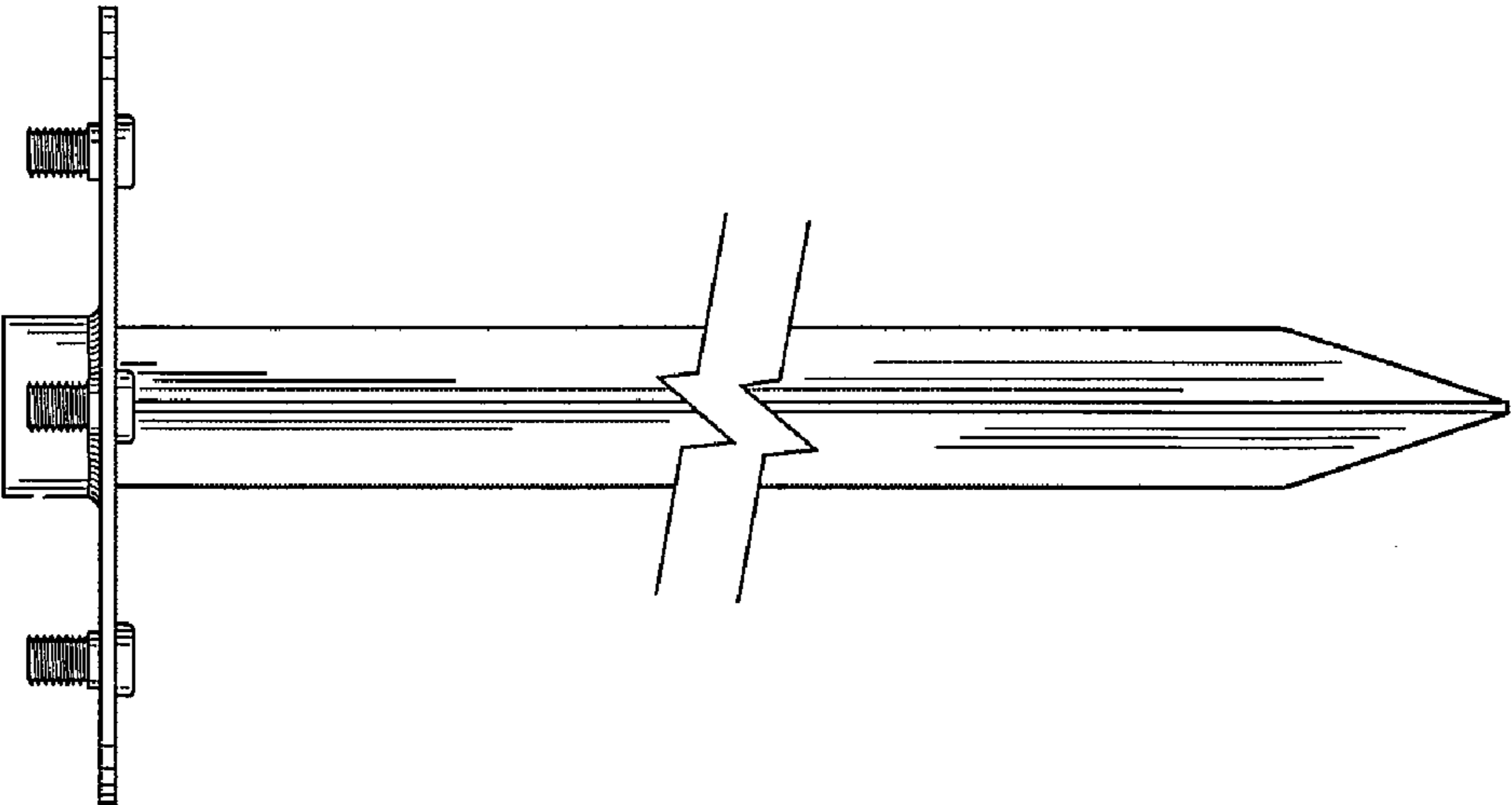

Fig 4