



US00D629677S

(12) **United States Design Patent**  
**Sochko**

(10) **Patent No.:** **US D629,677 S**

(45) **Date of Patent:** **\*\* Dec. 28, 2010**

(54) **STATIC WEAPON MOUNT WITH ELECTRIC LOCK**

*Primary Examiner*—Holly H Baynham  
(74) *Attorney, Agent, or Firm*—McHale & Slavin, P.A.

(76) **Inventor:** **Michael C. Sochko**, 233 Beverly Rd.,  
West Palm Beach, FL (US) 33405

(57) **CLAIM**

The ornamental design for a static weapon mount with electric lock, as shown and described.

(\*\*) **Term:** **14 Years**

(21) **Appl. No.:** **29/353,336**

**DESCRIPTION**

(22) **Filed:** **Jan. 7, 2010**

FIG. 1 is a top perspective view of the static weapon mount with electric lock of the instant invention;

(51) **LOC (9) Cl.** ..... **08-05**

FIG. 2 is a top view thereof;

(52) **U.S. Cl.** ..... **D8/380; 363/373**

FIG. 3 is a bottom view thereof;

(58) **Field of Classification Search** ..... D8/373,  
D8/363, 349, 354, 343, 380; D22/109–110;  
362/110, 113–114; 42/114, 146

FIG. 4 is a left side view thereof;

FIG. 5 is a right side view thereof;

See application file for complete search history.

FIG. 6 is a front side view thereof;

FIG. 7 is a rear side view thereof; and,

(56) **References Cited**

**U.S. PATENT DOCUMENTS**

FIG. 8 is a reduced scale front perspective view illustrating the static weapon mount with electric lock secured to the inner surface of a vehicle trunk lid.

3,880,389	A *	4/1975	Burris	.....	248/205.1
D239,114	S *	3/1976	Kraal	.....	D22/109
D573,443	S *	7/2008	Swan	.....	D8/343
D600,312	S *	9/2009	Swan	.....	D22/109

The portions of drawings illustrated by broken lines are for illustrative purposes and form no part of the claimed design.

\* cited by examiner

**1 Claim, 6 Drawing Sheets**

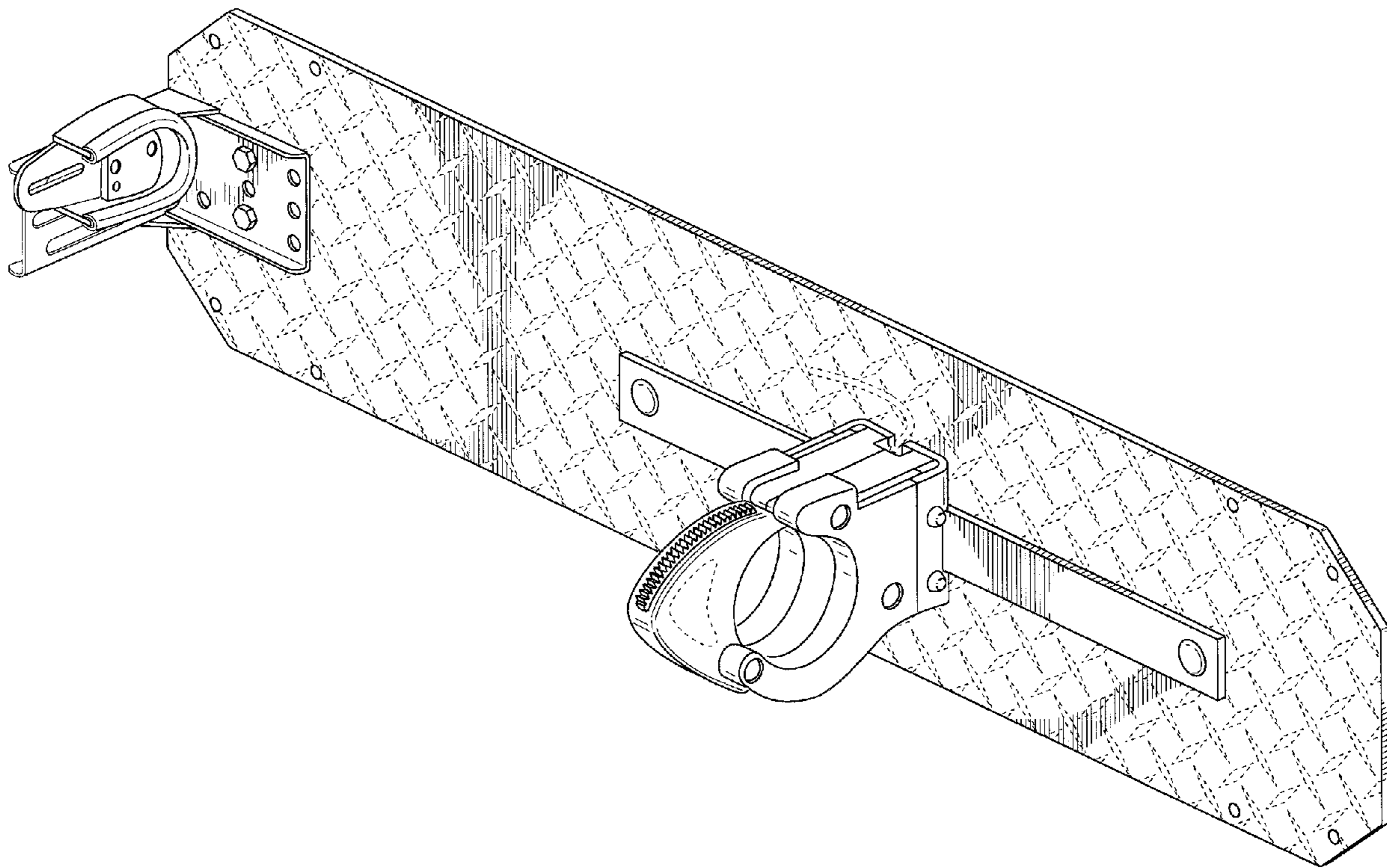

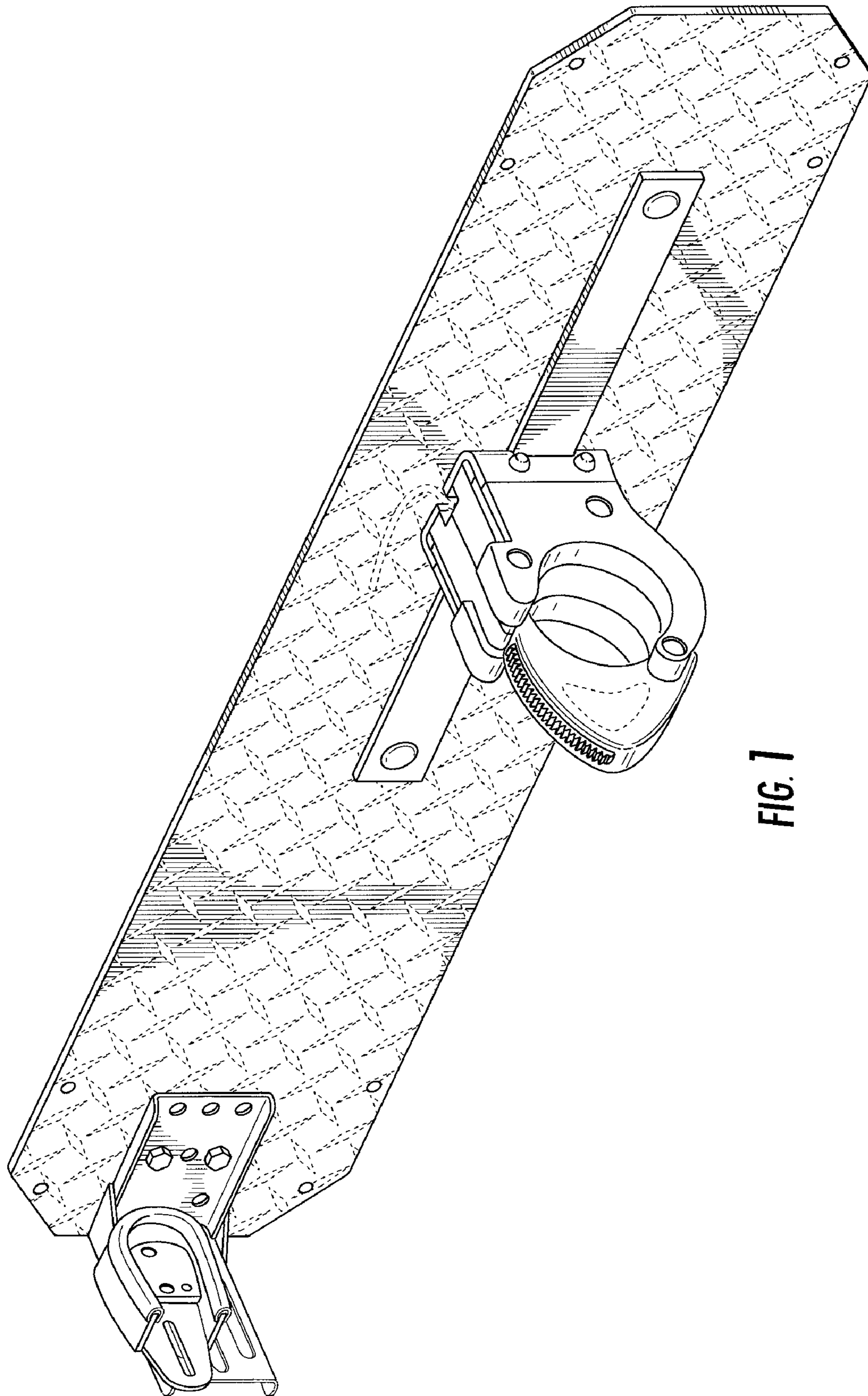

FIG. 1

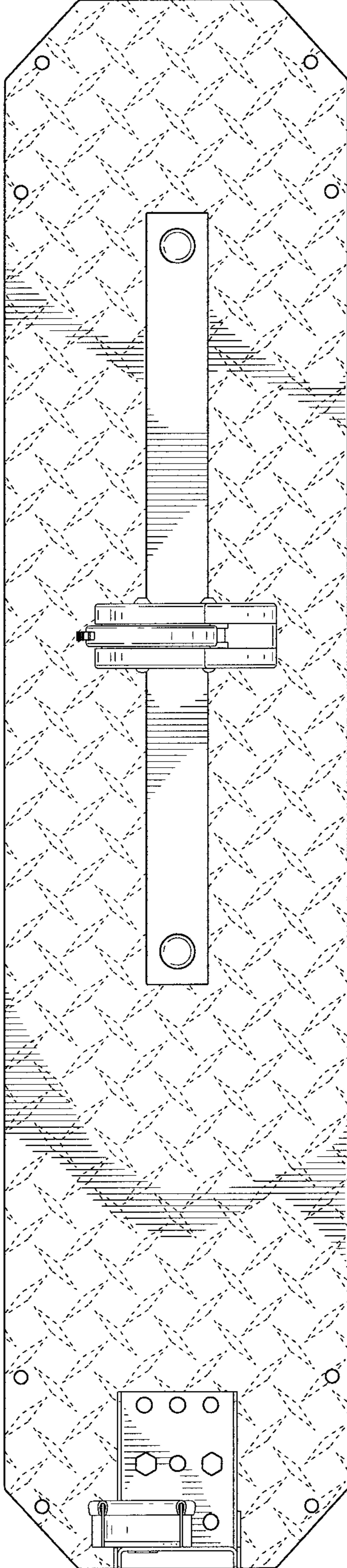

FIG. 2

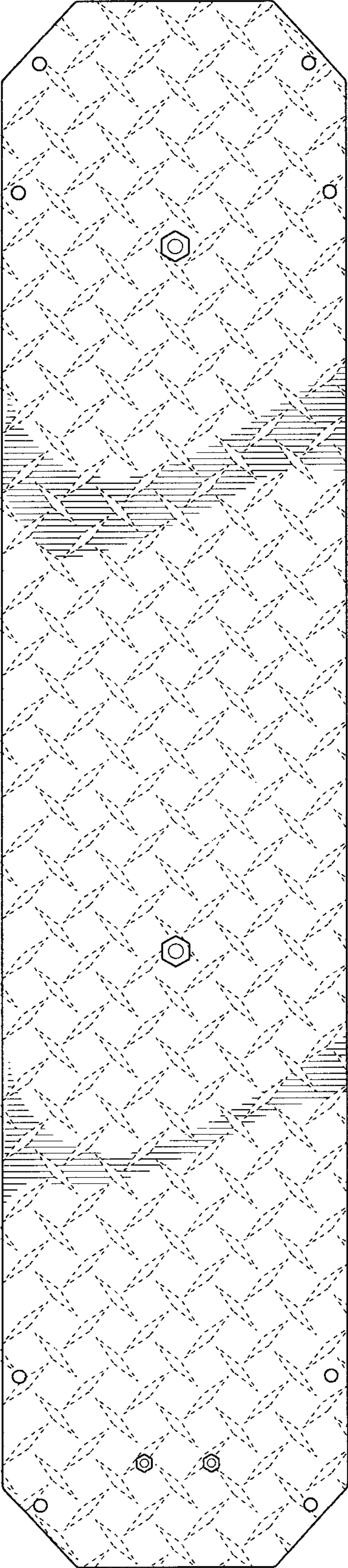
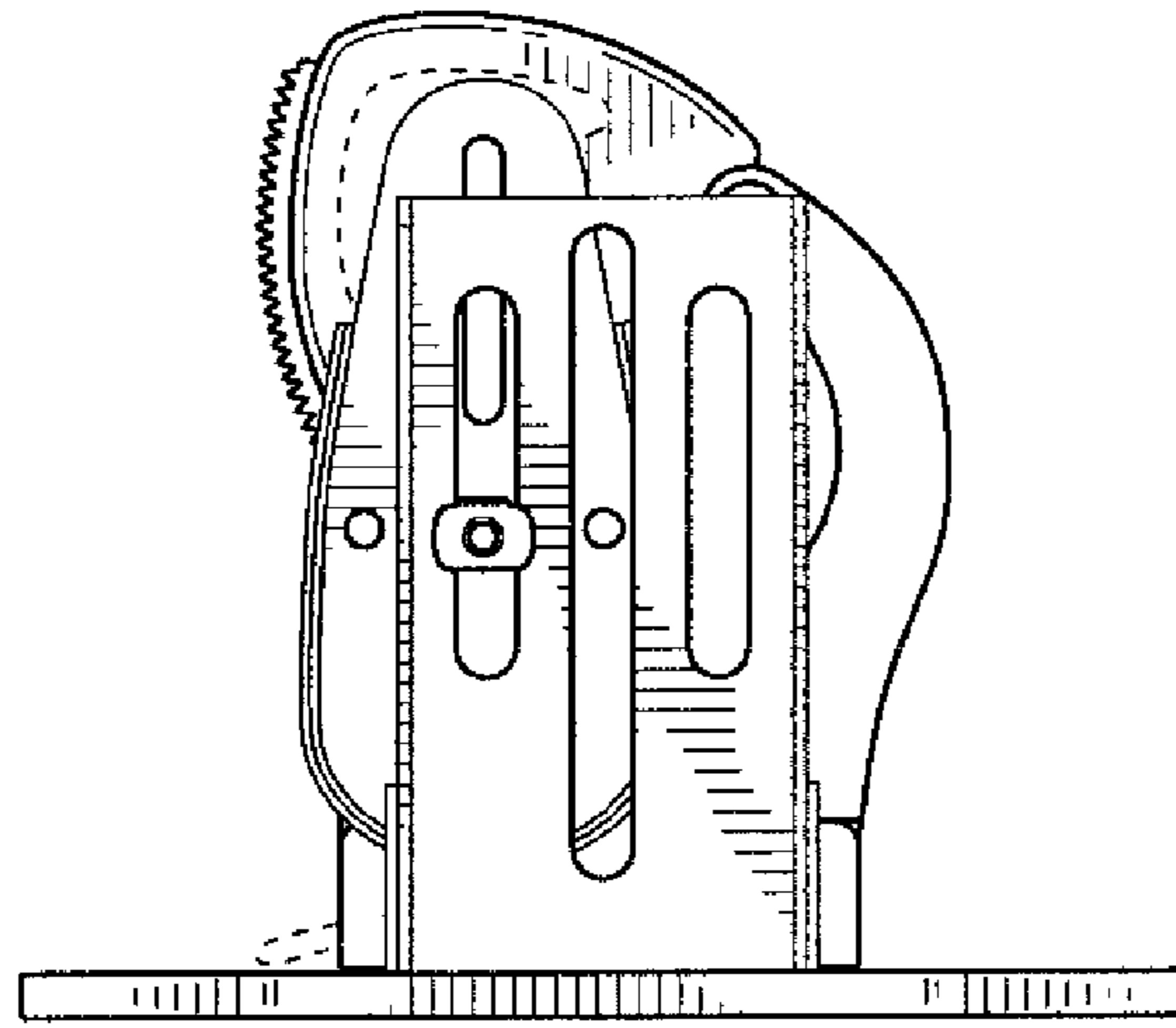
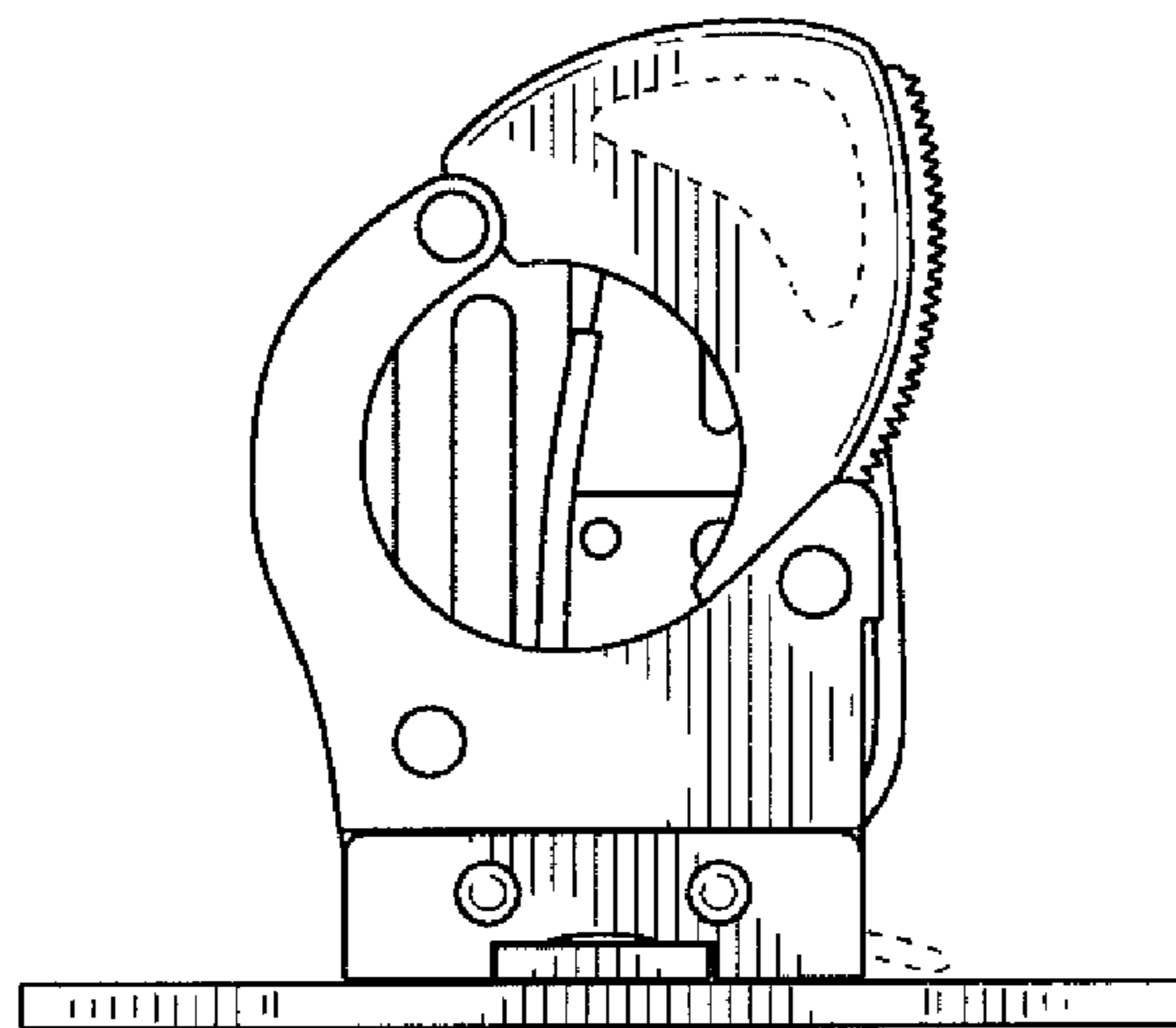

FIG. 3



**FIG. 4**



**FIG. 5**

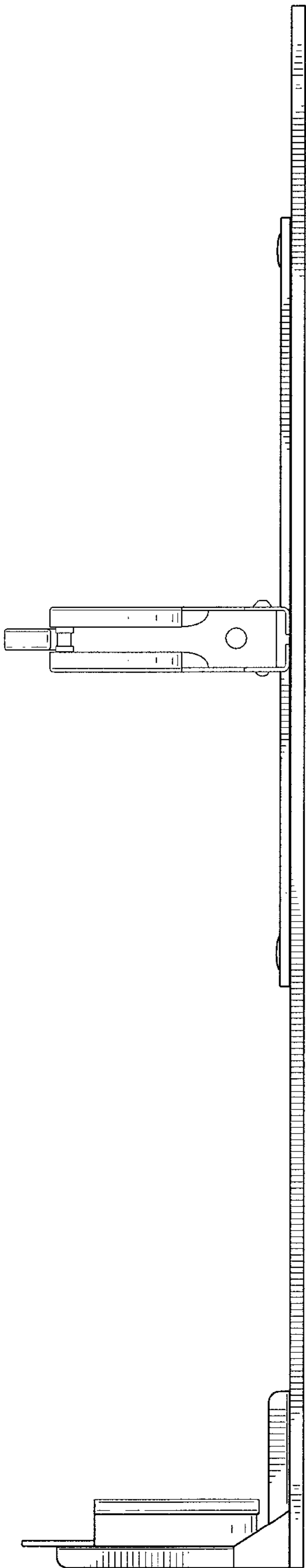

FIG. 6

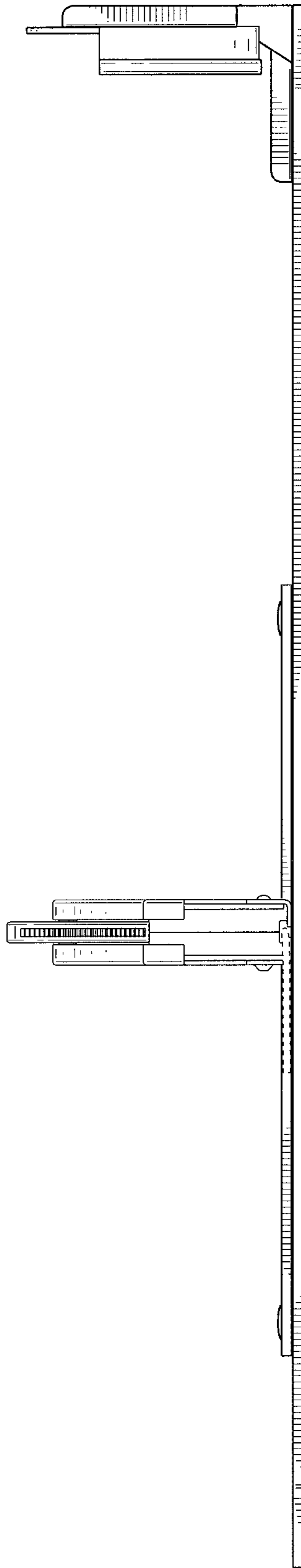

FIG. 7

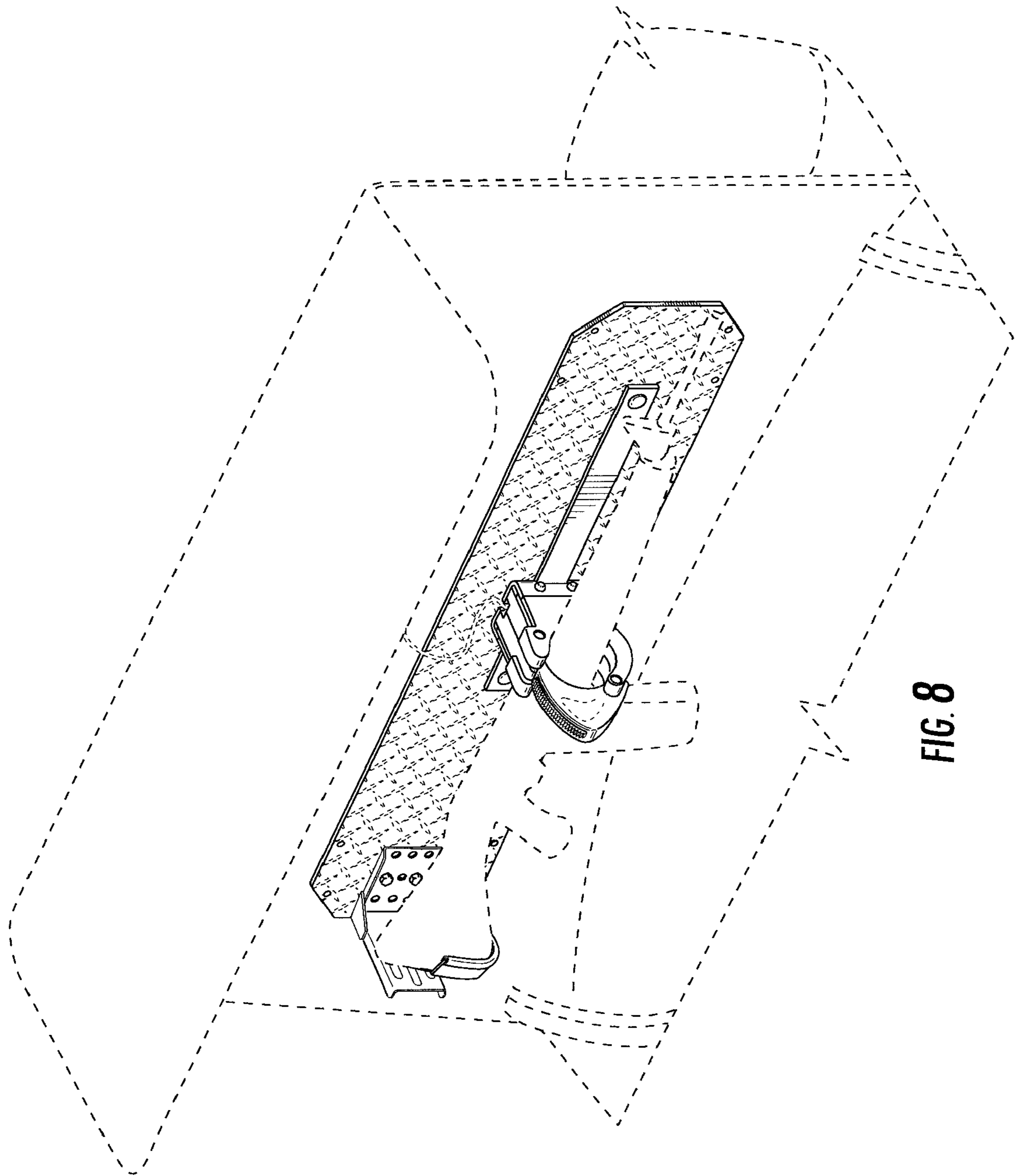

FIG. 8