



US00D629625S

(12) **United States Design Patent**
Daley

(10) **Patent No.:** **US D629,625 S**

(45) **Date of Patent:** **** Dec. 28, 2010**

(54) **BOOSTER SEAT**

(75) Inventor: **Richard A. Daley**, Santa Rosa Beach,
FL (US)

(73) Assignee: **BRICA, Inc.**, Freeport, FL (US)

(**) Term: **14 Years**

(21) Appl. No.: **29/362,655**

(22) Filed: **May 28, 2010**

(51) **LOC (9) Cl.** **06-01**

(52) **U.S. Cl.** **D6/333**

(58) **Field of Classification Search** D6/333,
D6/335, 491, 339, 500–502, 368, 375, 334;
5/94, 98.1; 297/183.1, 250.1, 256.1, 423.41,
297/440.1, 440.12–440.19, 216, 467, 17 CS
See application file for complete search history.

(56) **References Cited**

U.S. PATENT DOCUMENTS

4,092,049	A *	5/1978	Schoblom	297/440.23
D283,855	S *	5/1986	Kujawski	D6/333
4,828,281	A *	5/1989	Sanchas	280/30
D314,674	S *	2/1991	Kohus et al.	D6/333
D334,848	S *	4/1993	Mariol	D6/333
D337,210	S *	7/1993	Silverman	D6/333
D357,129	S *	4/1995	Tiramani	D6/336
D360,308	S *	7/1995	Smith et al.	D6/333
D369,493	S *	5/1996	LaRoche	D6/334
D421,343	S *	3/2000	Bennardo	D6/333
D496,166	S *	9/2004	Namikawa	D6/333
D596,411	S *	7/2009	May	D6/333

* cited by examiner

Primary Examiner—Caron Veynar

Assistant Examiner—Abraham Bahta

(74) *Attorney, Agent, or Firm*—Carter, Schnedler &
Warnock, P.A.

(57) **CLAIM**

The ornamental design for a booster seat, as shown and
described.

DESCRIPTION

FIG. 1 is a front elevational view of a booster seat embodying
the invention, in its in-use configuration;

FIG. 2 is a rear elevational view of the booster seat of FIG. 1;

FIG. 3 is a right side elevational view of the booster seat of
FIG. 1;

FIG. 4 is a left side elevational view of the booster seat of FIG.
1;

FIG. 5 is a top plan view of the booster seat of FIG. 1;

FIG. 6 is an underside view of the booster seat of FIG. 1;

FIG. 7 is a three-dimensional view of the booster seat of FIG.
1;

FIG. 8 is a front elevational view of the booster seat embody-
ing the invention, in its folded-up configuration;

FIG. 9 is a rear elevational view of the booster seat of FIG. 8,
the rear elevational view of the folded-up configuration of
FIG. 9 being essentially identical to the rear elevational view
of the in-use configuration of FIG. 2;

FIG. 10 is a right side elevational view of the booster seat of
FIG. 8;

FIG. 11 is a left side elevational view of the booster seat of
FIG. 8;

FIG. 12 is a top plan view of the booster seat of FIG. 8;

FIG. 13 is an underside view of the booster seat of FIG. 8; and,

FIG. 14 is a three-dimensional view of the booster seat of
FIG. 8.

1 Claim, 14 Drawing Sheets

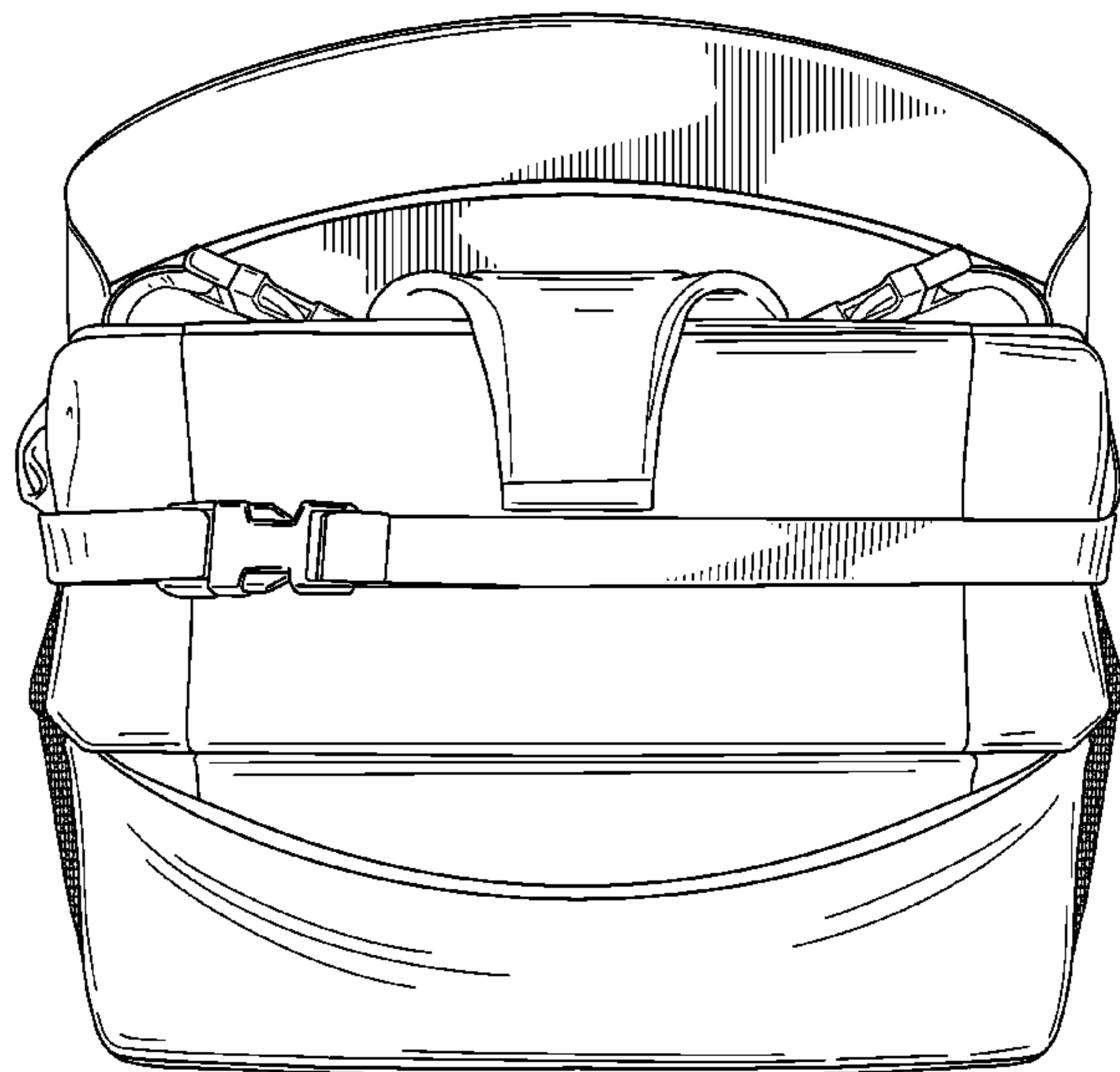
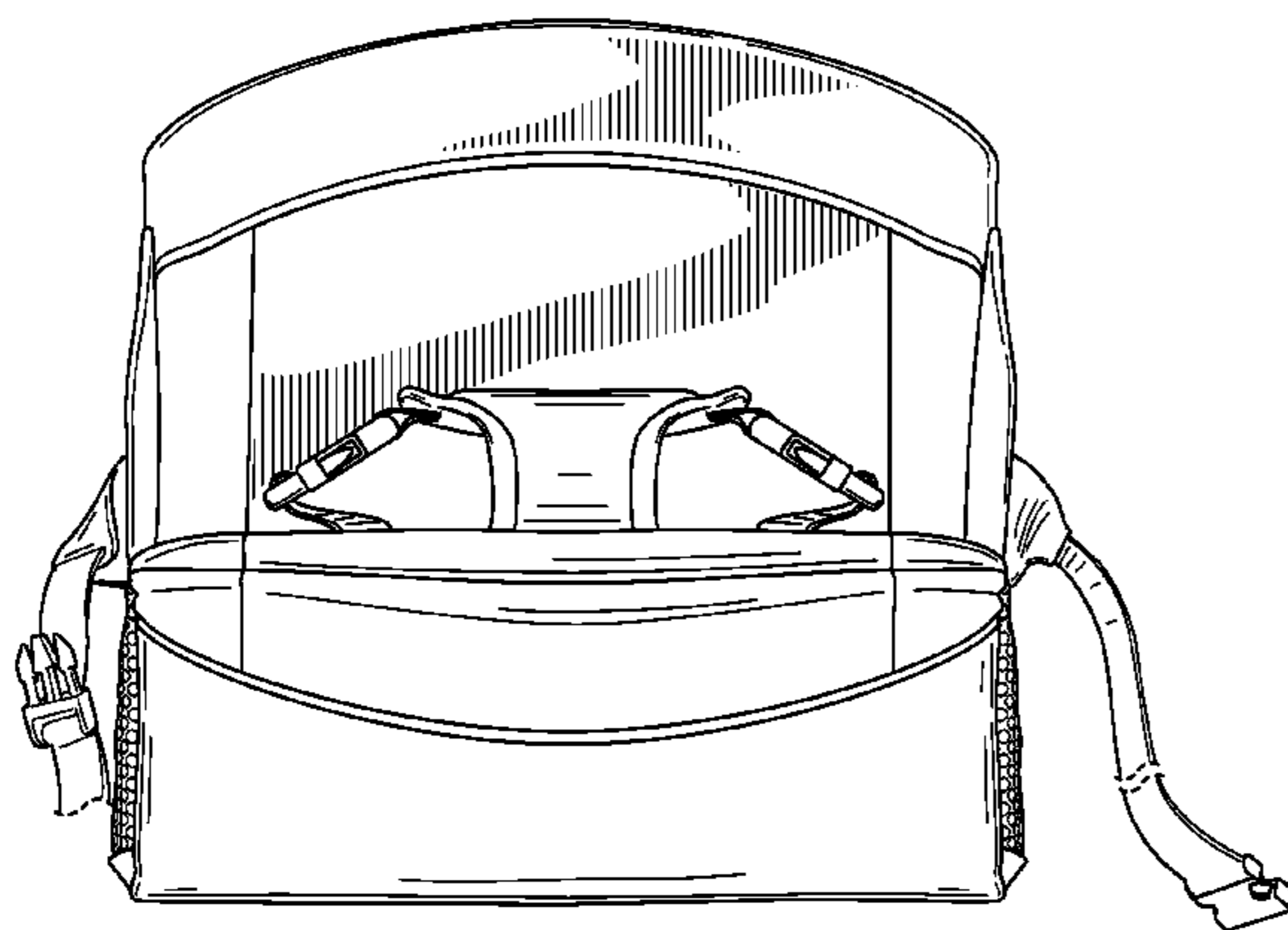

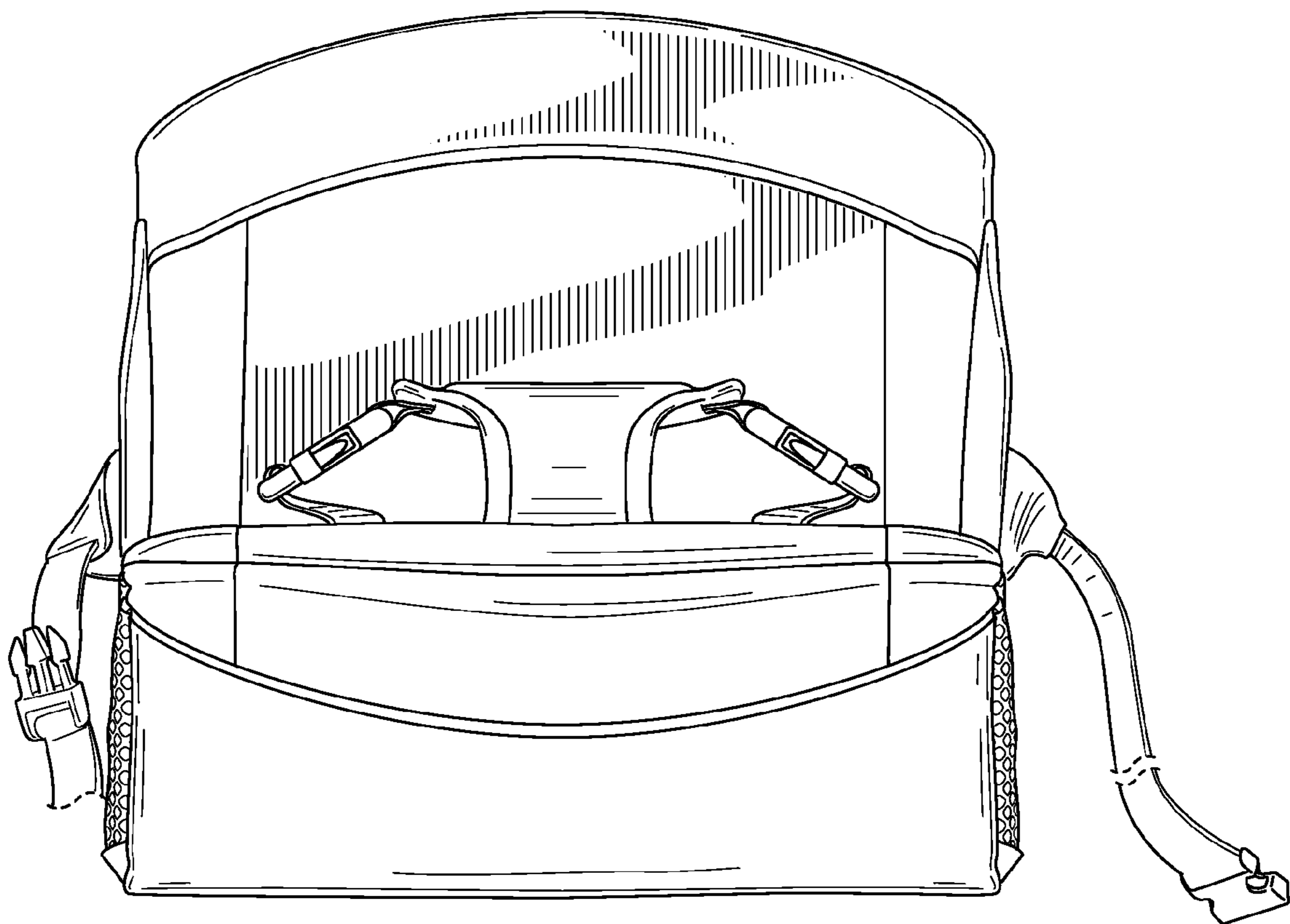

FIG. 1

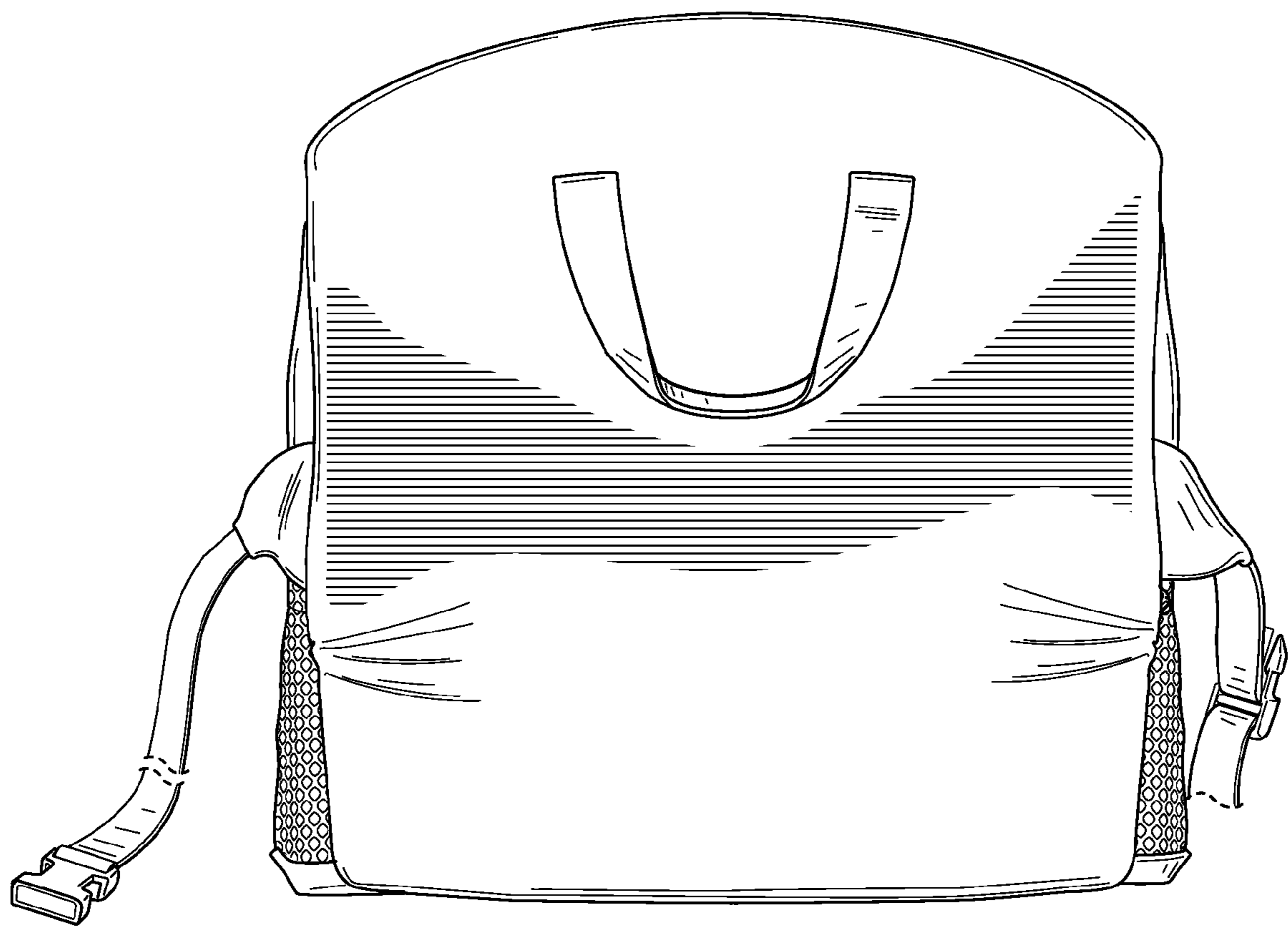

FIG. 2

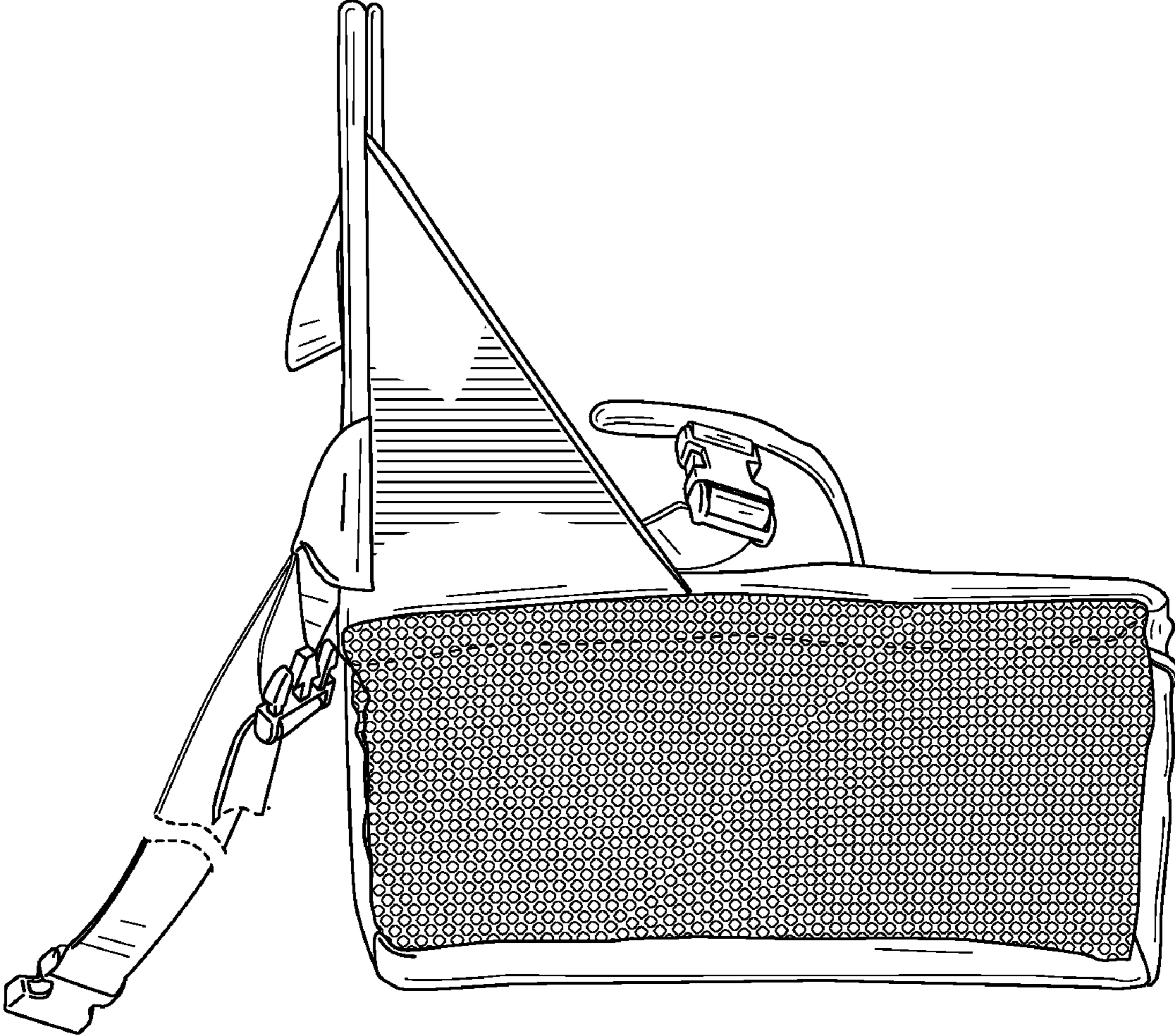

FIG. 3

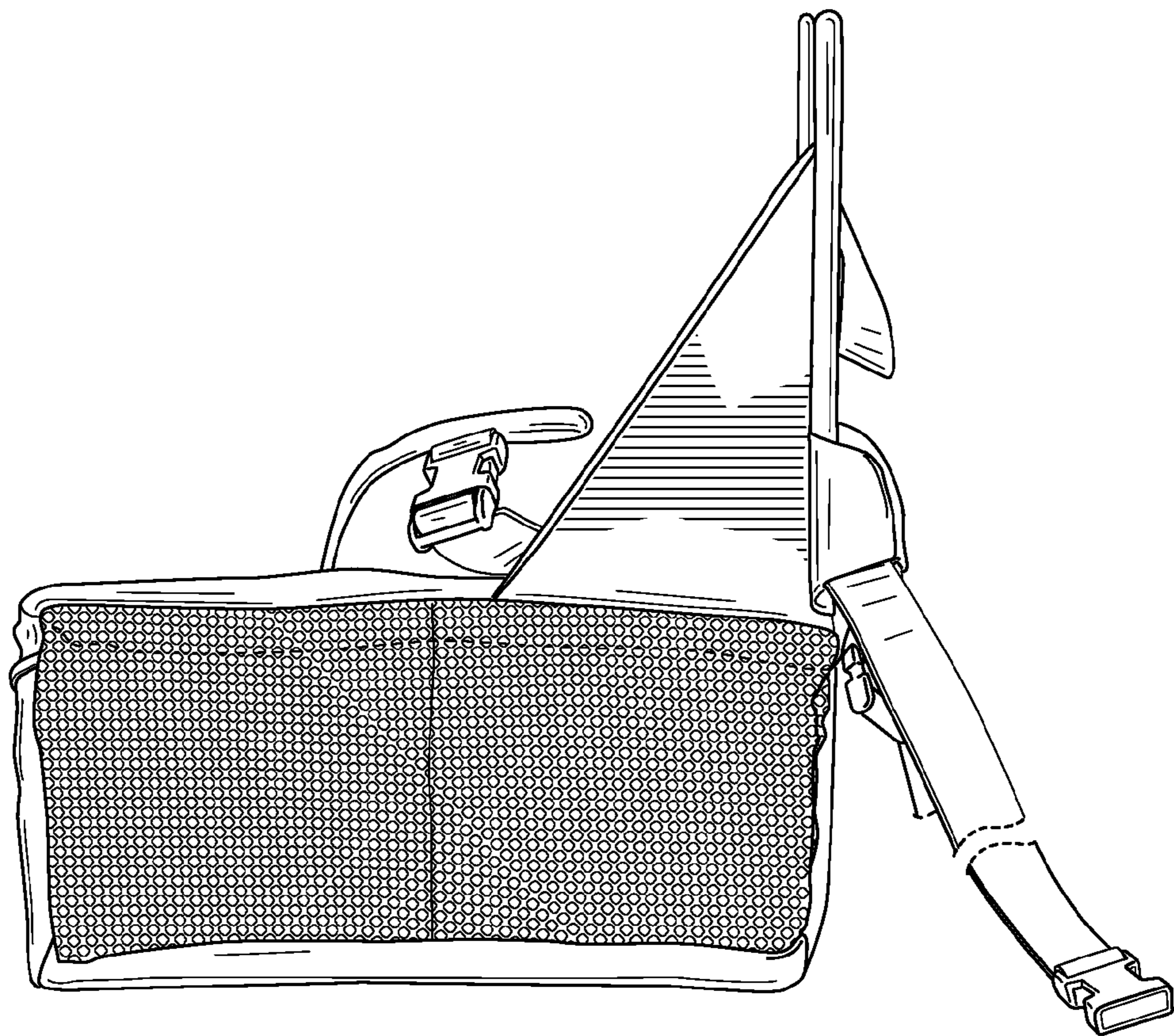

FIG. 4

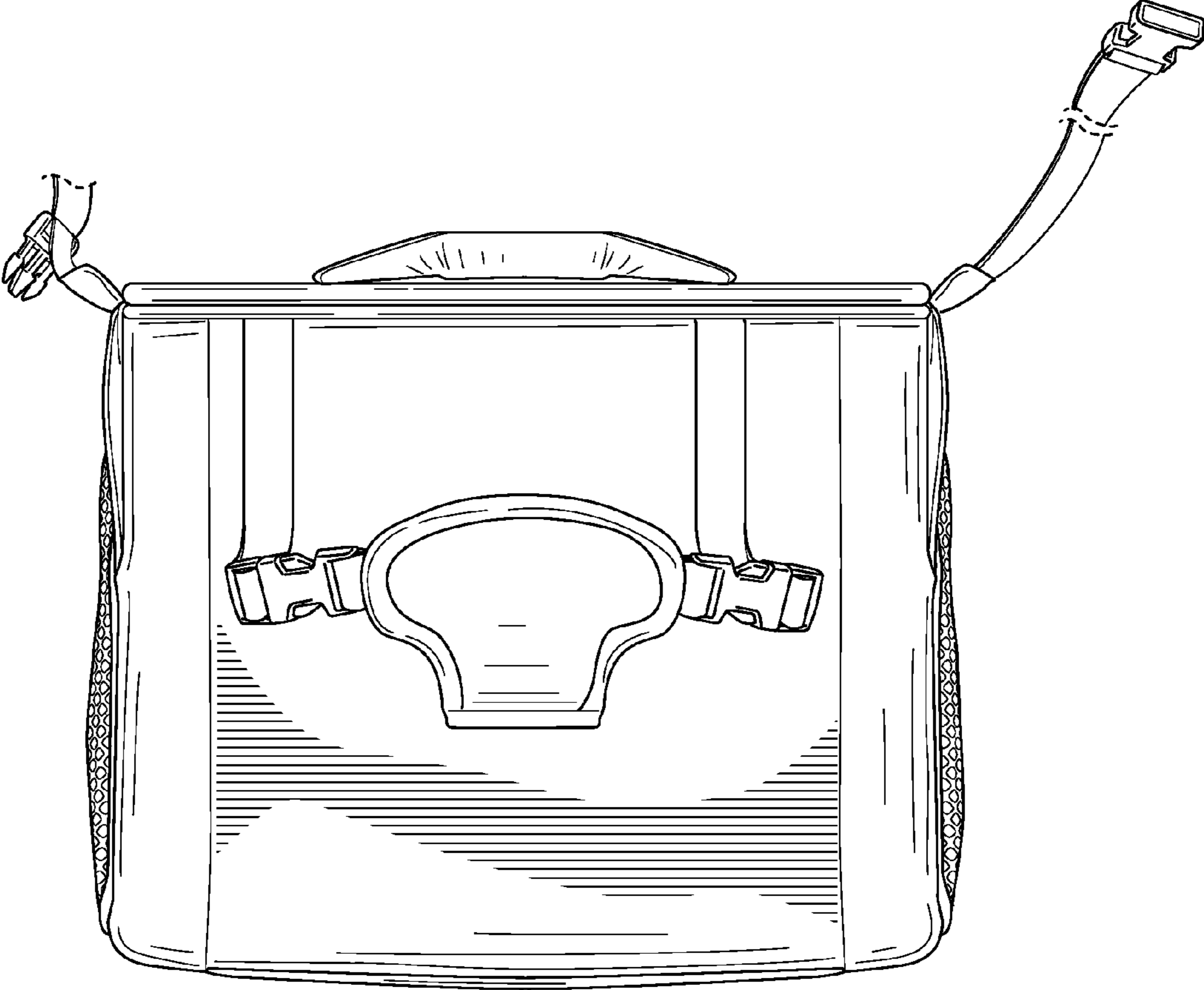

FIG. 5

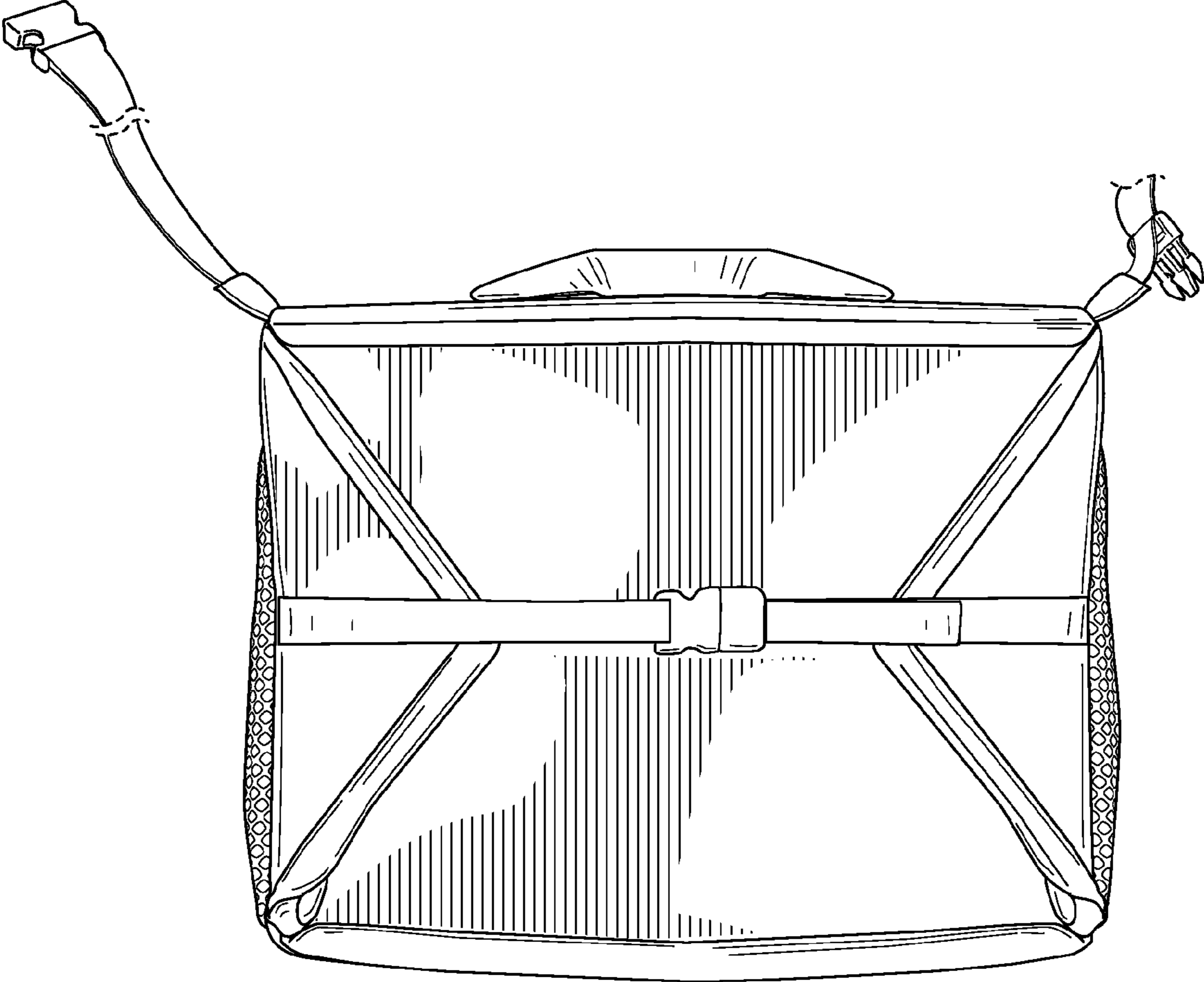

FIG. 6

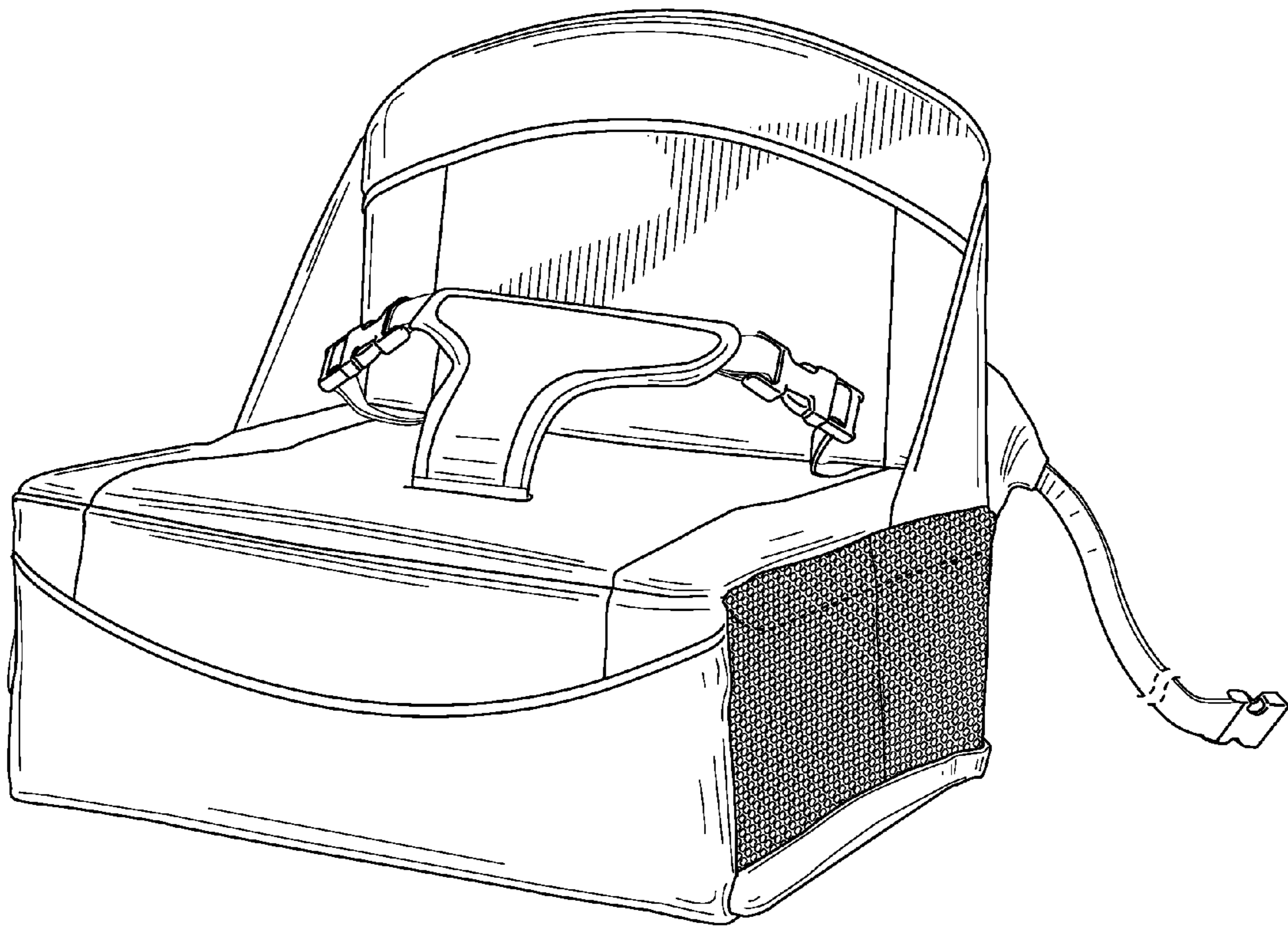

FIG. 7

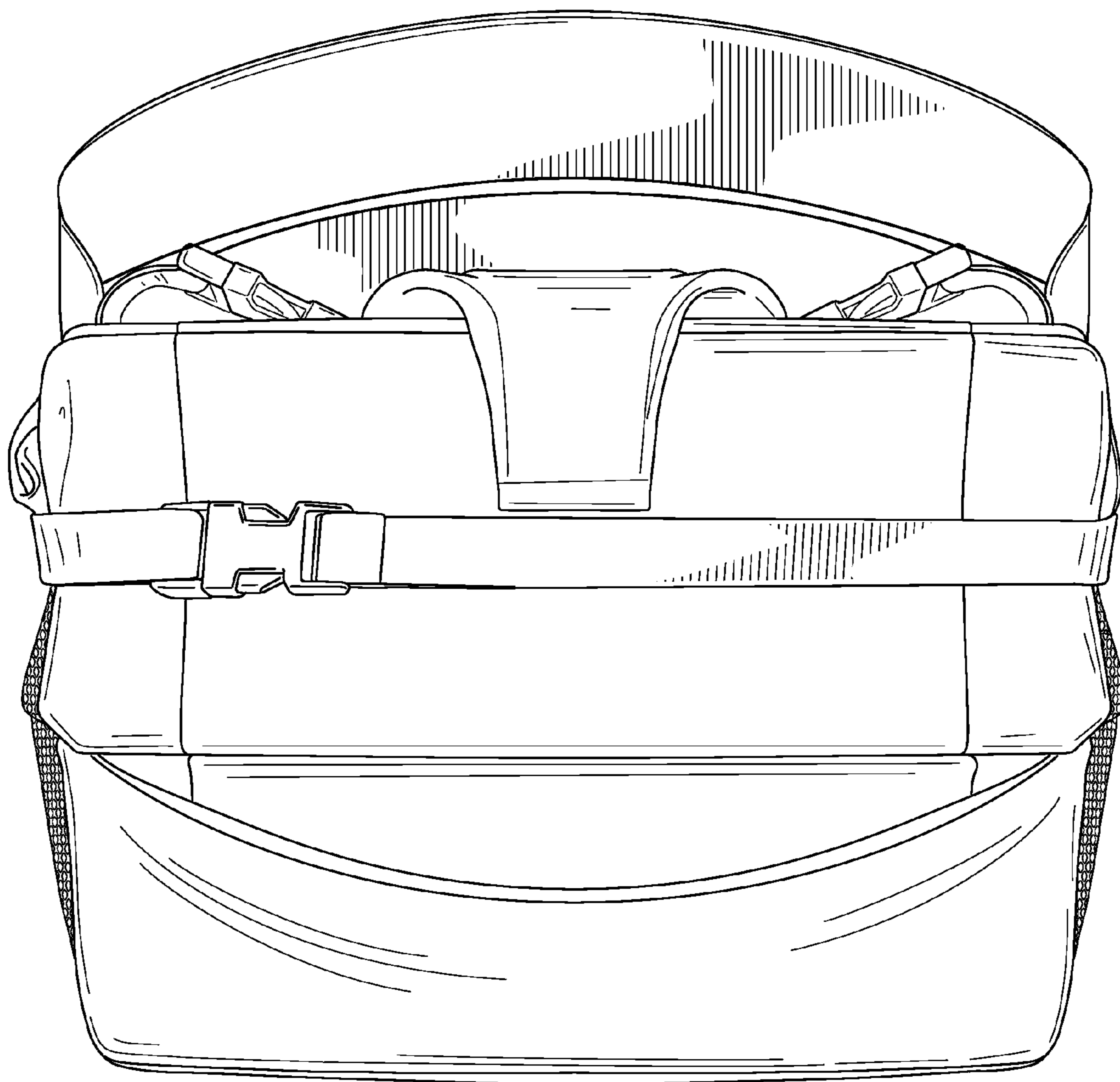

FIG. 8

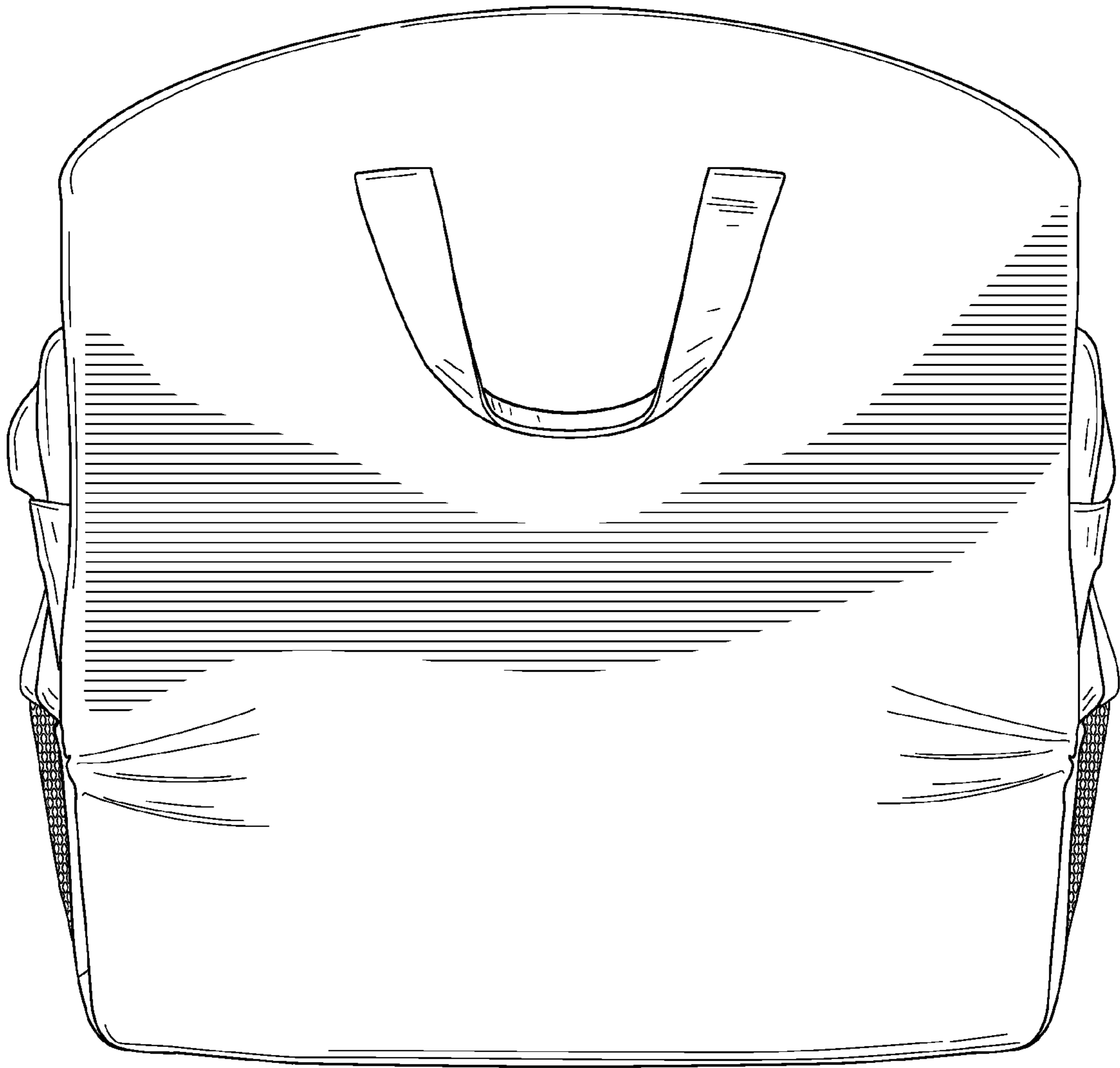

FIG. 9

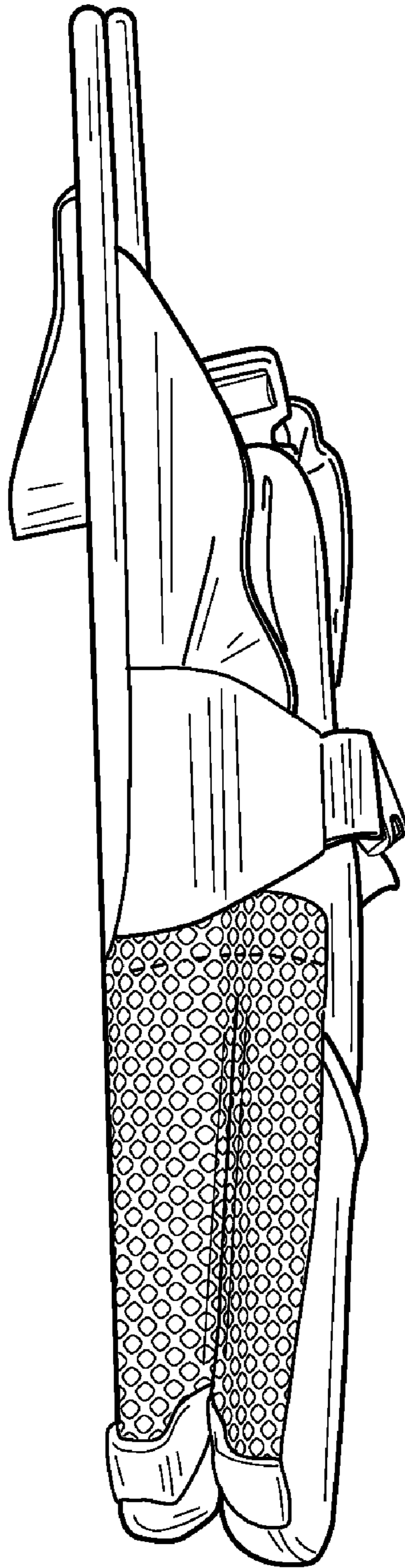

FIG. 10

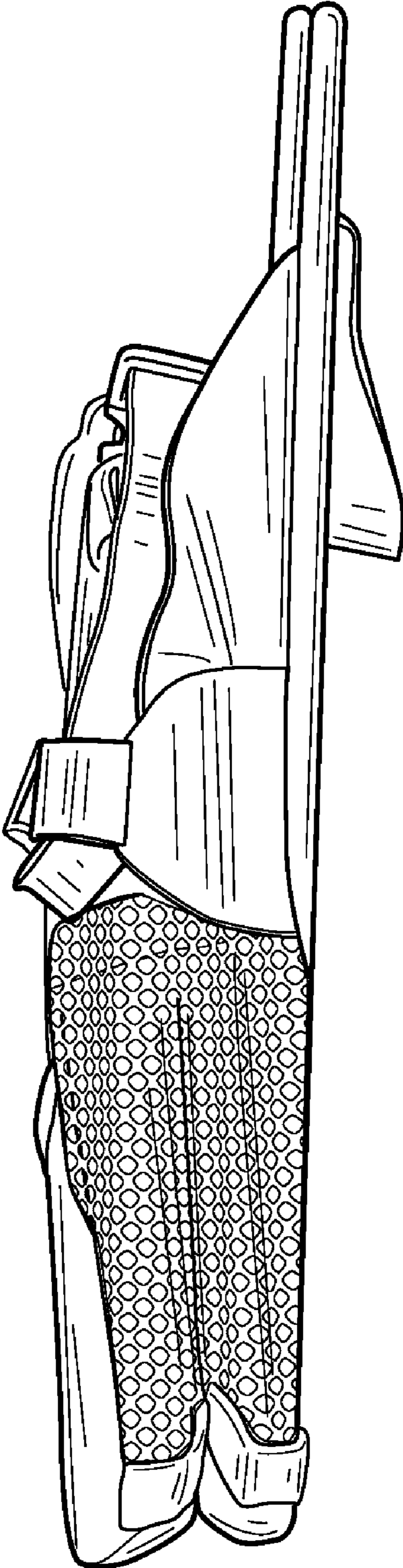

FIG. 11

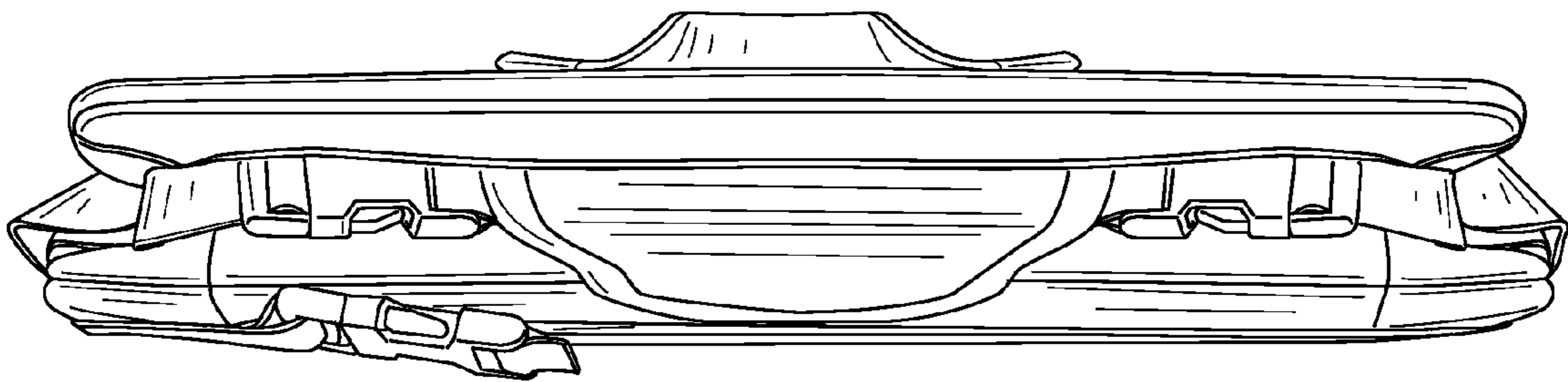

FIG. 12

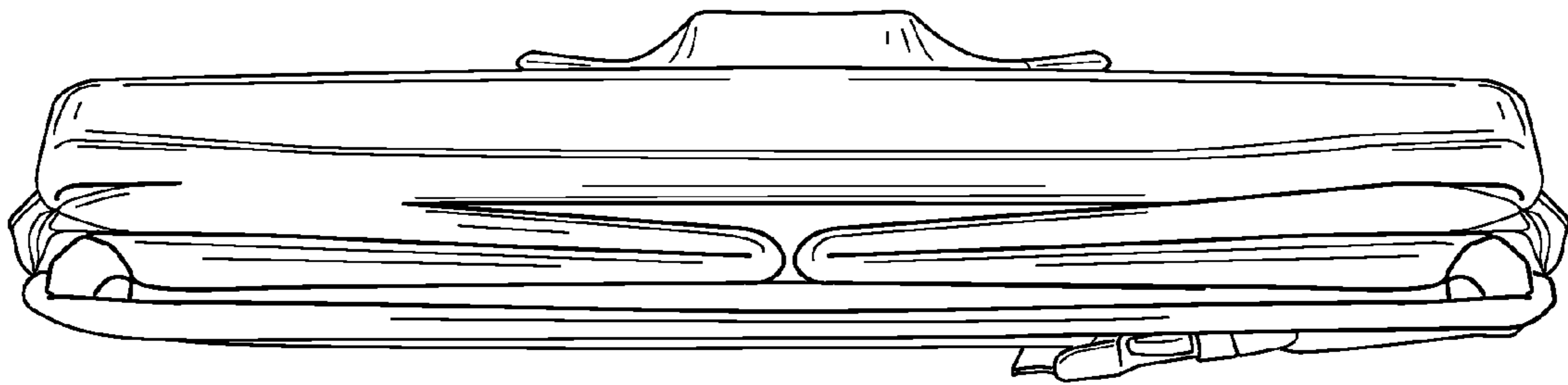

FIG. 13



FIG. 14