



US00D629447S

(12) **United States Design Patent**  
**Wegman et al.**

(10) **Patent No.:** **US D629,447 S**

(45) **Date of Patent:** **\*\* Dec. 21, 2010**

(54) **REPLENISHER TONER CONTAINER FOR A XEROGRAPHIC MACHINE**

(75) Inventors: **Paul M Wegman**, Pittsford, NY (US);  
**Kevin L Maltzahn**, Webster, NY (US);  
**Wayne D Drinkwater**, Fairport, NY (US);  
**Ricardo H Mendoza**, Webster, NY (US);  
**David B Playfair**, Penfield, NY (US);  
**Mark R Vannicola**, Rochester, NY (US)

(73) Assignee: **Xerox Corporation**, Norwalk, CT (US)

(\*\*) Term: **14 Years**

(21) Appl. No.: **29/351,776**

(22) Filed: **Dec. 11, 2009**

(51) **LOC (9) Cl.** ..... **16-03**

(52) **U.S. Cl.** ..... **D18/43**

(58) **Field of Classification Search** ..... D14/462,  
D14/471, 474, 475; D18/12, 36, 40, 43,  
D18/44, 56; 222/DIG. 1; 347/197, 214,  
347/222; 399/24-28, 107-115, 119, 121,  
399/122, 222-224

See application file for complete search history.

(56) **References Cited**

**U.S. PATENT DOCUMENTS**

D365,359 S \* 12/1995 Ichikawa et al. .... D18/43  
D376,614 S \* 12/1996 Ichikawa et al. .... D18/43  
D389,176 S \* 1/1998 Ichikawa et al. .... D18/43  
D406,162 S \* 2/1999 Tatsumi ..... D18/43

D430,197 S \* 8/2000 Wang et al. .... D18/43  
6,104,902 A \* 8/2000 Meyer et al. .... 222/DIG. 1  
D431,595 S \* 10/2000 Wang et al. .... D18/43  
D436,121 S \* 1/2001 Wang et al. .... D18/43  
D437,346 S \* 2/2001 Wang et al. .... D18/43  
D437,347 S \* 2/2001 Wang et al. .... D18/43  
D458,961 S \* 6/2002 Wang et al. .... D18/43  
D458,962 S \* 6/2002 Wang et al. .... D18/43  
D473,588 S \* 4/2003 Wang et al. .... D18/43

\* cited by examiner

*Primary Examiner*—Garth Rademaker

(74) *Attorney, Agent, or Firm*—Tallam I. Nguti

(57) **CLAIM**

The ornamental design for a replenisher toner container for a xerographic machine, as shown and described.

**DESCRIPTION**

FIG. 1 is a front perspective view of a replenisher toner container for a xerographic machine in accordance with the present invention;

FIG. 2 is a front view thereof;

FIG. 3 is a right side view thereof;

FIG. 4 is a rear view thereof;

FIG. 5 is a left side view thereof;

FIG. 6 is a top plan view thereof; and,

FIG. 7 is a bottom plan view thereof.

The broken lines depict environmental subject matter only and form no part of the claimed design.

**1 Claim, 6 Drawing Sheets**

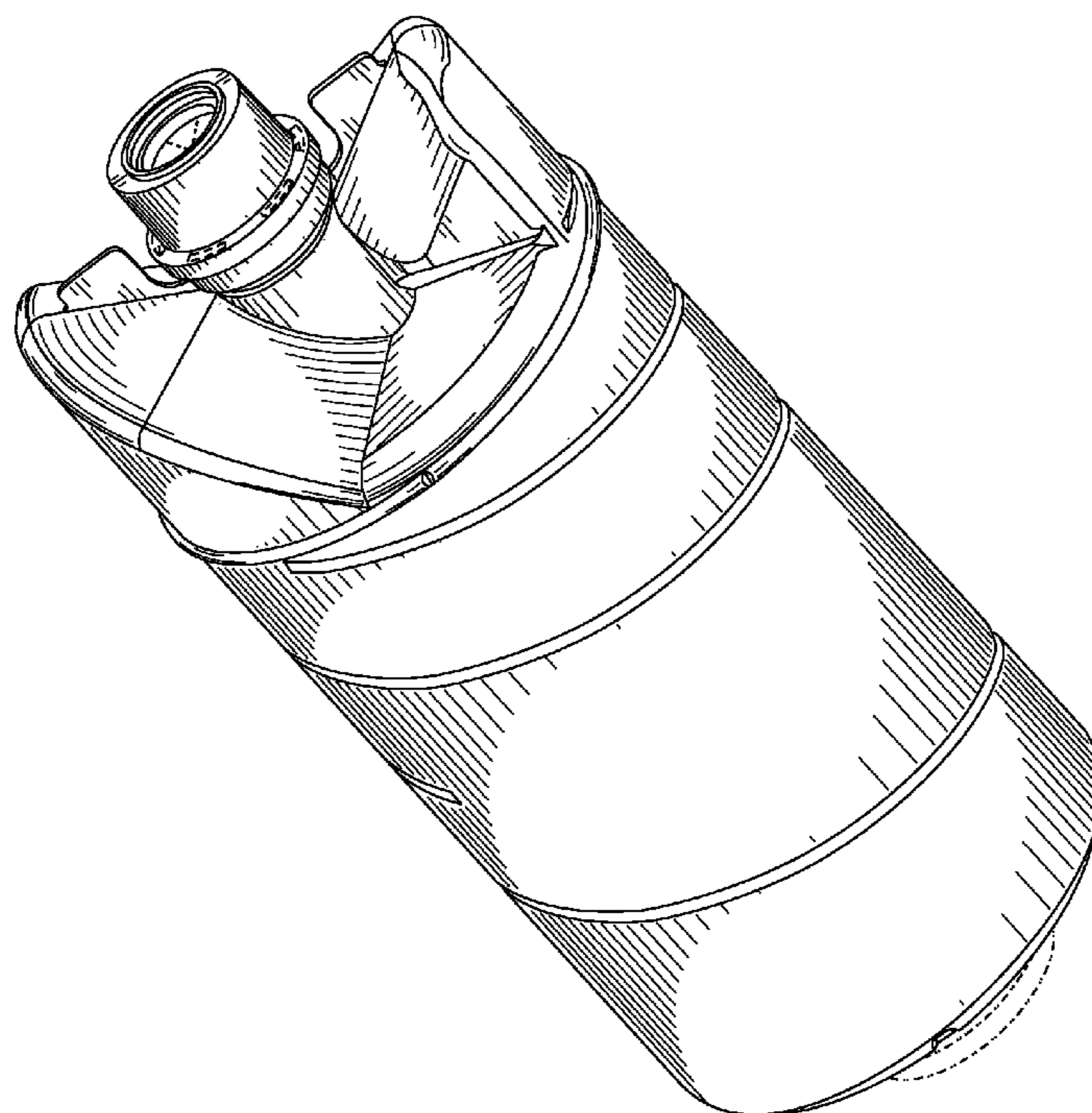

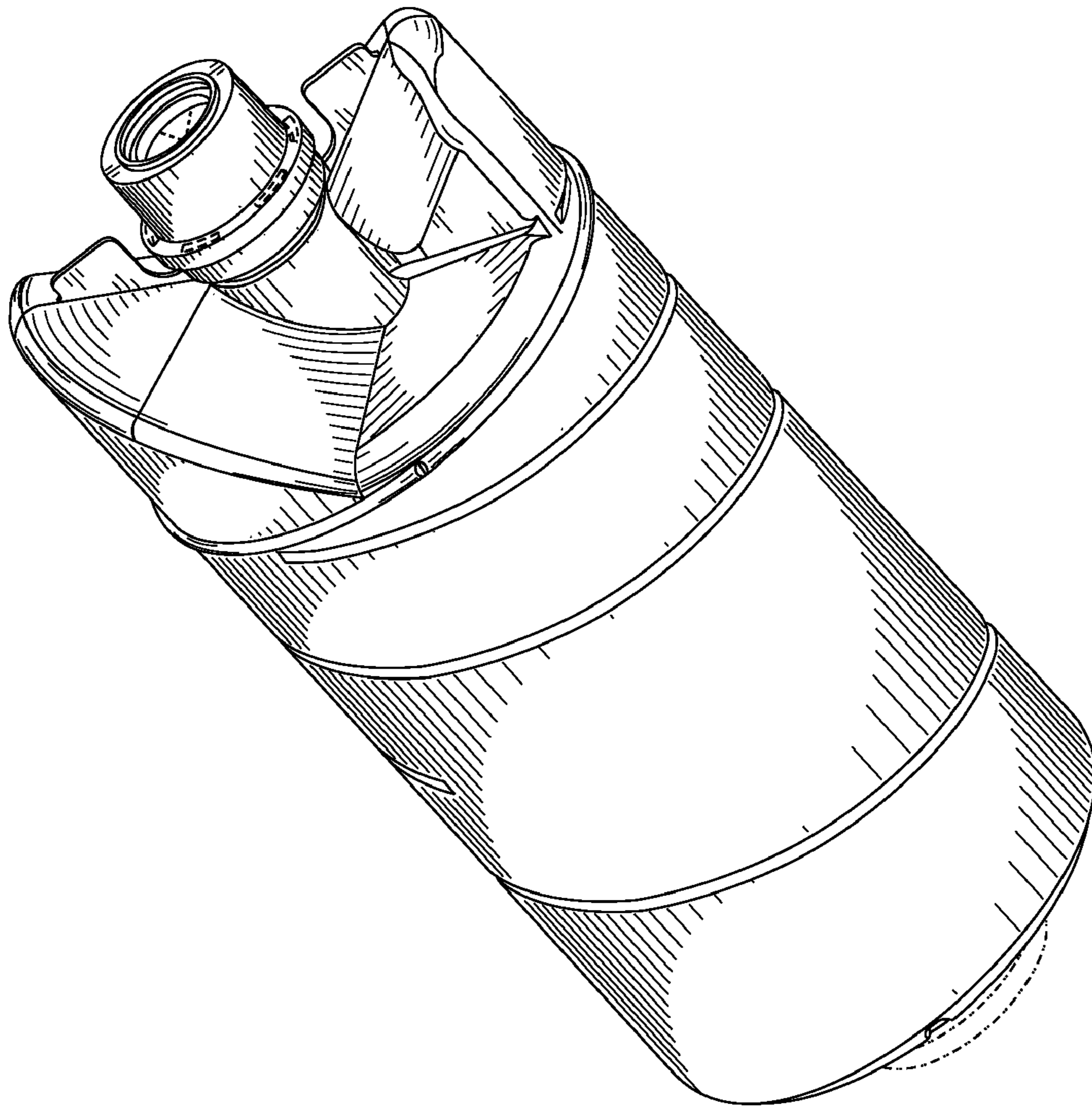

**FIG. 1**

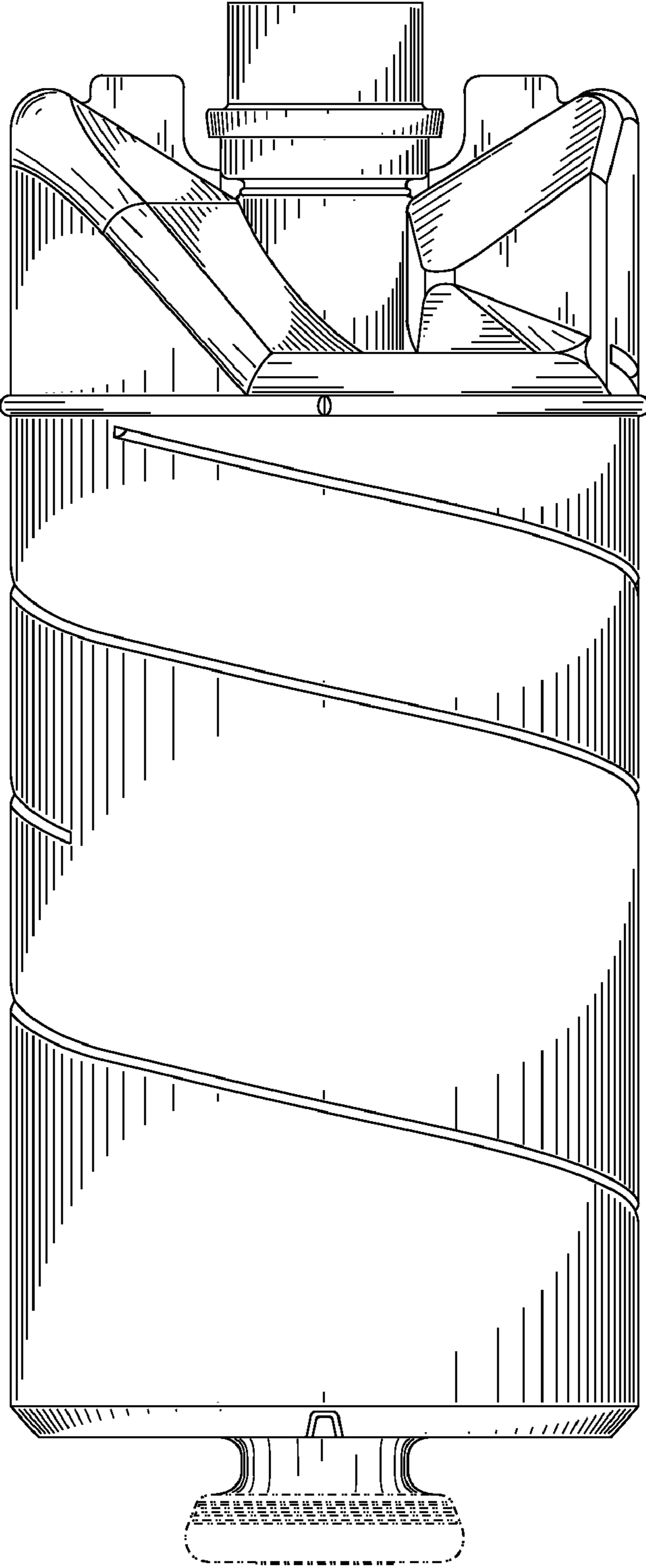
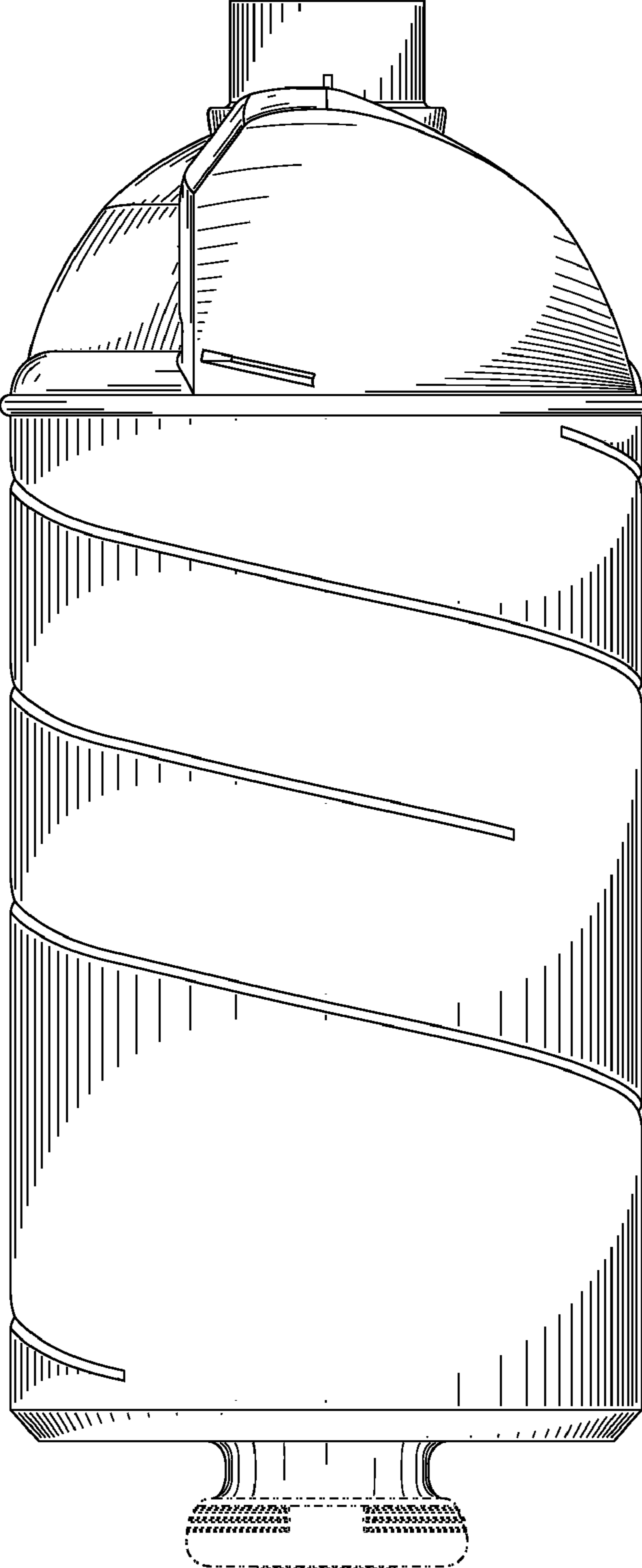
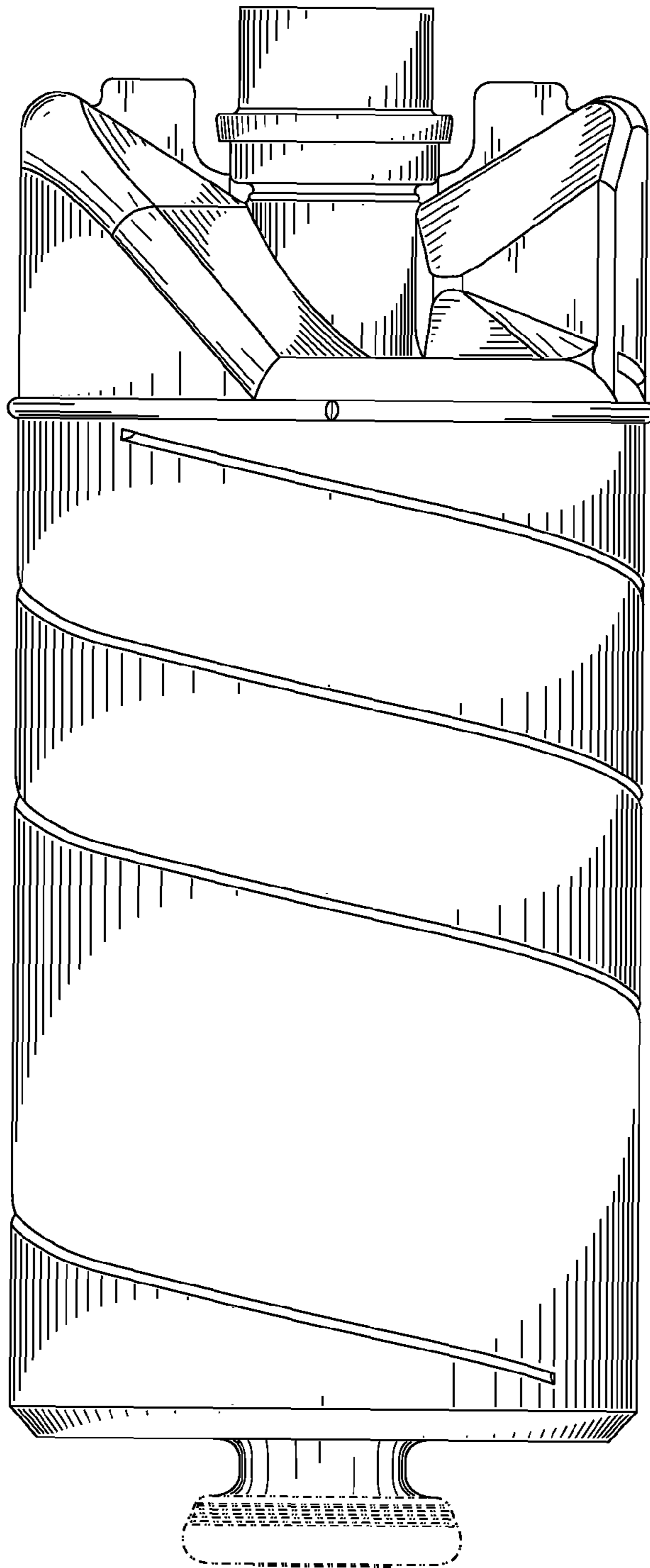

FIG. 2



**FIG. 3**





**FIG. 4**

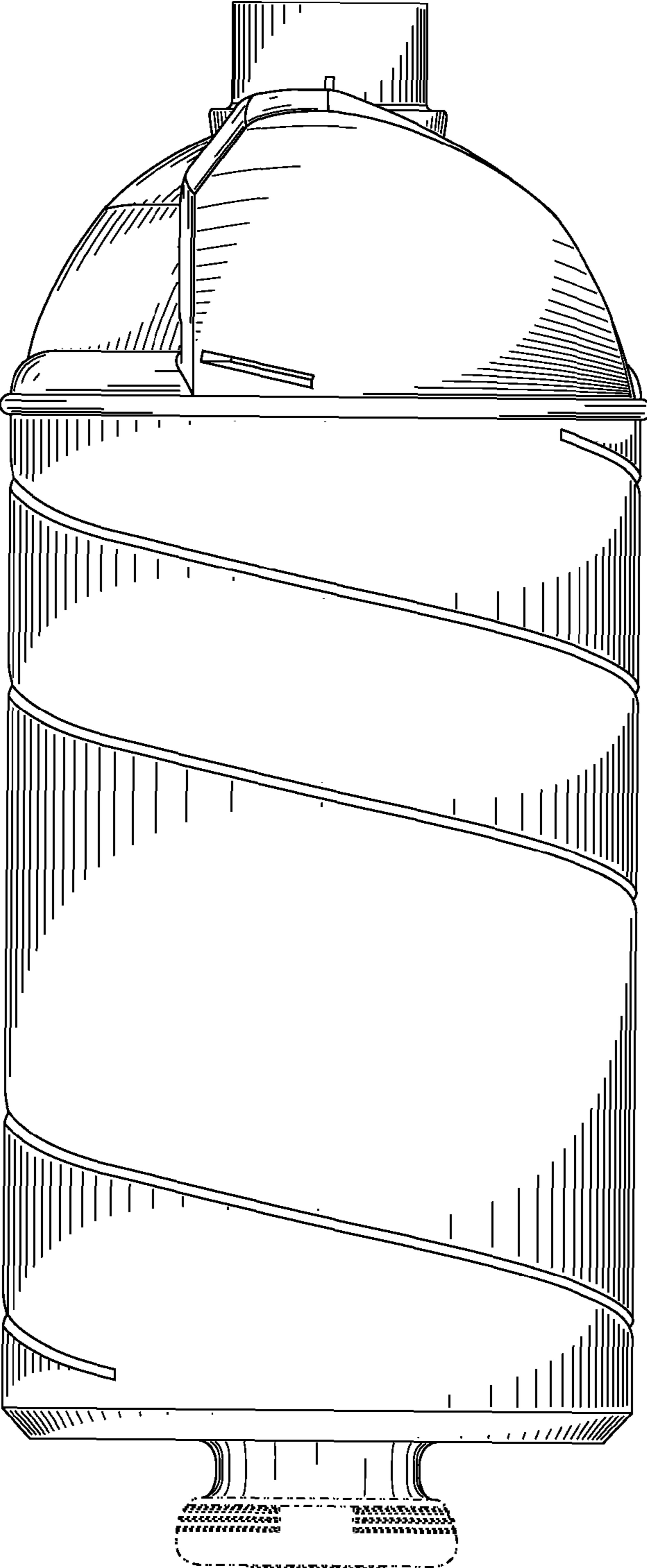
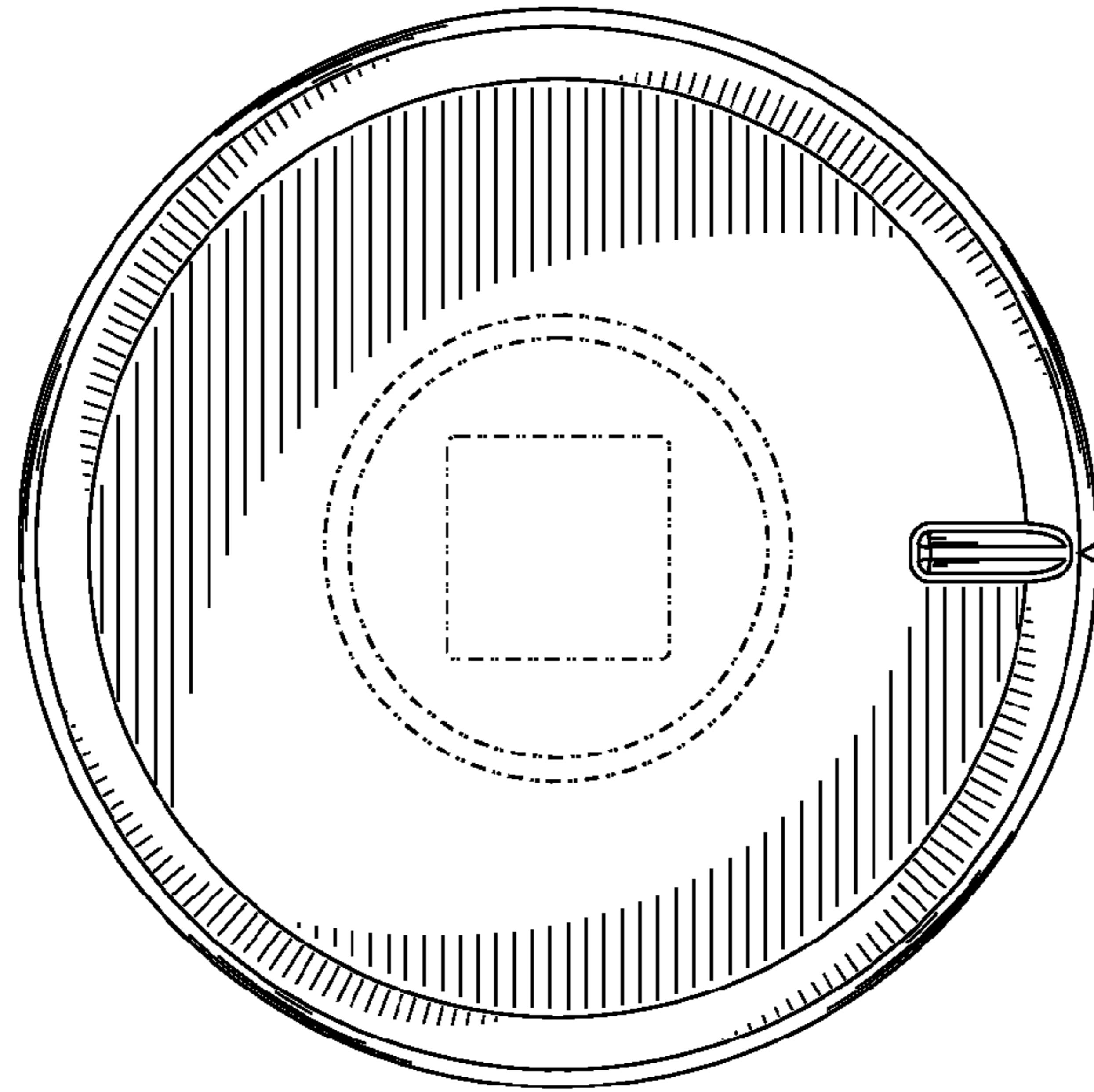
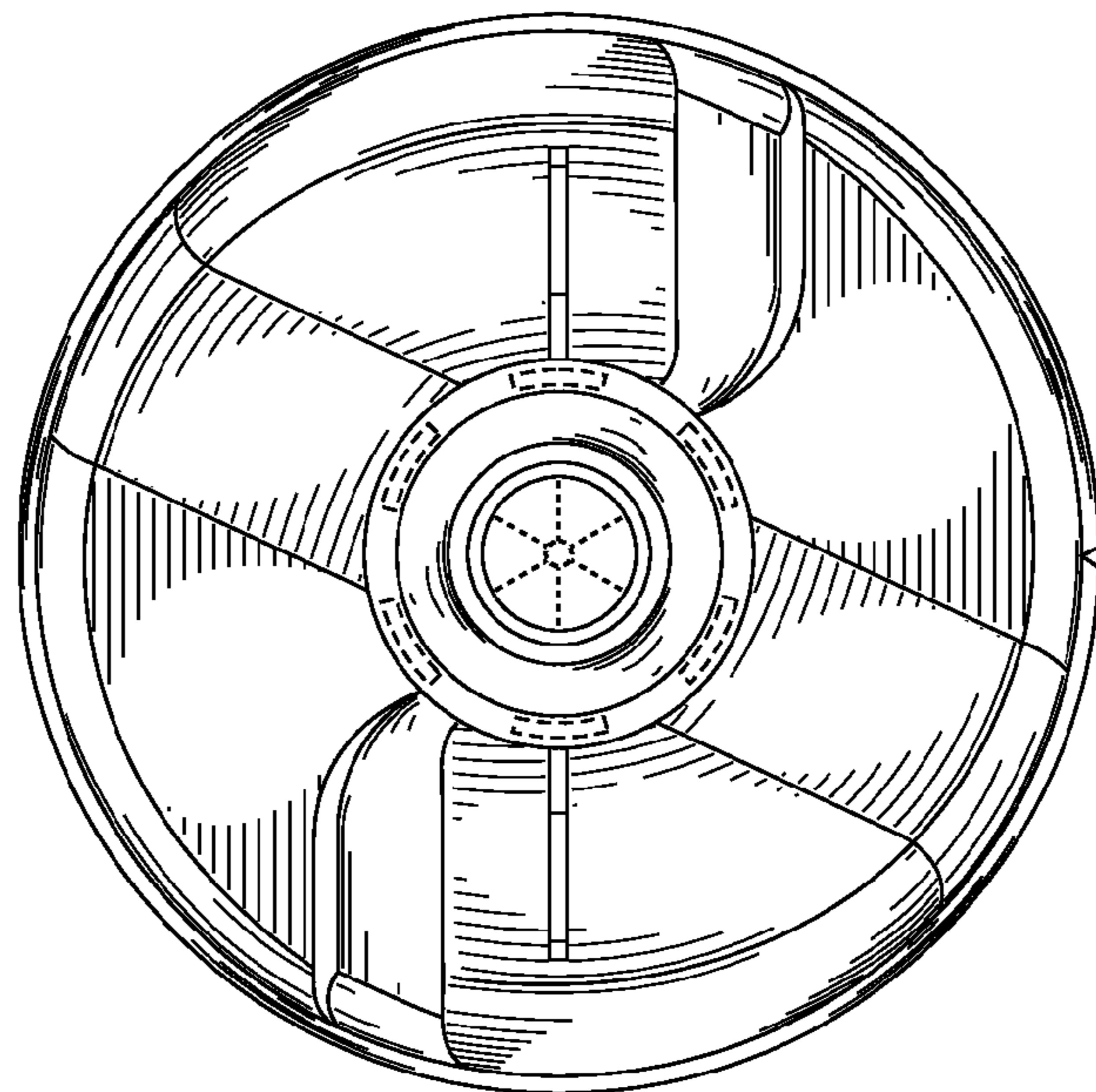

FIG. 5



**FIG. 6**



**FIG. 7**