



US00D629337S

(12) **United States Design Patent**
Stahel, Jr. et al.

(10) **Patent No.:** **US D629,337 S**
(45) **Date of Patent:** **** Dec. 21, 2010**

(54) **MOTORCYCLE IGNITION AND CONTROL SWITCH TRIM**

(75) Inventors: **Alwin J. Stahel, Jr.**, St. Paul, MN (US);
Brian K. Stahel, St. Paul, MN (US)

(73) Assignee: **Kuryakyn Holdings, Inc.**, Somerset, WI (US)

(**) Term: **14 Years**

(21) Appl. No.: **29/348,681**

(22) Filed: **Jan. 28, 2010**

(51) **LOC (9) Cl.** **12-11**

(52) **U.S. Cl.** **D12/126**

(58) **Field of Classification Search** D12/126,
D12/114, 110, 177, 192, 415; D13/156,
D13/158, 126, 133, 162; D10/1, 2, 4, 5,
D10/14, 21, 27, 28, 52, 53; 200/43.03, 293,
200/294, 302.1, 334, 345; 123/647, 195 A,
123/198 DC, 195 C, 198 D, 195 E, 195 R;
180/219, 220

See application file for complete search history.

(56) **References Cited**

U.S. PATENT DOCUMENTS

D46,129 S * 7/1914 Kienzle D10/1
D160,077 S * 9/1950 Eaves D10/4
D192,480 S * 3/1962 Lowe D10/53
D260,636 S * 9/1981 Duden D13/126
D290,245 S * 6/1987 Opitz D12/126
D476,276 S * 6/2003 Day D12/192

D484,081 S * 12/2003 Day D12/192
D492,213 S * 6/2004 Day et al. D10/103
6,948,472 B2 * 9/2005 Suzuki et al. 123/198 D
D620,405 S * 7/2010 Yeung D12/177

OTHER PUBLICATIONS

J & P Cycles® Keeping the World on 2 Wheels® 2007 Metric Cruiser Catalog, Instruments and Handlebar Accessories on p. 242.*

* cited by examiner

Primary Examiner—Philip S Hyder

Assistant Examiner—Linda G. Brooks

(74) *Attorney, Agent, or Firm*—Dicke, Billig & Czaja, PLLC

(57) **CLAIM**

The ornamental design for a motorcycle ignition and control switch trim, as shown and described.

DESCRIPTION

FIG. 1 is a top perspective view of the motorcycle ignition and control switch trim of the present invention.

FIG. 2 is a front side elevation view thereof.

FIG. 3 is a rear side elevation view thereof.

FIG. 4 is a top view thereof.

FIG. 5 is a bottom view thereof; and,

FIG. 6 is a left side view thereof, the right side being a mirror image thereof.

Those portions of the motorcycle ignition and control switch trim shown in broken lines, namely the rear side, bottom side and front surface portions, form no part of the claimed design.

1 Claim, 5 Drawing Sheets

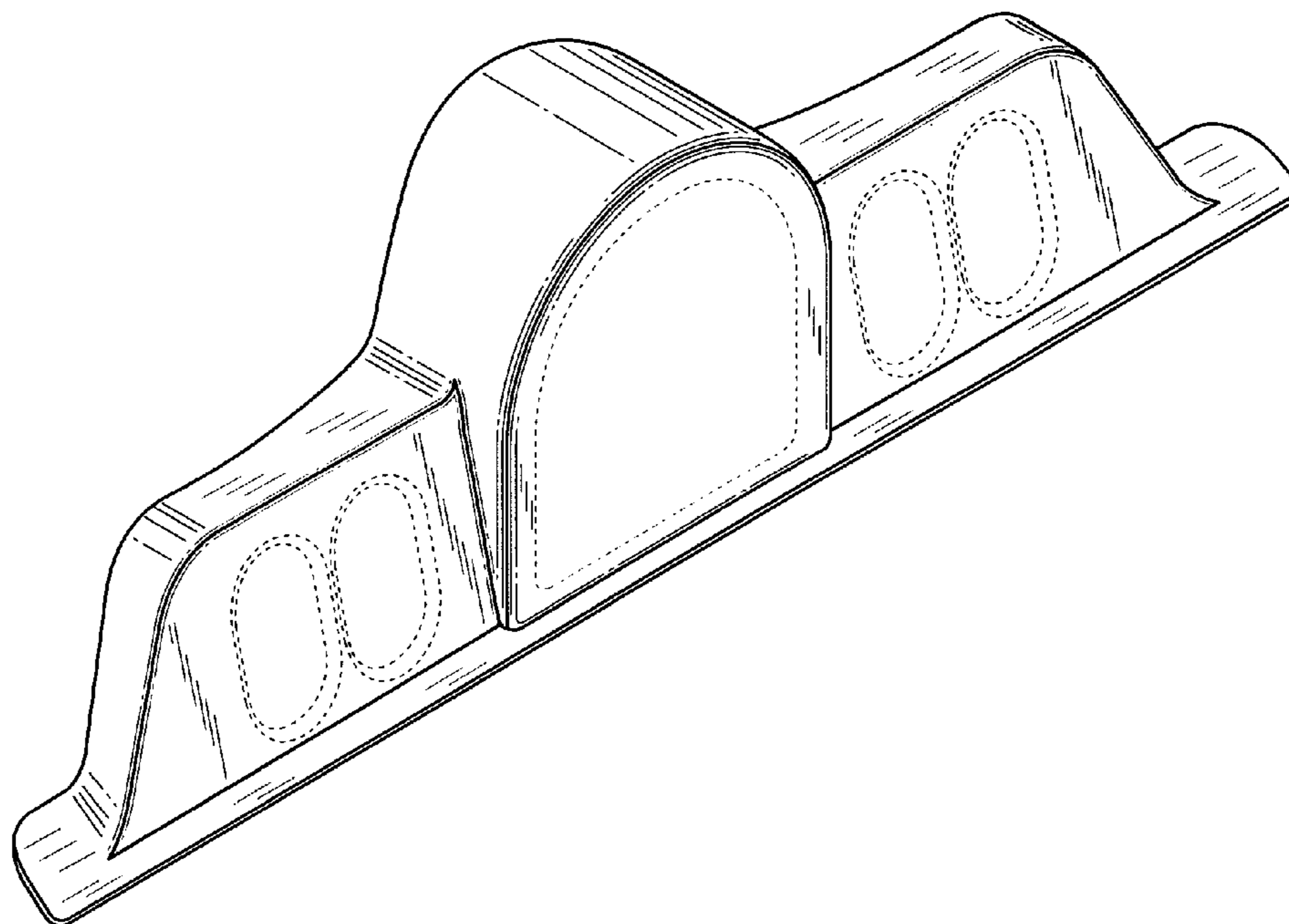

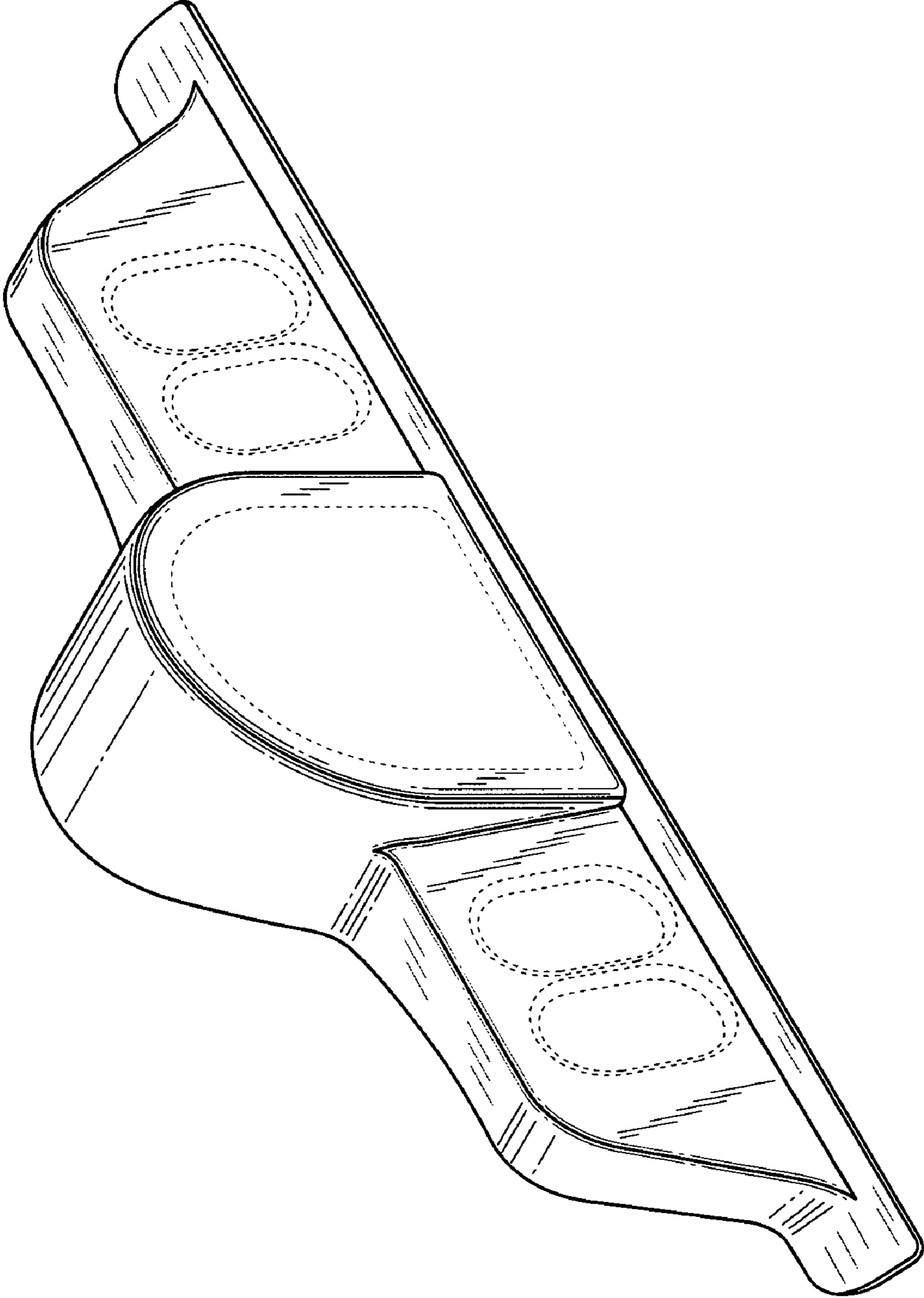

Fig. 1

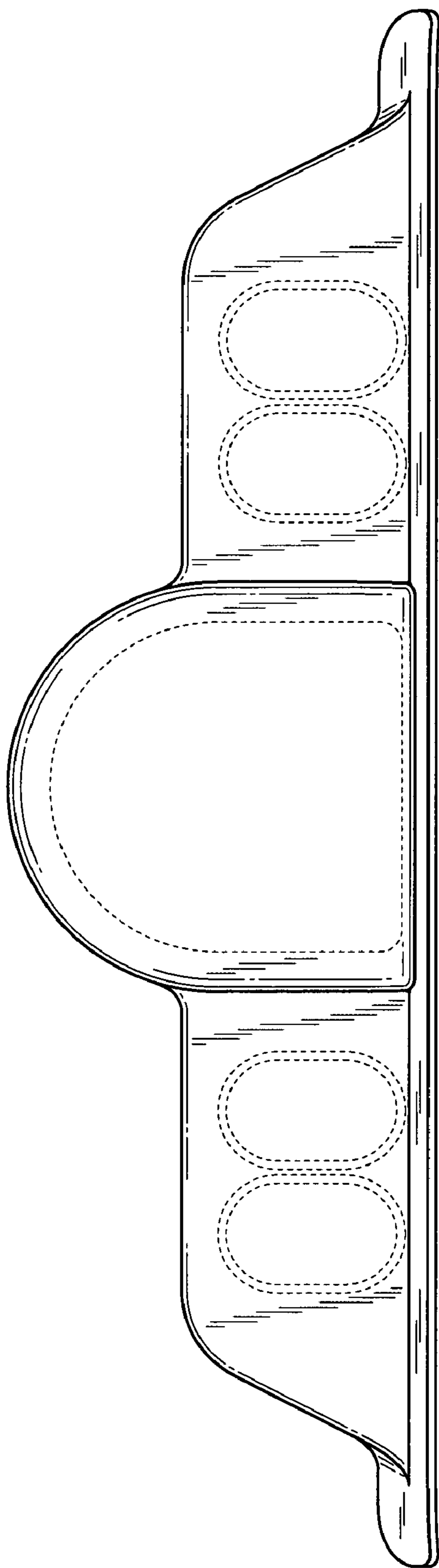

Fig. 2

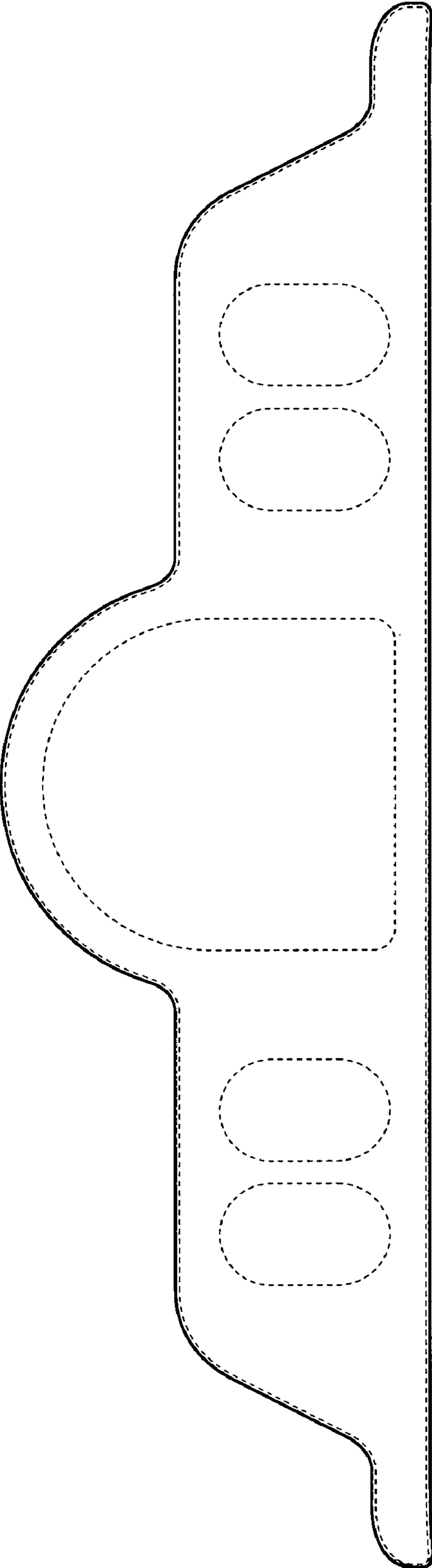

Fig. 3

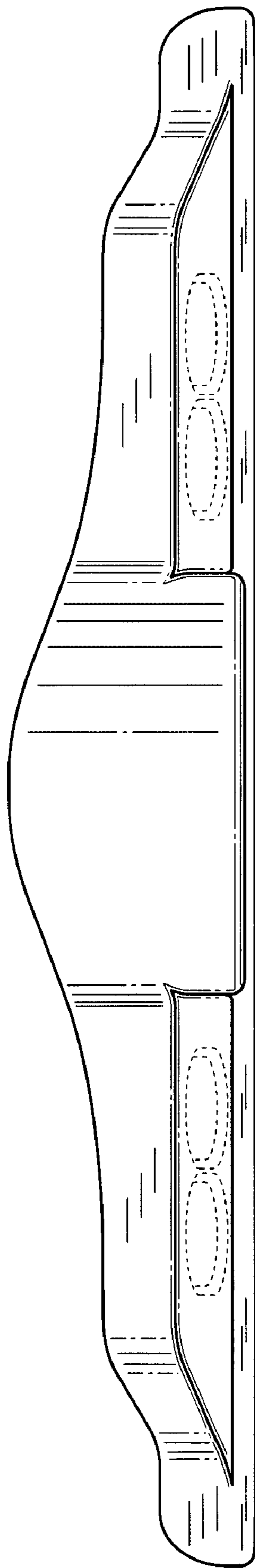

Fig. 4

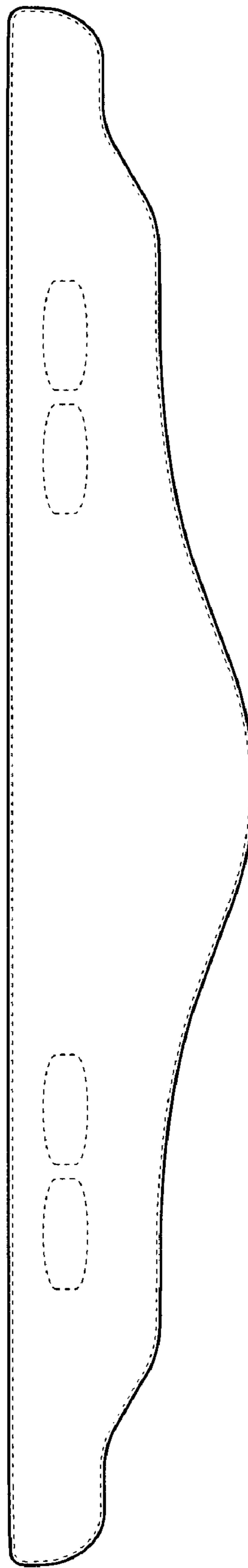

Fig. 5

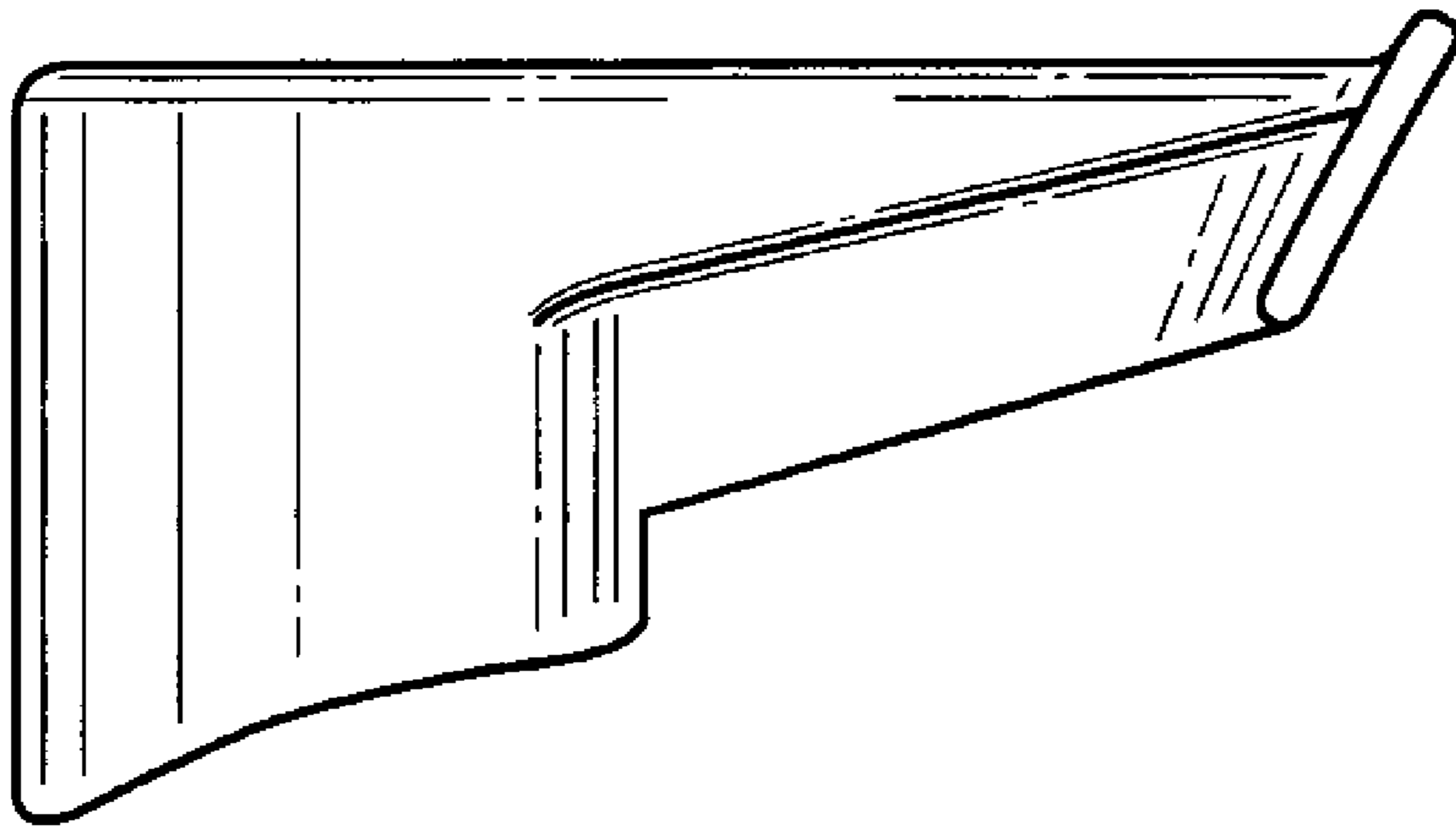

Fig. 6