



US00D629261S

(12) **United States Design Patent**  
**Hollinger**

(10) **Patent No.:** **US D629,261 S**

(45) **Date of Patent:** **\*\* Dec. 21, 2010**

(54) **CUTTING EDGE**

(75) Inventor: **Fred Hollinger**, Monroe, NJ (US)

(73) Assignee: **E. Mishan & Sons, Inc.**, New York, NY (US)

(\*\*) Term: **14 Years**

(21) Appl. No.: **29/366,563**

(22) Filed: **Jul. 27, 2010**

**Related U.S. Application Data**

(62) Division of application No. 29/363,357, filed on Jun. 8, 2010.

(51) **LOC (9) Cl.** ..... **07-03**

(52) **U.S. Cl.** ..... **D7/650; D7/649**

(58) **Field of Classification Search** ..... D7/368,  
D7/393-395, 401.2, 642-653, 669, 675-676,  
D7/688-696; D8/20, 97-99, 102, 107, 300,  
D8/303, 321; D22/117-118; D24/147; 16/110.1,  
16/407, 430, DIG. 18; 30/136, 142-150,  
30/329, 340-346, 355

See application file for complete search history.

(56) **References Cited**

**U.S. PATENT DOCUMENTS**

495,110 A \* 4/1893 Hayes et al. .... 30/355  
D24,386 S \* 6/1895 Christy ..... D7/650  
D158,459 S \* 5/1950 Gustafson ..... D7/650  
D248,166 S \* 6/1978 Kanai ..... D24/147  
D324,326 S \* 3/1992 Lu ..... D7/650

D403,559 S \* 1/1999 Terenzio ..... D7/650  
6,044,566 A \* 4/2000 Ries et al. .... 30/345  
D455,057 S \* 4/2002 Medhurst ..... D8/20  
D500,233 S \* 12/2004 Overthun ..... D7/650  
D545,637 S \* 7/2007 Curtin ..... D7/650  
D554,949 S \* 11/2007 Hood ..... D7/650  
D581,733 S \* 12/2008 Epstein ..... D7/401.2  
D620,322 S \* 7/2010 Hollinger ..... D7/649

\* cited by examiner

*Primary Examiner*—Ricky Pham

(74) *Attorney, Agent, or Firm*—Notaro, Michalos & Zaccaria P.C.

(57) **CLAIM**

The ornamental design for a cutting edge, as shown and described.

**DESCRIPTION**

FIG. 1 is front right bottom perspective view of a cutting edge of a knife blade with the rest of the blade and the handle shown in phantom line forming no part of the design;

FIG. 2 is a rear top left perspective view thereof;

FIG. 3 is a right side elevational view thereof;

FIG. 4 is a left side elevational view thereof;

FIG. 5 is a front elevational view thereof;

FIG. 6 is a rear elevational view thereof;

FIG. 7 is a top plan view thereof; and,

FIG. 8 is a bottom plan view thereof.

**1 Claim, 6 Drawing Sheets**

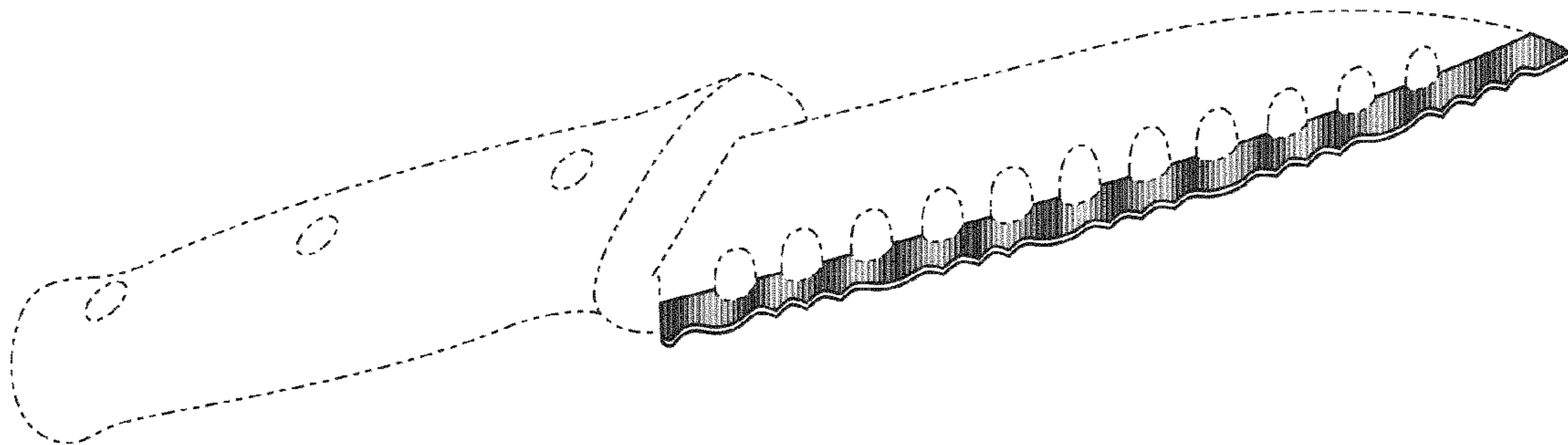

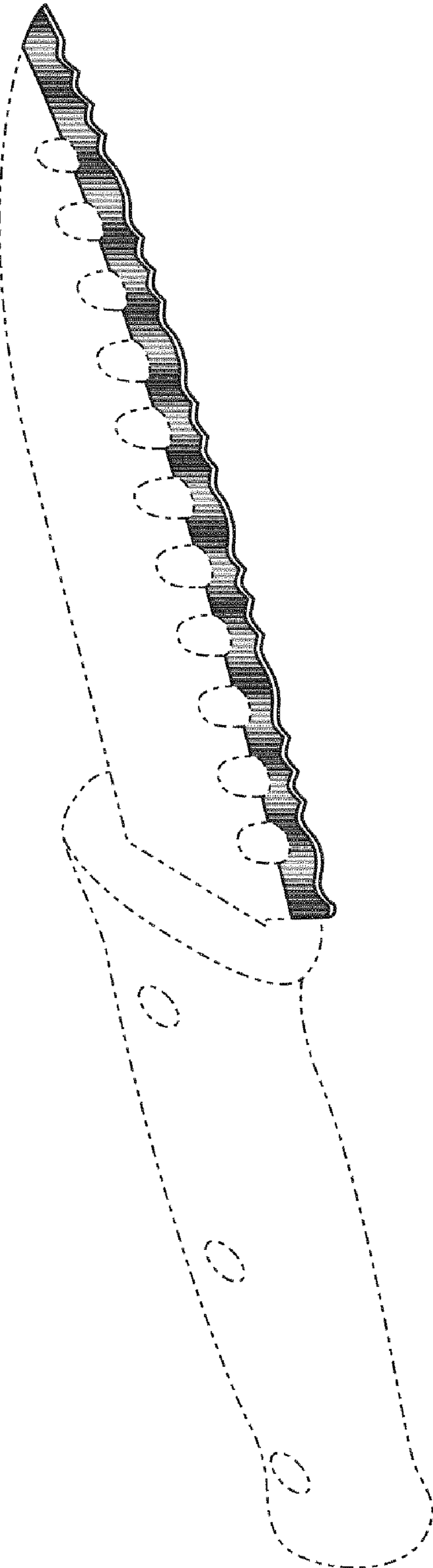

FIG. 1

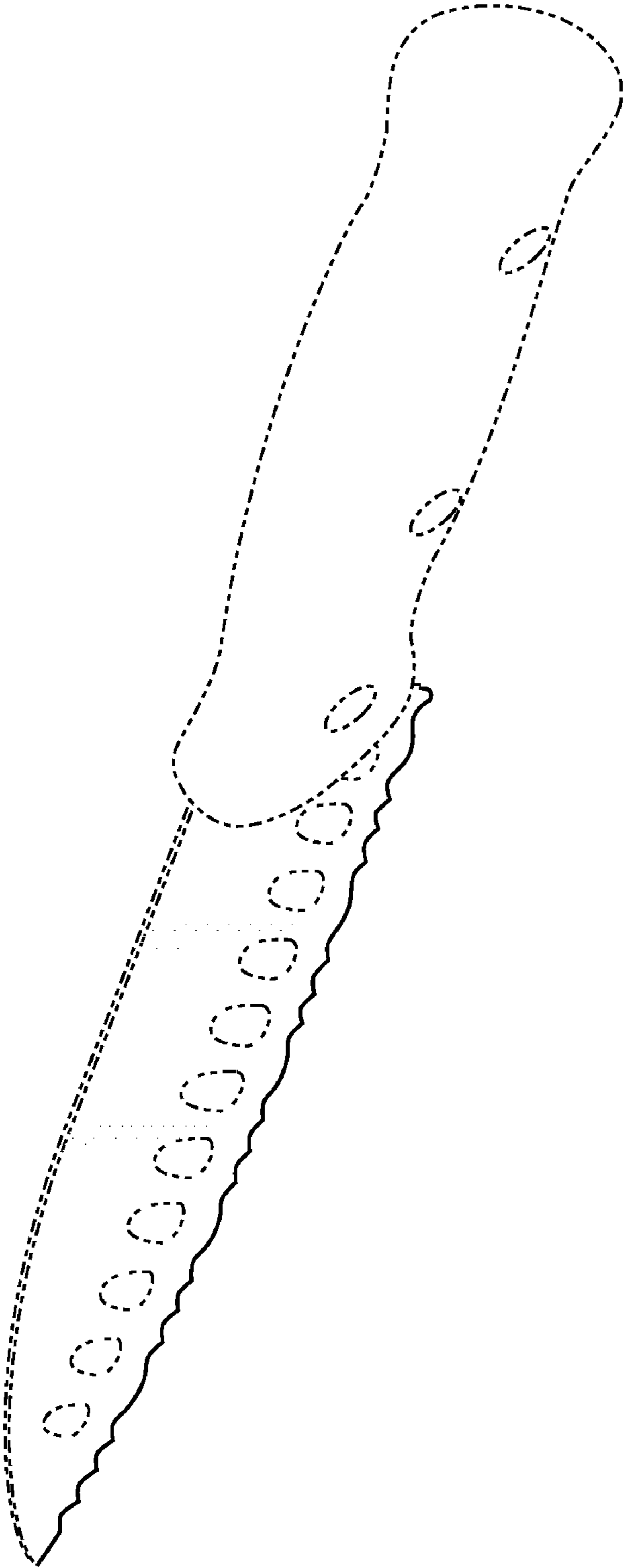

FIG. 2

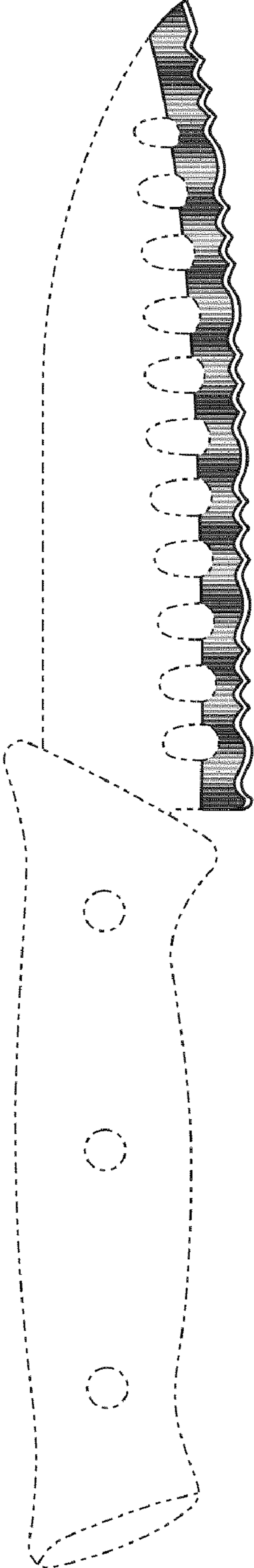

FIG. 3

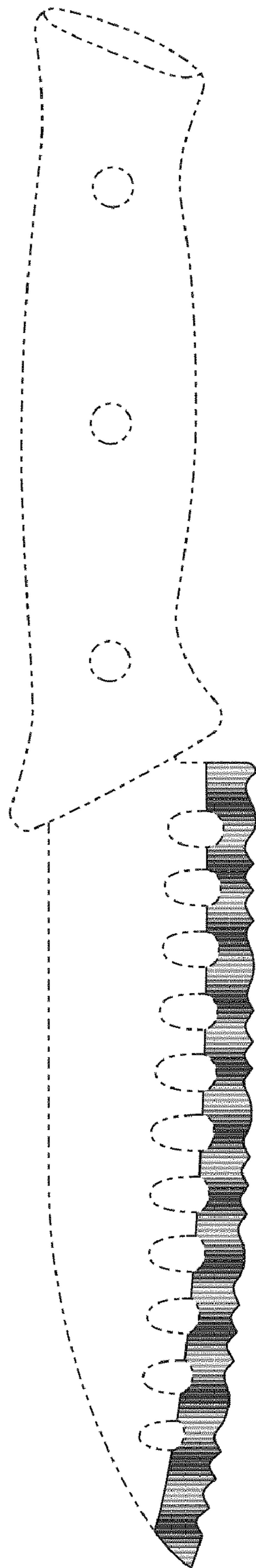

FIG. 4

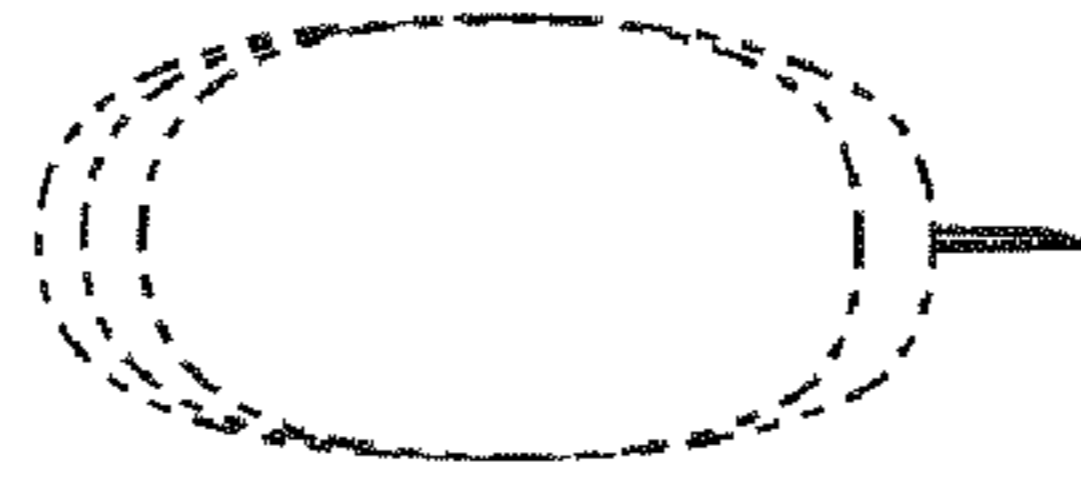

FIG. 6



FIG. 5



FIG. 7

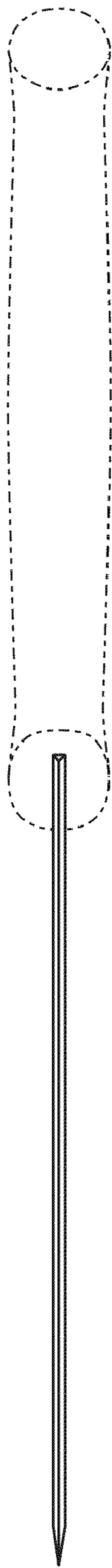

FIG. 8